

**INNOVATING
SAFETY**

since 1978

Cilindri ad azoto
Gas Springs
Gasdruckfedern
Ressorts à Gaz
Cilindros de Gas
Cilindros de Nitrogênio

2026



OUR CATALOGS



ASK FOR OR DOWNLOAD THE CATALOGS AND BROCHURES FROM OUR WEB SITE:
WWW.SPECIALSPRINGS.COM



GAS SPRINGS



**CONTROL DELAY
SYSTEMS**



**MANIFOLD
SYSTEM**



CADENAS

The updated version is always available online. Check the 'Technical Documents' section for any updates.

4	PROTECTION SAFETY	120	SC SCF	ISO 11901 Standard ISO, VDI, BMW, FCA, Ford, Mazda, MB, Nissan, VW, PSA, Renault, Suzuki
12	OPERATING INSTRUCTIONS USER INFORMATION	134	H HF	ISO, high force ISO, VDI, BMW, FCA, VW
24	BENEFITS	148	HT	For high temperature, ISO standard, high force
26	HOW TO READ THE CATALOG	156	LS	Zero force on contact
28	SELECTION TAB	166	ML	Max. force, rod seal
30	NE NG Gas Ejectors VDI, BMW, FCA, Ford, GM, VW	182	MP	Max. force, rod seal
38	M Mini Cylinders VDI, BMW, FCA, Ford, MB, PSA, VW	190	MQ	Max. force, rod seal
52	MS Mini Cylinders + SKUDO	194	KE	Max. force, piston seal
56	RV Min. height, max. force ISO, VDI, BMW, FCA, Ford, Mazda, MB, Nissan, PSA, Renault, VW	205	 Installation guideline Flange mounts	
72	RS Min. height, max. force + SKUDO	247	 Easy manifold	
86	RF Min. height, max. force FCA	260	SW Secondary rod wiper	
94	RG Min. height, max. force Nissan, Renault	262	 Linked system	
102	RT Min. height, max. force Mazda, Nissan, PSA, Renault, Toyota	316	 Accessories	
114	S ISO forces, low profile MB, Renault, Suzuki	332	EYE, CONTROL DELAY SYSTEMS, NITRO STRIP, NITROGEN PUNCHING UNIT	



SW

Raschiatore secondario
Secondary rod wiper
Zweitabstreifer
Racleur de tige secondaire
Rascador de vástago secundario
Anillo raspador secundário

More info:

p. 260



Benefits

IT

- Eccellente protezione da contaminanti liquidi e solidi.
- Poliuretano ad alte prestazioni per massima resistenza chimica ai lubrificanti.
- Aumentata durata di vita di guida e tenute dinamiche.
- Minima perdita di corsa nominale.
- Facile inserimento.
- Nessuna limitazione al libero posizionamento del cilindro.

DE

- Ausgezeichneter Schutz gegen feste und flüssige Verunreinigungen.
- Maximale chemische Beständigkeit gegen Schmierstoffe durch das Hochleistungs-Polyurethan.
- Längere Lebensdauer für Führungselemente und dynamische Dichtungen.
- Minimaler Verlust des Nennhubes.
- Einfaches Einsetzen.
- Keine Einschränkungen für die Positionierung der Gasdruckfeder.

ES

- Protección óptima contra los contaminantes líquidos y sólidos.
- Máxima resistencia química a lubricantes gracias al poliuretano de alto rendimiento.
- Mayor vida útil para elementos de guía y juntas dinámicas.
- Pérdida mínima de carrera nominal.
- Fácil de colocar.
- Ninguna limitación para el posicionamiento del cilindro.

EN

- Excellent protection from liquid and solid contaminants.
- Maximum chemical resistance to lubricants thanks to high-performance polyurethane.
- Longer lifetime for guiding elements and dynamic seals.
- Minimal loss of nominal stroke.
- Easy to insert.
- No restrictions when positioning the gas spring.

FR

- Excellente protection contre contaminants liquides et solides.
- Résistance chimique maximale aux lubrifiants grâce au polyuréthane de haute performance.
- Plus longue durée de vie pour les éléments de guidage et les joints dynamiques.
- Perte minimale de la course nominale.
- Facile à insérer.
- Pas de limitations dans le positionnement du ressort-gaz.

PT

- Excelente protecção contra contaminantes líquidos e sólidos.
- Máxima resistência química aos lubrificantes graças ao poliuretano de alto desempenho.
- Aumento do tempo de vida útil dos elementos de guia e vedações.
- Perda mínima de curso nominal.
- Fácil de inserir.
- Não há restrições ao posicionar o cilindro.



SKUDO

Protezione Attiva da Contaminanti
Active Protection from Contaminants
Aktiver Schutz vor Verunreinigungen
Protection Active contre les Contaminants
Protección Activa contra Contaminantes
Capa Protetora Contra Resíduos

Standard on: KE-RS-MS

Upon request for other models



Benefits

IT

- Elimina qualsiasi danno da contaminanti ai componenti di guida e tenuta.
- Aumenta significativamente la vita del cilindro ad azoto in presenza di contaminanti liquidi e solidi.
- Non aumenta l'altezza del cilindro ad azoto.
- È una protezione non soggetta ad usura alcuna.

DE

- Schützt vor Schäden an Führungs- und Dichtungselementen, die durch Verunreinigungen entstehen können.
- Die Lebensdauer der Gasdruckfeder bei Vorhandensein von flüssigen und festen Verunreinigungen nimmt wesentlich zu.
- Verändert die Gesamthöhe der Gasdruckfeder nicht.
- Ist ein Schutz, der nicht verschleißt.

ES

- Elimina daños de contaminantes a los componentes que garantizan la estanqueidad y guiado.
- Aumenta significativamente la vida del cilindro en presencia de contaminantes líquidos y sólidos.
- No aumenta la altura del cilindro.
- Es una protección que no sufre desgaste.

EN

- Eliminates damages to guiding and sealing components caused by contaminants.
- Significantly increases the life of gas springs used in severe working environments.
- Does not alter the height of the gas spring.
- Does not wear out.

FR

- Élimine tout endommagement du joint et des éléments de guidage du fait de contaminants.
- Augmente de manière significative la vie du ressort en présence de contaminants liquides et solides.
- Ne change pas la hauteur du ressort à gaz.
- Est une protection qui n'est pas soumise à aucune usure.

PT

- Elimina danos causados por resíduos nos anéis de vedação e guiamento.
- Aumenta significativamente a vida dos cilindros usados em ambientes de trabalho com resíduos.
- Não altera a altura do cilindro.
- É uma proteção que não desgasta.

VDI 3003

OSAS

Sicurezza Attiva Oltre Corsa
Over Stroke Active Safety
Aktive Überhubsicherung
Sécurité Active pour Surcourse
Seguridad Activa de Fin de Carrera
Segurança para Sobre Curso

VDI 3003

USAS

Sicurezza Attiva Ritorno Incontrollato
Uncontrolled Speed Active Safety
Aktiver Schutz bei unkontrolliertem Rückhub
Sécurité Active pour Retour Incontrôlé
Seguridad Activa de Retorno Incontrolado
Segurança para Retorno Descontrolado

VDI 3003

OPAS

Sicurezza Attiva Oltre Pressione
Over Pressure Active Safety
Aktive Überdruck-Sicherheitsvorrichtung
Sécurité Active Surpression
Seguridad Activa por Sobrepresión
Segurança Sobre Pressão

How it works

IT

- Scarica in modo controllato e completo la pressione interna del cilindro ad azoto quando ha subito un'oltre corsa.

EN

- Exhausts pressure in a controlled and complete manner, when the gas spring has been overstressed.

DE

- Ermöglicht das kontrollierte und komplette Entladen des Innendrucks der Gasdruckfeder bei Überhub.

FR

- Décharge la pression du ressort en mode contrôlé et complet dans le cas d'une surcourse.

ES

- Descarga la presión de manera controlada y completa en caso de que el cilindro sobrepase su carrera máxima.

PT

- Esvazia a pressão do cilindro de forma controlada e completa quando ele sofre sobre-curso.

IT

- Scarica in modo controllato e completo la pressione del cilindro ad azoto quando soggetto a ritorni incontrollati.

EN

- Exhausts pressure in a controlled and complete manner when the gas spring has been stressed by uncontrolled returns.

DE

- ermöglicht das kontrollierte und komplette Entladen des Innendrucks der Gasdruckfeder bei unkontrolliertem Rückhub.

FR

- Décharge la pression du ressort en mode contrôlé et complet dans le cas des retours non contrôlés.

ES

- Descarga la presión de manera controlada y completa en caso de que el cilindro sufra un retorno incontrolado.

PT

- Quando o cilindro sofrer retornos descontrolados, o mesmo se esvazia de uma maneira controlada e completa.

IT

- Scarica in modo controllato e completo la pressione del cilindro ad azoto quando viene superato il valore massimo consentito.

EN

- Exhausts the pressure in a controlled and complete manner when it exceeds the maximum allowed value.

DE

- kontrollierte und vollständige Entladung des Innendrucks des Zylinders bei Überschreiten des maximal zulässigen Werts.

FR

- Décharge la pression du ressort en mode contrôlé et complet lorsque la valeur maximale admissible est dépassée.

ES

- Descarga la presión de manera controlada y completa cuando se supera el valor máximo permitido.

PT

- Esvazia a pressão do cilindro de forma controlada e completa quando ele excede o valor máximo permitido.

Benefits

IT

- Riduce il rischio di danni e pericoli dovuti alla proiezione di parti in pressione.
- Si attiva automaticamente senza intervento dell'operatore.
- Non aumenta il prezzo del cilindro.

EN

- Reduces the risk of tool damage or injury due to ejection of parts under pressure.
- Self activates automatically regardless of users' intervention.
- Does not increase the price of gas springs.

DE

- Reduziert das Risiko von Schäden und Gefahren durch wegschleudernde, unter Druck stehende Teile.
- Aktiviert sich automatisch ohne Zutun des Nutzers.
- Erhöht die Kosten der Gasdruckfeder nicht.

FR

- Réduit le risque d'endommagement de l'outil ou le risque de blessure en cas d'éjection de pièces ou composants sous pression.
- S'auto-active sans intervention de l'opérateur.
- N'augmente pas le prix du ressort.

ES

- Reduce el riesgo de daños y peligros consecuencia de la proyección de partes bajo presión.
- Se activa automáticamente sin intervención del usuario.
- No aumenta el precio del cilindro.

PT

- Reduz o risco de danos para a ferramenta e ferimentos para o operador por estilhaços.
- Ativa-se automaticamente independentemente de intervenção dos usuários.
- Não aumenta o preço dos cilindros.



Over
Stroke
Active
Safety

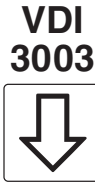

Over
Stroke
Marker

Standard on:

RV - RF - RS
RG - RT - SC
S - H - HF - HT
LS - M300

IT OSAS è un dispositivo di sicurezza costituito da un elemento posizionato alla base del corpo caratterizzato da una zona a deformazione controllata.

EN OSAS is a safety feature placed at the base of the body. It is made of a component with a controlled deformation area.

DE OSAS ist eine Sicherheitsvorrichtung, die aus einem am Boden angebrachten Element mit kontrolliert deformierbarem Bereich besteht.

FR OSAS est un dispositif de sécurité placé à la base du corps. Il est constitué d'un composant avec une zone de déformation contrôlée.

ES OSAS es un dispositivo de seguridad constituido por un elemento posicionado en la base del cuerpo y caracterizado por una zona con deformación controlada.

PT OSAS é um dispositivo de segurança localizado na base do corpo do cilindro. É um componente com uma área de deformação controlada.

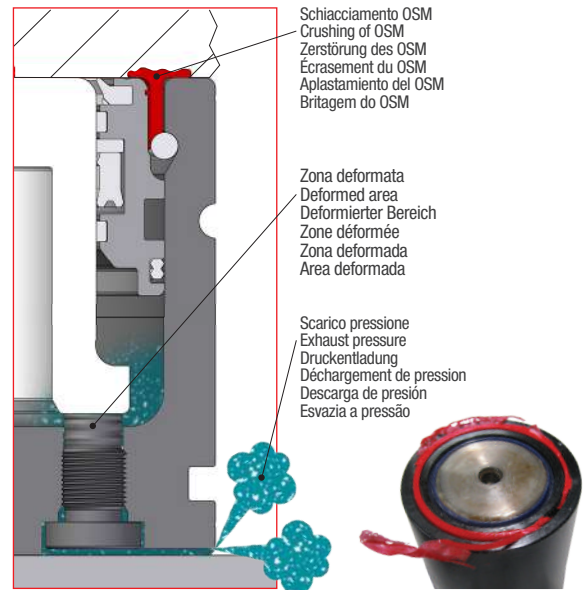
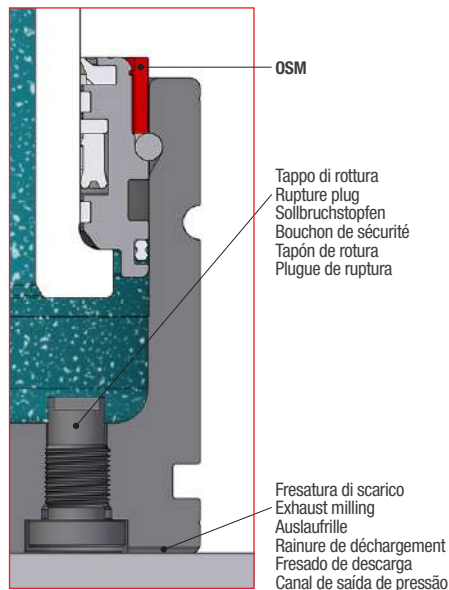

IT Il Marcatore Oltre Corsa OSM:
- permette di vedere immediatamente che il cilindro ad azoto è stato utilizzato oltre la corsa nominale massima.
- permette di intervenire tempestivamente sullo stampo eliminando la causa di oltre corsa.
- non limita il libero posizionamento del cilindro ad azoto.
- aumenta la sicurezza di utilizzo dei cilindri ad azoto Special Springs.

EN The Over Stroke Marker OSM:
- enables the user to see immediately that the gas spring has been used over its maximum nominal stroke.
- allows the user to act promptly on the die to remove the cause of the over stroke.
- doesn't restrict the free positioning of the gas spring.
- improves user safety for Special Springs' gas springs.

DE Der Überhubmarker OSM:
- ermöglicht es sofort zu sehen, dass die Gasdruckfeder über den maximalen Nennhub verwendet wurde.
- ermöglicht Ihnen, schnellstens die Ursache des Überhubs im Werkzeug zu eliminieren.
- schränkt die freie Positionierung der Gasdruckfeder nicht ein.
- verbessert die Anwendersicherheit für die Gasdruckfedern von Special Springs

FR Le Marqueur Surcourse OSM:
- vous permet de voir immédiatement que le ressort à gaz a été utilisé au-delà de la course nominale maximale.
- vous permet d'agir rapidement sur le moule afin d'éliminer la cause de la surcourse.
- ne limite pas un positionnement libre du ressort à gaz.
- améliore la sécurité des utilisateurs des ressorts à gaz Special Springs.

ES El Marcador de Sobrecarrera OSM:
- permite ver inmediatamente que el cilindro ha sido utilizado por encima de la carrera nominal máxima.
- permite actuar con rapidez en el troquel para eliminar la causa de la sobrecarrera.
- no limita el posicionamiento libre del cilindro.
- aumenta la seguridad del usuario de los cilindros de nitrógeno Special Springs.

PT O Marcador do Sobre Curso OSM:
- permite verificar imediatamente que o curso de trabalho esta excedendo o curso nominal máximo do cilindro.
- permite ação rápida na ferramenta para solucionar o problema.
- não limita o posicionamento livre do cilindro.
- aumenta a segurança do utilizador dos cilindros Special Springs.



Over
Stroke
Active
Safety

VDI
3003



Standard on: ML - MP - MQ

IT OSAS è la combinazione di una zona deformabile del corpo e delle gole di scarico presenti sulla superficie interna del corpo.

EN OSAS is the combination of a deformable body skirt and of the exhaust grooves on the internal body surface.

DE OSAS ist die Kombination einer deformierbaren Zone des Körpers und der Auslaufrillen an der Innenoberfläche des Körpers.

FR OSAS est la combinaison d'une zone déformable du corps et des rainures de déchargement sur la surface interne du corps.

ES OSAS es la combinación de una zona deformable del cuerpo y de las ranuras de descarga en la superficie interna del cuerpo.

PT OSAS é a combinação de uma área do corpo deformável e das ranhuras de saída de pressão na superfície interna do corpo.

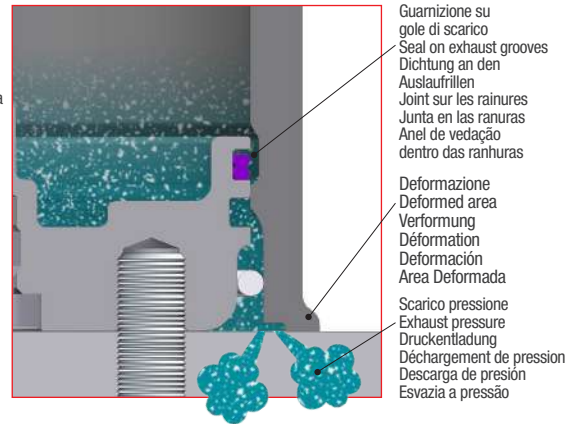
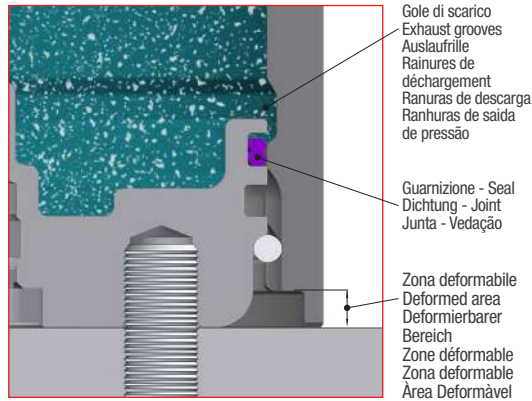

Standard on: KE

IT OSAS è realizzata con delle gole di scarico presenti sulla superficie interna del corpo.

EN OSAS consists in the presence of exhaust grooves on the internal body surface.

DE OSAS besteht aus Auslaufrillen an der Innenoberfläche des Körpers.

FR OSAS est constitué par des rainures de déchargement sur la surface interne du corps.

ES OSAS consiste en ranuras de descarga en la superficie interna del cuerpo.

PT OSAS é ativado com ranhuras de saída de pressão na superfície interna do corpo.

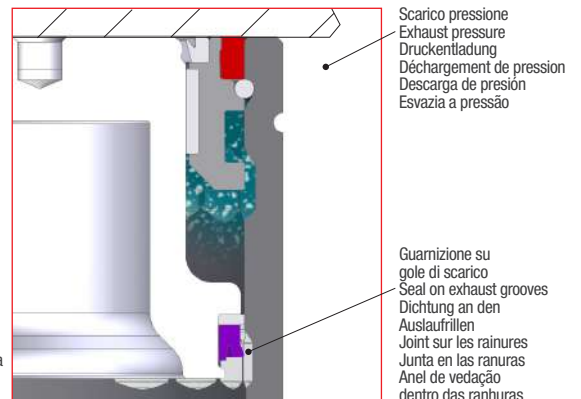
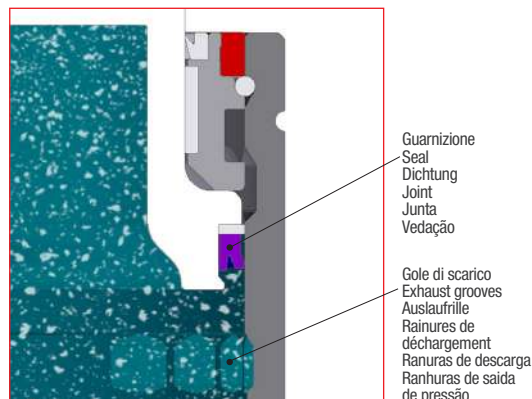



Uncontrolled
Speed
Active
Safety

VDI
3003



Standard on:
RV - RF - RS
RG - RT - SC
S - H - HF - HT
LS - M300

IT USAS è la combinazione di una zona deformabile della boccia e delle gole di scarico presenti sulla superficie interna del corpo.

EN USAS is the combination of a deformable area of the bushing and the exhaust grooves on the internal body surface.

DE USAS besteht aus der Kombination eines verformbaren Bereichs der Buchse und den Auslaufrillen an der Innenoberfläche des Körpers.

FR USAS est la combinaison d'une zone déformable de la douille et des rainures de déchargement sur la surface interne du corps.

ES USAS es la combinación de una zona deformable del casquillo y de las ranuras de descarga en la superficie interna del cuerpo.

PT USAS é a combinação de uma parte deformável da bucha e as ranhuras de saída de pressão na superfície interna do corpo.

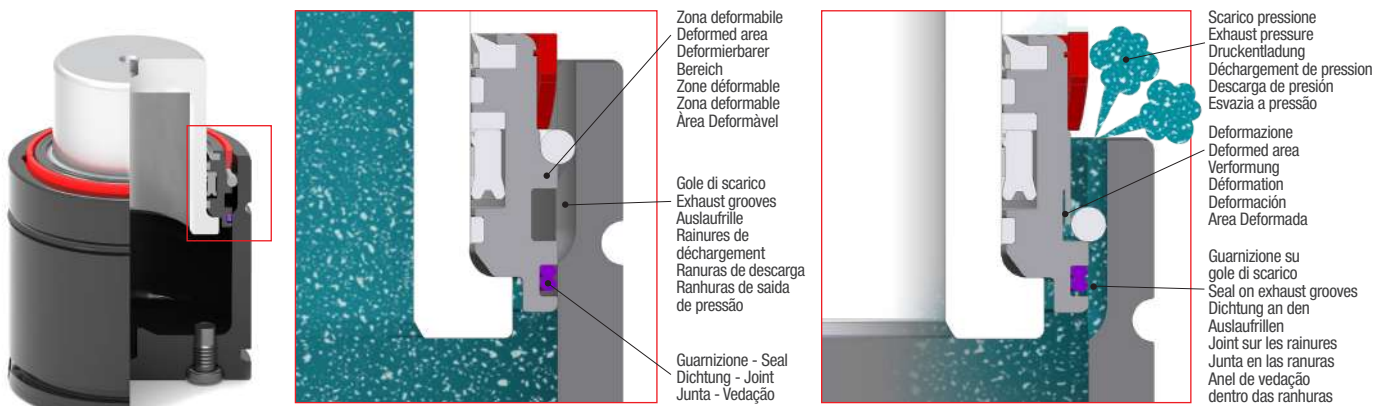

Standard on: ML - MP - MQ

IT USAS è la combinazione di una zona deformabile del fondello e delle gole di scarico presenti sulla superficie interna del corpo.

EN USAS is the combination of a deformable area of the bottom base and the exhaust grooves on the internal body surface.

DE USAS ist die Kombination eines deformierbaren Bereichs am Boden und den Auslaufrillen an der Innenoberfläche des Körpers.

FR USAS est la combinaison d'une zone déformable de la plaque inférieure et des rainures de déchargement sur la surface interne du corps.

ES USAS es la combinación de una zona deformable de la placa inferior y de las ranuras de descarga en la superficie interna del cuerpo.

PT USAS é a combinação de uma area deformável da placa base e das ranhuras de saída de pressão na superfície interna do corpo.

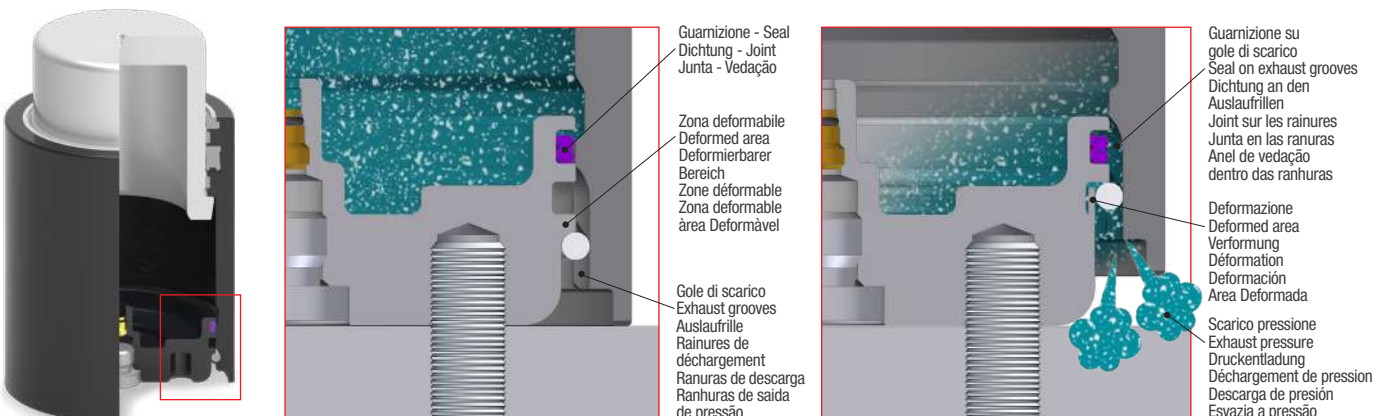

Standard on: KE

IT USAS è la combinazione di una zona deformabile della boccola e delle gole di scarico presenti sulla superficie interna del corpo.

EN USAS is the combination of a deformable area of the bushing and the exhaust grooves on the internal body surface.

DE USAS besteht aus der Kombination eines verformbaren Bereichs der Buchse und den Auslaufrillen an der Innenoberfläche des Körpers.

FR USAS est la combinaison d'une zone déformable de la douille et des rainures de déchargement sur la surface interne du corps.

ES USAS es la combinación de una zona deformable del casquillo y de las ranuras de descarga en la superficie interna del cuerpo.

PT USAS é a combinação de uma parte deformável da bucha e as ranhuras de saída de pressão na superfície interna do corpo.

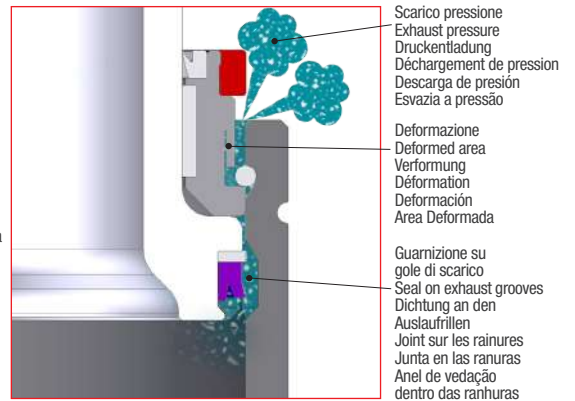
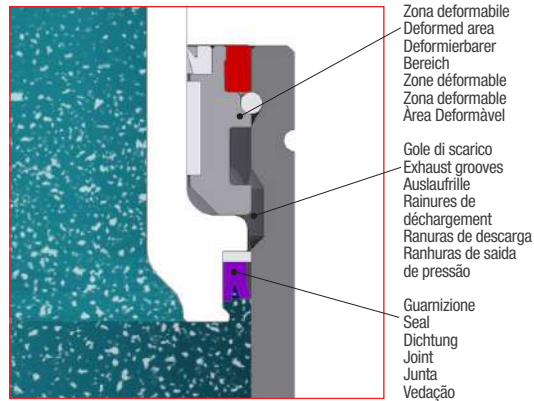

Over
Pressure
Active
Safety



VDI
3003

Standard on:
M - MS - RV - RS
RF - RG - RT - S
SC - H - HF - HT
LS - ML - MP - KE

IT OPAS è la combinazione di un tappo di rottura (o di un setto di rottura calibrato) con una fresatura di scarico sulla base di appoggio del cilindro ad azoto.

EN OPAS is the combination of a rupture plug (or a calibrated rupture septum) with an exhaust milling on the bottom contact surface of the gas spring.

DE OPAS ist die Kombination aus einem kalibrierten Sollbruchstopfen (oder Sollbruchstelle) mit einer Auslaufrille an der unteren Auflagefläche der Gasdruckfeder.

FR OPAS est la combinaison d'un bouchon de sécurité (ou d'une zone fusible) avec un fraisage de déchargement sur la surface inférieure du ressort gaz.

ES OPAS es la combinación de un tapón de rotura (o de un septo de rotura) con un fresado de descarga posicionados en la base de apoyo del cilindro.

PT OPAS é a combinação de um plugue de ruptura (ou um septo de ruptura) com um canal usinado na parte inferior do cilindro.

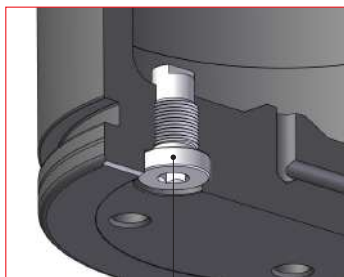

Tappo di rottura - Rupture plug - Sollbruchstopfen
Bouchon de sécurité - Tapón de rotura - Plugue de ruptura

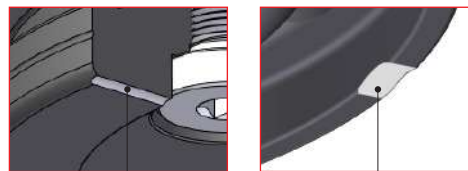

Fresatura di scarico - Exhaust milling - Auslaufrille
Fraisage de déchargement - Fresado de descarga - Canal de saída de pressão

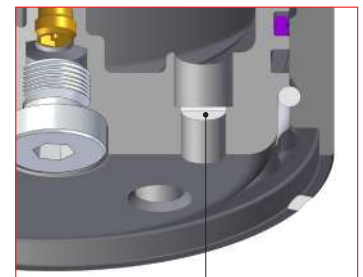

Setto di rottura - Rupture septum - Sollbruchstelle
Zone fusible - Septo de rotura - Septo de ruptura

Se si sono attivate le sicurezze, verificare e scaricare eventuali residui di pressione, eliminare le cause del danno e sostituire sempre il cilindro ad azoto danneggiato.

If the safety features are activated, verify and exhaust the possible pressure leftovers, remove the causes of the damage and replace always the damaged gas spring.

Wenn die Sicherungen aktiviert werden, prüfen und entladen Sie eventuellen Restdruck, beseitigen Sie die Ursachen des Schadens und ersetzen Sie immer die beschädigte Gasdruckfeder.

Quand les sécurités sont activées, vérifier et décharger les éventuels résidus de pression, éliminer les causes de l'endommagement et toujours remplacer les ressorts gaz endommagés.

Si se activan los dispositivos de seguridad, verificar y descargar toda la presión residual, eliminar las causas de los daños y reemplazar siempre el cilindro dañado.

Se os dispositivos de segurança são ativados, verificar e descarregar qualquer pressão residual, eliminar as causas dos danos e substituir sempre o cilindro danificado.



1381



PED 2014/68/EU

IT

- La progettazione e la produzione dei cilindri ad azoto Special Springs sono realizzate nel pieno rispetto delle normative vigenti per i recipienti in pressione come stabilito dalla direttiva PED 2014/68/EU e EN 13445:2015.

EN

- The design and manufacturing of Special Springs gas springs are in full compliance with the European regulations for high pressure vessels, in accordance with directive PED 2014/68/EU and EN 13445:2015.

DE

- Die Konstruktion und Herstellung der Special Springs Gasdruckfedern erfolgt in Übereinstimmung mit den geltenden Normen für Druckbehälter, wie in der PED Richtlinie 2014/68/EU und EN 13445:2015 festgelegt.

FR

- La conception et la fabrication des ressorts à gaz Special Springs sont en totale conformité avec les législations Européennes en matière de composants caractérisés haute pression et notamment avec la directive PED 2014/68/EU et EN 13445:2015.

ES

- La proyectación y producción de los cilindros de nitrógeno Special Springs se realizan con pleno respeto de las normativas vigentes para elementos de presión como establece la directiva PED 2014/68/EU y EN 13445:2015).

PT

- O projeto e fabricação de cilindros de Nitrogênio Special Springs estão em total conformidade com as regras Europeias para Cilindros de alta pressão, em conformidade com a directiva PED 2014/68/EU e EN 13445:2015.

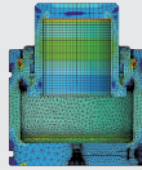

FEM - CAE

IT

- Tutti i prodotti Special Springs sono sviluppati e validati con l'utilizzo dei più avanzati sistemi di analisi FEM (finite element method) e CAE (computer aided engineering).

EN

- All Special Springs products are developed and validated via the use of the most advanced FEM (finite element method) and CAE (computer aided engineering) analysis systems.

DE

- Alle Produkte von Special Springs werden durch die Verwendung der fortschrittlichsten Analysensysteme FEM (finite element method) und CAE (computer aided engineering) entwickelt und validiert.

FR

- Tous les produits Special Springs sont développés et certifiés selon les méthodes FEM (finite element method) et CAE (Computer aided engineering).

ES

- Todos los productos Special Springs son desarrollados y validados con la utilización de los más avanzados sistemas de análisis FEM (finite element method) y CAE (computer aided engineering).

PT

- Todos os produtos Special Springs são desenvolvidos e validados através da utilização das Técnicas mais avançadas FEM (método de elementos finitos) e sistemas de análise do CAE (Engenharia assistida por computador).

> 2.000.000

STRUCTURE OF THE GAS SPRING

IT

- Tutti i componenti strutturali dei cilindri ad azoto Special Springs sono progettati e costruiti per sopportare minimo 2.000.000 di cicli completi alla massima pressione, temperatura e per ogni tipo di fissaggio.

EN

- All structural components of Special Springs gas springs are designed and built to withstand a minimum of 2,000,000 complete cycles at maximum pressure, temperature and for all types of fixings.

DE

- Alle Strukturkomponenten der Special Springs Gasdruckfedern sind so konzipiert und hergestellt, um mindestens 2.000.000 komplette Zyklen bei maximalem Druck und Temperatur und für jede Befestigungsart zu erreichen.

FR

- Tous les composants structuraux des ressorts gaz Special Springs sont conçus et construits pour supporter un minimum de 2 million des cycles complètes à la pression et température maximale pour chaque type de fixation.

ES

- Todos los componentes estructurales de los cilindros de gas Special Springs están diseñados y fabricados para soportar un mínimo de 2.000.000 de golpes completos a la máxima presión, temperatura y para cualquier tipo de fijación.

PT

- Todos os componentes estruturais dos cilindros Special Springs, são projetados e construídos para suportar no mínimo 2.000.000 ciclos com máxima pressão, temperatura e para todos os tipos de dispositivos de fixação.

Benefits

IT

- Maggiore garanzia di prodotti e componenti sicuri per il cliente.

EN

- Greater assurance of safe products and components for customers.

DE

- verbesserte Sicherheit für den Kunden durch sichere Produkte und Komponenten.

FR

- Plus grande assurance de produits et composants sûrs pour les clients.

ES

- Mayor garantía de productos y componentes seguros para los clientes.

PT

- Maior garantia de produtos e componentes seguros para os clientes.



KNOWLEDGE

IT

- La conoscenza è un elemento fondamentale per azioni quotidiane di successo, più conosciamo meglio facciamo. Questo concetto è da sempre presente nella filosofia del lavoro di Special Springs. Da molti anni Special Springs è impegnata per aumentare la conoscenza dei prodotti e delle loro caratteristiche unitamente alle migliori tecniche di utilizzo attraverso formazioni teoriche e pratiche.

EN

- Knowledge is an essential element for successful daily actions; the more we know, the better we perform. This concept has always been one of Special Springs' core values. For many years the company has committed to increase knowledge of products along with their characteristics and their best utilisations techniques, through theoretical and practical training.

DE

Fachkenntnis ist ein grundlegendes Element für tägliche, erfolgreiche Tätigkeiteng, je mehr wir wissen, desto besser können wir handeln. Dieses Konzept ist schon immer die Arbeitsphilosophie von Special Springs. Seit vielen Jahren ist Special Springs bestrebt, die Fachkenntnisse rund um die Produkte und ihre technischen Eigenschaften zusammen mit den neuesten Anwendungstechniken zu perfektionieren und durch theoretische und praktische Schulungen zu vertiefen.

FR

- La connaissance est un élément fondamental pour les actions quotidiennes de succès, mieux on connaît, mieux on fait. Ce concept a été toujours présent dans la philosophie de travail de Special Springs. Depuis plusieurs années Special Springs s'est engagé à augmenter la connaissance des produits et de ses caractéristiques mais aussi aux meilleures techniques d'usage à travers formations théoriques et pratiques.

ES

- El conocimiento es un elemento fundamental para acciones cotidianas que lleven al éxito, cuanto más se conoce mejor se hace. Este concepto ha estado siempre en la filosofía de trabajo de Special Springs. Special Springs se dedica desde hace muchos años a aumentar su conocimiento sobre los productos y sus características, así como a mejorar las técnicas de uso a través de formaciones teóricas y prácticas.

PT

- O conhecimento é um elemento essencial para o sucesso das ações diárias; Quanto mais soubermos, melhor nós executamos. Este conceito sempre foi um dos valores da Special Springs. Por muitos anos a empresa se comprometeu a aumentar os conhecimentos dos produtos juntamente com suas características e suas melhores técnicas de utilizações através de formação teórica e prática.



TECHNICAL SUPPORT

IT

- Special Springs, da sempre impegnata per migliorare il supporto tecnico agli utilizzatori, fornisce con ogni cilindro o suo componente un completo foglio di istruzioni multilingua.

EN

- Special Springs has always been committed to provide technical support for users; we provide a thorough multilingual instruction sheet with each gas spring or component.

DE

- Special Springs ist schon immer bestrebt, den technischen Support der Anwender zu verbessern, für jede Gasdruckfeder und deren Komponenten ist eine mehrsprachige Betriebsanleitung verfügbar.

FR

- Special Springs s'est engagée depuis longtemps pour améliorer le support technique aux utilisateurs, elle fournit avec chaque ressort ou composant un papier d'instruction multilingue complet.

ES

- Es prioridad desde siempre para Special Springs la mejora del soporte técnico al usuario, para lo que entrega un manual completo en varios idiomas con cada cilindro o componente.

PT

- A Special Springs é empenhada em fornecer suporte técnico para usuários; Nós fornecemos uma folha de instruções multilingue completa com cada cilindro ou componente.

Benefits

IT

- Maggiore conoscenza degli utilizzatori sui reali vantaggi offerti dai cilindri ad azoto Special Springs.
- Maggiore conoscenza degli utilizzatori sui più corretti metodi di utilizzo con vantaggi economici e di sicurezza.
- Maggiore sensibilità e coscienza sull'importanza delle sicurezze attive sui cilindri ad azoto.

EN

- Increased knowledge of users, in regards to the real benefits given by Special Springs gas springs.
- Increased knowledge of users on how to appropriately use the products, hence benefit from cost and production efficiency.
- Increased knowledge of users on the importance of our gas springs safety features.

DE

- größeres Wissen der Anwender über die effektiven Vorteile der Special Springs Gasdruckfedern.
- größeres Wissen der Anwender über die am besten geeigneten Anwendungsverfahren mit wirtschaftlichen und sicherheitsrelevanten Vorteilen.
- besseres Verständnis bzw. Bewusstsein der Wichtigkeit der aktiven Sicherheitselemente an Gasdruckfedern.

FR

- Majeure connaissance des utilisateurs sur les avantages réels offert par les ressorts à gaz Special Springs.
- Majeure connaissance des utilisateurs sur les méthodes de usage plus correctes avec avantages économiques et de sécurité.
- Majeure sensibilité et conscience sur l'importance des sécurités actives dans les ressorts à gaz.

ES

- Mayor conocimiento por parte del usuario de las ventajas ofrecidas por los cilindros Special Springs.
- Mayor conocimiento por parte del usuario de los métodos correctos para aumentar la seguridad de uso.
- Mayor sensibilidad y conciencia de la importancia de la seguridad activa en los cilindros de nitrógeno.

PT

- Aumento do conhecimento dos usuários, no que diz respeito aos benefícios reais dados pelo Cilindro de Nitrogênio Special Springs.
- Aumento do conhecimento dos usuários sobre como usar adequadamente os produtos, portanto, aumentando a eficiência de custo e produção.
- Aumento do conhecimento dos usuários sobre a importância de nossas características de segurança do cilindros de Nitrogênio.

OPERATING INSTRUCTIONS



- IT** Caricare soltanto con GAS AZOTO (N2).
- EN** Charge only with NITROGEN GAS (N2).
- DE** Gasdruckfedern dürfen nur mit STICKSTOFF GAS (N2) gefüllt werden.
- FR** Charge seulement avec du GAZ AZOTE (N2).
- ES** Cargar únicamente con GAS NITRÓGENO (N2).
- PT** Carregar somente com GÁS de NITROGÊNIO (N2).

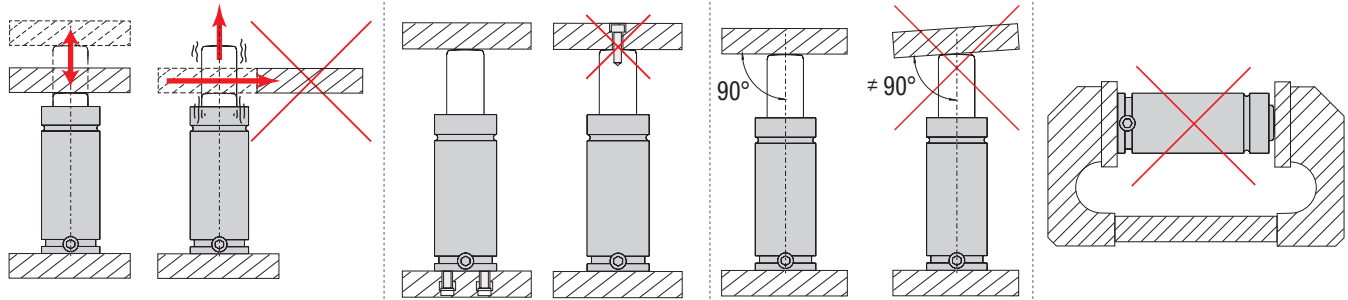

IT Tutti i cilindri Special Springs sono dotati di riserva corsa da 1 a 3 mm (escluso M90/TBM-TBI-TEM). Quindi il valore nominale Cu è completamente utilizzabile. Si raccomanda comunque di prevedere una riserva corsa aggiuntiva pari al 10% della corsa nominale o 5mm per corse superiori a 50mm per prevenire eventuali extra-corse che potrebbero verificarsi, e causare danni irreparabili ai cilindri e gravi rischi per la sicurezza.

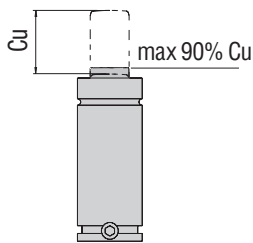

EN All Special Springs gas springs are designed with a stroke reserve from 1 to 3 mm (except M90/TBM-TBI-TEM). Thus, the nominal value Cu is fully applicable. However, it is recommended to keep a stroke reserve of 10% of the nominal stroke or 5 mm for strokes longer than 50 mm, in order to avoid the risk of any over stroke possibly causing damages to things and/or injury to people.

DE Alle Gasdruckfedern von Special Springs verfügen über eine Hubreserve von 1 bis 3 mm (Ausnahme M90/TBM-TBI-TEM). Daher kann der Nennwert Cu 100% verwendet werden. Es wird jedoch empfohlen, eine zusätzliche Hubreserve von 10% des Nennhubs bzw. 5 mm bei Hüben über 50 mm einzuhalten, um die Gefahr eines Überhubs zu vermeiden, die mögliche irreparable Beschädigungen- und/oder Personenschäden verursachen können.

FR Tous les ressorts gaz Special Springs sont conçus avec une réserve de course de 1 à 3 mm (sauf M90/TBM-TBI-TEM). Ainsi, la valeur nominale Cu est pleinement applicable. Cependant, il est recommandé de conserver une réserve de course de 10% de la course nominale ou de 5 mm pour les courses supérieures à 50 mm, afin d'éviter le risque d'une éventuelle course supplémentaire qui pourrait causer des dommages matériels et/ou corporels.

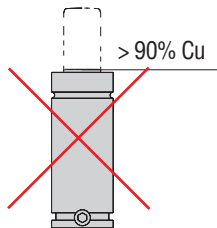

ES Todos los cilindros de gas SPECIAL SPRINGS están dotados de una reserva de carrera de 1 a 3 mm (excepto M90 / TBM-TBI-TEM). Por lo tanto el valor nominal Cu es completamente utilizable. De todos modos, se recomienda proporcionar una reserva de carrera adicional igual al 10% de la carrera nominal o 5 mm para carreras superiores a 50 mm para evitar cualquier sobre carrera que pudiera causar daños a cosas y/o lesiones a personas.

PT Todos os cilindros da Special Springs são projetados com uma reserva de curso de 1 a 3mm (exceto os modelos M90/TBM-TBI-TEM). O que permite a utilização de 100% do curso nominal do cilindro. No entanto, recomenda-se manter uma reserva de 10% do curso nominal ou 5mm para cilindros com curso superior a 50mm, para evitar o risco de sobre curso, que possa causar danos aos cilindros ou até pessoas.

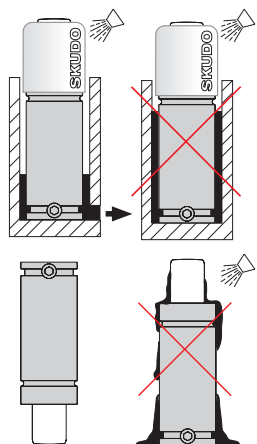

IT In presenza di contaminanti liquidi o solidi utilizzare cilindri con SKUDO. In mancanza di cilindri con SKUDO, un miglioramento significativo si ottiene installando i cilindri capovolti.

EN In presence of liquid or solid contaminants, use gas springs with SKUDO. In absence of gas springs with SKUDO protection, a significant improvement could be obtained by mounting the gas springs in upside-down position.

DE Verwenden Sie in Bereichen, in denen die Gasdruckfeder dem Einwirken von Flüssigkeiten oder Schmutzpartikeln ausgesetzt ist, Gasdruckfedern mit SKUDO. Wenn SKUDO nicht eingesetzt werden kann, empfehlen wir, die Gasdruckfeder mit nach unten stehendem Kolben zu montieren, um das Eindringen der Flüssigkeit oder der Schmutzpartikel in die Gasdruckfeder zu vermeiden.

FR En presence de contaminants liquides ou solides, utiliser les ressorts avec SKUDO. En absence de ressorts avec SKUDO, une amélioration importante peut s'obtenir en montant les cylindres renversés.

ES En presencia de contaminantes líquidos o sólidos, se recomienda el uso de cilindros con SKUDO. A falta de cilindros con SKUDO, una notable mejora se obtiene montando los cilindros boca abajo.

PT Procurar sempre utilizar cilindros com Skudo quando o mesmo for trabalhar em contato com elementos contaminantes líquidos ou sólidos. Quando não for possível a utilização dos cilindros com o Skudo, tentar fixar os cilindros de cabeça para baixo.

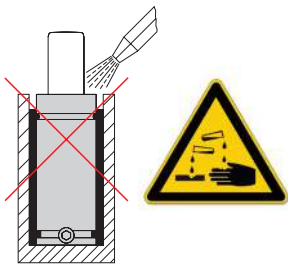

IT Evitare il contatto di fluidi aggressivi (soda e cloruri) con i cilindri. Se utilizzati per la pulizia dello stampo, si raccomanda di rimuovere dai cilindri ogni residuo.

EN Avoid any contact of gas springs with aggressive fluids (soda or chlorites). If they are used for cleaning the tools, we recommend to carefully remove any residue from gas springs.

DE Werden aggressive Flüssigkeiten (Soda oder Chloride) zur Reinigung des Bauteils verwendet, dürfen diese nicht mit den Gasdruckfedern in Kontakt kommen bzw. jeglicher Rückstand davon muss von den Gasdruckfedern entfernt werden.

FR Éviter le contact des liquides agressifs (soda ou chlorites) avec les cylindres. S'ils sont utilisés pour le nettoyage des moules, il est recommandé d'enlever tous résidus sur les cylindres.

ES Evite el contacto de fluidos agresivos (soda o cloruro) con los cilindros. Si se utilizan para la limpieza de herramientas, recomendamos eliminar cualquier residuo de los cilindros.

PT Evitar qualquer contato dos cilindros com fluidos agressivos (soda ou cloretos). Se forem usados para limpar ferramentas, recomendamos remover todos os resíduos dos cilindros.

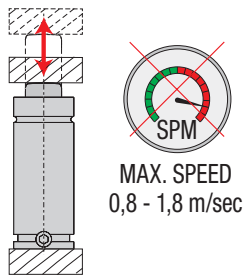

IT Non confondere la velocità massima con il numero massimo di cicli al minuto, come raccomandato per ogni modello.

EN Do not confuse the maximum speed with the maximum number of strokes per minute, as recommended for each model.

DE Die maximale Geschwindigkeit darf nicht mit der maximalen Hubzahl pro Minute verwechselt werden, wie dies für jedes Modell empfohlen wird.

FR Ne confondez pas la vitesse maximale avec le nombre maximal de coups par minute, comme recommandé pour chaque modèle.

ES No debe confundirse la velocidad máxima con el número máximo de golpes por minuto, tal como se recomienda para cada modelo.

PT Não confunda a velocidade máxima com o número máximo de golpes por minuto, conforme o recomendado para cada modelo.

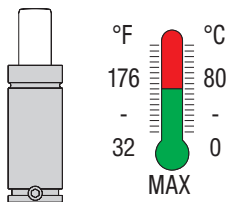

IT Temperatura di funzionamento.

EN Operating temperature.

DE Arbeitstemperatur.

FR Température de fonctionnement.

ES Temperatura de funcionamiento.

PT Temperatura de operação.

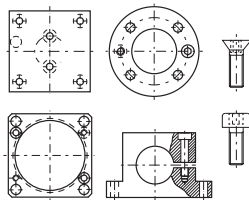

IT Si raccomanda di installare sempre i cilindri con gli appositi elementi di fissaggio.

EN It is always recommended to install the gas springs with the suitable fixing elements.

DE Es wird immer empfohlen, die Gasdruckfedern mit den geeigneten Befestigungselementen zu fixieren.

FR Il est toujours recommandé de fixer les cylindres avec les éléments de fixation appropriés.

ES Se recomienda fijar siempre los cilindros con los elementos de fijación apropiados.

PT É aconselhável fixar sempre os cilindros com os elementos de fixação adequados.

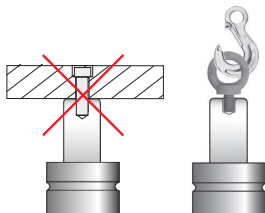

IT Utilizzare il foro filettato sullo stelo solo per la movimentazione dei cilindri.

EN Use the threaded hole on the rod only for gas springs' handling.

DE Die Gewindebohrung an der Kolbenstange ist ausschließlich für die Bewegung der Gasdruckfedern zu verwenden.

FR Utiliser le trou fileté sur la tige uniquement pour la manipulation des cylindres.

ES Utilizar el orificio roscado en el vástago solo para la manipulación de los cilindros.

PT Utilizar o furo roscado na haste só para o manuseio dos cilindros.

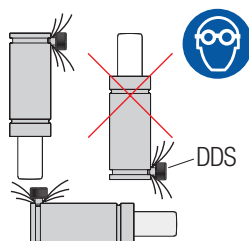

IT Durante lo scaricamento con l'uso del dispositivo DDS, orientare il flusso del gas in direzione opposta all'operatore.

EN When discharging by using a DDS device, direct the gas flow away from operator.

DE Während der Entladung mit Hilfe der DDS-Vorrichtung, richten Sie den Gasfluss in die dem Bediener entgegengesetzte Richtung.

FR Pendant le déchargement à l'aide du dispositif DDS, orientez le flux du gaz dans la direction opposée à l'opérateur.

ES Durante la descarga mediante el dispositivo DDS, orientar el flujo del gas en dirección contraria al operador.

PT Durante a descarga com a utilização do dispositivo DDS, orientar o fluxo de gás na direção oposta à do operador.

OPERATING INSTRUCTIONS

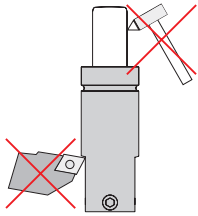

- IT** Evitare qualsiasi lavorazione meccanica o impatto su corpo e stelo.
- EN** Avoid any mechanical tooling or impact on the body and the rod.
- DE** Vermeiden Sie mechanische Bearbeitungen jeder Art oder sonstige Einwirkungen auf Körper und Kolbenstange.
- FR** Éviter toute opération mécanique ou impact sur le corps et la tige.
- ES** Evitar cualquier clase de elaboración mecánica o impacto contra cuerpo y vástago del cilindro.
- PT** Evitar qualquer trabalho mecânico ou impacto sobre o corpo e haste.



- IT** Se un cilindro ha la struttura danneggiata, prima di qualsiasi manipolazione, scaricare completamente la pressione.
- EN** If a gas spring has structural damage, fully exhaust all pressure before any form of handling.
- DE** Weist die Gasdruckfeder Beschädigungen auf, muss vor dem Eingriff der Druck vollständig abgelassen werden.
- FR** Si la structure d'un cylindre est endommagée, décharger complètement la pression, avant d'effectuer toute opération.
- ES** Si un cilindro presenta desperfectos en su estructura, descargar completamente la presión antes de proceder a revisarlo.
- PT** Se um cilindro tiver a estrutura danificada, antes de qualquer manipulação, descarregar completamente a pressão.

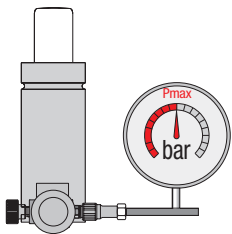

- IT** Durante il caricamento non eccedere la pressione massima raccomandata per ogni modello.
- EN** When charging do NOT exceed the maximum recommended pressure for each model.
- DE** Überschreiten Sie während der Ladung den für jedes Modell angegebenen Druckwert nicht.
- FR** Durant le chargement, il est conseillé de ne pas dépasser la pression maximum recommandée pour chaque modèle.
- ES** Durante la carga, no superar nunca la presión máxima aconsejada para cada modelo.
- PT** Durante a carga, não exceder a pressão máxima recomendada para cada modelo.

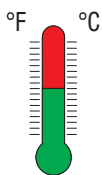

± 1 °C = ?



$$\Delta P = P_0 \times 0.33\% \times \Delta T$$

- IT** Ogni variazione della temperatura rispetto al valore nominale di calcolo di 20°C determina una variazione della pressione del gas (P).
- EN** Any variation in temperature, respect to the nominal calculation value of 20°C, causes a change in gas pressure (P).
- DE** Jede Temperatur, die vom berechneten Nennwert (20°C) abweicht, bewirkt eine Änderung des Gasdrucks (P).
- FR** Chaque modification de la température, par rapport à la valeur nominale de calcul de 20°C, détermine une modification de la pression du gaz (P).
- ES** Toda variación de temperatura con respecto al valor nominal de cálculo de 20°C, determina una variación de la presión del gas (P).
- PT** Qualquer variação da temperatura, no que respeita ao valor nominal de cálculo de 20°C, determina uma variação da pressão do gás (P).

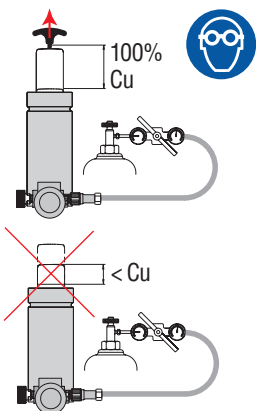

- IT** Durante il caricamento assicurarsi che lo stelo sia estratto al 100%. Per cilindri privi di foro filettato sullo stelo, caricare inizialmente con 5 bar (75 psi) per estrarre completamente lo stelo, quindi procedere fino alla pressione desiderata.
- EN** Ensure that the rod is 100% extracted when charging. For gas springs without a threaded hole on the rod, initially charge to 5 bar (75 psi) to extract the rod completely, then charge to the required pressure.
- DE** Stellen Sie vor der Befüllung der Gasdruckfeder sicher, dass die Kolbenstange ganz ausgefahren ist. Befüllen Sie Gasdruckfedern ohne Gewinde am Ende der Kolbenstange anfangs nur mit 5 bar (75 psi), um die Kolbenstange vollständig in die ausgefahrene Position zu drücken. Steigern Sie anschließend den Befülldruck auf den gewünschten Wert.
- FR** Durant le chargement, s'assurer que la tige soit complètement sortie. Les cylindres sans trou fileté sur la tige doivent être chargés initialement avec 5 bars (75 psi) pour extraire complètement la tige; procéder ensuite jusqu'à la pression désirée.
- ES** Durante la carga, asegurarse de que el vástago esté extraído al 100%. En cilindros con vástago sin orificio roscado, comenzar con una carga de 5 bar (75 psi) al fin de extraer completamente el vástago. Sólo entonces proseguir cargando hasta alcanzar la presión deseada.
- PT** Durante a carga, assegure-se de que o haste esteja totalmente extraído. Para cilindros sem orifício roscado no haste, carregar inicialmente com 5 bar (75 psi) para extrair completamente haste, depois, proceder até à pressão desejada.



- IT** Prima di gettare i cilindri ad azoto scaricare completamente la pressione.
- EN** Before disposing a gas spring ensure that all residual pressure is fully exhausted.
- DE** Vor der Entsorgung muss jede Gasdruckfeder vollständig vom Druck entleert werden.
- FR** Décharger complètement la pression, avant de jeter tout cylindre à gaz.
- ES** Nunca tirar un cilindro de gas sin antes haber descargado por completo la presión.
- PT** Antes de deitar fora qualquer cilindro a gás, descarregar completamente a pressão.



IT Tutti i cilindri collegabili a sistema e specificatamente codificati sono forniti senza valvola unidirezionale, senza pressione e con il solo tappo di chiusura del foro di collegamento (escluso M90, M200, RV170, RV320). Nel caso si desideri trasformare dei cilindri autonomi in cilindri collegabili a sistema è sufficiente ordinare i raccordi e i tubi necessari e seguire le istruzioni specifiche per ogni serie pubblicate nel sito www.specialsprings.com.

EN All gas springs which can be connected to the system and are specifically coded are supplied without the one-way valve, without pressure and with only the closure plug of the connection hole (excluding M90, M200, RV170, RV320). If you wish to convert independent gas springs into system-connectable gas springs, order the necessary hoses and connections, and follow the specific instructions for every series published on site www.specialsprings.com.

DE Alle Gasdruckfedern, die in ein Verbundsystem integrierbar sind und mit entsprechenden Zusatzangaben bestellt werden, werden ohne Rückschlagventil, unbefüllt und nur mit der in der Anschlussöffnung montierten Verschlusschraube geliefert (Ausnahmen: M90, M200, RV170, RV320). Sollen eigenständig arbeitende Gasdruckfedern für die Nutzung in einem Verbundsystem umgebaut werden, genügt es, die erforderlichen Anschlüsse und Leitungen zu bestellen, sowie die für die jeweilige Serie auf der Internetseite www.specialsprings.com veröffentlichten Hinweise zu beachten.

FR Tous les cylindres qui peuvent être raccordés au système et qui possèdent un code d'identification spécifique sont fournis sans valve unidirectionnelle ni pression. Seul le bouchon de fermeture de l'orifice de raccordement est fourni (sauf M90, M200, RV170, RV320). Au cas où l'on souhaiterait transformer des cylindres autonomes en cylindres à système raccordables, il suffira de commander les raccords et les tubes nécessaires puis de suivre les instructions spécifiques de chaque série, publiées sur le site www.specialsprings.com.

ES Todos los cilindros que se pueden conectar entre sí, que tienen códigos específicos, se suministran sin válvula unidireccional y sin presión, solo con el tapón de cierre del orificio de conexión (menos M90, M200, RV170, RV320). Si se desea transformar cilindros autónomos en cilindros conectables, basta con pedir los elementos de conexión y mangueras necesarios y seguir las instrucciones específicas para cada serie publicadas en la web www.specialsprings.com

PT Todos os cilindros que podem ser ligados ao sistema e especificamente codificados são fornecidos sem válvula unidireccional, sem pressão e somente com a tampa de fechamento do furo de ligação (Não incluída M90, M200, RV170, RV320). Caso queira-se transformar cilindros autónomos em Cilindros interligados, basta encomendar as conexões e tubos necessários e seguir as instruções específicas para cada série, publicadas no site www.specialsprings.com.

LINKABLE

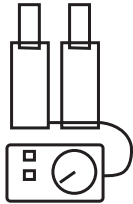

LASER MARKING

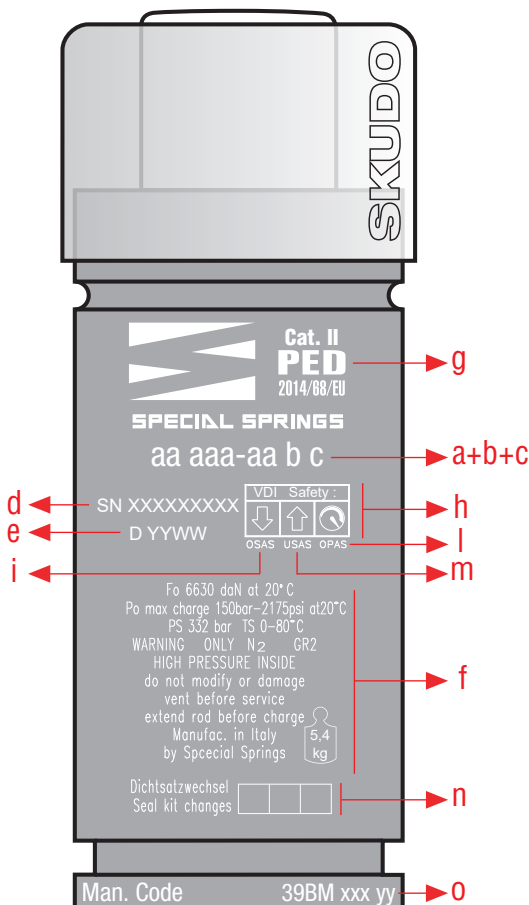

IT

- Codice modello
- Indice revisione
- Versione collegabile a sistema
- Lotto di produzione
- Data di produzione
- Info generali
- Categoria PED
- Pittogrammi sicurezza
- Sicurezza attiva oltre corsa
- Sicurezza attiva oltre pressione
- Sicurezza attiva ritorno incontrollato
- Numero cambi guarnizione
- Kit manutenzione

EN

- Model code
- Revision indicator
- Hosed-system version
- Batch number
- Production date
- General info
- PED Category
- Safety pictograms
- Over stroke active safety
- Over pressure active safety
- Uncontrolled speed active safety
- Number of seal replacements
- Maintenance kit

DE

- Modellcode
- Revisionsindex
- Version kann an ein System angeschlossen werden
- Produktionsserie
- Herstellungsdatum
- Allgemeine Informationen
- PED Kategorie
- Sicherheitspiktogramme
- Aktive Überhubsicherung
- Aktive Überdrucksicherheitsvorrichtung
- Aktiver Schutz bei unkontrolliertem Rückhub
- Anzahl der Dichtungswechsel
- Wartungsset

FR

- Référence modèle
- N de révision
- Version pouvant être reliée à un système
- Lot de production
- Date de fabrication
- Information générales
- Catégorie PED
- Pictogrammes de sécurité
- Securité active outre-course
- Securité active outre-pression
- Securité Active pour Retour Incontrôlé
- Nombre de remplacements du joints
- Set manutention

ES

- Código de modelo
- Indicador de revisión
- Versión conectable a sistema
- Lote de producción
- Fecha de fabricación
- Información general
- Categoría PED
- Pictogramas de seguridad
- Seguridad activa de fin de carrera
- Seguridad activa de sobre presión
- Seguridad Activa de Retorno Incontrolado
- Número de sustituciones de la junta
- Set mantenimiento

PT

- Código do modelo
- Índice de revisão
- Versão que pode ser ligada em sistema
- Lote de produção
- Data de produção
- Informações gerais
- Classe de risco PED
- Pictogramas de segurança
- Segurança ativa mecânica
- Segurança ativa sobrepressão
- Segurança para Retorno da Haste
- Número das substituições da vedação
- Manutenção de conjunto

IT Nel catalogo per tutti i modelli sono indicate sia la forza finale isotermica che politropica.

La forza finale isotermica con 100% Cu è il valore della forza calcolato in condizioni statiche.

La forza finale politropica con 100% Cu è un valore più realistico da considerare quando il cilindro ad azoto è in funzione. Proprio per questo, va calcolata caso per caso, perché soggetta a variazioni della temperatura del gas dipendenti da corsa nominale, corsa di lavoro, velocità della pressa, no. dei cicli al minuto, volume del gas, temperatura dell'ambiente e di lavoro etc.

Special Springs, a titolo informativo, indica anche i valori approssimati di forza politropica calcolati a regime termico, 100% Cu, 30 SPM, velocità pressa costante e temperatura ambiente 20°C. Per maggiori informazioni contattare Special Springs.

EN Both the isothermal and polytropic end forces are indicated in the catalog for all models.

The isothermal end force at 100% Cu is a value calculated in static conditions.

The polytropic end force, at 100% Cu is a more realistic value consider when the gas spring is working. The polytropic force changes case-by-case, since it is subject to variations in the gas temperature depending on the nominal stroke, working stroke, press speed, number of cycles per minute (SPM), volume of gas, room temperature etc.

For user information, Special Springs, indicates the approximated values of polytropic force calculated at thermal regime, 100% Cu, ca 30 SPM constant press speed and room temperature at around 20°C. For further details please contact Special Springs.

F_{1i}
isothermal
end force

DE In unserem Katalog ist für alle Gasdruckfedern sowohl die isotherme als auch die polytrope Endkraft angegeben.

Die isotherme Endkraft bei 100% Cu ist ein Wert, der unter beinahe statischen Bedingungen ermittelt worden ist.

Die polytrope Endkraft bei 100% Cu ist ein realistischerer Wert, wenn die Gasdruckfeder in Betrieb ist. Aus diesem Grund ändert sich die polytrope Kraft von Fall zu Fall, da sie Schwankungen der Gastemperatur in Abhängigkeit von Nennhub, Arbeitshub, Pressengeschwindigkeit, Hubzahl pro Minute (SPM), Gasmenge, Raumtemperatur etc. unterliegt.

Special Springs gibt jedoch zur Information auch den annähernde Wert der polytropen Kraft an, der bei stabiler Betriebstemperatur, 100% Cu, ca. 30 Hübe pro Minute, konstanter Pressengeschwindigkeit und ca. 20° C Raumtemperatur ermittelt worden ist. Für weitere Informationen wenden Sie sich bitte direkt an Special Springs.

F_{1p}
Polytropic
end force

FR Pour tous les modèles, on indique sur le catalogue, soit la force finale isothermique, que celle polytrophique.

La force finale isotherme, avec 100% Cu, est une valeur calculée sur des conditions statiques.

La force finale polytrophique, avec 100% Cu, est une valeur plus réaliste à considérer lorsque le ressort à gaz fonctionne. La force polytrophique change au cas par cas, car elle est soumise aux variations de la température du gaz en fonction de la course nominale, de la course de travail, de la vitesse de la presse, du nombre de cycles par minute, du volume de gaz, de la température ambiante, etc.

Special Springs, cependant, à des buts d'information, indique aussi les valeurs approximés de la force polytrophique calculés au régime thermique, 100% Cu, environ. 30 SPM, presse à vitesse constante et température ambiante 20 °C. Pour tous renseignements complémentaires, contactez Special Springs.

ES Para todos los modelos se indican en el catálogo tanto la fuerza final isotérmica como la politrópica.

La fuerza final isotérmica con 100% de Cu es el valor de fuerza calculado en condiciones estáticas.

La fuerza final politrópica con 100% de Cu es un valor más realista que se debe considerar cuando el cilindro está en funcionamiento. Por esta razón esta fuerza se calcula para cada caso particular ya que está sujeta a variaciones de la temperatura del gas que dependen de la carrera nominal, carrera de trabajo, velocidad de la prensa, número de ciclos por minuto, volumen de gas, temperatura ambiente y de trabajo, etc

Special Springs sin embargo, a título informativo, indica los valores aproximados de fuerza politrópica calculados a régimen térmico, 100% Cu, 30 ciclos/minuto, velocidad constante de prensa y temperatura ambiente de 20 °C. Para más información póngase en contacto con Special Springs.

PT Para todos os modelos, é indicada no catálogo tanto a força final isotérmica, que a politrópica.

A Força Final Isotérmica considerando 100% do curso, é um valor calculado teórico.

A Força Final Politrópica considerando 100% do curso, é um valor mais realista para ser considerado em condições de trabalho. A Força Politrópica irá mudar caso a caso, pois esta sujeita a variações de temperatura do gas dependendo do curso nominal, curso de trabalho, velocidade da prensa, mumeros de golpes por minuto, volume do gas, temperatura ambiente, etc...

Special Springs, no entanto, para fins de informação, indica os valores aproximados da força politrópica calculados a regime térmico 100% Cu, ca. 30 SPM, velocidade constante de prensas e temperatura ambiente a. 20 °C. Para mais informações contacte Special Springs.



$$F_0 = P \cdot S$$

IT Per calcolare la forza iniziale (Fo) di un cilindro ad azoto è sufficiente moltiplicare la pressione di caricamento massima (P) per l'area di tenuta, stelo o pistone, della guarnizione (S).

EN To calculate the initial force (Fo) of each gas spring, multiply the maximum charging pressure (P) to the area of sealing (S), rod or piston, of the gasket seal.

DE Zur Berechnung der Anfangskraft (Fo) einer Gasdruckfeder, muss der angegebene maximale Befülldruck (P) mit der von der Dichtung (S) abgedichteten Fläche an Kolbenstange oder Kolben multipliziert werden.

FR Pour calculer la force initiale (Fo) d'un cylindre à gaz, il suffit de multiplier la pression maximum de chargement (P) pour la surface de retenue, tige ou piston, du joint (S).

ES Para calcular la fuerza inicial (Fo) de un cilindro de gas, se multiplica la presión máxima de carga (P) por la superficie de estanqueidad, vástago o pistón, de los retenes (S).

PT Para calcular a força inicial (Fo) de um cilindro a gás, basta multiplicar a pressão de carga máxima (P) pela área de estanquidade do haste/pistão, da guarnição.

Isothermal force

Metric units

$$F_{x_i} = P \cdot S \cdot \left(\frac{1}{1 - \frac{S}{V_0} \cdot C_x} \right)^n$$

Imperial units

$$F_{x_i} = P \cdot S \cdot \left(\frac{1}{1 - \frac{S}{V_0} \cdot C_x} \right)^n$$

Tab. 1

P	n
≤100 bar	1,09
150 bar	1,19
200 bar	1,31

IT Per calcolare la forza intermedia isoterma (Fx_i) ad una determinata corsa di lavoro (Cx) applicare la formula sostituendo i relativi valori numerici. L'esponente (n) varia in funzione della pressione di caricamento (P) come indicato nella Tab.1. Per valori intermedi di pressione è possibile calcolare il valore di (n) proporzionalmente.

EN To calculate the intermediate isothermal force (Fx_i) to a specific working stroke (Cx), use the formula by replacing the relative numeric values. The exponent (n) varies in function of the charging pressure (P) as indicated in Tab.1. For intermediate pressure values, it is possible to calculate the (n) value proportionally.

DE Zur Berechnung der isothermischen Zwischenkraft (Fx_i) bei einem bestimmten Arbeitshub (Cx) verwenden Sie die nebenstehende Formel und setzen Sie entsprechend die im Katalog angegebenen Werte ein. Der Exponent (n) ist abhängig von dem Befülldruck (P). Mit Hilfe der Angaben in der Tab.1 können Zwischenwerte des Druckes proportional berechnet werden.

FR Pour calculer la force intermédiaire isothermique (Fx_i) d'un ressort à gaz à une course de travail saisie (Cx), vous devez utiliser cette formule en substituant les chiffres relatifs aux valeurs numériques. L'Exposant (n) varie en fonction de la pression de chargement (P), comme montré dans le Tab.1. Pour les valeurs intermédiaires de pression, il est possible de calculer la valeur (n) de façon proportionnelle.

ES Para calcular la fuerza isoterma intermedia (Fx_i) para una carrera de trabajo determinada (Cx) aplicar la formula sustituyendo los valores numéricos correspondientes. El exponente (n) varia en función de la presión de carga (P) tal y como se muestra en Tab.1. Para valores intermedios de presión, es posible calcular el valor de (n) de manera proporcional.

PT Para calcular a força isotérmica intermediária (Fx_i) para um determinado curso de trabalho (Cx) aplicar a fórmula através da substituição dos valores numéricos relevantes. O expoente (n) varia em função da pressão de carga (P), como mostrado na Tab.1. Para os valores intermédios de pressão, é possível calcular o valor de (n) proporcionalmente.

Polytropic force

Metric units

$$F_{x_p} = P \cdot S \cdot \left(\frac{1}{1 - \frac{S}{V_0} \cdot C_x} \right)^{1,58}$$

Imperial units

$$F_{x_p} = P \cdot S \cdot \left(\frac{1}{1 - \frac{S}{V_0} \cdot C_x} \right)^{1,58}$$

IT Per calcolare un valore approssimato di forza intermedia politropica (Fx_p) ad una determinata corsa di lavoro (Cx) applicare la formula sostituendo i relativi valori numerici. L'esponente (n) per la forza politropica può essere assunto pari a 1,58 per la maggior parte delle normali applicazioni.

EN To calculate the approximated value of polytropic intermediate force (Fx_p) to a specific working stroke (Cx), use the formula by replacing the relative numeric values. The exponent (n) for the polytropic force shall be assumed to be equal to 1,58 for the majority of normal applications.

DE Zur Berechnung der ungefähren polytropischen Zwischenkraft (Fx_p) bei einem bestimmten Arbeitshub (Cx) verwenden Sie die nebenstehende Formel und setzen Sie entsprechend die im Katalog angegebenen Werte ein. Der Exponent (n) beträgt im Normalfall 1,58.

FR Pour calculer la valeur de force polytrophique intermédiaire (Fx_p) d'un ressort à gaz à une course de travail saisie (Cx), vous devez utiliser cette formule en substituant les chiffres relatifs aux valeurs numériques. L'Exposant (n) peut être assumé comme 1,58 pour la majorité d'utilisations courantes.

ES Para calcular un valor aproximado de la fuerza intermedia politrópica (Fx_p) para una carrera de trabajo determinada (Cx), aplicar la formula sustituyendo los valores numéricos correspondientes. Se puede asumir un valor de 1,58 para el exponente (n) de la fuerza politrópica para la mayoría de las aplicaciones normales.

PT Para calcular um valor aproximado da força intermediária politrópica (Fx_p) para um determinado curso de trabalho (Cx), aplicar a fórmula através da substituição dos valores numéricos relevantes. O expoente (n) para a força politrópica pode ser assumido como sendo igual a 1,58 para a maioria das aplicações normais.

$$P_n = \frac{F_n}{S}$$

IT Per determinare la pressione di caricamento necessaria per ottenere una forza (Fn) diversa dalla nominale (Fo) è sufficiente dividere la forza richiesta (Fn) per l'area di tenuta, stelo o pistone, della guarnizione.

EN To determine the pressure level required to achieve a force (Fn) different from the nominal one (Fo), divide the required force (Fn) by the area of sealing, rod or piston, of the gasket seal.

DE Zur Berechnung des benötigten Befülldruckes (Pn) für eine spezifische Anfangskraft (Fn), die von der im Katalog angegebenen Anfangskraft abweicht, muss die gewünschte Anfangskraft (Fn) durch die von der Dichtung abgedichteten Fläche an der Kolbenstange oder Kolben dividiert werden.

FR Pour calculer la pression de chargement nécessaire pour obtenir une force (Fn) différente de la force nominale (Fo) il suffit de diviser la force requise (Fn) par la surface d'étanchéité (tige ou piston) du joint.

ES Para calcular la presión de carga necesaria para obtener una fuerza (Fn) distinta de la nominal (Fo), se divide la fuerza requerida (Fn) entre el área de estanqueidad, vástago o pistón, de los retenes.

PT Para determinar a pressão de carga necessária para obter uma força (Fn) diferente da nominal (Fo), basta dividir a força necessária (Fn) pela área de estanquidade do embolo/pistão, da guarnição.

Max Speed

IT Non superare la velocità massima dello stelo indicata. Velocità superiori possono ridurre la durata dei cilindri.

EN Do not exceed the maximum rod speed indicated. Exceeding speeds can reduce the gas spring's life.

DE Die angegebene max. Geschwindigkeit der Kolbenstange darf nicht überschritten werden. Höhere Geschwindigkeiten können die Lebensdauer der Gasdruckfedern reduzieren.

FR Ne pas excéder la vitesse maximale de la tige indiquée pour chaque modèle. Les vitesses supérieures peuvent réduire la durée des vérins.

ES No exceder la velocidad máxima del vástago indicada para cada modelo. Velocidades más altas pueden reducir la vida útil del cilindro.

PT Não exceda a velocidade máxima da haste indicada para cada modelo. Velocidades mais elevadas podem reduzir a vida útil do cilindro.

SPM Strokes per Minute

IT Per ogni modello è indicato il campo di frequenza massima di utilizzo raccomandata al 100% Cu. Il valore inferiore è riferito alla corsa più lunga, quello superiore alla corsa più breve. Frequenze superiori possono ridurre la durata dei cilindri.

EN The maximum frequency range of use recommended to 100 % Cu is indicated for every model. The lower value is referred to the longest stroke, the higher value refers to the shortest stroke. Higher frequencies can reduce the gas spring duration.

DE Für jeden Typ ist eine empfohlene max. Hubzahl (SPM) unter Berücksichtigung des max. Hubes (Cu) angegeben. Der kleine Wert bezieht sich auf den größten auswählbaren Hub, während der größere Wert sich auf den kleinsten auswählbaren Hub bezieht. Höhere Hubzahlen reduzieren die Lebensdauer der Gasdruckfedern.

FR Pour chaque modèle, on indique le champ de fréquence maximale d'usage recommandé au 100% de Cu. La valeur inférieure se réfère à la course plus longue, tandis que la valeur inférieure à la course plus courte. Fréquences supérieures peuvent réduire la durée des vérins.

ES Para cada modelo se indica el rango de frecuencia máxima de uso recomendada al 100% Cu. El valor inferior indicado es válido para carrera más larga, mientras que el valor superior se es válido para la carrera más corta. Frecuencias superiores pueden reducir la vida útil de los cilindros.

PT Para cada modelo se indica o intervalo de frequência máxima do uso recomendada al 100% Cu. O valor mais baixo é relatado para o curso mais longo, o mais elevado para o curso mais curto. frequências mais elevadas podem reduzir a duração dos cilindros.



IT TUTTI i cilindri ad azoto SPECIAL SPRINGS soddisfano i requisiti previsti dalla Direttiva Europea sulle attrezzature a pressione 2014/68/EU, che si applica nell'Unione Europea dal 19 Luglio 2016. Questa Direttiva regola e definisce come attrezzature a pressione i recipienti, le tubazioni e gli accessori sottoposti a una pressione massima ammissibile PS superiore a 0,5 bar. Più specificatamente, la Direttiva 2014/68/EU prevede la classificazione in categorie e l'obbligo di marcatura CE con il numero identificativo del produttore per le attrezzature il cui risultato della pressione P (bar) x il volume del fluido Vo (dm³) sia pari o superiore a 50. La marcatura CE è obbligatoria per le Categorie II e III, ma facoltativa per la Categoria I. Per tutti i cilindri ad azoto il cui prodotto P x Vo è inferiore a 50 si applica l'Articolo 4.3 della Direttiva e non sono marcati CE.

EN ALL Special Springs gas springs fulfill the requirements of the European directive concerning pressure equipment (2014/68/EU), applied in the European Union from 19th July 2016. This directive sets out the standards for pressure equipment and defines them as vessels, piping and accessories subject to a maximum allowable pressure PS greater than 0,5 bar. In particular, according to the directive 2014/68/EU, pressure equipments are classified by category and they shall bear the CE marking with the identification number of the manufacturer when the result of pressure P(bar) X fluid volume Vo(dm³) is 50 or more. The CE marking is mandatory for Categories II and III, but discretionary for Category I. All gas springs which result of P x Vo is less than 50 are subject to Article 4.3 of the same directive and they do not bear the CE marking.

DE Alle Stickstoff-Gasdruckfedern von Special Springs erfüllen die Anforderungen der ab dem 19. Juli 2016 in der Europäischen Union anzuwendenden Richtlinie 2014/68/EU über die Druckgeräte. Diese Richtlinie legt die Anforderungen an die Druckgeräte fest und definiert diese als Behälter, Rohrleitungen und Ausrüstungsteile mit einem max. zulässigen inneren Überdruck (PS) von mehr als 0,5 bar. Im Einzelnen werden Druckgeräte gemäß der Richtlinie 2014/68/EU in Kategorien eingestuft und müssen mit der CE-Kennzeichnung und der Identifikationsnummer des Herstellers beschriftet werden, wenn der errechnete Wert des Produktes von Druck (P) multipliziert mit dem Befüllungsvolumen Vo (dm³) größer als 50 ist. Die CE-Kennzeichnung ist für die Kategorien II und III zwingend, jedoch nicht für die Kategorie I. Die Gasdruckfedern, bei denen der errechnete Wert des Produktes von Druck (P) multipliziert mit dem Befüllungsvolumen Vo (dm³) kleiner als 50 ist, tragen gemäß dem Artikel 4.3 der genannten Richtlinie keine CE-Kennzeichnung.

FR TOUS les cylindres-ressorts à l'azote de SPECIAL SPRINGS satisfont aux prescriptions de la Directive Européenne sur les équipements sous pression 2014/68/EU, qui s'applique dans l'Union Européenne depuis le 19 juillet 2016. Cette Directive fixe les exigences envers les équipements sous pression et les définit comme les récipients, les tuyauteries et les accessoires soumis à une pression maximale admissible PS supérieure à 0,5 bar. Plus spécifiquement, la Directive 2014/68/EU prévoit la classification en catégories et l'obligation du marquage CE avec le numéro d'identification du fabricant pour les équipements dont le résultat de la pression P (bar) X le volume du fluide Vo (dm³) est de 50 ou plus. Le marquage CE est obligatoire pour les catégories II et III, mais facultatif pour la catégorie I. Tous les cylindres-ressorts à l'azote dont le produit de P X Vo est moins de 50 sont réglementés par l'article 4.3 de la même directive et ne portent pas le marquage CE.

ES TODOS los cilindros de nitrógeno SPECIAL SPRINGS cumplen con los requerimientos de la Directiva Europea sobre equipos a presión 2014/68/EU, que se aplica en toda la Unión Europea a partir del 19 de julio de 2016. Esta Directiva regula y define como equipos a presión los recipientes, mangueras y accesorios sometidos a una presión máxima admisible PS superior a 0,5 bar. Más concretamente, la directiva 2014/68/EU prevé la clasificación en categorías y la obligación de marcado CE con el número identificativo del fabricante para los equipos cuyo resultado de la presión P (bar) x el volumen del fluido Vo (dm³) sea igual o superior a 50. El marcado CE es obligatorio para las categorías II y III, pero facultativa para la categoría I. Todos los cilindros de nitrógeno cuyo resultado P x Vo es inferior a 50 están sujetos al artículo 4.3 de la directiva y no llevan el marcado CE.

PT TODOS os cilindros de nitrogénio Special Springs satisfazem os requisitos da Diretiva Europeia para equipamentos sob pressão 2014/68/EU, que se aplica na União Europeia a partir de 19 de julho de 2016. Esa Diretiva regulamenta os equipamentos sob pressão e os define como os recipientes, os tubagens e os acessórios sujeitos a uma pressão máxima admissível PS superior a 0,5 bar. Em particular, a directiva 2014/68/EU prevê a classificação em categorias e a obrigatoriedade da marcação CE com o número de identificação do fabricante para os equipamentos cujo o resultado de pressão P (bar) X volume fluido Vo(dm³) é igual ou superior a 50. A marcação CE é obrigatória para as categorias II e III, mas discricionária para a categoria I. Todos os cilindros de nitrogénio, através da qual resultam P x Vo é inferior a 50 estão sujeitos ao artigo 4.3 da mesma directiva e não ostentam a marcação CE.

CE
PED
2014/68/EU

IT SPECIAL SPRINGS garantisce che i cilindri ad azoto prodotti e venduti da SPECIAL SPRINGS sono privi di difetti di fabbricazione. La presente Garanzia è valida per un periodo di (2) due anni dalla data di acquisto, o per **200.000 metri lineari** di corsa*, o per **2.000.000 di cicli**, a seconda di quale condizione si verifichi per prima. (***100.000 metri lineari** per la Serie HT)

La Garanzia si applica solo ai cilindri ad azoto installati, utilizzati e riparati secondo le prescrizioni SPECIAL SPRINGS.

In caso di presunto difetto, tutte le informazioni utili – comprese la data di acquisto e le condizioni di utilizzo dei cilindri – dovranno essere notificate a SPECIAL SPRINGS.

Prima di utilizzare i cilindri ad azoto SPECIAL SPRINGS, si raccomanda di fare sempre riferimento alle informazioni sulla sicurezza e sul rispetto delle normative come indicato nel Foglio Istruzioni, nella documentazione tecnica e/o nel sito web www.specialsprings.com.

Per "GARANZIA" si intende la riparazione o la sostituzione gratuita del prodotto riconosciuto da SPECIAL SPRINGS come difettoso nella fabbricazione o nel materiale.

SPECIAL SPRINGS non risponde di eventuali danni causati da negligenza, uso improprio e mancato rispetto delle avvertenze e indicazioni contenute nelle prescrizioni SPECIAL SPRINGS.

Si noti infine che condizioni di lavoro critiche o cause esterne possono ridurre significativamente la durata dei cilindri ad azoto.

Termini legali di garanzia su www.specialsprings.com

EN SPECIAL SPRINGS guarantees that the gas springs manufactured and sold by SPECIAL SPRINGS are free from manufacturing defects. This Warranty is valid for the period of (2) two years from the date of purchase, or for **200,000 linear meters** of stroke*, or for **2,000,000 strokes**, whichever occurs first. (***100,000 linear meters** for the HT Series)

The Warranty is applicable only to gas springs installed, used, and repaired according to SPECIAL SPRINGS guidelines.

In case of alleged defect, all useful information - including the date of purchase and the working conditions of gas springs - shall be notified to SPECIAL SPRINGS.

Before using SPECIAL SPRINGS gas springs, always refer to the information on the safety and the compliance with regulations as indicated in the Instruction Sheet, the technical documentation and/or on the website www.specialsprings.com.

By "WARRANTY" it is meant the repair or free replacement of the product, which is recognized by SPECIAL SPRINGS as defective in manufacture or materials.

SPECIAL SPRINGS is not liable for any damage caused by negligence, misuse and noncompliance with the warning and indications contained in SPECIAL SPRINGS guidelines.

Furthermore, heavy working conditions or external causes may reduce the lifetime of gas springs significantly.

Warranty legal terms on www.specialsprings.com

DE SPECIAL SPRINGS garantiert, dass die von SPECIAL SPRINGS hergestellten und verkauften Gasdruckfedern frei von Herstellungsfehlern sind. Diese Garantie gilt für einen Zeitraum von (2) zwei Jahren ab Kaufdatum oder für **200.000 m Gesamthub*** oder für **2.000.000 Hübe**, je nachdem, was zuerst eintritt. (***100.000 m Gesamthub** für die Baureihe HT)

Die Garantie gilt nur für Gasdruckfedern, die gemäß Special Springs Richtlinien installiert, verwendet und repariert wurden.

Im Falle eines behaupteten Defekts müssen alle nützlichen Informationen - einschließlich des Kaufdatums und der Arbeitsbedingungen der Gasdruckfedern - Special Springs mitgeteilt werden.

Vor der Verwendung von SPECIAL SPRINGS-Gasdruckfedern beachten Sie immer die Informationen zur Sicherheit und Einhaltung der Vorschriften, die in der Gebrauchsanweisung, in der technischen Dokumentation und/oder auf der Website www.specialsprings.com angegeben sind.

Unter „GARANTIE“ versteht sich die Reparatur oder der kostenlose Ersatz eines Produkts, bei dem von SPECIAL SPRINGS Herstellungs- oder Materialfehler anerkannt werden.

SPECIAL SPRINGS haftet nicht für Schäden, die durch Fahrlässigkeit, Missbrauch und Nichtbeachtung von Warnungen und Hinweisen, die in den SPECIAL SPRINGS- Richtlinien angegeben sind, entstanden sind.

Schwere Arbeitsbedingungen oder äußere Ursachen können die Lebensdauer von Gasdruckfedern erheblich verkürzen.

Garantiebedingungen siehe www.specialsprings.com

LIFE WARRANTY





FR SPECIAL SPRINGS garantit que les ressorts à gaz fabriqués et vendus par SPECIAL SPRINGS sont exempts de défauts de fabrication. Cette garantie est valable pour une période de (2) deux ans à compter de la date d'achat, ou pour **200.000 mètres linéaires** de course*, ou pour **2.000.000 de courses**, selon la première éventualité. (***100 000 mètres linéaires** pour la série HT).

La garantie ne s'applique qu'aux ressorts à gaz installés, utilisés et réparés conformément aux directives de SPECIAL SPRINGS.

En cas de défaut présumé, toutes les informations utiles - y compris la date d'achat et les conditions de travail des ressorts à gaz - doivent être communiquées à SPECIAL SPRINGS.

Avant d'utiliser les ressorts à gaz SPECIAL SPRINGS, il faut toujours se référer aux informations relatives à la sécurité et au respect des réglementations indiquées dans la fiche d'instructions, la documentation technique et/ou sur le site www.specialsprings.com.

Par "GARANTIE" on entend la réparation ou le remplacement gratuit du produit, reconnu par SPECIAL SPRINGS comme présentant un défaut de fabrication ou de matériaux.

SPECIAL SPRINGS n'est pas responsable des dommages causés par la négligence, la mauvaise utilisation et le non-respect des avertissements et indications contenus dans les directives de SPECIAL SPRINGS.

En outre, des conditions de travail difficiles ou des causes externes peuvent réduire considérablement la durée de vie des ressorts à gaz.

Conditions légales de garantie sur www.specialsprings.com

ES SPECIAL SPRINGS garantiza que los cilindros de gas producidos y vendidos por SPECIAL SPRINGS están libres de defectos de fabricación. Esta Garantía es válida por un período de (2) dos años a partir de la fecha de compra, o para **200.000 metros lineales** de carrera*, o para **2.000.000 de golpes**, lo que ocurra primero. (***100.000 metros lineales** por la Series HT)

La Garantía se aplica solo a los cilindros de gas instalados, usados y reparados de acuerdo con las pautas de SPECIAL SPRINGS.

En caso de un supuesto defecto, toda las informaciones útiles – incluidas la fecha de compra y las condiciones de uso de los cilindros – deberán ser comunicadas a SPECIAL SPRINGS.

Antes de usar los cilindros de gas SPECIAL SPRINGS, consultar siempre las informaciones de seguridad y de cumplimiento normativo indicadas en la Hoja de Instrucciones, en la documentación técnica y/o en el sitio web www.specialsprings.com.

Por "GARANTÍA" se entiende la reparación o el reemplazo gratuito del producto, que SPECIAL SPRINGS reconoce como defectuoso en la fabricación o en el material.

SPECIAL SPRINGS no se hace responsable de los daños causados por negligencia, uso indebido e incumplimiento de las advertencias e indicaciones contenidas en las pautas de SPECIAL SPRINGS.

Además, condiciones de trabajo críticas o causas externas pueden reducir significativamente la vida útil de los cilindros de gas.

Términos legales de la garantía en www.specialsprings.com

PT A SPECIAL SPRINGS garante que os cilindros de nitrogenio fabricados e vendidos pela SPECIAL SPRINGS estão livres de defeitos de fabricação. Esta garantia é valida por um periodo de 2 anos a contar da data da compra, ou **200.000 metros lineares** de curso utilizado, ou por **2.000.000 de golpes**, o que ocorrer primeiro. (**100.000 metros lineares** para cilindros da Linha HT).

A garantia é valida somente para cilindros instalados, utilizados ou reparados de acordo com as recomendações da SPECIAL SPRINGS.

Em caso de possível defeito, todas as informações necessárias - incluindo a data da compra e as condições de trabalho, deverão ser informadas a SPECIAL SPRINGS.

Antes de iniciar a utilização dos cilindros de nitrogenio da SPECIAL SPRINGS, é recomendado que verifique todas as informações sobre segurança e normas de utilização contidas no folheto de instrução, na documentação tecnica e ou no site www.specialsprings.com.

A "GARANTIA" significa a troca de reparos ou a substituição do produto, em casos reconhecidos pela SPECIAL SPRINGS como um defeito de fabricação ou de matéria prima.

A SPECIAL SPRINGS não se responsabiliza por qualquer defeito causado defeito causado por negligencia, mal uso do produto ou o não obediencia com os cuidados e indicações de uso contidas no manual de utilização da SPECIAL SPRINGS.

Alem disso, condições extremas ou causas externas podem reduzir a vida util dos cilindros de nitrogenio consideravelmente.

Termos legais de garantia, podem ser encontrados no site www.specialsprings.com

LIFE WARRANTY



IT Qualora, dopo un lungo funzionamento o per applicazioni particolarmente gravose, si verificassero delle perdite di pressione, significa che le tenute hanno iniziato ad usurarsi o sono state danneggiate. E' quindi possibile, con l'uso di appositi utensili e kits ed il supporto di specifici video e dettagliate istruzioni, ripristinare le condizioni originarie di tenuta e guida. La manutenzione deve essere eseguita solamente da personale qualificato. Eventuali errori possono essere causa di gravi rischi per la sicurezza o limitare la durata dei cilindri. Prima di eseguire qualsiasi intervento scaricare completamente la pressione e assicurare che lo stelo sia completamente compresso nel corpo.

EN If pressure losses occur after extended use or particularly heavy applications, this indicates that the sealing gaskets are worn or damaged. Using special tools and kits, and with the support of videos and detailed instructions, it is possible to restore the original seal and guide conditions. Maintenance must only be conducted by qualified personnel. Errors would cause serious injury or reduce the working life of the gas springs. Before carrying out any work on the system, fully exhaust all pressure and ensure that the rod is fully retracted into the body.

DE Wird nach langer Betriebstätigkeit oder besonders beanspruchender Verwendung ein Druckverlust festgestellt, bedeutet dies, dass die Dichtungen allmählich abgenutzt sind oder beschädigt wurden. Es ist mit Hilfe von zweckmäßigem Werkzeug oder Sets sowie spezifischen Videos und detaillierten Anweisungen möglich, die Ausgangsbedingungen von Dichtung und Führung wiederherzustellen. Die Wartung sollte nur von qualifiziertem Personal vorgenommen werden. Etwaige Fehler können schwerwiegende Sicherheitsrisiken hervorrufen oder die Lebensdauer der Zylinder einschränken. Entladen Sie den Druck und stellen Sie sicher, dass die Kolbenstange komplett in den Zylinderkörper eingeführt ist, bevor Sie Eingriffe vornehmen.

FR Si des pertes de pression se produisent après un long fonctionnement ou avec des applications particulièrement lourdes, cela signifie que les joints de rétenue ont commencé à s'user ou qu'ils sont endommagés. L'utilisation d'outils et de kits appropriés, ainsi que le support de vidéos spécifiques et d'instructions détaillées permettront de rétablir les conditions d'origine de rétenue et de guidage. La maintenance doit être effectuée uniquement par du personnel qualifié. Les éventuelles erreurs peuvent engendrer de graves risques pour la sécurité ou limiter la durée de vie des cylindres. Avant d'effectuer toute opération, décharger complètement la pression et s'assurer que la tige soit complètement comprimée dans le corps.

ES Si después de un largo funcionamiento o en caso de aplicaciones especialmente difíciles se produjesen pérdidas de presión, podría deberse a que los retenes han comenzado a desgastarse o han sufrido algún desperfecto. En esos casos es perfectamente posible restablecer las condiciones originales de los retenes o del guiado mediante kits de mantenimiento adecuados y videos con instrucciones específicas. El mantenimiento debe ser efectuado única y exclusivamente por personal cualificado. Cualquier error podría causar graves riesgos de seguridad o limitar la vida útil de los cilindros. Antes de cualquier reparación, descargar completamente la presión y asegurarse de que el vástago quede completamente comprimido dentro del cuerpo.

PT Depois de muito tempo de utilização dos cilindros, ou trabalhando em condições severas, os cilindros podem apresentar perda de pressão, isto significa que os elementos vedantes começaram a se desgastar ou estão danificados. Neste caso é possível fazer a troca dos elementos vedantes, mas só deve ser feito com a utilização dos instrumentos e ferramentas corretas, auxílio de videos de treinamento e manual de instrução. A manutenção só deve ser feita por pessoal qualificado. A manutenção incorreta dos cilindros pode causar graves riscos de operação e limitar a vida útil dos cilindros. Antes de executar qualquer intervenção nos cilindros, assegurar que os cilindros estão completamente descarregados.

Download step-by-step guide instructions at: <http://www.specialsprings.com>

IT Come previsto dalle linee guida della direttiva PED 2014/68/EU l'azienda che provvede alla manutenzione dei cilindri marchiati CE dal fabbricante (P x Vo \geq 50) si assume la completa responsabilità di far riesaminare gli stessi da un ente di certificazione accreditato. Diversamente tali manutenzioni potranno essere effettuate esclusivamente da Special Springs.

EN As prescribed by the guidelines of PED 2014/68/EU, the company taking care of the maintenance for gas springs laser marked CE by the producer (P x Vo \geq 50), must get them checked by a certified body. Otherwise, the maintenance can be carried out exclusively by Special Springs.

DE Wie in der Richtlinie PED 2014/68/EU vorgeschrieben übernimmt die Firma, die die Instandhaltung von Gasdruckfedern durchführt, die vom Hersteller mit CE-Kennzeichnung versehen worden sind (P x Vo \geq 50), die volle Verantwortung dafür, diese von einer zugelassenen Zertifizierungsanstalt nachprüfen zu lassen. Andernfalls können diese Instandhaltungsarbeiten ausschließlich von Special Springs durchgeführt werden.

FR Selon le mode prévu par les indications de la directive PED 2014/68/EU, l'entreprise qui s'occupe de l'entretien des cylindres marqués CE par le producteur (P x Vo \geq 50), assume la responsabilité de les faire réexaminer par un institut de certification qualifié. Autrement, les entretiens peuvent être effectués exclusivement par Special Springs.

ES Tal y como prevén las directrices de la directiva PED 2014/68/EU, la empresa que realiza mantenimiento de cilindros marcados CE por el fabricante (P x Vo \geq 50) asume la completa responsabilidad de que sean posteriormente verificados por un ente certificado. De otro modo tales tareas de mantenimiento sólo podrán ser llevadas a cabo por Special Springs.

PT De acordo com as directrizes PED 2014/68/EU a fabrica que fornece a manutenção dos cilindros com a marca CE do fabricante (P x Vo \geq 50) assume a responsabilidade de reexaminar os mesmos por uma entidade de certificação creditada. De outra forma tais manutenções poderão ser efectuadas exclusivamente pela Special Springs.



PED
2014/68/EU





How to Order



Maintenance kits

- IT** Se il codice Man. Code non è riportato sul cilindro ad azoto: 39BM + Codice cilindro completo.
- EN** If Man. Code is not indicated on the gas spring, order: 39BM + complete Part Number.
- DE** Wenn Man. Code auf der Gasdruckfeder nicht vorhanden, bestellen Sie 39BM + vollständige Artikelnummer.
- FR** Si le Man. Code n'est pas indiqué en le cylindre, ordonnez 39BM + Numéro d'Article complet.
- ES** Si el Man. Code no está indicado en el cilindro, pedir 39BM + Código completo del Producto.
- PT** Se a referencia Man Code não estiver escrita no cilindro, favor solicitar 39BM + Código do Produto completo.

EXAMPLE: 39BMRV6600-050 B

- IT** Se presente nel cilindro ad azoto, riportare il codice Man. Code in fase di ordinazione.
- EN** If Man. Code is indicated on the gas spring, specify it on the order.
- DE** Wenn Man. Code auf der Gasdruckfeder vorhanden, bitte in der Bestellung angeben.
- FR** Si le Man. Code est indiqué en le cylindre, précisez-le dans l'ordre.
- ES** Si el Man. Code está indicado en el cilindro, especificarlo en el pedido.
- PT** Se indicado no cilindro, indique o Man. Code na ordem.

EXAMPLE: 39BMRV06600C

- IT** Kit include: Boccola assemblata, Valvola unidirezionale, lubrificante e grasso, Istruzioni di montaggio.
- EN** Kit contains: Assembled bushing, one way valve, lubricant and grease, Instructions sheet.
- DE** Das Set beinhaltet: montierte Buchse, Rückschlagventil, Schmieröl und Schmierfett, Montageanleitung.
- FR** Le kit comprend: Douille assemblée, Soupape unidirectionnelle, lubrifiant, graisse et les instructions pour le montage.
- ES** El Kit contiene: casquillo ensamblado, Válvula unidireccional, lubricante y grasa, Instrucciones de montaje.
- PT** O kit contém: Bucha montada, válvula unidireccional, lubrificante, graxa e instruções de montagem.



- IT** Special Springs rende sempre disponibili i manuali d'uso dei propri prodotti (in forma cartacea o scaricabili da web tramite QR-Code). Consegnare sempre i manuali insieme alle attrezzature che contengono prodotti Special Springs.
- EN** Special Springs always provides user manuals for its products (in printed form or downloadable from the web via QR-Code). It is important to always deliver the manuals together with the equipment containing Special Springs products.
- DE** Special Spings stellt immer für die eigenen Produkte die Bedienungsanleitungen - in der gedruckten Version oder durch Internet Seite mittels QR-Codes herunterladen -zur Verfügung. Wichtig: die Bedienungsanleitungen sind immer der Geräte beizulegen, welche mit Special Springs Produkte ausgerüstet sind.
- FR** Special Springs fournit toujours des manuels d'utilisation pour ses produits (sous forme imprimée ou téléchargeable sur le Web via QR-Code). Il est important de toujours livrer les manuels avec l'équipement contenant les produits Special Springs.
- ES** Special Springs siempre proporciona manuales de usuario para sus productos (en forma impresa o descargables desde la web a través de QR-Code). Es importante entregar siempre los manuales junto con los equipos que contengan productos Special Springs.
- PT** A Special Springs fornece sempre manuais de usuário dos seus produtos (em formato impresso ou por download na web via QR-Code). É importante entregar sempre os manuais junto com os equipamentos que contenham produtos Special Springs.





BENEFITS

RESULT

Less Space

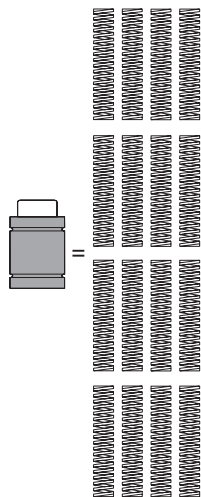

Notevole riduzione della superficie, dello spazio in altezza e del volume occupato. Eliminazione dispositivi di precarico e guidaggio.

Considerable reduction of the required surface, height and volume. No need for retaining and pre-load devices.

Deutliche Reduzierung des Platzbedarfs. Vorrichtungen zum Vorspannen und Führen werden nicht benötigt.

Réduction importante de la surface, de la hauteur et du volume occupés. Élimination de dispositifs de pré-charge et guidage.

Notable reducción de la superficie, de la altura y del volumen ocupados. Eliminación de dispositivos de precarga y guía.

Redução notável da superfície, da altura e do volume ocupados. Eliminação de dispositivos de pré-carga e guidamento.

Lower Height

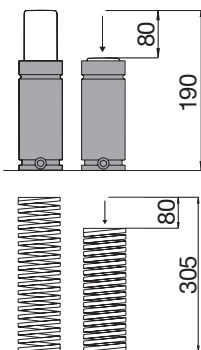

Notevole riduzione degli ingombri in altezza a parità di forza e corsa. Costruzione dello stampo più compatta.

Considerable height reduction for the same working deflection and force. Compact tool construction.

Wesentliche Reduzierung des Höhenbedarfs bei gleichem Hub und gleicher Kraft. Kompaktere Werkzeugkonstruktion.

Réduction importante des encombrements en hauteur avec une course et une force équivalente. Construction plus compacte du moule.

Notable reducción de la altura con igual fuerza y carrera. Construcción más compacta del utillaje.

Redução notável em altura com igual força e curso. Construção mais compacta da Ferramenta.

Save Money

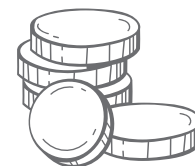

Controlled Force

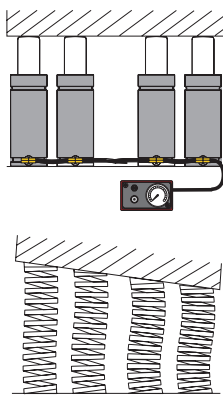

Forza bilanciata e posizionata dove richiesto. Visualizzazione continua della pressione e costante qualità dei pezzi stampati. Maggiore durata degli utensili.

The force is balanced and positioned where required. Pressure is always visible and quality of molded parts is constant. Longer life for tools.

Die Kraft ist stets ausgeglichen und positionierbar an den erforderlichen Stellen. Ständige Anzeige des Betriebsdrucks und konstante Qualität der zu fertigenden Teile. Längere Lebensdauer der Werkzeuge.

La force est équilibrée et positionnée là où elle est exigée. Visualisation continue de la pression et qualité constante des pièces moulées. Durée de vie majeure des outils.

Fuerza equilibrada y dirigida donde se precisa. Visualización continua de la presión y calidad constante de las piezas fabricadas. Mayor duración del utillaje.

Força equilibrada e aplicável onde é necessária. Visualização contínua da pressão e constante qualidade das peças estampadas. Maior duração das ferramentas.

BENEFITS

RESULT

Large initial Force

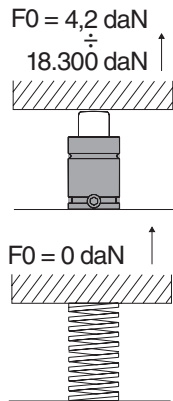

Nessun precarico e maggiore facilità di applicazione.
 No pre-loading needed. Easier and quicker fitting.
 Einfacher Einbau und keine Vorspannung nicht benötigt wird.
 Elimination de la pré-charge et application plus facile.
 Eliminación de la precarga y mayor facilidad de aplicación.
 Eliminação da pré-carga e maior facilidade de aplicação.

Almost Steady Force

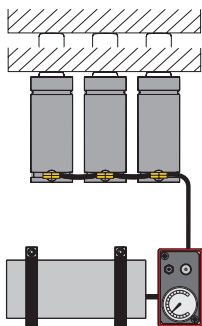

Migliore controllo e riduzione dell'incremento della forza. Migliore qualità dei pezzi stampati e minori scarti di produzione.
 Better control and reduction of force increase. Better quality of molded parts and lower rejection rate in production.
 Bessere Kontrolle und Reduzierung der Krafterhöhung. Bessere Qualität der fertigen Werkstücke und weniger Ausschuss bei der Produktion.
 Meilleur contrôle et réduction de l'augmentation de la force. Une meilleure qualité des pièces moulées et une quantité inférieure de pièces rejetées en production.
 Mejor control y reducción del incremento de la fuerza. Mejor calidad de las piezas fabricadas y disminución de piezas rechazadas en producción.
 Melhor controlo e redução do incremento da força. Melhor qualidade das peças estampadas e menos peças rejeitadas na produção.

Save Money

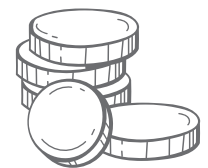

Adjustable Force

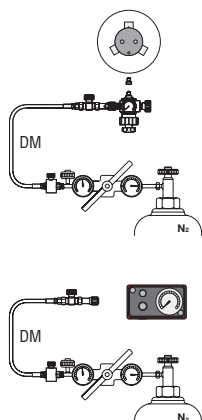

Forze regolabili e flessibilità d'uso.
 Adjustable forces and flexible use.
 Einstellbare Kräfte und flexibler Einsatz.
 Forces réglables et flexibilité d'utilisation.
 Fuerzas regulables y flexibilidad de utilización.
 Forças reguláveis e flexibilidade de utilização.

BENE
FITS

HOW TO READ THE CATALOG



1
2
2

4
5
6
7
8
9
10
11
12
13
14
15
16
17
18

19
20

SC 150

075.90.55 (FCA)	B2 4006 (BMW)	B8 3180 220 000 001(MB)	E24.54.815.G (PSA)
EM24.54.700 (Renault)			

ACTIVE SAFETY

OSAS + OSM = OVER STROKE ACTIVE SAFETY + OVER STROKE MARKER

Il nuovo codice sarà fornito solo ad esaurimento del vecchio
The new code will be supplied only when the old will be out of stock
Der neue Kode wird nur angegeben, wenn der alte nicht mehr lieferbar ist
Le nouveau code sera fourni uniquement lorsque le vieux stock sera écoulé
El nuevo código será suministrado sólo cuando se agoten las existencias del antiguo
O novo código irá ser fornecido apenas quando o antigo esgotar stock

easU p. 247

* F_{1i} = Isothermal end force at 100% Cu p. 16

** F_{1p} = Polytrophic end force at 100% Cu

OSAS + OSM $\varnothing 26 \pm 1.02$

p. 120

N₂

0 - 80 °C
32 - 176 °F

ΔP
± 0,33 %/°C

P max
150 bar
2175 psi

P min
20 bar
290 psi

S
1,13 cm²
0.175 in²

SPM
~ 80 - 100
(at 20°C)

Max Speed
1,8 m/s
70.8 in/s

Maintenance kit
39BMSCO0150E

CODE	PHASING OUT from 04/2021	NEW	Cu		L		L min		F ₀		F _{1i} *		F _{1p} **		V ₀		PED 2014/88/EU									
			mm	inch	mm	inch	mm	inch	daN	lb	daN	lb	daN	lb	cm ³	in ³		-Kg	-lb							
SC 150 - 010 - D	SC 150 - 010 - E	10	0.39	70	2.76	60	2.36	170 382 ± 5% 150 bar 2175 psi + 20 °C +68 °F	192	431	209	469	11,6	0,71	0,28	0,62	✓									
SC 150 - 013 - D	SC 150 - 013 - E	12,7	0,51	75,4	2,97	62,7	2,47											195	438	213	479	13,1	0,80	0,29	0,64	✓
SC 150 - 016 - D	SC 150 - 016 - E	16	0,63	82	3,23	66	2,60											198	445	218	490	14,8	0,90	0,30	0,66	✓
SC 150 - 025 - D	SC 150 - 025 - E	25	0,98	100	3,94	75	2,95											203	457	226	508	20,0	1,22	0,33	0,73	✓
SC 150 - 038 - D	SC 150 - 038 - E	38	1,50	126	4,96	88	3,46											208	467	233	523	27,3	1,67	0,36	0,79	✓
SC 150 - 050 - D	SC 150 - 050 - E	50	1,97	150	5,91	100	3,94											211	473	237	532	34,1	2,08	0,40	0,88	✓
SC 150 - 063 - D	SC 150 - 063 - E	63,5	2,48	177	6,97	113,5	4,47											212	478	239	538	41,7	2,54	0,44	0,97	✓
SC 150 - 080 - D	SC 150 - 080 - E	80	3,15	210	8,27	130	5,12											214	481	242	544	50,9	3,11	0,49	1,08	✓
SC 150 - 100 - D	SC 150 - 100 - E	100	3,94	250	9,84	150	5,91											216	485	245	550	61,6	3,76	0,55	1,21	✓
SC 150 - 125 - D	SC 150 - 125 - E	125	4,92	300	11,81	175	6,89											218	490	247	556	74,7	4,56	0,64	1,41	✓

♦ Disposable

Drop-in

Bottom mount

FS2A 32
FS2B 32

FC 32 A
FCQC 32

FSA 32
FSD 32

HOW TO ORDER p. 121

INSTALLATION GUIDELINE p. 205

122 - 024
Special Springs

<p>1 Modello di cilindro ad azoto Gas spring model Gasdruckfeder Modell Modèle de Ressorts à Gaz Modelo de cilindro de Gas Modelo de cilindro de nitrogênio</p>	<p>2 Modifica rispetto al catalogo precedente > see page 2 Modification respect to the former catalog >see page 2 Modification à l'égard du catalogue précédent > voir page 2 Veränderungen gegenüber den alte Katalog > Siehe Seite 2 Cambios en comparación con el catálogo anterior > ver página 2 Alterações em comparação com o catálogo anterior > ver página 2</p>		
<p>3 Standard internazionali / costruttori auto (ISO, VDI, ecc.) International / Automotive Standards (ISO, VDI, ecc.) Internationale / Automobil-Standards (ISO, VDI, ecc.) Standards internationaux / automobiles (ISO, VDI, ecc.) Estándares internacionales / automóvil (ISO, VDI, ecc.) Padrões internacionais / automóvel (ISO, VDI, ecc.)</p>	<p>4 Raschiatore secondario applicabile Secondary Wiper can be mounted Sekundärabstreifer montierbar Joint racleur secondaire peut être monté Posibilidad de montar rascador secundario. Raspador secundário montável</p>		
<p>5 Dispositivi di sicurezza presenti nel modello Safety devices provided on the model Sicherheitsvorrichtungen am Modell Dispositifs de sécurités présents sur le modèle Dispositivos de seguridad disponibles en el modelo Dispositivos de segurança disponíveis no modelo</p>	<p>6 Gas di caricamento Pressure medium Druckgas Gaz de chargement Gas de carga Gás de carga</p>		
<p>7 Temperatura di esercizio Working temperature Betriebstemperatur Température de fonctionnement Temperatura de funcionamiento Temperatura de funcionamento</p>	<p>8 $\Delta P / \Delta T$</p>		
<p>9 Pressione max di caricamento Max charging pressure Maximaler Ladedruck Pression de chargement maximum Presión máx de carga Pressão máxima de carga</p>	<p>10 Pressione min. di caricamento Min charging pressure Minimaler Ladedruck Pression de chargement minimum Presión mín de carga Pressão mínima de carga</p>		
<p>11 Area di tenuta stelo/pistone Rod/piston seal area Dichtungsbereich Kolbenstange/Kolben Zone d'étanchéité tige/piston Área de estanqueidad vástago/pistón Área de estanquidade do embolo/pistão</p>	<p>12 Cicli / minuto Strokes / minute Hübe/Minute Cycles / minute Ciclos / minuto Pancadas / minuto</p>	<p>13 Codice Code Bestell-Nummer Référence Código Codigo</p>	
<p>14 Forza iniziale a 20°C Initial force at 20°C Anfangskraft bei 20°C Force initiale à 20°C Fuerza inicial a 20°C Força inicial a 20°C</p>	<p>15 Forza finale isoterma Isothermal end force Isothermische Endkraft Force finale isothermique Fuerza final isotérmica Força final isotérmica</p>		
<p>16 Forza finale politropica Polytropic end force Polytropische Endkraft force finale politrophique fuerza finale politrópica força finale politrópica</p>	<p>17 Volume iniziale Initial gas volume Anfangswert Gasvolumen Volume de gaz initial Volumen de gas inicial Volume de gás inicial</p>		
<p>18 Classificazione PED PED classification PED Einstufung Classification PED Clasificación PED Classificação PED</p>	<p>19 Fissaggi Flange mounts Befestigungen Brides de fixation Bridas de fijación Fixação com flange</p>	<p>20 Indice di revisione pagina Page review index Index der Seitenüberprüfung Index de revue de page Índice de revisión de página Índice de revisão de página</p>	
<p> Tutte le dimensioni senza tolleranza si intendono nominali. All dimensions are nominal unless tolerance is stated. Alle Maßangaben ohne Toleranzen sind Nennmaße.</p>			<p>Sauf specifications de tolerances, toutes les dimensions sont des valeurs nominales. Todas las dimensiones son nominales excepto cuando se indica la tolerancia. Todas as medidas são nominais excepto quando a tolerancia é mencionada.</p>

SELECTION TAB

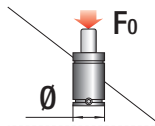

	42 50	70 90	150 200	260 320	360 480	490 680	740 780	900 1000	1046 1410	1530 2000
12	M 50									
15		M 70								
M 16 x 1,5	NG 16 x 1,5 NE 16 x 1,5									
M 16 x 2	NE 16 x 2									
19		M 90 MS 90	MP 150 RV 170 RS 170							
M 24 x 1,5		M 90 TBM M 90 TEM	NG 24 x 1,5 NE 24 X 1,5							
1"- 8 UNC		M 90 TBI								
25			M 200 MS 200	MP 300 ML 300 RV 320 RS 320	KE 400					
32			SC 150 SC 200	M 300 H 300	RV 350 RS 350 RT 350	ML 500 MP 500 MQ 700	KE 750			
38				SC 250	H 500 HT 500 T2 RV 500 RS 500 RT 500	HT 500 T1		ML 1000 MP 1000	KE 1000	
M 38 x 1,5				SCF 250	HF 500					
45					S 500 SC 500	H 700	HT 700 T1 HT 700 T2 RV 750 RS 750 RF 750 RT 750 RG 750			
50							SC 750 S 750	H 1000 HT 1000 T1 HT 1000 T2 RV 1000 RS 1000 RF 1000 RT 1000 RG 1000	RV 1200 RS 1200 RF 1200 RT 1200	KE 1800 ML 1800 MP 2000
63										RV 1500 RS 1500 RF 1500 RT 1500 RG 1500 H 1500
75										S 1500 SC 1500 LS 1500

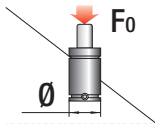

	2035 2385	2830 3000	3180	4240	4418 4980	6630	7540 7700	9540	10600 12720	18400 19910
63		KE 3000 MP 3000	ML 3000							
75	H 2400 LS 2400 RV 2400 RS 2400 RF 2400 RT 2400 RG 2400				KE 4700 ML 4700					
95		LS 3000 S 3000 SC 3000		H 4200 LS 4200 RV 4200 RS 4200 RT 4200 RG 4200			KE 7500 ML 7500			
120					LS 5000 SC 5000	H 6600 LS 6600 RV 6600 RS 6600 RT 6600 RG 6600			KE 12000 ML 12000	
150						SC 7500 LS 7500	H 9500 LS 9500 RV 9500 RS 9500 RT 9500	RV 12000	KE 18500	
195								SC 10000	RV 20000H 18500 H 20000	



NE SERIES

NG SERIES

VDI	Ford	
VDI	BMW	FCA
Ford	GM	

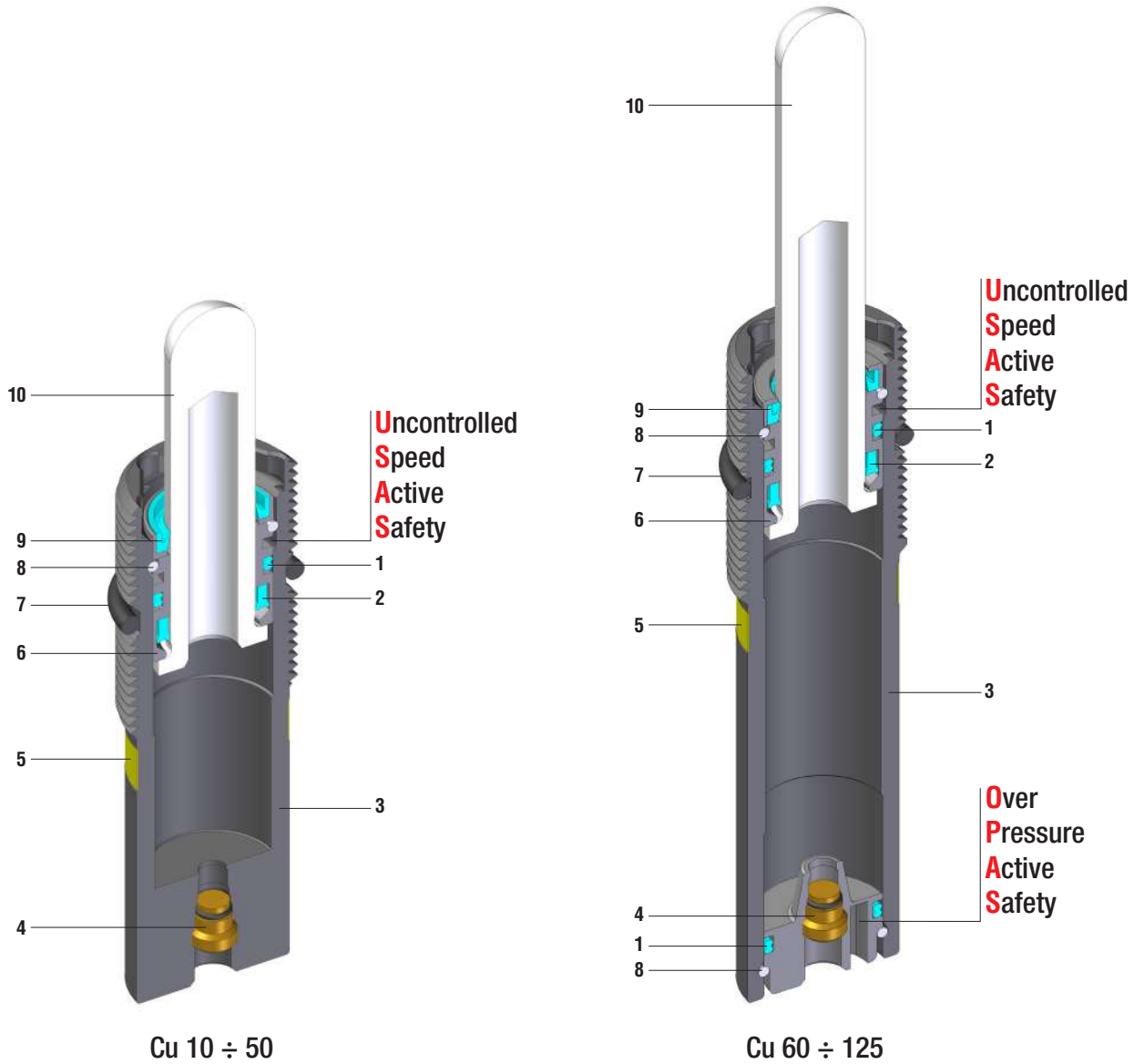

Espulsori a gas - Gas ejectors - Federnde Druckstücke
 Ejectores de gaz - Eyectores de gas - Ejectores a gás

SEALING	ROD SEAL
DESIGN	BUSH - BODY DESIGN

1	Dual ring seal	6	Bush
2	Rod seal	7	Locking ring
3	Body	8	Retaining ring
4	Valve	9	Rod wiper
5	Force color code	10	Rod (nitrited superfinished)

RANGE CHART

Model	Body Ø		Stroke Cu		Initial force F0					
	mm	inch	mm	inch	daN	lb				
NE 16 x 1,5	M 16 x 1,5	M 16 x 1.5	10 - 125	0.39 - 4.92	3 - 42	7 - 95	-	✓	-	-
NE 16 x 2	M 16 x 2	M 16 x 2	10 - 125	0.39 - 4.92	3 - 42	7 - 95	-	✓	-	-
NG 16 x 1,5	M 16 x 1,5	M 16 x 1.5	10 - 100	0.39 - 3.94	3 - 42	7 - 95	-	✓	-	-
NE 24 x 1,5	M 24 x 1,5	M 24 x 1.5	10 - 50	0.39 - 1.97	11 - 170	25 - 382	-	✓	-	-
NE 24 x 1,5	M 24 x 1,5	M 24 x 1.5	60 - 125	2.36 - 4.92	11 - 170	25 - 382	-	✓	✓	-
NG 24 x 1,5	M 24 x 1,5	M 24 x 1.5	10 - 50	0.39 - 1.97	11 - 170	25 - 382	-	✓	-	-
NG 24 x 1,5	M 24 x 1,5	M 24 x 1.5	60 - 100	2.36 - 3.94	11 - 170	25 - 382	-	✓	✓	-

NE
NG



HOW TO ORDER

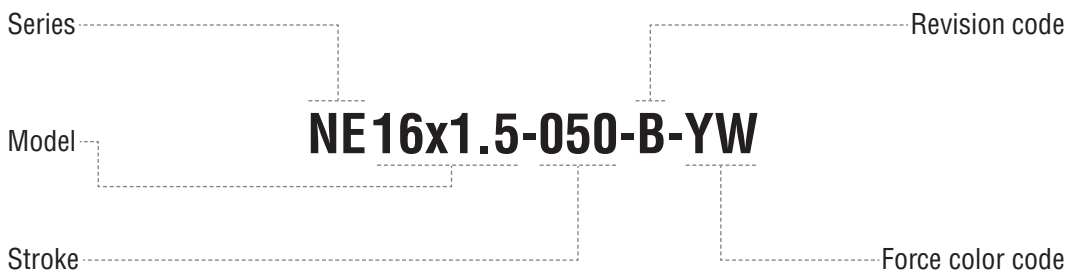

Available versions



NE 16x1.5-050-B-YW

Standard code



Self contained

ACTIVE SAFETY



USAS

* $F_{1i} =$

Isothermal end force at 100% Cu



p. 16



** $F_{1p} =$

Polytropic end force at 100% Cu

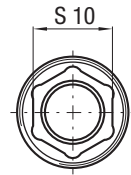
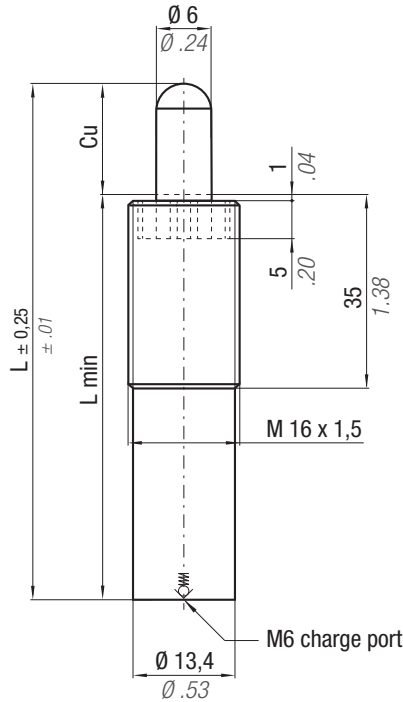

cod. 39CM01A (optional)

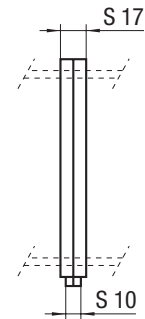

	0 - 80 °C 32 - 176 °F	ΔP ± 0,33 %/°C	P max 150 bar 2175 psi	P min 10 bar 145 psi	S 0,28 cm ² 0.043 in ²	SPM ~ 50 - 100 (at 20°C)	Max Speed 1,8 m/s 70.8 in/s	Maintenance kit Disposable
--	--------------------------	---------------------------	-------------------------------------	-----------------------------------	-----------------------------------------------------------	---------------------------------------	------------------------------------------	--------------------------------------

CODE	Cu		L		L min		~Kg		PED 2014/68/EU	Force color code	P		F ₀ Initial force ± 5%		F _{1i} End force*	F _{1p} End force**
	mm	inch	mm	inch	mm	inch					bar	psi	daN	lb		
NE 16 x 1,5-010-B-...	10	0.39	65	2.56	55	2.17	0,05	0.11	✓							
NE 16 x 1,5-020-B-...	20	0.79	85	3.35	65	2.56	0,06	0.13	✓							
NE 16 x 1,5-030-B-...	30	1.18	105	4.13	75	2.95	0,07	0.15	✓							
NE 16 x 1,5-040-B-...	40	1.57	125	4.92	85	3.35	0,07	0.15	✓							
NE 16 x 1,5-050-B-...	50	1.97	145	5.71	95	3.74	0,08	0.18	✓							
NE 16 x 1,5-060-B-...	60	2.36	165	6.50	105	4.13	0,08	0.18	✓							
NE 16 x 1,5-070-B-...	70	2.76	185	7.28	115	4.53	0,09	0.20	✓							
NE 16 x 1,5-080-B-...	80	3.15	205	8.07	125	4.92	0,10	0.22	✓							
NE 16 x 1,5-100-B-...	100	3.94	245	9.65	145	5.71	0,11	0.24	✓							
NE 16 x 1,5-125-B-...	125	4.92	295	11.61	170	6.69	0,12	0.26	✓							

Pressione da specificare in fase d'ordine.
Pressure to be specified when ordering.
Druck bei Bestellung anzugeben.
Pression à préciser lors de la commande.
La presión se debe especificar al realizar el pedido.
Pressão a ser especificada no pedido.

P = nominal charging pressure

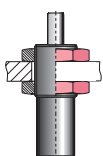

DM 16

HOW TO ORDER

p. 31

INSTALLATION GUIDELINE

p. 205

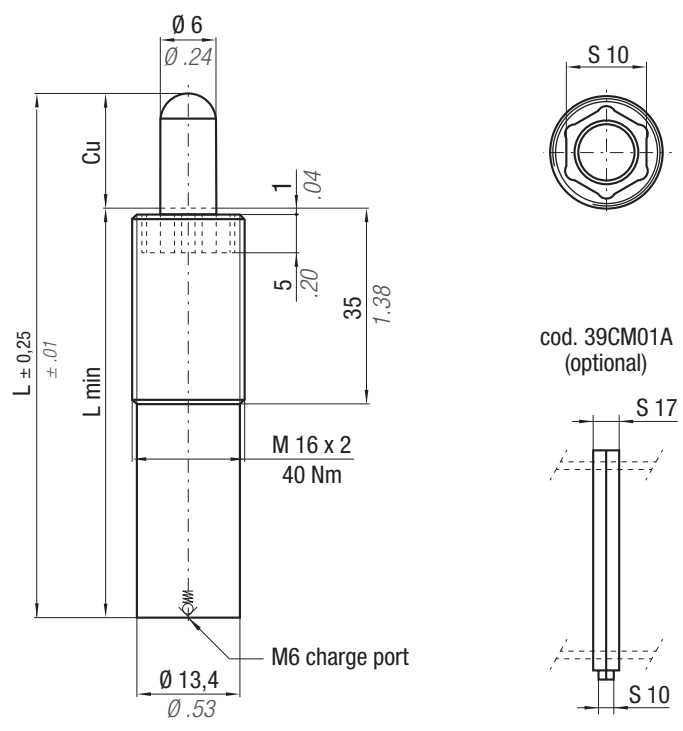

* $F_{1i} =$ Isothermal end force at 100% Cu p. 16

** $F_{1p} =$ Polytrophic end force at 100% Cu

ACTIVE SAFETY



NE
NG

	0 - 80 °C 32 - 176 °F	ΔP ± 0,33 %/°C	P max 150 bar 2175 psi	P min 10 bar 145 psi	S 0,28 cm ² 0.043 in ²	SPM ~ 50 - 100 (at 20°C)	Max Speed 1,8 m/s 70.8 in/s	Maintenance kit Disposable
--	--------------------------	---------------------------	-------------------------------------	-----------------------------------	-----------------------------------------------------------	---------------------------------------	------------------------------------------	--------------------------------------

CODE	Cu		L		L min		Weight		PED 2014/68/EU	Force color code	P		F ₀ Initial force ± 5%		F _{1i} End force*	F _{1p} End force**
	mm	inch	mm	inch	mm	inch	~Kg	~lb			bar	psi	daN	lb		
NE 16 x 2-010-B-...	10	0.39	65	2.56	55	2.17	0,05	0.11	✓							
NE 16 x 2-020-B-...	20	0.79	85	3.35	65	2.56	0,06	0.13	✓							
NE 16 x 2-030-B-...	30	1.18	105	4.13	75	2.95	0,07	0.15	✓							
NE 16 x 2-040-B-...	40	1.57	125	4.92	85	3.35	0,07	0.15	✓							
NE 16 x 2-050-B-...	50	1.97	145	5.71	95	3.74	0,08	0.18	✓							
NE 16 x 2-060-B-...	60	2.36	165	6.50	105	4.13	0,08	0.18	✓							
NE 16 x 2-070-B-...	70	2.76	185	7.28	115	4.53	0,09	0.20	✓							
NE 16 x 2-080-B-...	80	3.15	205	8.07	125	4.92	0,10	0.22	✓							
NE 16 x 2-100-B-...	100	3.94	245	9.65	145	5.71	0,11	0.24	✓							
NE 16 x 2-125-B-...	125	4.92	295	11.61	170	6.69	0,12	0.26	✓							

Pressione da specificare in fase d'ordine.
Pressure to be specified when ordering.
Druck bei Bestellung anzugeben.
Pression à préciser lors de la commande.
La presión se debe especificar al realizar el pedido.
Pressão a ser especificada no pedido.

P = nominal charging pressure

39DM16X2A

HOW TO ORDER p. 31

INSTALLATION GUIDELINE p. 205

ACTIVE SAFETY



USAS



OPAS

* $F_{1i} =$

Isothermal
end force
at 100% Cu



p. 16



** $F_{1p} =$

Polytropic
end force
at 100% Cu

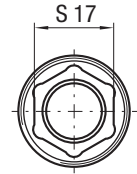
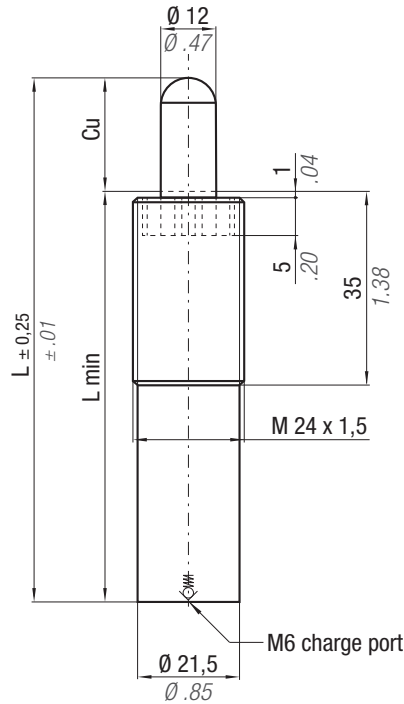

cod. 39CM01A
(optional)

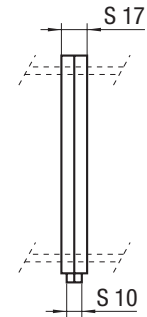

	0 - 80 °C 32 - 176 °F	ΔP ± 0,33 %/°C	P max 150 bar 2175 psi	P min 10 bar 145 psi	S 1,13 cm ² 0.175 in ²	SPM ~ 50 - 100 (at 20°C)	Max Speed 1,8 m/s 70.8 in/s	Maintenance kit Disposable
--	--------------------------	---------------------------	-------------------------------------	-----------------------------------	-----------------------------------------------------------	---------------------------------------	------------------------------------------	--------------------------------------

CODE	Cu		L		L min		~Kg		PED 2014/68/EU	Force color code	P		F0 Initial force ± 5%		F _{1i} End force*	F _{1p} End force**
	mm	inch	mm	inch	mm	inch					bar	psi	daN	lb		
NE 24 x 1,5-010-B-...	10	0.39	65	2.56	55	2.17	0,16	0.35	✓							
NE 24 x 1,5-020-B-...	20	0.79	85	3.35	65	2.56	0,18	0.40	✓							
NE 24 x 1,5-030-B-...	30	1.18	105	4.13	75	2.95	0,20	0.44	✓							
NE 24 x 1,5-040-B-...	40	1.57	125	4.92	85	3.35	0,23	0.51	✓							
NE 24 x 1,5-050-B-...	50	1.97	145	5.71	95	3.74	0,25	0.55	✓							
NE 24 x 1,5-060-B-...	60	2.36	165	6.50	105	4.13	0,27	0.59	✓							
NE 24 x 1,5-070-B-...	70	2.76	185	7.28	115	4.53	0,29	0.64	✓							
NE 24 x 1,5-080-B-...	80	3.15	205	8.07	125	4.92	0,30	0.66	✓							
NE 24 x 1,5-100-B-...	100	3.94	245	9.65	145	5.71	0,33	0.73	✓							
NE 24 x 1,5-125-B-...	125	4.92	295	11.61	170	6.69	0,35	0.77	✓							

Pressione da specificare in fase d'ordine.
Pressure to be specified when ordering.
Druck bei Bestellung anzugeben.
Pression à préciser lors de la commande.
La presión se debe especificar al realizar el pedido.
Pressão a ser especificada no pedido.

P = nominal charging pressure

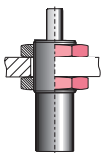

DM 24

HOW TO ORDER

p. 31

INSTALLATION GUIDELINE

p. 205

VDI 3004	B2 4036 (BMW)	075.90.40 (FCA)	W-DX35-60M (Ford)
B8 0820 100 000 002(MB)	90.25.97 (GM)	90.25.28 (GM)	

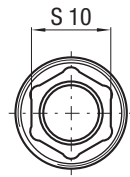
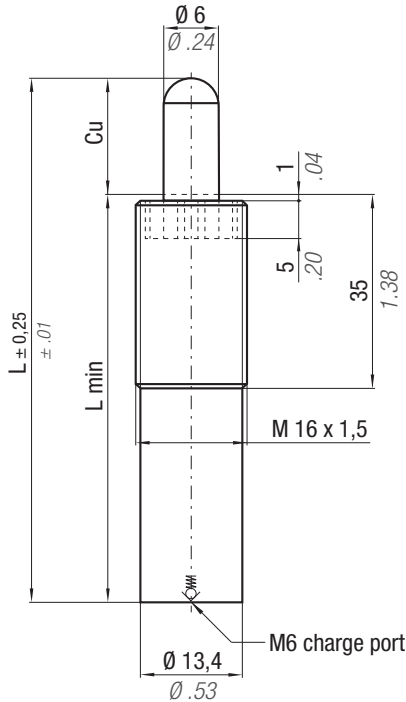

cod. 39CM01A
(optional)

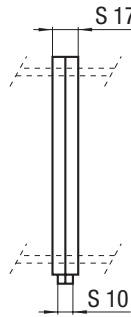

* $F_{1i} =$

Isothermal
end force
at 100% Cu

p. 16

** $F_{1p} =$

Polytropic
end force
at 100% Cu

**ACTIVE
SAFETY**



NE
NG

	0 - 80 °C 32 - 176 °F	ΔP ± 0,33 %/°C	P max 150 bar 2175 psi	P min 10 bar 145 psi	S 0,28 cm ² 0.043 in ²	SPM ~ 50 - 100 (at 20°C)	Max Speed 1,8 m/s 70.8 in/s	Maintenance kit Disposable
--	--------------------------	---------------------------	-------------------------------------	-----------------------------------	-----------------------------------------------------------	---------------------------------------	------------------------------------------	--------------------------------------

CODE	Cu		L		L min		~Kg			Force color code	P		F ₀ Initial force ± 5%		F _{1i} End force*	F _{1p} End force**
	mm	inch	mm	inch	mm	inch	~Kg	~lb			bar	psi	daN	lb		
NG 16 x 1,5-010-A-...	10	0.39	80	3.15	70	2.76	0,05	0.11	✓							
NG 16 x 1,5-020-A-...	20	0.79	100	3.94	80	3.15	0,06	0.13	✓							
NG 16 x 1,5-030-A-...	30	1.18	120	4.72	90	3.54	0,07	0.15	✓							
NG 16 x 1,5-040-A-...	40	1.57	140	5.51	100	3.94	0,07	0.15	✓							
NG 16 x 1,5-050-A-...	50	1.97	160	6.30	110	4.33	0,08	0.18	✓							
NG 16 x 1,5-060-A-...	60	2.36	180	7.09	120	4.72	0,08	0.18	✓							
NG 16 x 1,5-070-A-...	70	2.76	200	7.87	130	5.12	0,09	0.20	✓							
NG 16 x 1,5-080-A-...	80	3.15	220	8.66	140	5.51	0,10	0.22	✓							
NG 16 x 1,5-100-A-...	100	3.94	260	10.24	160	6.30	0,11	0.24	✓							

**Pressione da specificare in fase d'ordine.
Pressure to be specified when ordering.
Druck bei Bestellung anzugeben.
Pression à préciser lors de la commande.
La presión se debe especificar al realizar el pedido.
Pressão a ser especificada no pedido.**

P = nominal charging pressure

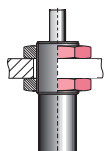

DM 16

HOW TO ORDER

p. 31

INSTALLATION GUIDELINE

p. 205

NG 24 x 1.5

VDI 3004 90.25.95 (GM)	075.90.40 (FCA) 90.25.96 (GM)	W-DX35-60M (Ford)	B8 0820 100 000 002(MB)
---------------------------	----------------------------------	-------------------	-------------------------



ACTIVE SAFETY



USAS



OPAS

* $F_{1i} =$

Isothermal
end force
at 100% Cu



p. 16



** $F_{1p} =$

Polytropic
end force
at 100% Cu

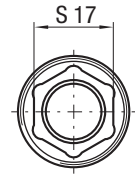
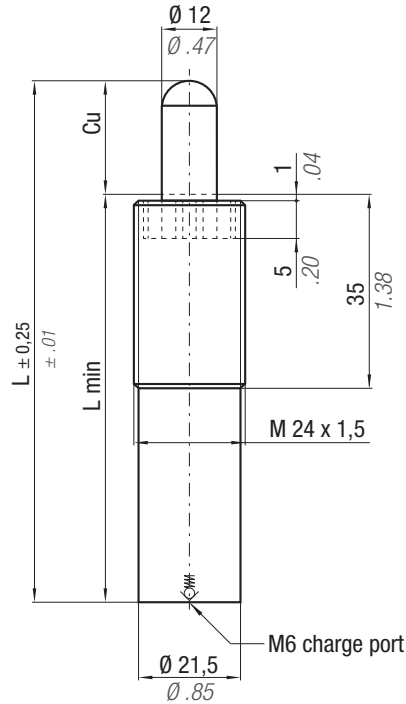

cod. 39CM01A
(optional)

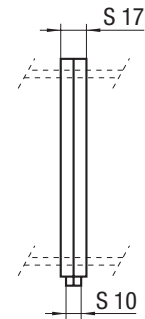

N ₂	0 - 80 °C 32 - 176 °F	ΔP ± 0,33 %/°C	P max 150 bar 2175 psi	P min 10 bar 145 psi	S 1,13 cm ² 0,175 in ²	SPM ~ 50 - 100 (at 20°C)	Max Speed 1,8 m/s 70,8 in/s	Maintenance kit Disposable
----------------	--------------------------	---------------------------	-------------------------------------	-----------------------------------	-----------------------------------------------------------	---------------------------------------	------------------------------------------	--------------------------------------

CODE	Cu		L		L min		~Kg		 2014/68/EU	Force color code	P		F ₀ Initial force ± 5%		F _{1i} End force*	F _{1p} End force**	
	mm	inch	mm	inch	mm	inch					bar	psi	daN	lb			
NG 24 x 1,5-010-A-...	10	0.39	80	3.15	70	2.76	0,15	0.33	✓								
NG 24 x 1,5-020-A-...	20	0.79	100	3.94	80	3.15	0,17	0.37	✓	GR	20	290	23	52	1,57 x F ₀	2,01 x F ₀	
NG 24 x 1,5-030-A-...	30	1.18	120	4.72	90	3.54	0,19	0.42	✓	BU	40	580	45	101	1,57 x F ₀	2,01 x F ₀	
NG 24 x 1,5-040-A-...	40	1.57	140	5.51	100	3.94	0,22	0.49	✓	BR	60	870	67	151	1,57 x F ₀	2,01 x F ₀	
NG 24 x 1,5-050-A-...	50	1.97	160	6.30	110	4.33	0,24	0.53	✓	RD	75	1088	85	191	1,57 x F ₀	2,01 x F ₀	
NG 24 x 1,5-060-A-...	60	2.36	180	7.09	120	4.72	0,26	0.57	✓	YW	150	2175	170	382	1,57 x F ₀	2,01 x F ₀	
NG 24 x 1,5-070-A-...	70	2.76	200	7.87	130	5.12	0,28	0.62	✓	BK	10-150	145-2175	11-170	25-382	1,57 x F ₀	2,01 x F ₀	
NG 24 x 1,5-080-A-...	80	3.15	220	8.66	140	5.51	0,29	0.64	✓								
NG 24 x 1,5-100-A-...	100	3.94	260	10.24	160	6.30	0,31	0.68	✓								

Pressione da specificare in fase d'ordine.
Pressure to be specified when ordering.
Druck bei Bestellung anzugeben.
Pression à préciser lors de la commande.
La presión se debe especificar al realizar el pedido.
Pressão a ser especificada no pedido.

P = nominal charging pressure

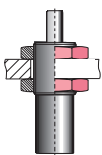

DM 24

HOW TO ORDER

p. 31

INSTALLATION GUIDELINE

p. 205



THIS PAGE IS INTENTIONALLY LEFT BLANK

VDI	BMW	FCA
Ford	MB	Nissan
PSA	VW	

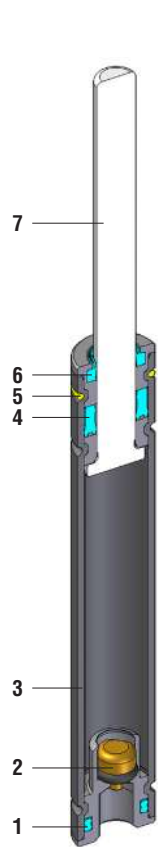

M 50 - M 70

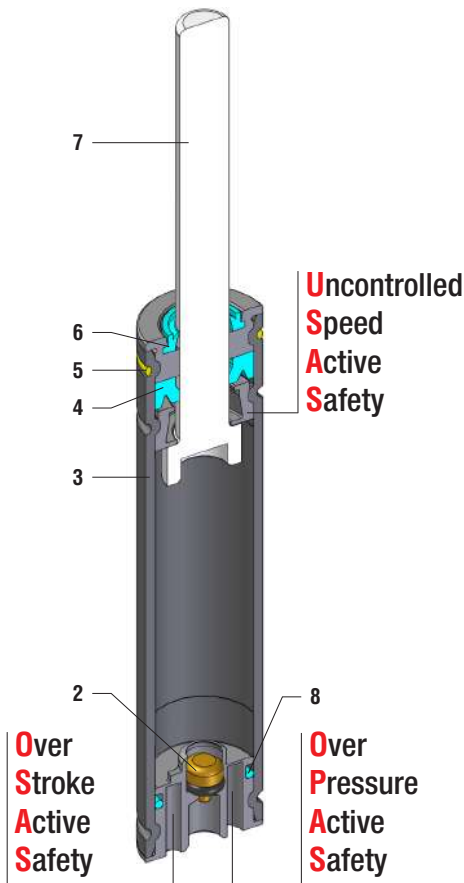

M 90 - M 200

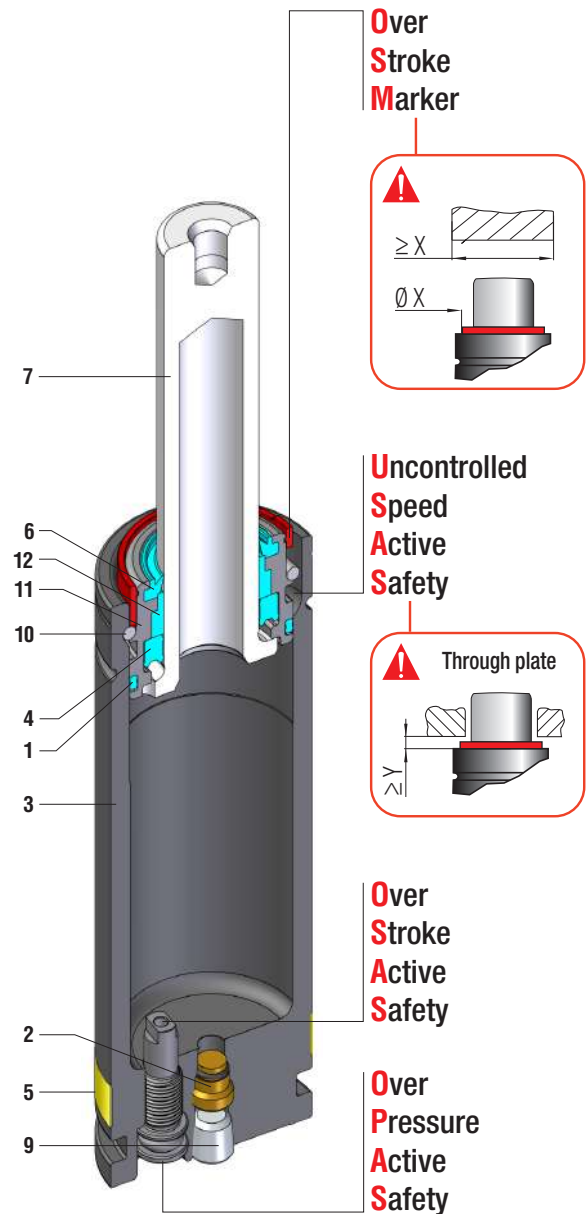

M 300

Mini cilindri - Mini cylinders - Mini Gasdruckfedern
 Mini-ressorts - Mini cilindros - Mini-cilindros

SEALING	ROD SEAL	
DESIGN	RETAINING GROOVE DESIGN	BUSH-BODY DESIGN (M 300 only)

1	Dual ring seal	5	Force color code	9	Stopper
2	Valve	6	Rod wiper	10	Retaining ring
3	Body	7	Rod (Nitrited Superfinished)	11	Bush
4	Rod seal	8	O-ring	12	Guide ring

RANGE CHART

Model	Body Ø		Stroke Cu		Initial force F0						
	mm	inch	mm	inch	daN	lb	OSAS	USAS	OPAS	SKUDO	SW
M 50	12	0.47	7 - 125	0.28 - 4.92	6 - 50	13 - 112	-	-	-	-	✓
M 50 TBI	5/8" 11 UNC		7 - 125	0.28 - 4.92	6 - 50	13 - 112	-	-	-	-	-
M 50 TBM1	M 16 X 1,5		7 - 125	0.28 - 4.92	6 - 50	13 - 112	-	-	-	-	-
M 50 TBM2	M 16 X 2		7 - 125	0.28 - 4.92	6 - 50	13 - 112	-	-	-	-	-
M 50 TEM	M 16 X 2		7 - 125	0.28 - 4.92	6 - 50	13 - 112	-	-	-	-	-
M 70	15	0.59	7 - 125	0.28 - 4.92	8 - 70	18 - 157	-	-	-	-	✓
M 90	19	0.75	7 - 125	0.28 - 4.92	5 - 90	11 - 202	✓	✓	✓	-	✓
M 90 TBM	M 24 X 1,5		7 - 125	0.28 - 4.92	5 - 90	11 - 202	✓	✓	✓	-	-
M 90 TEM	M 24 X 1,5		7 - 125	0.28 - 4.92	5 - 90	11 - 202	✓	✓	✓	-	-
M 90 TBI	1" 8 UNC		7 - 125	0.28 - 4.92	5 - 90	11 - 202	✓	✓	✓	-	-
M 200	25	0.98	7 - 200	0.28 - 7.87	17 - 200	38 - 450	✓	✓	✓	-	✓
M 300	32	1.26	7 - 125	0.28 - 4.92	80 - 320	180 - 719	✓	✓	✓	-	✓

✓ Built-in as standard

✓ Optional upon request

HOW TO ORDER

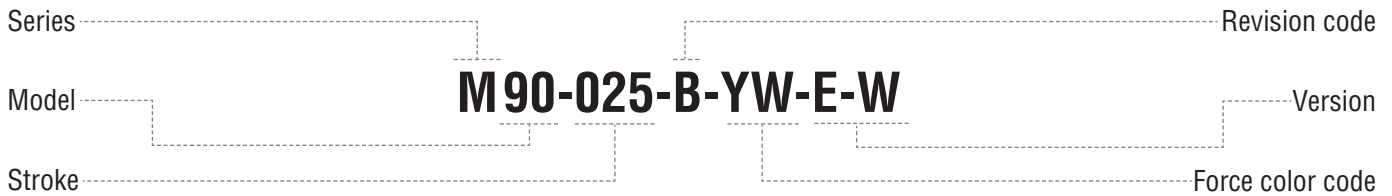

Available versions

M 90-025-B-YW	M 90-025-B-YW-W	M 90-025-B-E	M 90-025-B-E-W
Standard code	Add "-W" to standard code	Add "-E" to standard code	Add "-E-W" to standard code
Self contained	Self contained	Easy Manifold	Easy Manifold
	+ Secondary wiper		+ Secondary wiper



p. 262

ACTIVE SAFETY

* F_{1i} = Isothermal end force at 100% Cu p. 16
 ** F_{1p} = Polytrophic end force at 100% Cu

Force color code	P		F ₀	
	bar	psi	daN	lb
GR	45	653	13	29
BU	90	1305	25	56
RD	135	1958	38	85
YW	180	2610	50	112
BK	20-180	290-2610	6-50	13-112

Pressione da specificare in fase d'ordine.
 Pressure to be specified when ordering.
 Druck bei Bestellung anzugeben.
 Pression à préciser lors de la commande.
 La presión se debe especificar al realizar el pedido.
 Pressão a ser especificada no pedido.

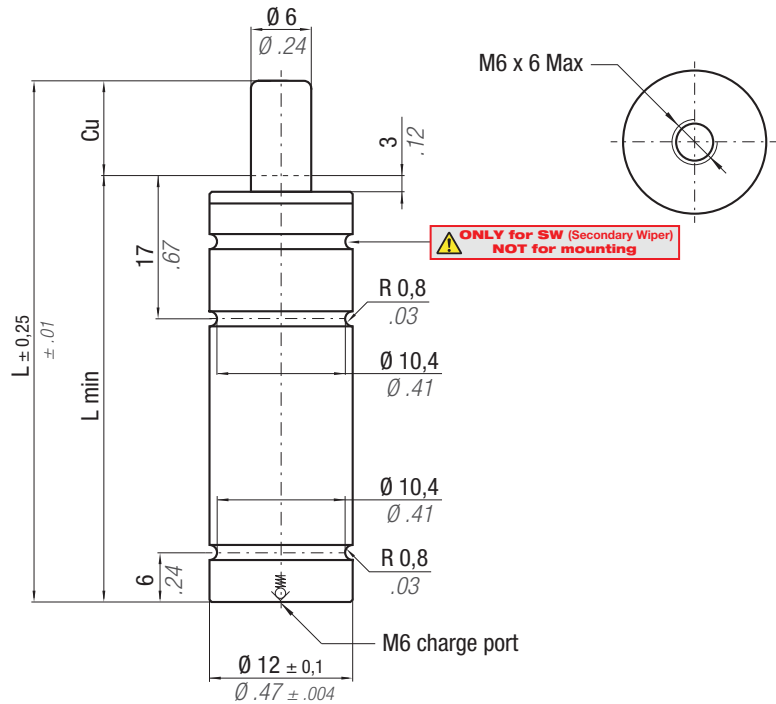

	0 - 80 °C 32 - 176 °F	ΔP $\pm 0,33 \%/^{\circ}C$	P max 180 bar 2610 psi	P min 20 bar 290 psi	S 0,28 cm ² 0,043 in ²	SPM ~ 100 - 150 (at 20°C)	Max Speed 1,8 m/s 70,8 in/s	Maintenance kit Disposable
--	--------------------------	---------------------------------------	------------------------------	----------------------------	----------------------------------------------------	---------------------------------	-----------------------------------	-------------------------------

CODE	Cu		L		L min		F _{1i} *		F _{1p} **		V ₀		PED		
	mm	inch	mm	inch	mm	inch	daN	lb	daN	lb	cm ³	in ³	~Kg	~lb	
M50 - 007 - A - ...	7	0.28	56	2.20	49	1.93	1,24 x F0		1,41 x F0		1,2	0.07	0,03	0.07	✓
M50 - 010 - A - ...	10	0.39	62	2.44	52	2.05	1,30 x F0		1,50 x F0		1,4	0.09	0,03	0.07	✓
M50 - 013 - A - ...	12,7	0.50	67,4	2.65	54,7	2.15	1,35 x F0		1,57 x F0		1,6	0.10	0,03	0.07	✓
M50 - 015 - A - ...	15	0.59	72	2.83	57	2.24	1,38 x F0		1,62 x F0		1,8	0.11	0,03	0.07	✓
M50 - 019 - A - ...	19	0.75	80	3.15	61	2.40	1,42 x F0		1,69 x F0		2,1	0.13	0,03	0.07	✓
M50 - 025 - A - ...	25	0.98	92	3.62	67	2.64	1,47 x F0		1,77 x F0		2,5	0.15	0,03	0.07	✓
M50 - 038 - A - ...	38	1.50	118	4.65	80	3.15	1,53 x F0		1,88 x F0		3,5	0.21	0,04	0.09	✓
M50 - 050 - A - ...	50	1.97	142	5.59	92	3.62	1,57 x F0		1,95 x F0		4,4	0.27	0,05	0.11	✓
M50 - 063 - A - ...	63,5	2.50	172	6.77	108,5	4.27	1,57 x F0		1,93 x F0		5,6	0.34	0,06	0.13	✓
M50 - 075 - A - ...	75	2.95	195	7.68	120	4.72	1,59 x F0		1,97 x F0		6,5	0.40	0,06	0.13	✓
M50 - 080 - A - ...	80	3.15	205	8.07	125	4.92	1,59 x F0		1,98 x F0		6,9	0.42	0,07	0.15	✓
M50 - 100 - A - ...	100	3.94	245	9.65	145	5.71	1,62 x F0		2,02 x F0		8,4	0.51	0,08	0.18	✓
M50 - 125 - A - ...	125	4.92	295	11.61	170	6.69	1,64 x F0		2,06 x F0		10,2	0.62	0,09	0.20	✓

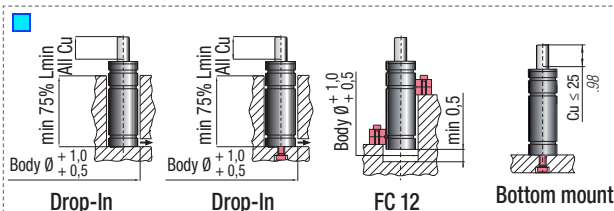

HOW TO ORDER

p. 39

INSTALLATION GUIDELINE

p. 205

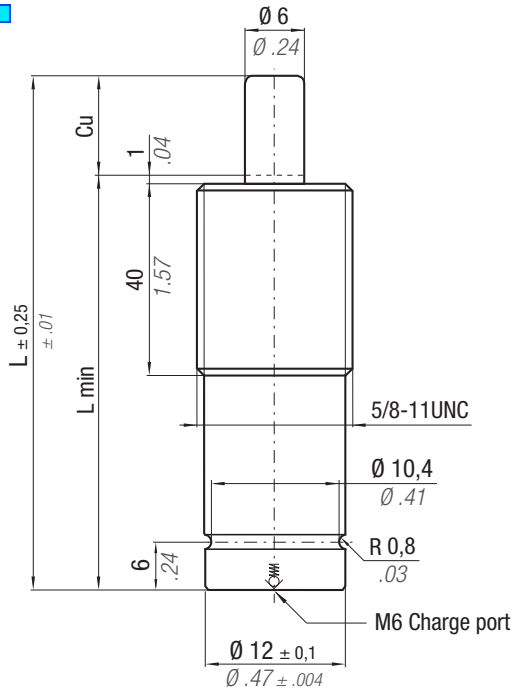

cod. 39CM02A
(optional)

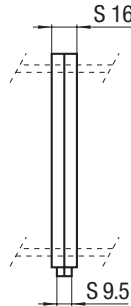

* $F_{1i} =$

Isothermal
end force
at 100% Cu



** $F_{1p} =$

Polytropic
end force
at 100% Cu



ACTIVE SAFETY

Force color code	P		F ₀	
	bar	psi	Initial force ± 5% at +20°C +68°F	
GR	45	653	13	29
BU	90	1305	25	56
RD	135	1958	38	85
YW	180	2610	50	112
BK	20-180	290-2610	6-50	13-112

Pressione da specificare in fase d'ordine.
Pressure to be specified when ordering.
Druck bei Bestellung anzugeben.
Pression à préciser lors de la commande.
La presión se debe especificar al realizar el pedido.
Pressão a ser especificada no pedido.

	0 - 80 °C 32 - 176 °F	ΔP ± 0,33 %/°C	P max 180 bar 2610 psi	P min 20 bar 290 psi	S 0,28 cm ² 0,043 in ²	SPM ~ 100 - 150 (at 20°C)	Max Speed 1,8 m/s 70.8 in/s	Maintenance kit Disposable
--	--------------------------	---------------------------	------------------------------	----------------------------	----------------------------------------------------	---------------------------------	-----------------------------------	-------------------------------

CODE	Cu		L		L min		F _{1i} *		F _{1p} **		V ₀		PED 2014/68/EU		
	mm	inch	mm	inch	mm	inch	daN	lb	daN	lb	cm ³	in ³		~Kg	~lb
M50 - 007 - A - ... - TBI	7	0.28	56	2.20	49	1.93	1,24 x F ₀		1,41 x F ₀		1,2	0.07	0,03	0.07	✓
M50 - 010 - A - ... - TBI	10	0.39	62	2.44	52	2.05	1,30 x F ₀		1,50 x F ₀		1,4	0.09	0,03	0.07	✓
M50 - 013 - A - ... - TBI	12,7	0.50	67,4	2.65	54,7	2.15	1,35 x F ₀		1,57 x F ₀		1,6	0.10	0,03	0.07	✓
M50 - 015 - A - ... - TBI	15	0.59	72	2.83	57	2.24	1,38 x F ₀		1,62 x F ₀		1,8	0.11	0,03	0.07	✓
M50 - 019 - A - ... - TBI	19	0.75	80	3.15	61	2.40	1,42 x F ₀		1,69 x F ₀		2,1	0.13	0,03	0.07	✓
M50 - 025 - A - ... - TBI	25	0.98	92	3.62	67	2.64	1,47 x F ₀		1,77 x F ₀		2,5	0.15	0,03	0.07	✓
M50 - 038 - A - ... - TBI	38	1.50	118	4.65	80	3.15	1,53 x F ₀		1,88 x F ₀		3,5	0.21	0,04	0.09	✓
M50 - 050 - A - ... - TBI	50	1.97	142	5.59	92	3.62	1,57 x F ₀		1,95 x F ₀		4,4	0.27	0,05	0.11	✓
M50 - 063 - A - ... - TBI	63,5	2.50	172	6.77	108,5	4.27	1,57 x F ₀		1,93 x F ₀		5,6	0.34	0,06	0.13	✓
M50 - 075 - A - ... - TBI	75	2.95	195	7.68	120	4.72	1,59 x F ₀		1,97 x F ₀		6,5	0.40	0,06	0.13	✓
M50 - 080 - A - ... - TBI	80	3.15	205	8.07	125	4.92	1,59 x F ₀		1,98 x F ₀		6,9	0.42	0,07	0.15	✓
M50 - 100 - A - ... - TBI	100	3.94	245	9.65	145	5.71	1,62 x F ₀		2,02 x F ₀		8,4	0.51	0,08	0.18	✓
M50 - 125 - A - ... - TBI	125	4.92	295	11.61	170	6.69	1,64 x F ₀		2,06 x F ₀		10,2	0.62	0,09	0.20	✓

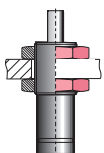

39DI5/8-11A

HOW TO ORDER

p. 39

INSTALLATION GUIDELINE

p. 205



ACTIVE SAFETY

* $F_{1i} =$

Isothermal end force at 100% Cu p. 16

** $F_{1p} =$

Polytropic end force at 100% Cu

Force color code	P		Fo Initial force $\pm 5\%$ at $+20^{\circ}\text{C} + 68^{\circ}\text{F}$	
	bar	psi	daN	lb
GR	45	653	13	29
BU	90	1305	25	56
RD	135	1958	38	85
YW	180	2610	50	112
BK	20-180	290-2610	6-50	13-112

Pressione da specificare in fase d'ordine.
Pressure to be specified when ordering.
Druck bei Bestellung anzugeben.
Pression à préciser lors de la commande.
La presión se debe especificar al realizar el pedido.
Pressão a ser especificada no pedido.

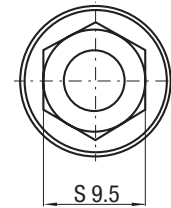
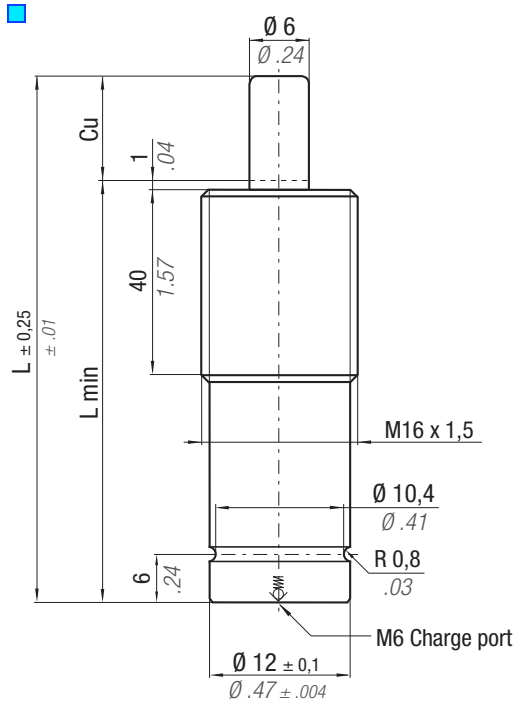

cod. 39CM02A (optional)

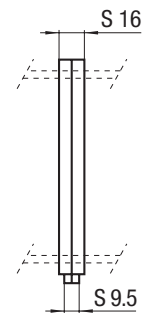

	0 - 80 °C 32 - 176 °F	ΔP $\pm 0,33\% / ^{\circ}\text{C}$	P max 180 bar 2610 psi	P min 20 bar 290 psi	S 0,28 cm ² 0,043 in ²	SPM ~ 100 - 150 (at 20°C)	Max Speed 1,8 m/s 70.8 in/s	Maintenance kit Disposable
--	--------------------------	-----------------------------------------------	------------------------------	----------------------------	----------------------------------------------------	---------------------------------	-----------------------------------	-------------------------------

CODE	Cu		L		L min		F _{1i} * End force *		F _{1p} ** End force **		Vo		PED 2014/68/EU		
	mm	inch	mm	inch	mm	inch	daN	lb	daN	lb	cm ³	in ³		~Kg	~lb
M50 - 007 - A - ... - TBM1	7	0.28	56	2.20	49	1.93	1,24 x F0		1,41 x F0		1,2	0.07	0,03	0.07	✓
M50 - 010 - A - ... - TBM1	10	0.39	62	2.44	52	2.05	1,30 x F0		1,50 x F0		1,4	0.09	0,03	0.07	✓
M50 - 013 - A - ... - TBM1	12,7	0.50	67,4	2.65	54,7	2.15	1,35 x F0		1,57 x F0		1,6	0.10	0,03	0.07	✓
M50 - 015 - A - ... - TBM1	15	0.59	72	2.83	57	2.24	1,38 x F0		1,62 x F0		1,8	0.11	0,03	0.07	✓
M50 - 019 - A - ... - TBM1	19	0.75	80	3.15	61	2.40	1,42 x F0		1,69 x F0		2,1	0.13	0,03	0.07	✓
M50 - 025 - A - ... - TBM1	25	0.98	92	3.62	67	2.64	1,47 x F0		1,77 x F0		2,5	0.15	0,03	0.07	✓
M50 - 038 - A - ... - TBM1	38	1.50	118	4.65	80	3.15	1,53 x F0		1,88 x F0		3,5	0.21	0,04	0.09	✓
M50 - 050 - A - ... - TBM1	50	1.97	142	5.59	92	3.62	1,57 x F0		1,95 x F0		4,4	0.27	0,05	0.11	✓
M50 - 063 - A - ... - TBM1	63,5	2.50	172	6.77	108,5	4.27	1,57 x F0		1,93 x F0		5,6	0.34	0,06	0.13	✓
M50 - 075 - A - ... - TBM1	75	2.95	195	7.68	120	4.72	1,59 x F0		1,97 x F0		6,5	0.40	0,06	0.13	✓
M50 - 080 - A - ... - TBM1	80	3.15	205	8.07	125	4.92	1,59 x F0		1,98 x F0		6,9	0.42	0,07	0.15	✓
M50 - 100 - A - ... - TBM1	100	3.94	245	9.65	145	5.71	1,62 x F0		2,02 x F0		8,4	0.51	0,08	0.18	✓
M50 - 125 - A - ... - TBM1	125	4.92	295	11.61	170	6.69	1,64 x F0		2,06 x F0		10,2	0.62	0,09	0.20	✓

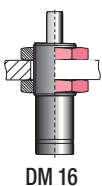

DM 16

HOW TO ORDER

p. 39

INSTALLATION GUIDELINE

p. 205

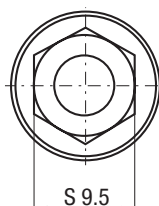
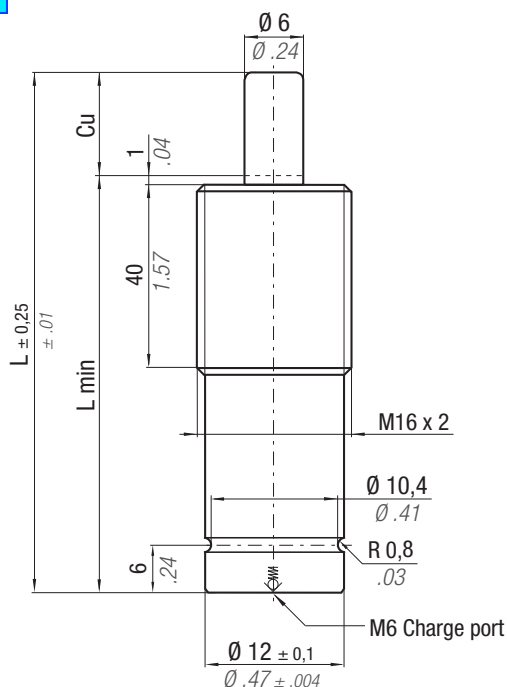

cod. 39CM02A
(optional)

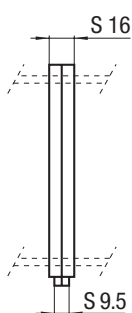

* $F_{1i} =$

Isothermal
end force at 100% Cu

👉 p. 16

** $F_{1p} =$

Polytrophic
end force at 100% Cu

👉

ACTIVE SAFETY

Force color code	P		F ₀	
	bar	psi	Initial force ± 5% at +20°C +68°F	
GR	45	653	13	29
BU	90	1305	25	56
RD	135	1958	38	85
YW	180	2610	50	112
BK	20-180	290-2610	6-50	13-112

Pressione da specificare in fase d'ordine.
Pressure to be specified when ordering.
Druck bei Bestellung anzugeben.
Pression à préciser lors de la commande.
La presión se debe especificar al realizar el pedido.
Pressão a ser especificada no pedido.

	0 - 80 °C 32 - 176 °F	ΔP ± 0,33 %/°C	P max 180 bar 2610 psi	P min 20 bar 290 psi	S 0,28 cm ² 0.043 in ²	SPM ~ 100 - 150 (at 20°C)	Max Speed 1,8 m/s 70.8 in/s	Maintenance kit Disposable
--	--------------------------	---------------------------	------------------------------	----------------------------	----------------------------------------------------	---------------------------------	-----------------------------------	-------------------------------

CODE	Cu		L		L min		F _{1i} *		F _{1p} **		V ₀		~Kg	~lb	PED 2014/68/EU
	mm	inch	mm	inch	mm	inch	daN	lb	daN	lb	cm ³	in ³			
M50 - 007 - A - ... - TBM2	7	0.28	56	2.20	49	1.93	1,24 x F ₀		1,41 x F ₀		1,2	0.07	0,03	0.07	✓
M50 - 010 - A - ... - TBM2	10	0.39	62	2.44	52	2.05	1,30 x F ₀		1,50 x F ₀		1,4	0.09	0,03	0.07	✓
M50 - 013 - A - ... - TBM2	12,7	0.50	67,4	2.65	54,7	2.15	1,35 x F ₀		1,57 x F ₀		1,6	0.10	0,03	0.07	✓
M50 - 015 - A - ... - TBM2	15	0.59	72	2.83	57	2.24	1,38 x F ₀		1,62 x F ₀		1,8	0.11	0,03	0.07	✓
M50 - 019 - A - ... - TBM2	19	0.75	80	3.15	61	2.40	1,42 x F ₀		1,69 x F ₀		2,1	0.13	0,03	0.07	✓
M50 - 025 - A - ... - TBM2	25	0.98	92	3.62	67	2.64	1,47 x F ₀		1,77 x F ₀		2,5	0.15	0,03	0.07	✓
M50 - 038 - A - ... - TBM2	38	1.50	118	4.65	80	3.15	1,53 x F ₀		1,88 x F ₀		3,5	0.21	0,04	0.09	✓
M50 - 050 - A - ... - TBM2	50	1.97	142	5.59	92	3.62	1,57 x F ₀		1,95 x F ₀		4,4	0.27	0,05	0.11	✓
M50 - 063 - A - ... - TBM2	63,5	2.50	172	6.77	108,5	4.27	1,57 x F ₀		1,93 x F ₀		5,6	0.34	0,06	0.13	✓
M50 - 075 - A - ... - TBM2	75	2.95	195	7.68	120	4.72	1,59 x F ₀		1,97 x F ₀		6,5	0.40	0,06	0.13	✓
M50 - 080 - A - ... - TBM2	80	3.15	205	8.07	125	4.92	1,59 x F ₀		1,98 x F ₀		6,9	0.42	0,07	0.15	✓
M50 - 100 - A - ... - TBM2	100	3.94	245	9.65	145	5.71	1,62 x F ₀		2,02 x F ₀		8,4	0.51	0,08	0.18	✓
M50 - 125 - A - ... - TBM2	125	4.92	295	11.61	170	6.69	1,64 x F ₀		2,06 x F ₀		10,2	0.62	0,09	0.20	✓

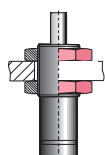

39DM16X2A

HOW TO ORDER

👉 p. 39

INSTALLATION GUIDELINE

👉 p. 205



ACTIVE SAFETY

* F_{1i} = Isothermal end force at 100% Cu p. 16

** F_{1p} = Polytrophic end force at 100% Cu

Force color code	P		F ₀ Initial force ± 5% at +20°C +68°F	
	bar	psi	daN	lb
GR	45	653	13	29
BU	90	1305	25	56
RD	135	1958	38	85
YW	180	2610	50	112
BK	20-180	290-2610	6-50	13-112

Pressione da specificare in fase d'ordine.
Pressure to be specified when ordering.
Druck bei Bestellung anzugeben.
Pression à préciser lors de la commande.
La presión se debe especificar al realizar el pedido.
Pressão a ser especificada no pedido.

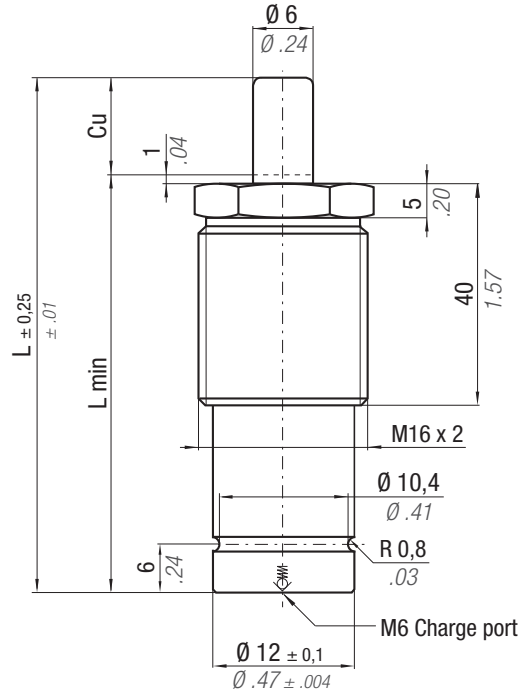

	0 - 80 °C 32 - 176 °F	ΔP ± 0,33 %/°C	P max 180 bar 2610 psi	P min 20 bar 290 psi	S 0,28 cm ² 0,043 in ²	SPM ~ 100 - 150 (at 20°C)	Max Speed 1,8 m/s 70.8 in/s	Maintenance kit Disposable
--	--------------------------	---------------------------	------------------------------	----------------------------	----------------------------------------------------	---------------------------------	-----------------------------------	-------------------------------

CODE	Cu		L		L min		F _{1i} * End force *		F _{1p} ** End force **		V ₀		PED 2014/68/EU		
	mm	inch	mm	inch	mm	inch	daN	lb	daN	lb	cm ³	in ³	~Kg	~lb	
M50 - 007 - A - ... - TEM	7	0.28	56	2.20	49	1.93	1,24 x F ₀		1,41 x F ₀		1,2	0.07	0,03	0.07	✓
M50 - 010 - A - ... - TEM	10	0.39	62	2.44	52	2.05	1,30 x F ₀		1,50 x F ₀		1,4	0.09	0,03	0.07	✓
M50 - 013 - A - ... - TEM	12,7	0.50	67,4	2.65	54,7	2.15	1,35 x F ₀		1,57 x F ₀		1,6	0.10	0,03	0.07	✓
M50 - 015 - A - ... - TEM	15	0.59	72	2.83	57	2.24	1,38 x F ₀		1,62 x F ₀		1,8	0.11	0,03	0.07	✓
M50 - 019 - A - ... - TEM	19	0.75	80	3.15	61	2.40	1,42 x F ₀		1,69 x F ₀		2,1	0.13	0,03	0.07	✓
M50 - 025 - A - ... - TEM	25	0.98	92	3.62	67	2.64	1,47 x F ₀		1,77 x F ₀		2,5	0.15	0,03	0.07	✓
M50 - 038 - A - ... - TEM	38	1.50	118	4.65	80	3.15	1,53 x F ₀		1,88 x F ₀		3,5	0.21	0,04	0.09	✓
M50 - 050 - A - ... - TEM	50	1.97	142	5.59	92	3.62	1,57 x F ₀		1,95 x F ₀		4,4	0.27	0,05	0.11	✓
M50 - 063 - A - ... - TEM	63,5	2.50	172	6.77	108,5	4.27	1,57 x F ₀		1,93 x F ₀		5,6	0.34	0,06	0.13	✓
M50 - 075 - A - ... - TEM	75	2.95	195	7.68	120	4.72	1,59 x F ₀		1,97 x F ₀		6,5	0.40	0,06	0.13	✓
M50 - 080 - A - ... - TEM	80	3.15	205	8.07	125	4.92	1,59 x F ₀		1,98 x F ₀		6,9	0.42	0,07	0.15	✓
M50 - 100 - A - ... - TEM	100	3.94	245	9.65	145	5.71	1,62 x F ₀		2,02 x F ₀		8,4	0.51	0,08	0.18	✓
M50 - 125 - A - ... - TEM	125	4.92	295	11.61	170	6.69	1,64 x F ₀		2,06 x F ₀		10,2	0.62	0,09	0.20	✓

HOW TO ORDER

p. 39

INSTALLATION GUIDELINE

p. 205

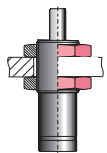

39DM16X2A

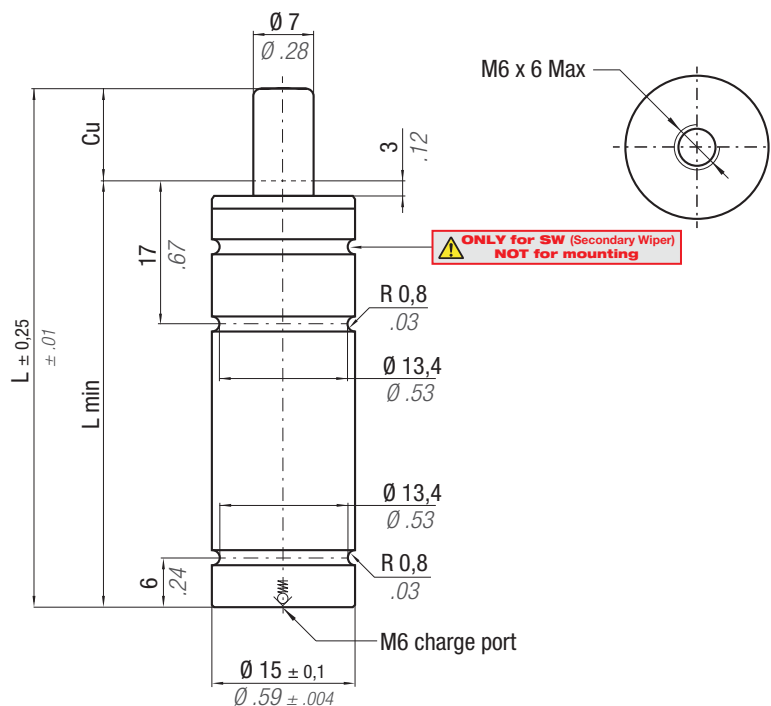

* $F_{1i} =$

Isothermal end force at 100% Cu



** $F_{1p} =$

Polytropic end force at 100% Cu

Force color code	P		Fo Initial force $\pm 5\%$ at $+20^\circ\text{C} / +68^\circ\text{F}$	
	bar	psi	daN	lb
GR	45	653	18	40
BU	90	1305	35	79
RD	135	1958	50	112
YW	180	2610	70	157
BK	20-180	290-2610	8-70	18-157

Pressione da specificare in fase d'ordine.
Pressure to be specified when ordering.
Druck bei Bestellung anzugeben.
Pression à préciser lors de la commande.
La presión se debe especificar al realizar el pedido.
Pressão a ser especificada no pedido.

ACTIVE SAFETY

	0 - 80 °C 32 - 176 °F	ΔP $\pm 0,33\% / ^\circ\text{C}$	P max 180 bar 2610 psi	P min 20 bar 290 psi	S 0,38 cm ² 0.059 in ²	SPM ~ 100 - 150 (at 20°C)	Max Speed 1,8 m/s 70.8 in/s	Maintenance kit Disposable
--	--------------------------	---------------------------------------------	-------------------------------------	-----------------------------------	-----------------------------------------------------------	----------------------------------------	------------------------------------------	--------------------------------------

CODE	Cu		L		L min		F_{1i} * End force		F_{1p} ** End force		Vo				
	mm	inch	mm	inch	mm	inch	daN	lb	daN	lb	cm ³	in ³		~Kg	~lb
M70 - 007 - A - ...	7	0.28	56	2.20	49	1.93	1,19 x F0		1,33 x F0		1,9	0.12	0,04	0.09	✓
M70 - 010 - A - ...	10	0.39	62	2.44	52	2.05	1,24 x F0		1,41 x F0		2,2	0.13	0,05	0.11	✓
M70 - 013 - A - ...	12,7	0.50	67,4	2.65	54,7	2.15	1,27 x F0		1,46 x F0		2,6	0.16	0,05	0.11	✓
M70 - 015 - A - ...	15	0.59	72	2.83	57	2.24	1,30 x F0		1,51 x F0		2,8	0.17	0,05	0.11	✓
M70 - 019 - A - ...	19	0.75	80	3.15	61	2.40	1,34 x F0		1,57 x F0		3,2	0.20	0,05	0.11	✓
M70 - 025 - A - ...	25	0.98	92	3.62	67	2.64	1,38 x F0		1,64 x F0		3,9	0.24	0,06	0.13	✓
M70 - 038 - A - ...	38	1.50	118	4.65	80	3.15	1,44 x F0		1,73 x F0		5,3	0.32	0,07	0.15	✓
M70 - 050 - A - ...	50	1.97	142	5.59	92	3.62	1,48 x F0		1,79 x F0		6,6	0.40	0,08	0.18	✓
M70 - 063 - A - ...	63,5	2.50	172	6.77	108,5	4.27	1,47 x F0		1,79 x F0		8,5	0.52	0,09	0.20	✓
M70 - 075 - A - ...	75	2.95	195	7.68	120	4.72	1,49 x F0		1,82 x F0		9,7	0.59	0,10	0.22	✓
M70 - 080 - A - ...	80	3.15	205	8.071	125	4.92	1,50 x F0		1,83 x F0		10,3	0.63	0,10	0.22	✓
M70 - 100 - A - ...	100	3.94	245	9.65	145	5.71	1,52 x F0		1,87 x F0		12,5	0.76	0,12	0.26	✓
M70 - 125 - A - ...	125	4.92	295	11.61	170	6.69	1,54 x F0		1,90 x F0		15,2	0.93	0,14	0.31	✓

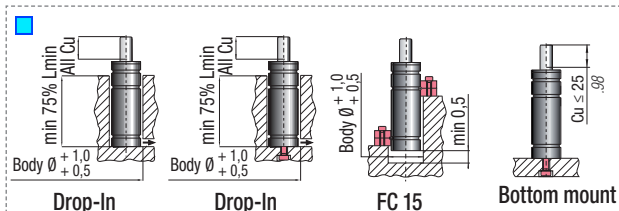

HOW TO ORDER

p. 39

INSTALLATION GUIDELINE

p. 205

ISO 11901 - 1 B8 3180 220 000 002(MB)	VDI 3003 - Blatt 2 39D 878 (VW)	B2 4007 (BMW)	075.90.50 (FCA)
------------------------------------------	------------------------------------	---------------	-----------------



ACTIVE SAFETY



Il nuovo codice sarà fornito solo ad esaurimento del vecchio - The new code will be supplied only when the old will be out of stock - Der neue Kode wird nur angegeben, wenn der alte nicht mehr lieferbar ist - Le nouveau code sera fourni uniquement lorsque le vieux stock sera écoulé - El nuevo código será suministrado sólo cuando se agoten las existencias del antiguo - O novo código irá ser fornecido apenas quando o antigo esgotar stock

easu MANIFOLD p. 247 p. 262

* F_{1i} = Isothermal end force at 100% Cu p. 16
 ** F_{1p} = Polytrophic end force at 100% Cu

Force color code	P		F ₀ Initial force ± 5% at +20°C +68°F	
	bar	psi	daN	lb
OR	10	145	5	11
PR	20	290	10	22
GR	60	870	30	67
BU	100	1450	50	112
RD	140	2030	70	157
YW	180	2610	90	202
BK	10-180	145-2610	5-90	11-202

Pressione da specificare in fase d'ordine.
 Pressure to be specified when ordering.
 Druck bei Bestellung anzugeben.
 Pression à préciser lors de la commande.
 La presión se debe especificar al realizar el pedido.
 Pressão a ser especificada no pedido.

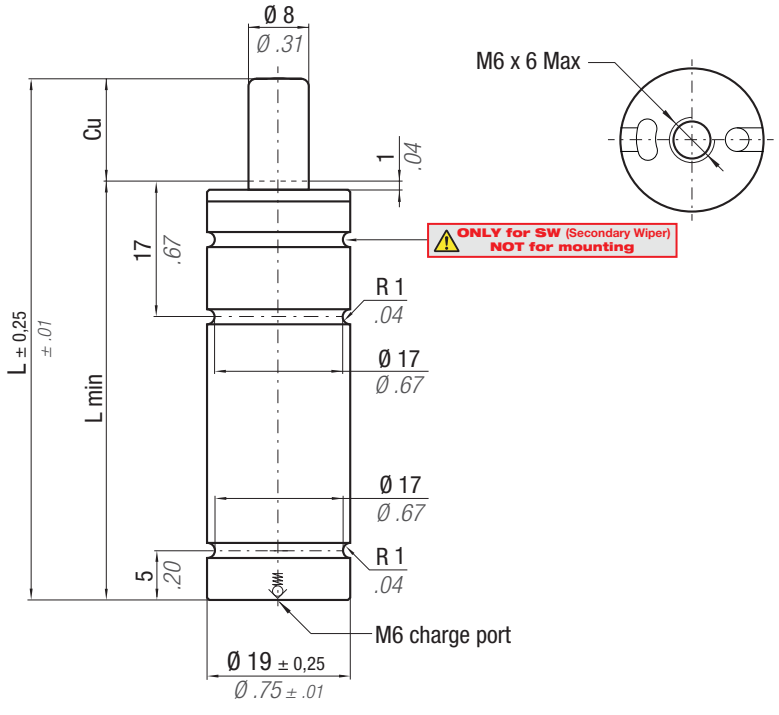

N₂	0 - 80 °C 32 - 176 °F	ΔP ± 0,33 %/°C	P max 180 bar 2610 psi	P min 10 bar 145 psi	S 0,50 cm ² 0,078 in ²	SPM ~ 100 - 150 (at 20°C)	Max Speed 1,8 m/s 70.8 in/s	Maintenance kit Disposable
----------------------	--------------------------	--------------------------	-------------------------------------	-----------------------------------	-----------------------------------------------------------	----------------------------------------	------------------------------------------	--------------------------------------

CODE PHASING OUT from 05/2019	NEW	C _u		L		L min		F _{1i} * End force *		F _{1p} ** End force **		V ₀		2014/68/EU
		mm	inch	mm	inch	mm	inch	daN	lb	daN	lb	cm ³	in ³	
M90 - 007 - A - ...	M90 - 007 - B - ...	7	0.28	56	2.20	49	1.93	1,21 x F ₀	1,39 x F ₀	2,3	0.14	0,07	0.15	✓
M90 - 010 - A - ...	M90 - 010 - B - ...	10	0.39	62	2.44	52	2.05	1,25 x F ₀	1,44 x F ₀	2,9	0.18	0,07	0.15	✓
M90 - 013 - A - ...	M90 - 013 - B - ...	12,7	0.50	67,4	2.65	54,7	2.15	1,27 x F ₀	1,48 x F ₀	3,4	0.21	0,08	0.18	✓
M90 - 015 - A - ...	M90 - 015 - B - ...	15	0.59	72	2.83	57	2.24	1,28 x F ₀	1,50 x F ₀	3,9	0.24	0,08	0.18	✓
M90 - 025 - A - ...	M90 - 025 - B - ...	25	0.98	92	3.62	67	2.64	1,32 x F ₀	1,57 x F ₀	5,8	0.35	0,09	0.20	✓
M90 - 038 - A - ...	M90 - 038 - B - ...	38,1	1.50	118,2	4.65	80,1	3.15	1,35 x F ₀	1,60 x F ₀	8,4	0.51	0,11	0.24	✓
M90 - 050 - A - ...	M90 - 050 - B - ...	50	1.97	142	5.59	92	3.62	1,36 x F ₀	1,62 x F ₀	10,8	0.66	0,12	0.26	✓
M90 - 063 - A - ...	M90 - 063 - B - ...	63,5	2.50	172	6.77	108,5	4.27	1,36 x F ₀	1,62 x F ₀	13,7	0.84	0,14	0.31	✓
M90 - 080 - A - ...	M90 - 080 - B - ...	80	3.15	205	8.07	125	4.92	1,37 x F ₀	1,64 x F ₀	17	1.04	0,15	0.33	✓
M90 - 100 - A - ...	M90 - 100 - B - ...	100	3.94	245	9.65	145	5.71	1,37 x F ₀	1,65 x F ₀	20,9	1.28	0,17	0.37	✓
M90 - 125 - A - ...	M90 - 125 - B - ...	125	4.92	295	11.61	170	6.69	1,38 x F ₀	1,66 x F ₀	25,8	1.57	0,20	0.44	✓

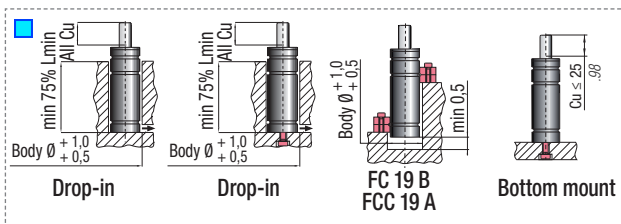

HOW TO ORDER p. 39

INSTALLATION GUIDELINE p. 205

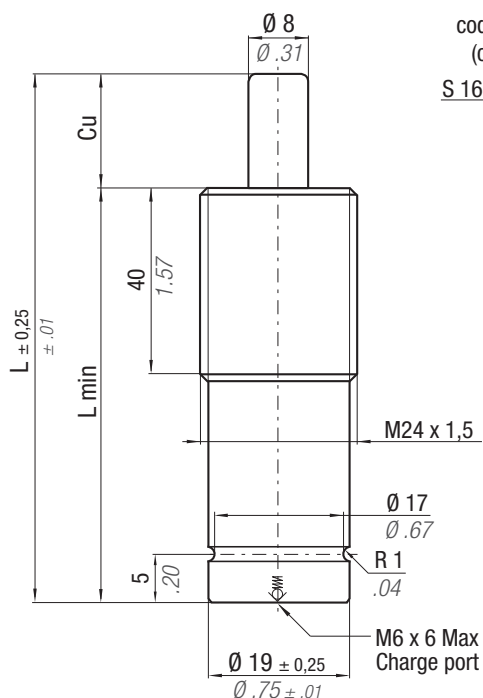

cod. 39 TBT (optional)

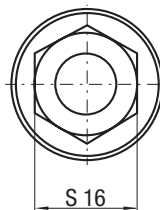
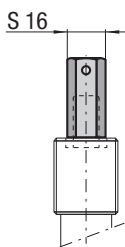

!
Senza riserva corsa
Without reserve of stroke
Ohne Hubreserve
Sans course de réserve
Sin margen de Carrera
Sem reserva de curso

!
NON superare 90% Cu
DO NOT exceed 90% Cu
NICHT überschreiten die 90% Cu
NE PAS dépasser 90% Cu
NO superar el 90% Cu
NÃO se excedam os 90% Cu

Il nuovo codice sarà fornito solo ad esaurimento del vecchio - The new code will be supplied only when the old will be out of stock - Der neue Kode wird nur angegeben, wenn der alte nicht mehr lieferbar ist - Le nouveau code sera fourni uniquement lorsque le vieux stock sera écoulé - El nuevo código será suministrado sólo cuando se agoten las existencias del antiguo - O novo código irá ser fornecido apenas quando o antigo esgotar stock



* F_{1i} =

Isothermal end force at 100% Cu p. 16

** F_{1p} =

Polytrophic end force at 100% Cu

Force color code	P		F ₀	
	bar	psi	Initial force ± 5% at +20°C +68°F	
OR	10	145	5	11
PR	20	290	10	22
GR	60	870	30	67
BU	100	1450	50	112
RD	140	2030	70	157
YW	180	2610	90	202
BK	10-180	145-2610	5-90	11-202

Pressione da specificare in fase d'ordine.
Pressure to be specified when ordering.
Druck bei Bestellung anzugeben.
Pression à préciser lors de la commande.
La presión se debe especificar al realizar el pedido.
Pressão a ser especificada no pedido.

ACTIVE SAFETY



OSAS



USAS



OPAS

M

N ₂		0 - 80 °C 32 - 176 °F	ΔP ± 0,33 %/°C	P max 180 bar 2610 psi	P min 10 bar 145 psi	S 0,50 cm ² 0,078 in ²	SPM ~ 100 - 150 (at 20°C)	Max Speed 1,8 m/s 70.8 in/s	Maintenance kit Disposable			
CODE	NEW	Cu	L	L min	F _{1i} *	F _{1p} **	V ₀	PED 2014/68/EU				
PHASING OUT from 05/2019		mm	inch	mm	inch	mm	inch	cm ³	in ³	~Kg	~lb	✓
M90-007-A-...-TBM	M90-007-B-...-TBM	7	0.28	56	2.20	49	1.93	2,3	0.14	0,07	0.15	✓
M90-010-A-...-TBM	M90-010-B-...-TBM	10	0.39	62	2.44	52	2.05	2,9	0.18	0,07	0.15	✓
M90-013-A-...-TBM	M90-013-B-...-TBM	12,7	0.50	67,4	2.65	54,7	2.15	3,4	0.21	0,08	0.18	✓
M90-015-A-...-TBM	M90-015-B-...-TBM	15	0.59	72	2.83	57	2.24	3,9	0.24	0,08	0.18	✓
M90-025-A-...-TBM	M90-025-B-...-TBM	25	0.98	92	3.62	67	2.64	5,8	0.35	0,09	0.20	✓
M90-038-A-...-TBM	M90-038-B-...-TBM	38,1	1.50	118,2	4.65	80,1	3.15	8,4	0.51	0,11	0.24	✓
M90-050-A-...-TBM	M90-050-B-...-TBM	50	1.97	142	5.59	92	3.62	10,8	0.66	0,12	0.26	✓
M90-063-A-...-TBM	M90-063-B-...-TBM	63,5	2.50	172	6.77	108,5	4.27	13,7	0.84	0,14	0.31	✓
M90-080-A-...-TBM	M90-080-B-...-TBM	80	3.15	205	8.07	125	4.92	17	1.04	0,15	0.33	✓
M90-100-A-...-TBM	M90-100-B-...-TBM	100	3.94	245	9.65	145	5.71	20,9	1.28	0,17	0.37	✓
M90-125-A-...-TBM	M90-125-B-...-TBM	125	4.92	295	11.61	170	6.69	25,8	1.57	0,20	0.44	✓

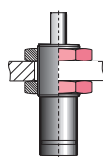

DM 24

HOW TO ORDER

p. 39

INSTALLATION GUIDELINE

p. 205

Il nuovo codice sarà fornito solo ad esaurimento del vecchio - The new code will be supplied only when the old will be out of stock - Der neue Kode wird nur angegeben, wenn der alte nicht mehr lieferbar ist - Le nouveau code sera fourni uniquement lorsque le vieux stock sera écoulé - El nuevo código será suministrado sólo cuando se agoten las existencias del antiguo - O novo código irá ser fornecido apenas quando o antigo esgotar stock

ACTIVE SAFETY



OSAS



USAS



OPAS



p. 262

* $F_{1i} =$

Isothermal end force at 100% Cu p. 16

** $F_{1p} =$

Polytropic end force at 100% Cu

Force color code	P		F ₀	
	bar	psi	daN	lb
OR	10	145	5	11
PR	20	290	10	22
GR	60	870	30	67
BU	100	1450	50	112
RD	140	2030	70	157
YW	180	2610	90	202
BK	10-180	145-2610	5-90	11-202

Pressione da specificare in fase d'ordine.
Pressure to be specified when ordering.
Druck bei Bestellung anzugeben.
Pression à préciser lors de la commande.
La presión se debe especificar al realizar el pedido.
Pressão a ser especificada no pedido.

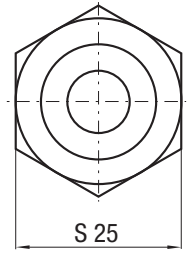
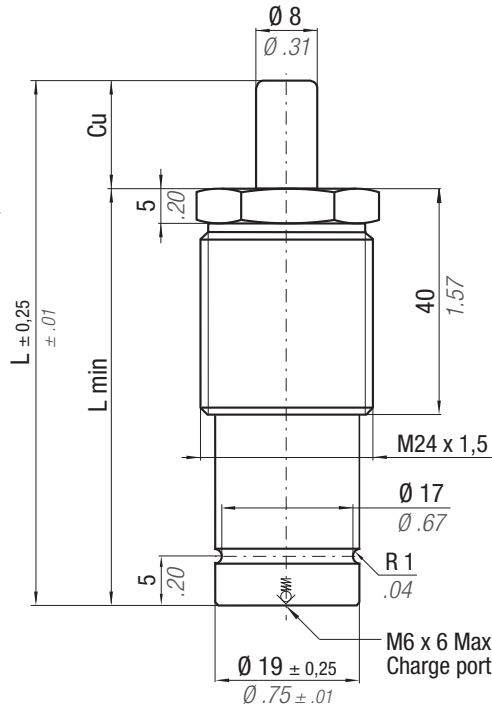

Senza riserva corsa
Without reserve of stroke
Ohne Hubreserve
Sans course de réserve
Sin margen de Carrera
Sem reserva de curso



NON superare 90% Cu
DO NOT exceed 90% Cu
NICHT überschreiten die 90% Cu
NE PAS dépasser 90% Cu
NO superar el 90% Cu
NÃO se excedam os 90% Cu

N ₂		0 - 80 °C 32 - 176 °F	ΔP ± 0,33 %/°C	P max 180 bar 2610 psi	P min 10 bar 145 psi	S 0,50 cm ² 0,078 in ²	SPM ~ 100 - 150 (at 20°C)	Max Speed 1,8 m/s 70.8 in/s	Maintenance kit Disposable
CODE PHASING OUT from 05/2019	NEW	Cu	L	L min	F _{1i} *	F _{1p} **	V ₀		
		mm	inch	mm	inch	mm	inch	cm ³	in ³
M90-007-A-...-TEM	M90-007-B-...-TEM	7	0.28	56	2.20	49	1.93	2,3	0.14
M90-010-A-...-TEM	M90-010-B-...-TEM	10	0.39	62	2.44	52	2.05	2,9	0.18
M90-013-A-...-TEM	M90-013-B-...-TEM	12,7	0.50	67,4	2.65	54,7	2.15	3,4	0.21
M90-015-A-...-TEM	M90-015-B-...-TEM	15	0.59	72	2.83	57	2.24	3,9	0.24
M90-025-A-...-TEM	M90-025-B-...-TEM	25	0.98	92	3.62	67	2.64	5,8	0.35
M90-038-A-...-TEM	M90-038-B-...-TEM	38,1	1.50	118,2	4.65	80,1	3.15	8,4	0.51
M90-050-A-...-TEM	M90-050-B-...-TEM	50	1.97	142	5.59	92	3.62	10,8	0.66
M90-063-A-...-TEM	M90-063-B-...-TEM	63,5	2.50	172	6.77	108,5	4.27	13,7	0.84
M90-080-A-...-TEM	M90-080-B-...-TEM	80	3.15	205	8.07	125	4.92	17	1.04
M90-100-A-...-TEM	M90-100-B-...-TEM	100	3.94	245	9.65	145	5.71	20,9	1.28
M90-125-A-...-TEM	M90-125-B-...-TEM	125	4.92	295	11.61	170	6.69	25,8	1.57

HOW TO ORDER

p. 39

INSTALLATION GUIDELINE

p. 205

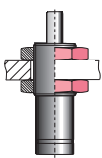

DM 24

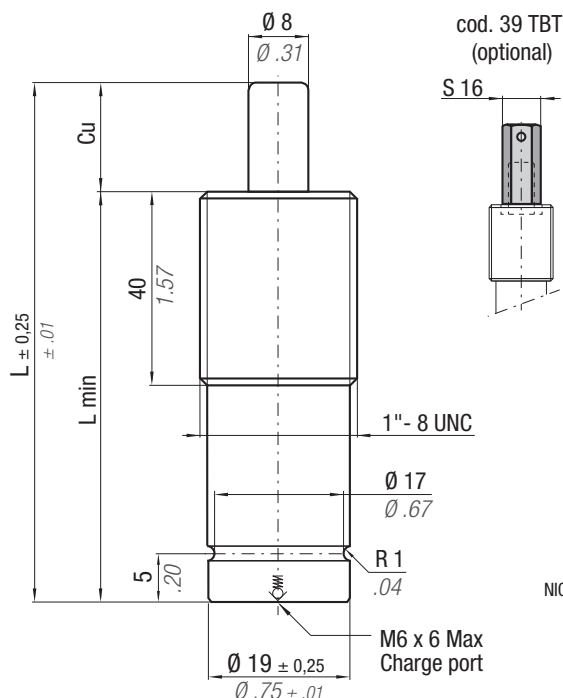

Senza riserva corsa
Without reserve of stroke
Ohne Hubreserve
Sans course de réserve
Sin margen de Carrera
Sem reserva de curso

NON superare 90% Cu
DO NOT exceed 90% Cu
NICHT überschreiten die 90% Cu
NE PAS dépasser 90% Cu
NO superar el 90% Cu
NÃO se excedam os 90% Cu

Il nuovo codice sarà fornito solo ad esaurimento del vecchio - The new code will be supplied only when the old will be out of stock - Der neue Kode wird nur angegeben, wenn der alte nicht mehr lieferbar ist - Le nouveau code sera fourni uniquement lorsque le vieux stock sera écoulé - El nuevo código será suministrado sólo cuando se agoten las existencias del antiguo - O novo código irá ser fornecido apenas quando o antigo esgotar stock



* F_{1i} = Isothermal end force at 100% Cu p. 16
 ** F_{1p} = Polytrophic end force at 100% Cu

Force color code	P		F ₀	
	bar	psi	Initial force ± 5% at +20°C +68°F	
OR	10	145	5	11
PR	20	290	10	22
GR	60	870	30	67
BU	100	1450	50	112
RD	140	2030	70	157
YW	180	2610	90	202
BK	10-180	145-2610	5-90	11-202

Pressione da specificare in fase d'ordine.
Pressure to be specified when ordering.
Druck bei Bestellung anzugeben.
Pression à préciser lors de la commande.
La presión se debe especificar al realizar el pedido.
Pressão a ser especificada no pedido.

ACTIVE SAFETY



N ₂		0 - 80 °C 32 - 176 °F	ΔP ± 0,33 %/°C	P max 180 bar 2610 psi	P min 10 bar 145 psi	S 0,50 cm ² 0.078 in ²	SPM ~ 100 - 150 (at 20°C)	Max Speed 1,8 m/s 70.8 in/s	Maintenance kit Disposable
CODE	NEW	Cu	L	L min	F _{1i} *	F _{1p} **	V ₀	PED 2014/68/EU	
PHASING OUT from 05/2019		mm inch	mm inch	mm inch	daN lb	daN lb	cm ³ in ³	~Kg ~lb	✓
M90-007-A-...-TBI	M90-007-B-...-TBI	7 0.28	56 2.20	49 1.93	1,21 x F ₀	1,39 x F ₀	2,3 0.14	0,07 0.15	✓
M90-010-A-...-TBI	M90-010-B-...-TBI	10 0.39	62 2.44	52 2.05	1,25 x F ₀	1,44 x F ₀	2,9 0.18	0,07 0.15	✓
M90-013-A-...-TBI	M90-013-B-...-TBI	12,7 0.50	67,4 2.65	54,7 2.15	1,27 x F ₀	1,48 x F ₀	3,4 0.21	0,08 0.18	✓
M90-015-A-...-TBI	M90-015-B-...-TBI	15 0.59	72 2.83	57 2.24	1,28 x F ₀	1,50 x F ₀	3,9 0.24	0,08 0.18	✓
M90-025-A-...-TBI	M90-025-B-...-TBI	25 0.98	92 3.62	67 2.64	1,32 x F ₀	1,57 x F ₀	5,8 0.35	0,09 0.20	✓
M90-038-A-...-TBI	M90-038-B-...-TBI	38,1 1.50	118,2 4.65	80,1 3.15	1,35 x F ₀	1,60 x F ₀	8,4 0.51	0,11 0.24	✓
M90-050-A-...-TBI	M90-050-B-...-TBI	50 1.97	142 5.59	92 3.62	1,36 x F ₀	1,62 x F ₀	10,8 0.66	0,12 0.26	✓
M90-063-A-...-TBI	M90-063-B-...-TBI	63,5 2.50	172 6.77	108,5 4.27	1,36 x F ₀	1,62 x F ₀	13,7 0.84	0,14 0.31	✓
M90-080-A-...-TBI	M90-080-B-...-TBI	80 3.15	205 8.07	125 4.92	1,37 x F ₀	1,64 x F ₀	17 1.04	0,15 0.33	✓
M90-100-A-...-TBI	M90-100-B-...-TBI	100 3.94	245 9.65	145 5.71	1,37 x F ₀	1,65 x F ₀	20,9 1.28	0,17 0.37	✓
M90-125-A-...-TBI	M90-125-B-...-TBI	125 4.92	295 11.61	170 6.69	1,38 x F ₀	1,66 x F ₀	25,8 1.57	0,20 0.44	✓

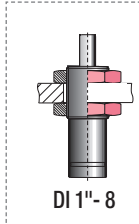

HOW TO ORDER

p. 39

INSTALLATION GUIDELINE

p. 205

ISO 11901 - 1 B8 3180 220 000 002(MB)	VDI 3003 - Blatt 2 K32D2-2400-50 (Nissan)	B2 4007 (BMW) E24.54.815.G (PSA)	075.90.50 (FCA) 39D 878 (VW)
------------------------------------------	----------------------------------------------	-------------------------------------	---------------------------------



SW

ACTIVE SAFETY



OSAS



USAS



OPAS

Il nuovo codice sarà fornito solo ad esaurimento del vecchio - The new code will be supplied only when the old will be out of stock - Der neue Kode wird nur angegeben, wenn der alte nicht mehr lieferbar ist - Le nouveau code sera fourni uniquement lorsque le vieux stock sera écoulé - El nuevo código será suministrado sólo cuando se agoten las existencias del antiguo - O novo código irá ser fornecido apenas quando o antigo esgotar stock



p. 262

* F_{1i} =

Isothermal end force at 100% Cu

** F_{1p} =

Polytropic end force at 100% Cu

Force color code	P		F ₀	
	bar	psi	daN	lb
OR	15	218	17	38
PR	25	363	28	63
GR	45	653	50	112
BU	90	1305	100	225
RD	135	1958	150	337
YW	180	2610	200	450
BK	10-180	145-2610	11-200	25-450

Pressione da specificare in fase d'ordine.
Pressure to be specified when ordering.
Druck bei Bestellung anzugeben.
Pression à préciser lors de la commande.
La presión se debe especificar al realizar el pedido.
Pressão a ser especificada no pedido.

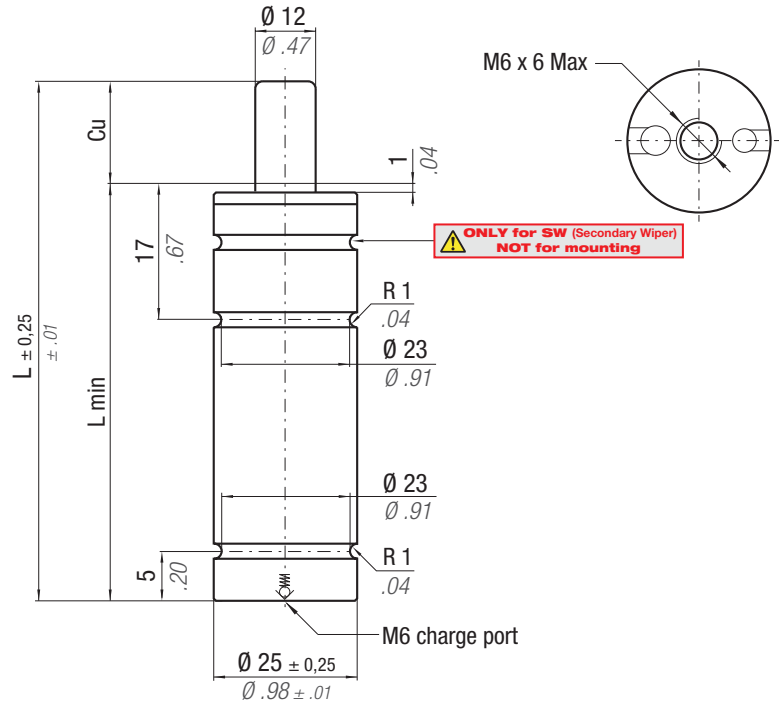

N ₂	0 - 80 °C 32 - 176 °F	ΔP ± 0,33 %/°C	P max 180 bar 2610 psi	P min 10 bar 145 psi	S 1,13 cm ² 0,175 in ²	SPM ~ 50 - 80 (at 20°C)	Max Speed 1,8 m/s 70,8 in/s	Maintenance kit Disposable
----------------	--------------------------	---------------------------	------------------------------	----------------------------	----------------------------------------------------	-------------------------------	-----------------------------------	-------------------------------

CODE PHASING OUT from 05/2019	NEW	Cu		L		L min		F _{1i} *		F _{1p} **		Vo		PED 2014/68/EU
		mm	inch	mm	inch	mm	inch	daN	lb	daN	lb	cm ³	in ³	
M200 - 007 - A - ...	M200 - 007 - B - ...	7	0.28	56	2.20	49	1.93	1,30 x F0	1,50 x F0	4	0.24	0,12	0.26	✓
M200 - 010 - A - ...	M200 - 010 - B - ...	10	0.39	62	2.44	52	2.05	1,34 x F0	1,57 x F0	5,2	0.32	0,13	0.29	✓
M200 - 013 - A - ...	M200 - 013 - B - ...	12,7	0.50	67,4	2.65	54,7	2.15	1,37 x F0	1,62 x F0	6,2	0.38	0,13	0.29	✓
M200 - 015 - A - ...	M200 - 015 - B - ...	15	0.59	72	2.83	57	2.24	1,38 x F0	1,64 x F0	7	0.43	0,14	0.31	✓
M200 - 016 - A - ...	M200 - 016 - B - ...	16	0.63	74	2.91	58	2.28	1,39 x F0	1,65 x F0	7,4	0.45	0,14	0.31	✓
M200 - 025 - A - ...	M200 - 025 - B - ...	25	0.98	92	3.62	67	2.64	1,43 x F0	1,72 x F0	10,8	0.66	0,16	0.35	✓
M200 - 038 - A - ...	M200 - 038 - B - ...	38,1	1.50	118,2	4.65	80,1	3.15	1,46 x F0	1,77 x F0	15,7	0.96	0,19	0.42	✓
M200 - 050 - A - ...	M200 - 050 - B - ...	50	1.97	142	5.59	92	3.62	1,47 x F0	1,79 x F0	20,2	1.23	0,20	0.44	✓
M200 - 063 - A - ...	M200 - 063 - B - ...	63,5	2.50	172	6.77	108,5	4.27	1,48 x F0	1,81 x F0	25,2	1.54	0,23	0.51	✓
M200 - 080 - A - ...	M200 - 080 - B - ...	80	3.15	205	8.07	125	4.92	1,49 x F0	1,83 x F0	31,2	1.90	0,26	0.57	✓
M200 - 100 - A - ...	M200 - 100 - B - ...	100	3.94	245	9.65	145	5.71	1,50 x F0	1,83 x F0	38,7	2.36	0,30	0.66	✓
M200 - 125 - A - ...	M200 - 125 - B - ...	125	4.92	295	11.61	170	6.69	1,50 x F0	1,84 x F0	48,1	2.94	0,34	0.75	✓
-	M200 - 150 - B - ...	150	5.91	353	13.90	203	7.99	1,57 x F0	1,81 x F0	59	2.32	0,42	0.93	✓
-	M200 - 160 - B - ...	160	6.30	373	14.69	213	8.39	1,57 x F0	1,81 x F0	62,8	2.47	0,45	0.99	✓
-	M200 - 175 - B - ...	175	6.89	403	15.87	228	8.98	1,57 x F0	1,82 x F0	68,4	2.69	0,47	1.04	✓
-	M200 - 200 - B - ...	200	7.87	453	17.83	253	9.96	1,58 x F0	1,83 x F0	77,8	3.06	0,52	1.15	✓

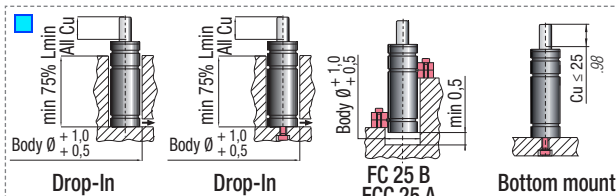

HOW TO ORDER

p. 39

INSTALLATION GUIDELINE

p. 205

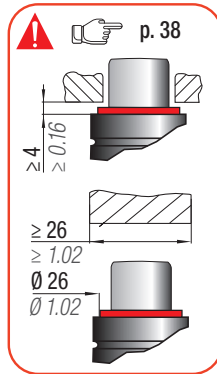
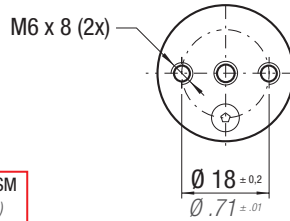
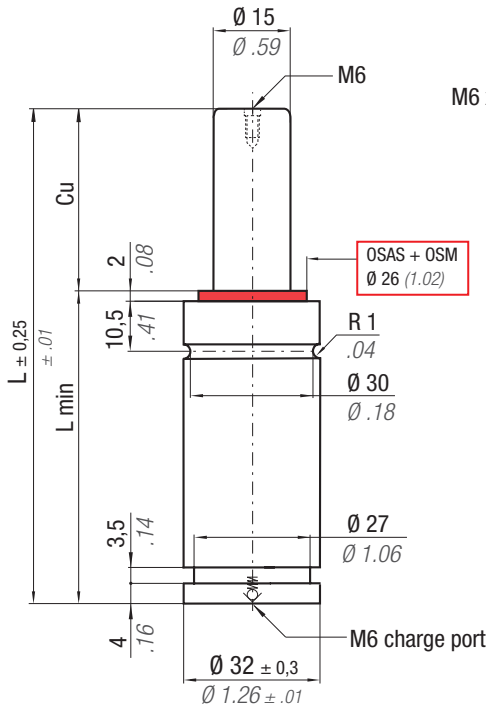

OSAS + OSM = OVER STROKE ACTIVE SAFETY + OVER STROKE MARKER



p. 262

* $F_{1i} =$

Isothermal end force at 100% Cu p. 16

** $F_{1p} =$

Polytrophic end force at 100% Cu

ACTIVE SAFETY



Force color code	P		Fo	
	bar	psi	daN	lb
GR	45	653	80	180
BU	90	1305	160	360
RD	135	1958	240	540
YW	180	2610	320	719
BK	10-180	145-2610	18-320	40-719

Initial force $\pm 5\%$ at $+20^\circ\text{C} + 68^\circ\text{F}$
 Pressione da specificare in fase d'ordine.
 Pressure to be specified when ordering.
 Druck bei Bestellung anzugeben.
 Pression à préciser lors de la commande.
 La presión se debe especificar al realizar el pedido.
 Pressão a ser especificada no pedido.

	0 - 80 °C 32 - 176 °F	ΔP $\pm 0,33\% / ^\circ\text{C}$	P max 180 bar 2610 psi	P min 10 bar 145 psi	S 1,77 cm ² 0.274 in ²	SPM ~ 50 - 80 (at 20°C)	Max Speed 1,8 m/s 70.8 in/s	Maintenance kit 39BMMCI32A
--	--------------------------	---------------------------------------------	-------------------------------------	-----------------------------------	-----------------------------------------------------------	--------------------------------------	------------------------------------------	--------------------------------------

CODE PHASING OUT from 04/2021	NEW	Cu		L		L min		F _{1i} *		F _{1p} **		V ₀		PED		
		mm	inch	mm	inch	mm	inch	daN	lb	daN	lb	cm ³	in ³	~Kg	~lb	2014/68/EU
M300-007-A-...	◆M300-007-B-...	7	0.28	56	2.20	49	1.93	1,20 x F ₀		1,35 x F ₀		8,3	0.51	0,21	0.01	✓
M300-010-A-...	◆M300-010-B-...	10	0.39	62	2.44	52	2.05	1,24 x F ₀		1,41 x F ₀		10,1	0.62	0,22	0.01	✓
M300-013-A-...	M300-013-B-...	12,7	0.50	67,4	2.65	54,7	2.15	1,27 x F ₀		1,46 x F ₀		11,7	0.71	0,23	0.01	✓
M300-015-A-...	M300-015-B-...	15	0.59	72	2.83	57	2.24	1,29 x F ₀		1,49 x F ₀		13,1	0.80	0,24	0.01	✓
M300-025-A-...	M300-025-B-...	25	0.98	92	3.62	67	2.64	1,35 x F ₀		1,58 x F ₀		19,1	1.17	0,26	0.01	✓
M300-038-A-...	M300-038-B-...	38	1.50	118	4.65	80	3.15	1,38 x F ₀		1,64 x F ₀		26,9	1.64	0,30	0.01	✓
M300-050-A-...	M300-050-B-...	50	1.97	142	5.59	92	3.62	1,40 x F ₀		1,67 x F ₀		34,1	2.08	0,34	0.01	✓
M300-063-A-...	M300-063-B-...	63,5	2.50	172	6.77	108,5	4.27	1,40 x F ₀		1,66 x F ₀		43,8	2.67	0,39	0.02	✓
M300-080-A-...	M300-080-B-...	80	3.15	205	8.07	125	4.92	1,41 x F ₀		1,69 x F ₀		53,7	3.28	0,44	0.02	✓
M300-100-A-...	M300-100-B-...	100	3.94	245	9.65	145	5.71	1,43 x F ₀		1,71 x F ₀		65,8	4.02	0,50	0.02	✓
M300-125-A-...	M300-125-B-...	125	4.92	295	11.61	170	6.69	1,44 x F ₀		1,73 x F ₀		80,8	4.93	0,57	0.02	✓

◆ Disposable

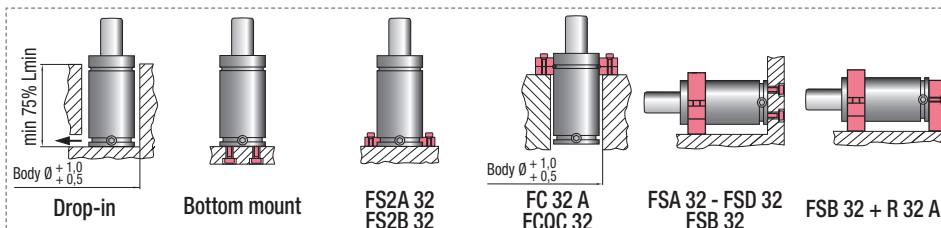

HOW TO ORDER

p. 39

INSTALLATION GUIDELINE

p. 205

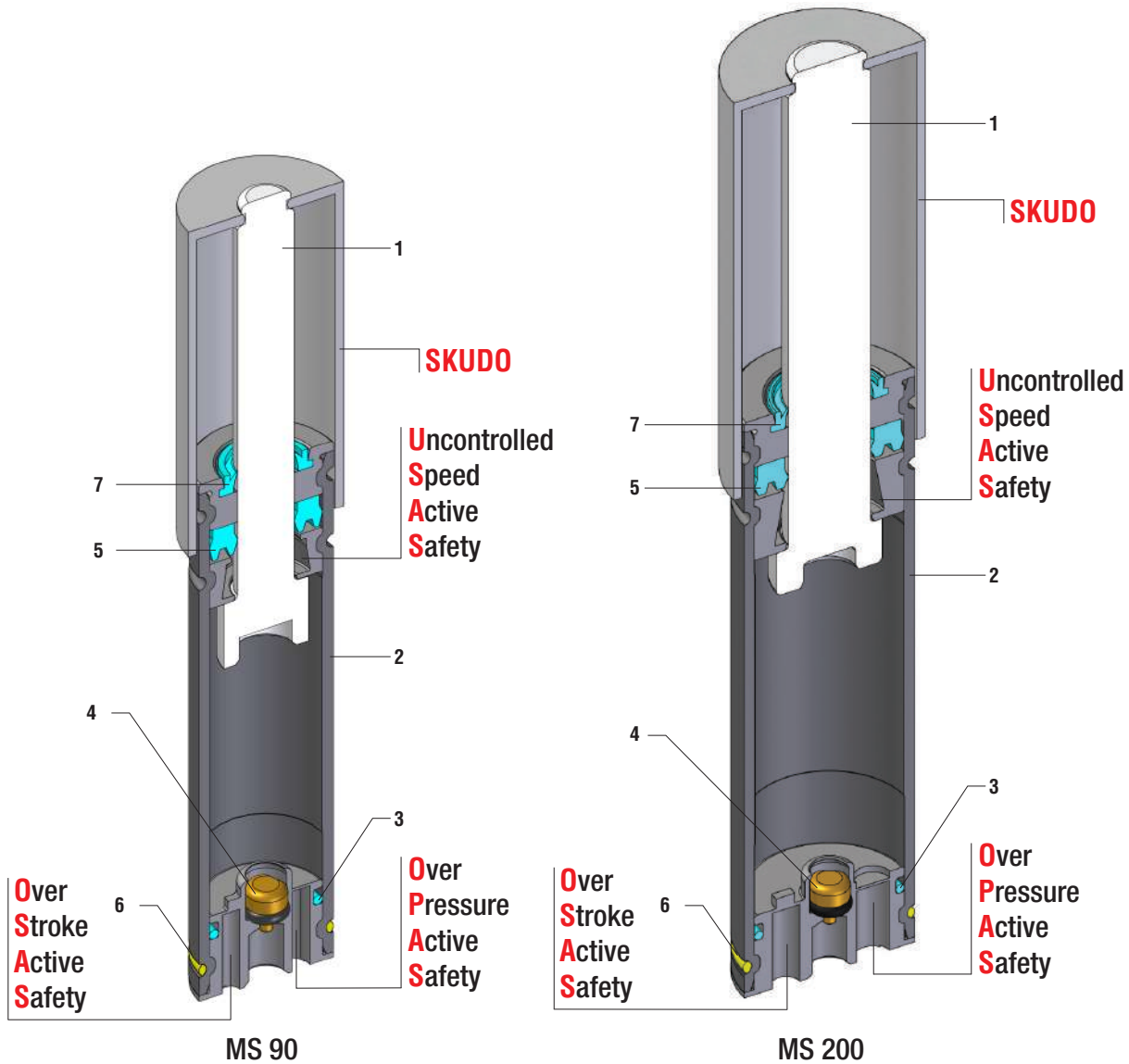

Mini cilindri - Mini cylinders - Mini Gasdruckfedern
 Mini-ressorts - Mini cilindros - Mini-cilindros

SEALING	ROD SEAL
DESIGN	RETAINING GROOVE DESIGN

1	Rod (nitrited superfinished)	5	Rod seal
2	Body	6	Force color code
3	O-ring	7	Rod wiper
4	Valve		

RANGE CHART

Model	Body Ø		Stroke Cu		Initial force F0		OSAS	USAS	OPAS	SKUDO
	mm	inch	mm	inch	daN	lb				
MS 90	19	0.75	7 - 122	0.28 - 4.80	5 - 90	11 - 202	✓	✓	✓	✓
MS 200	25	0.98	7 - 122	0.28 - 4.80	17 - 200	38 - 450	✓	✓	✓	✓

MS



HOW TO ORDER

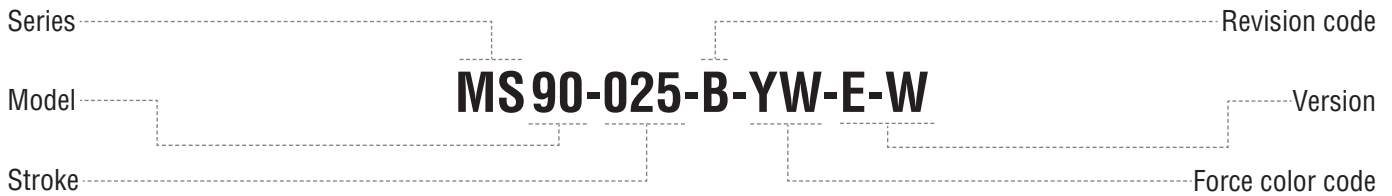

Available versions



MS 90-025-B-YW
Standard code



MS 90-025-B-YW-W
Add "-W" to standard code

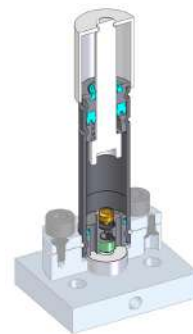
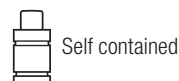

MS 90-025-B-E
Add "-E" to standard code

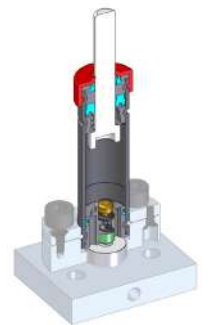

MS 90-025-B-E-W
Add "-E-W" to standard code

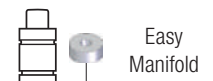

Il nuovo codice sarà fornito solo ad esaurimento del vecchio - The new code will be supplied only when the old will be out of stock - Der neue Kode wird nur angegeben, wenn der alte nicht mehr lieferbar ist - Le nouveau code sera fourni uniquement lorsque le vieux stock sera écoulé - El nuevo código será suministrado sólo cuando se agoten las existencias del antiguo - O novo código irá ser fornecido apenas quando o antigo esgotar stock

ACTIVE SAFETY



OSAS



USAS



OPAS



SKUDO

* $F_{1i} =$ Isothermal end force at 100% Cu p. 16 ** $F_{1p} =$ Polytropic end force at 100% Cu

Force color code	P		F ₀ Initial force ± 5% at +20°C +68°F	
	bar	psi	daN	lb
OR	10	145	5	11
PR	20	290	10	22
GR	60	870	30	67
BU	100	1450	50	112
RD	140	2030	70	157
YW	180	2610	90	202
BK	10-180	145-2610	5-90	11-202

Pressione da specificare in fase d'ordine.
Pressure to be specified when ordering.
Druck bei Bestellung anzugeben.
Pression à préciser lors de la commande.
La presión se debe especificar al realizar el pedido.
Pressão a ser especificada no pedido.

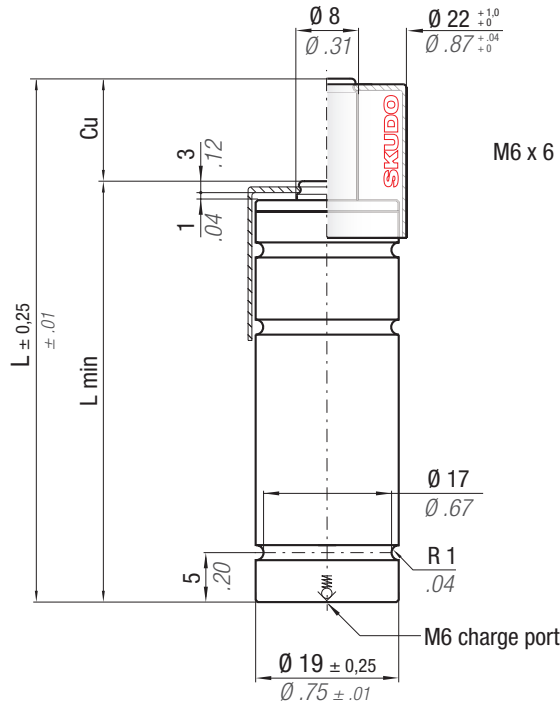

N ₂		0 - 80 °C 32 - 176 °F	ΔP ± 0,33 %/°C	P max 180 bar 2610 psi	P min 10 bar 145 psi	S 0,50 cm ² 0,078 in ²	SPM ~ 100 - 150 (at 20°C)	Max Speed 1,8 m/s 70,8 in/s	Maintenance kit Disposable
CODE	NEW	Cu	L	L min	F _{1i} *	F _{1p} **	V ₀		PED 2014/68/EU
PHASING OUT from 05/2019		mm inch	mm inch	mm inch	daN lb	daN lb	cm ³ in ³	~Kg ~lb	
MS90-007-A-...	MS90-007-B-...	7 0.28	62 2.44	55 2.17	1.19 x F ₀	1.35 x F ₀	2,6 0.16	0,07 0.15	✓
MS90-010-A-...	MS90-010-B-...	9,7 0.38	67,4 2.65	57,7 2.27	1.22 x F ₀	1.40 x F ₀	3,1 0.19	0,08 0.18	✓
MS90-012-A-...	MS90-012-B-...	12 0.47	72 2.83	60 2.36	1.24 x F ₀	1.44 x F ₀	3,5 0.21	0,08 0.18	✓
MS90-022-A-...	MS90-022-B-...	22 0.87	92 3.62	70 2.76	1.30 x F ₀	1.52 x F ₀	5,5 0.34	0,09 0.20	✓
MS90-035-A-...	MS90-035-B-...	35,1 1.38	118,2 4.65	83,1 3.27	1.33 x F ₀	1.57 x F ₀	8,1 0.49	0,11 0.24	✓
MS90-047-A-...	MS90-047-B-...	47 1.85	142 5.59	95 3.74	1.34 x F ₀	1.60 x F ₀	10,4 0.63	0,12 0.26	✓
MS90-060-A-...	MS90-060-B-...	60,5 2.38	172 6.77	111,5 4.39	1.35 x F ₀	1.61 x F ₀	13,4 0.82	0,14 0.31	✓
MS90-077-A-...	MS90-077-B-...	77 3.03	205 8.07	128 5.04	1.36 x F ₀	1.62 x F ₀	16,6 1.01	0,15 0.33	✓
MS90-097-A-...	MS90-097-B-...	97 3.82	245 9.65	148 5.83	1.37 x F ₀	1.64 x F ₀	20,6 1.26	0,17 0.37	✓
MS90-122-A-...	MS90-122-B-...	122 4.80	295 11.61	173 6.81	1.37 x F ₀	1.65 x F ₀	25,5 1.56	0,20 0.44	✓

**WARNING
REMOVE SKUDO**

Upside down mounting

Drop-in

FC 19 B
FCC 19 A

Bottom mount

NOT FOR

HOW TO ORDER

p. 53

INSTALLATION GUIDELINE

p. 205

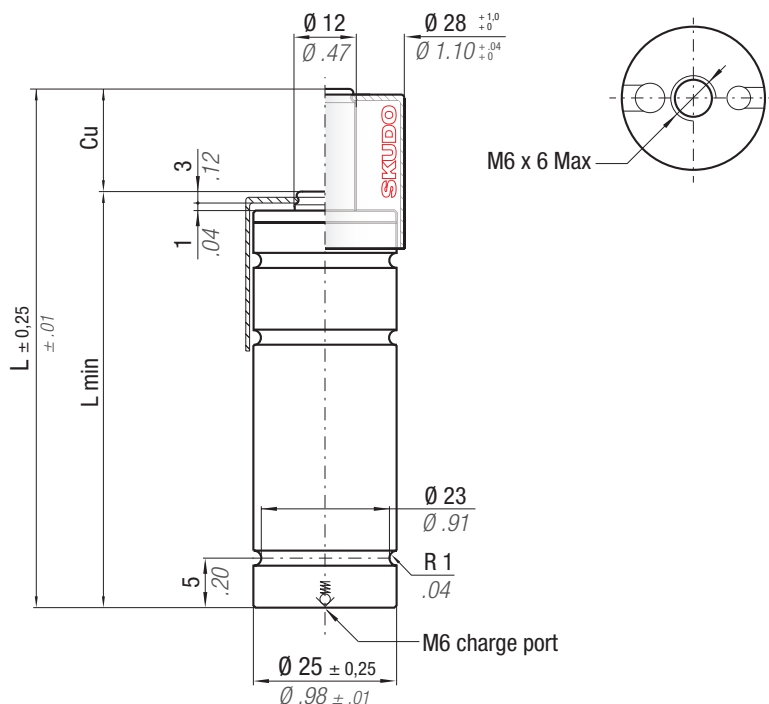

Il nuovo codice sarà fornito solo ad esaurimento del vecchio - The new code will be supplied only when the old will be out of stock - Der neue Kode wird nur angegeben, wenn der alte nicht mehr lieferbar ist - Le nouveau code sera fourni uniquement lorsque le vieux stock sera écoulé - El nuevo código será suministrado sólo cuando se agoten las existencias del antiguo - O novo código irá ser fornecido apenas quando o antigo esgotar stock

* F_{1i} = Isothermal end force at 100% Cu p. 16 ** F_{1p} = Polyphotic end force at 100% Cu

Force color code	P		Fo Initial force ± 5% at +20°C +68°F	
	bar	psi	daN	lb
OR	15	218	17	38
PR	25	363	28	63
GR	45	653	50	112
BU	90	1305	100	225
RD	135	1958	150	337
YW	180	2610	200	450
BK	10-180	145-2610	11-200	25-450

Pressione da specificare in fase d'ordine.
Pressure to be specified when ordering.
Druck bei Bestellung anzugeben.
Pression à préciser lors de la commande.
La presión se debe especificar al realizar el pedido.
Pressão a ser especificada no pedido.

ACTIVE SAFETY



OSAS



USAS



OPAS



SKUDO

MS

N ₂		0 - 80 °C 32 - 176 °F	ΔP ± 0,33 %/°C	P max 180 bar 2610 psi	P min 10 bar 145 psi	S 1,13 cm ² 0.175 in ²	SPM ~ 50 - 80 (at 20°C)	Max Speed 1,8 m/s 70.8 in/s	Maintenance kit Disposable
CODE	NEW	Cu	L	L min	F_{1i} *	F_{1p} **	V ₀	PED 2014/68/EU	
MS200 - 007 - A - ...	MS200 - 007 - B - ...	7 0.28	62 2.44	55 2.17	1.25 x F ₀	1.43 x F ₀	4,6 0.28	0,13 0.29	✓
MS200 - 010 - A - ...	MS200 - 010 - B - ...	9,7 0.38	67,4 2.65	57,7 2.27	1.30 x F ₀	1.50 x F ₀	5,6 0.34	0,13 0.29	✓
MS200 - 012 - A - ...	MS200 - 012 - B - ...	12 0.47	72 2.83	60 2.36	1.32 x F ₀	1.54 x F ₀	6,5 0.40	0,14 0.31	✓
MS200 - 022 - A - ...	MS200 - 022 - B - ...	22 0.87	92 3.62	70 2.76	1.39 x F ₀	1.65 x F ₀	10,2 0.62	0,16 0.35	✓
MS200 - 035 - A - ...	MS200 - 035 - B - ...	35,1 1.38	118,2 4.65	83,1 3.27	1.43 x F ₀	1.72 x F ₀	15,1 0.92	0,19 0.42	✓
MS200 - 047 - A - ...	MS200 - 047 - B - ...	47 1.85	142 5.59	95 3.74	1.45 x F ₀	1.75 x F ₀	19,6 1.20	0,20 0.44	✓
MS200 - 060 - A - ...	MS200 - 060 - B - ...	60,5 2.38	172 6.77	111,5 4.39	1.46 x F ₀	1.78 x F ₀	24,7 1.51	0,23 0.51	✓
MS200 - 077 - A - ...	MS200 - 077 - B - ...	77 3.03	205 8.07	128 5.04	1.47 x F ₀	1.80 x F ₀	30,8 1.88	0,26 0.57	✓
MS200 - 097 - A - ...	MS200 - 097 - B - ...	97 3.82	245 9.65	148 5.83	1.48 x F ₀	1.81 x F ₀	38,3 2.34	0,30 0.66	✓
MS200 - 122 - A - ...	MS200 - 122 - B - ...	122 4.80	295 11.61	173 6.81	1.49 x F ₀	1.82 x F ₀	47,7 2.91	0,34 0.75	✓

WARNING REMOVE SKUDO

Upside down mounting

Drop-In
 FC 25 B
FCC 25 A
 Bottom mount

HOW TO ORDER p. 53

INSTALLATION GUIDELINE p. 205

ISO	VDI	BMW	FCA
Ford	Mazda	MB	Nissan
PSA	Renault	VW	

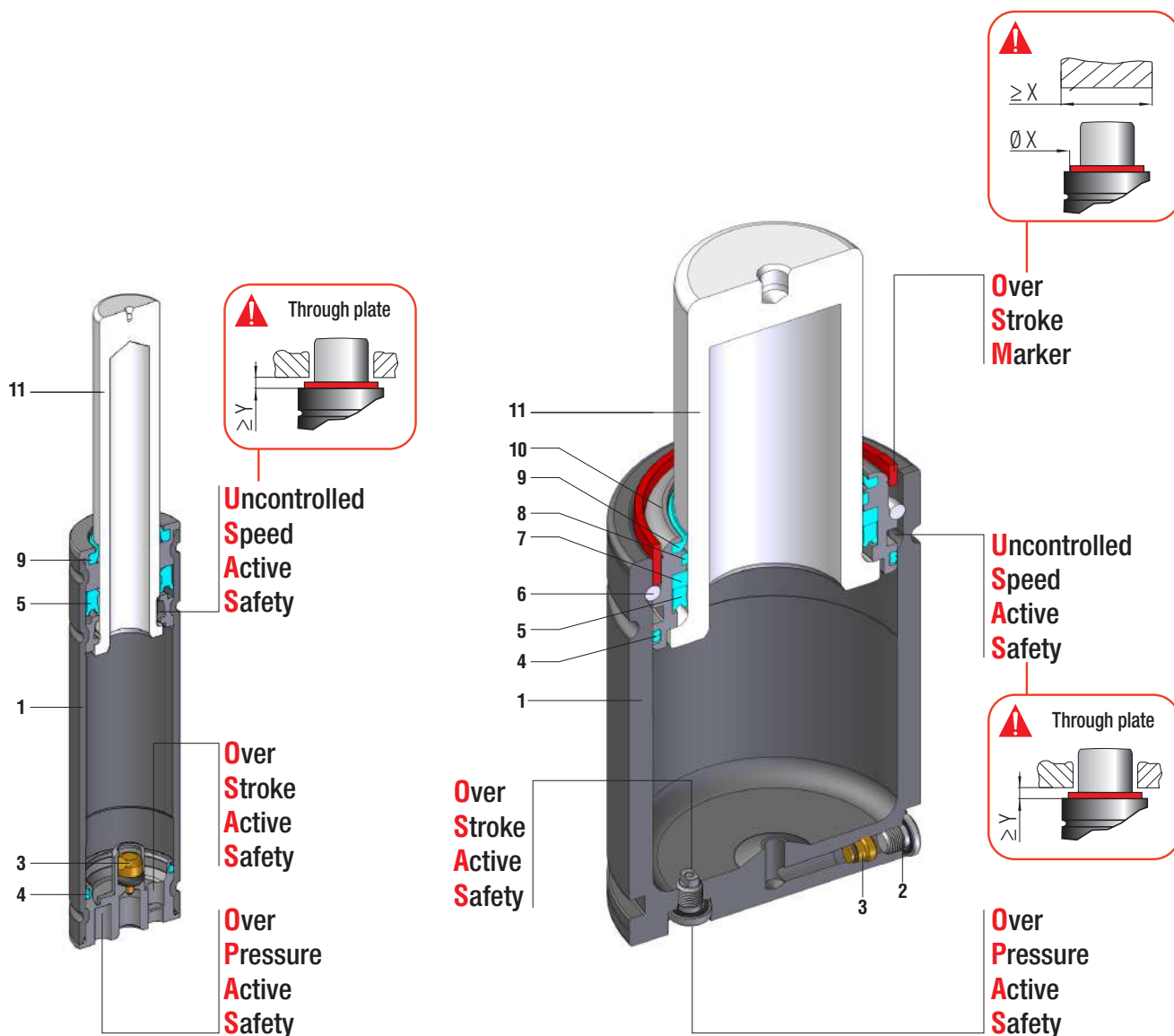

RV 170 - RV 320

RV 350 ÷ RV 20000

Minima altezza, massima forza - Minimum height, maximum force - Minimale Höhe, maximale Kraft
 Hauteur minimale, force maximale - Mínima altura, máxima fuerza - Altura mínima, força máxima

SEALING	ROD SEAL
DESIGN	BUSH - BODY DESIGN

1	Body	5	Rod seal	9	Rod wiper
2	Plug	6	Retaining ring	10	Bush
3	Valve	7	Back-up ring	11	Rod (nitrited superfinished)
4	Dual ring seal	8	Guide ring		

RANGE CHART

Model	Body Ø		Stroke Cu		Initial force F0						
	mm	inch	mm	inch	daN	lb	OSAS	USAS	OPAS	SKUDO	SW
RV 170	19	0.75	7 - 125	0.28 - 4.92	170	382	✓	✓	✓	-	✓
RV 320	25	0.98	7 - 125	0.28 - 4.92	320	719	✓	✓	✓	-	✓
RV 350	32	1.26	10 - 125	0.39 - 4.92	360	809	✓	✓	✓	-	✓
RV 500	38	1.50	10 - 125	0.39 - 4.92	470	1057	✓	✓	✓	-	✓
RV 750	45	1.77	10 - 125	0.39 - 4.92	740	1664	✓	✓	✓	-	✓
RV 1000	50	1.97	10 - 125	0.39 - 4.92	920	2068	✓	✓	✓	-	✓
RV 1200	50	1.97	10 - 125	0.39 - 4.92	1047	2354	✓	✓	✓	-	✓
RV 1500	63	2.48	10 - 125	0.39 - 4.92	1530	3440	✓	✓	✓	-	✓
RV 2400	75	2.95	10 - 125	0.39 - 4.92	2385	5362	✓	✓	✓	-	✓
RV 4200	95	3.74	16 - 125	0.63 - 4.92	4240	9532	✓	✓	✓	-	✓
RV 6600	120	4.72	16 - 125	0.63 - 4.92	6630	14905	✓	✓	✓	-	✓
RV 9500	150	5.91	19 - 125	0.75 - 4.92	9540	21447	✓	✓	✓	-	✓
RV 12000	150	5.91	19 - 125	0.75 - 4.92	11780	26470	✓	✓	✓	-	✓
RV 20000	195	7.68	19 - 125	0.75 - 4.92	19910	44738	✓	✓	✓	-	✓

✓ Built-in as standard

✓ Optional upon request

HOW TO ORDER

Series _____ Revision code _____

Model **RV 1000-063-B-E-W**

Stroke _____ Version _____

Available versions

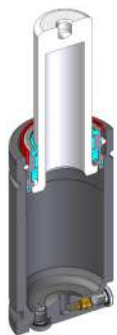

RV 1000-063-B
Standard code



Self contained

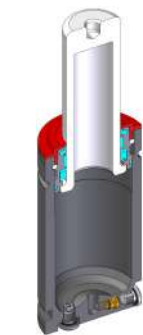

RV 1000-063-B-W
Add "-W" to standard code



Self contained



+ Secondary wiper

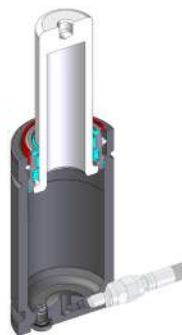

RV 1000-063-B-N
Add "-N" to standard code



Linkable

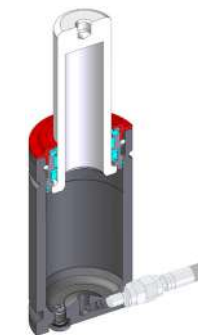

RV 1000-063-B-N-W
Add "-N-W" to standard code



Linkable



+ Secondary wiper

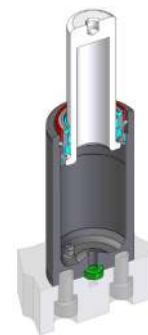

RV 1000-063-B-E
Add "-E" to standard code



Easy Manifold

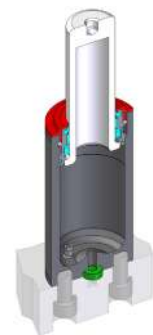

RV 1000-063-B-E-W
Add "-E-W" to standard code



Easy Manifold



+ Secondary wiper

RV 170

ISO 11901 - 3 B8 3180 220 000 004(MB)	VDI 3003 - Blatt 3 39D 997 (VW)	B2 4005 (BMW)	075.90.60 (FCA)
------------------------------------------	------------------------------------	---------------	-----------------



Il nuovo codice sarà fornito solo ad esaurimento del vecchio - The new code will be supplied only when the old will be out of stock - Der neue Kode wird nur angegeben, wenn der alte nicht mehr lieferbar ist - Le nouveau code sera fourni uniquement lorsque le vieux stock sera écoulé - El nuevo código será suministrado sólo cuando se agoten las existencias del antiguo - O novo código irá ser fornecido apenas quando o antigo esgotar stock

ACTIVE SAFETY



OSAS



USAS



OPAS

easu MANIFOLD p. 247 p. 262

* $F_{1i} =$ Isothermal end force at 100% Cu p. 16 ** $F_{1p} =$ Polytrophic end force at 100% Cu

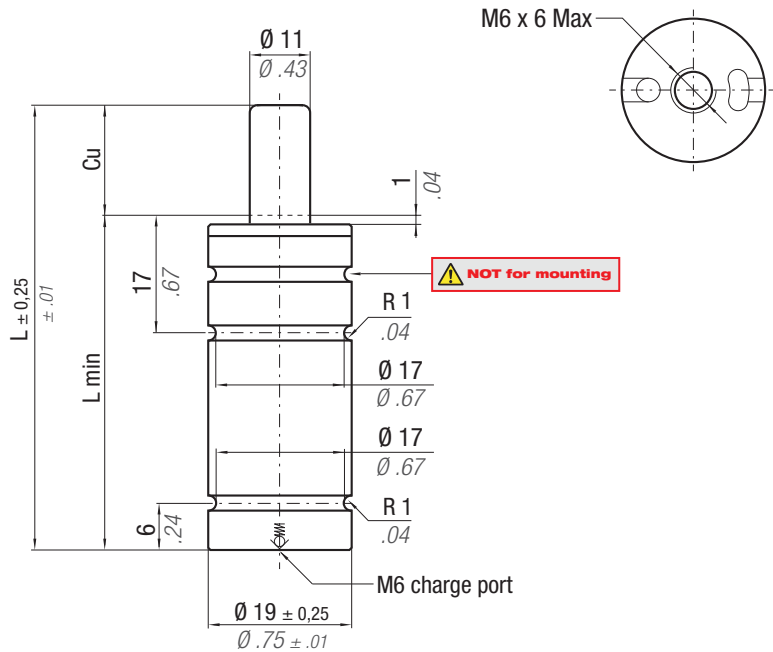

N ₂	0 - 80 °C 32 - 176 °F	ΔP ± 0,33 %/°C	P max 180 bar 2610 psi	P min 20 bar 290 psi	S 0,95 cm ² 0,147 in ²	SPM ~ 40 - 100 (at 20°C)	Max Speed 1,8 m/s 70.8 in/s	Maintenance kit Disposable
----------------	--------------------------	---------------------------	------------------------------	----------------------------	----------------------------------------------------	--------------------------------	-----------------------------------	-------------------------------

CODE PHASING OUT from 05/2019	NEW	Cu		L		L min		F ₀		F _{1i} *		F _{1p} **		V ₀		PED 2014/68/EU		
		mm	inch	mm	inch	mm	inch	daN	lb	daN	lb	daN	lb	cm ³	in ³		~Kg	~lb
RV 170 - 007 - B	RV 170 - 007 - C	7	0.28	44	1.73	37	1.46	170 ± 5% 180 bar 2610psi + 20 °C +68 °F	382	274	616	320	719	2,1	0.13	0,06	0.13	✓
RV 170 - 010 - B	RV 170 - 010 - C	10	0.39	50	1.97	40	1.57			285	641	337	758	2,9	0.18	0,06	0.13	✓
RV 170 - 013 - B	RV 170 - 013 - C	13	0.51	56	2.20	43	1.69			292	656	348	782	3,6	0.22	0,07	0.15	✓
RV 170 - 015 - B	RV 170 - 015 - C	15	0.59	60	2.36	45	1.77			296	665	353	794	4,1	0.25	0,07	0.15	✓
RV 170 - 019 - B	RV 170 - 019 - C	19	0.75	68	2.68	49	1.93			301	677	361	812	5,0	0.31	0,07	0.16	✓
RV 170 - 025 - B	RV 170 - 025 - C	25	0.98	80	3.15	55	2.17			306	688	369	830	6,4	0.39	0,08	0.17	✓
RV 170 - 032 - B	RV 170 - 032 - C	32	1.26	94	3.7	62	2.44			310	697	374	841	8,1	0.49	0,09	0.19	✓
RV 170 - 038 - B	RV 170 - 038 - C	38	1.5	106	4.17	68	2.68			312	701	378	850	9,5	0.58	0,09	0.20	✓
RV 170 - 050 - B	RV 170 - 050 - C	50	1.97	130	5.12	80	3.15			315	708	382	859	12,4	0.76	0,11	0.23	✓
RV 170 - 063 - B	RV 170 - 063 - C	63	2.48	156	6.14	93	3.66			317	713	385	866	15,5	0.95	0,12	0.26	✓
RV 170 - 075 - B	RV 170 - 075 - C	75	2.95	185	7.28	110	4.33			318	715	387	870	18,3	1.12	0,14	0.30	✓
RV 170 - 080 - B	RV 170 - 080 - C	80	3.15	195	7.68	115	4.53			319	717	388	872	19,5	1.19	0,14	0.31	✓
RV 170 - 100 - B	RV 170 - 100 - C	100	3.94	235	9.25	135	5.31			320	719	390	877	24,3	1.48	0,16	0.36	✓
RV 170 - 125 - B	RV 170 - 125 - C	125	4.92	285	11.22	160	6.3			321	722	391	879	30,2	1.84	0,19	0.42	✓

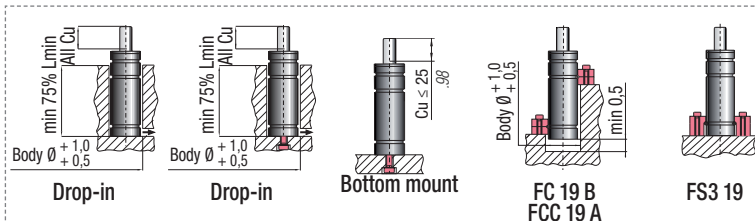

HOW TO ORDER p. 57

INSTALLATION GUIDELINE p. 205



SW

ACTIVE SAFETY



OSAS



USAS

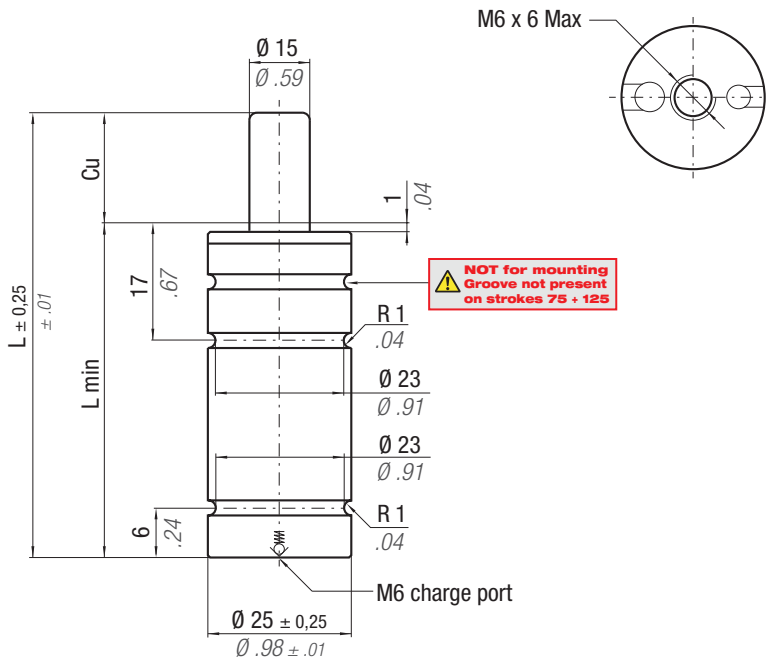

OPAS

RV

Il nuovo codice sarà fornito solo ad esaurimento del vecchio

The new code will be supplied only when the old will be out of stock

Der neue Kode wird nur angegeben, wenn der alte nicht mehr lieferbar ist

Le nouveau code sera fourni uniquement lorsque le vieux stock sera écoulé

El nuevo código será suministrado sólo cuando se agoten las existencias del antiguo

O novo código irá ser fornecido apenas quando o antigo esgotar stock



* $F_{1i} =$

Isothermal end force at 100% Cu

p. 16

** $F_{1p} =$

Polytropic end force at 100% Cu

N ₂		0 - 80 °C 32 - 176 °F	ΔP ± 0,33 %/°C	P max 180 bar 2610 psi	P min 20 bar 290 psi	S 1,77 cm ² 0.27 in ²	SPM ~ 40 - 100 (at 20°C)	Max Speed 1,8 m/s 70.8 in/s	Maintenance kit Disposable	
CODE	NEW	Cu	L	L min	F ₀	F _{1i} *	F _{1p} **	V ₀	PED	
PHASING OUT from 01/2020		mm inch	mm inch	mm inch	Initial force daN lb	End force * daN lb	End force ** daN lb	cm ³ in ³	~Kg ~lb	2014/68/EU
RV 320 - 007 - B	RV 320 - 007 - C	7 0.28	44 1.73	37 1.46	320 719 ± 5% 180 bar 2610psi + 20 °C +68 °F	471 1059	540 1214	4,6 0.28	0,10 0.22	✓
RV 320 - 010 - B	RV 320 - 010 - C	10 0.39	50 1.97	40 1.57		495 1112	574 1291	6,0 0.37	0,10 0.23	✓
RV 320 - 013 - B	RV 320 - 013 - C	13 0.51	56 2.20	43 1.69		511 1148	598 1344	7,3 0.45	0,11 0.24	✓
RV 320 - 015 - B	RV 320 - 015 - C	15 0.59	60 2.36	45 1.77		519 1167	610 1371	8,2 0.50	0,11 0.24	✓
RV 320 - 019 - B	RV 320 - 019 - C	19 0.75	68 2.68	49 1.93		531 1195	628 1412	10,1 0.62	0,12 0.26	✓
RV 320 - 025 - B	RV 320 - 025 - C	25 0.98	80 3.15	55 2.17		544 1223	647 1454	12,8 0.78	0,13 0.28	✓
RV 320 - 032 - B	RV 320 - 032 - C	32 1.26	94 3.70	62 2.44		553 1244	661 1486	15,9 0.97	0,14 0.31	✓
RV 320 - 038 - B	RV 320 - 038 - C	38 1.50	106 4.17	68 2.68		559 1257	669 1505	18,6 1.14	0,15 0.33	✓
RV 320 - 050 - B	RV 320 - 050 - C	50 1.97	130 5.12	80 3.15		567 1274	681 1531	24,1 1.47	0,17 0.37	✓
RV 320 - 063 - B	RV 320 - 063 - C	63 2.48	156 6.14	93 3.66		572 1286	689 1549	29,9 1.82	0,19 0.42	✓
RV 320 - 075 - B	RV 320 - 075 - C	75 2.95	185 7.28	110 4.33		570 1282	686 1543	35,8 2.18	0,22 0.48	✓
RV 320 - 080 - B	RV 320 - 080 - C	80 3.15	195 7.68	115 4.53		572 1285	688 1548	38,1 2.33	0,23 0.50	✓
RV 320 - 100 - B	RV 320 - 100 - C	100 3.94	235 9.25	135 5.31		576 1295	695 1562	47,1 2.87	0,26 0.57	✓
RV 320 - 125 - B	RV 320 - 125 - C	125 4.92	285 11.22	160 6.30		580 1303	700 1574	58,4 3.56	0,30 0.66	✓

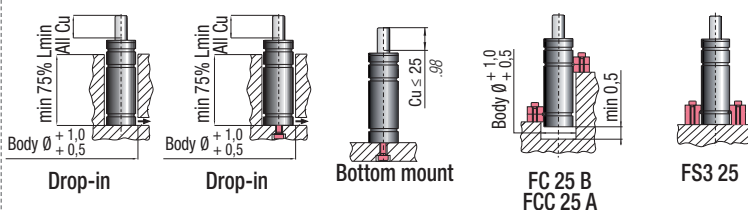
HOW TO ORDER

p. 57

INSTALLATION GUIDELINE

p. 205

RV 350

ISO 11901 - 3	VDI 3003 - Blatt 3	B2 4005 (BMW)	075.90.60 (FCA)
W-DX35-6204 (Ford)	B8 3180 220 000 004(MB)	39D 997 (VW)	



OSAS + OSM = OVER STROKE ACTIVE SAFETY + OVER STROKE MARKER

ACTIVE SAFETY



OSAS



USAS



OPAS

Il nuovo codice sarà fornito solo ad esaurimento del vecchio
 The new code will be supplied only when the old will be out of stock
 Der neue Kode wird nur angegeben, wenn der alte nicht mehr lieferbar ist
 Le nouveau code sera fourni uniquement lorsque le vieux stock sera écoulé
 El nuevo código será suministrado sólo cuando se agoten las existencias del antiguo
 O novo código irá ser fornecido apenas quando o antigo esgotar stock

easU MANIFOLD p. 247

p. 262

* F_{1i} = Isothermal end force at 100% Cu



p. 16

** F_{1p} = Polyphobic end force at 100% Cu

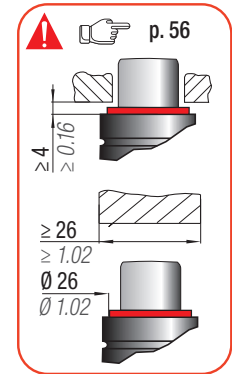
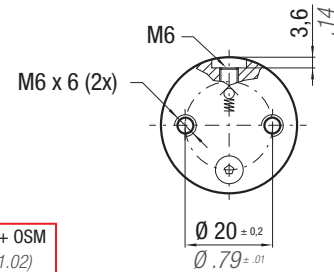
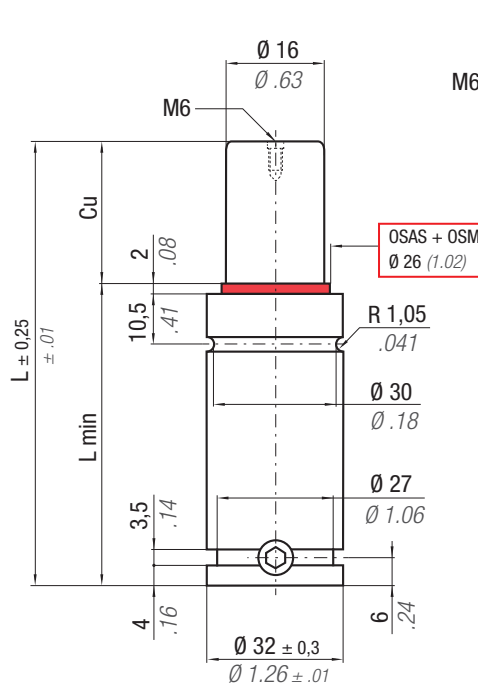

N ₂		0 - 80 °C 32 - 176 °F	ΔP ± 0,33 %/°C	P max 180 bar 2610 psi	P min 20 bar 290 psi	S 2,01 cm ² 0,312 in ²	SPM ~ 20 - 100 (at 20°C)	Max Speed 1,8 m/s 70,8 in/s	Maintenance kit 39BMRV00350C	
CODE PHASING OUT from 04/2021	NEW	Cu	L	L min	F ₀	F _{1i} *	F _{1p} **	V ₀	PED 2014/68/EU	
RV 350 - 010 - A	♦ RV 350 - 010 - B	10 0.39	50 1.97	40 1.57	360 809 ± 5% 180 bar 2610psi + 20 °C + 68 °F	531 1194	607 1366	7,7 0.47	0,17 0.36	✓
RV 350 - 013 - A	RV 350 - 013 - B	13 0.51	56 2.20	43 1.69		544 1224	627 1409	9,5 0.58	0,18 0.39	✓
RV 350 - 016 - A	RV 350 - 016 - B	16 0.63	62 2.44	46 1.81		554 1245	641 1440	11,2 0.68	0,19 0.41	✓
RV 350 - 019 - A	RV 350 - 019 - B	19 0.75	68 2.68	49 1.93		561 1261	651 1463	13,0 0.79	0,19 0.43	✓
RV 350 - 025 - A	RV 350 - 025 - B	25 0.98	80 3.15	55 2.17		571 1283	665 1496	16,6 1.01	0,21 0.47	✓
RV 350 - 032 - A	RV 350 - 032 - B	32 1.26	94 3.70	62 2.44		578 1300	676 1520	20,7 1.26	0,24 0.52	✓
RV 350 - 038 - A	RV 350 - 038 - B	38 1.50	106 4.17	68 2.68		583 1310	683 1535	24,3 1.48	0,26 0.56	✓
RV 350 - 050 - A	RV 350 - 050 - B	50 1.97	130 5.12	80 3.15		589 1323	691 1554	31,4 1.92	0,30 0.65	✓
RV 350 - 063 - A	RV 350 - 063 - B	63 2.48	156 6.14	93 3.66		593 1333	697 1568	39,1 2.39	0,34 0.74	✓
RV 350 - 075 - A	RV 350 - 075 - B	75 2.95	180 7.09	105 4.13		595 1338	701 1576	46,3 2.83	0,38 0.83	✓
RV 350 - 080 - A	RV 350 - 080 - B	80 3.15	190 7.48	110 4.33	596 1340	702 1579	49,2 3.00	0,39 0.86	✓	
RV 350 - 100 - A	RV 350 - 100 - B	100 3.94	230 9.06	130 5.12	599 1346	706 1588	61,1 3.73	0,46 1.01	✓	
RV 350 - 125 - A	RV 350 - 125 - B	125 4.92	280 11.02	155 6.10	606 1363	717 1613	74,9 4.57	0,54 1.18	✓	

♦ Disposable

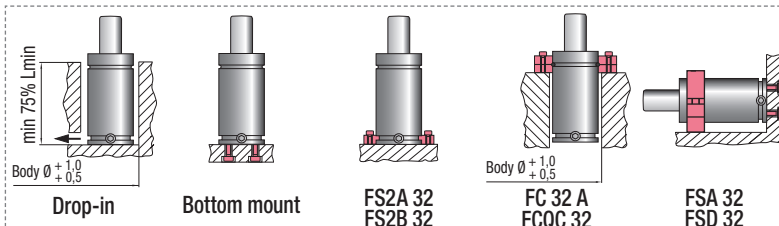

HOW TO ORDER
 p. 57

INSTALLATION GUIDELINE
 p. 205

ISO 11901 - 3	VDI 3003 - Blatt 3	B2 4005 (BMW)	075.90.60 (FCA)
W-DX35-6204 (Ford)	B8 3180 220 000 004(MB)	K 32 H (Nissan)	E24.54.815.G (PSA)
EM24.54.700 (Renault)	39D 997 (VW)		



ACTIVE SAFETY



OSAS



USAS



OPAS

RV

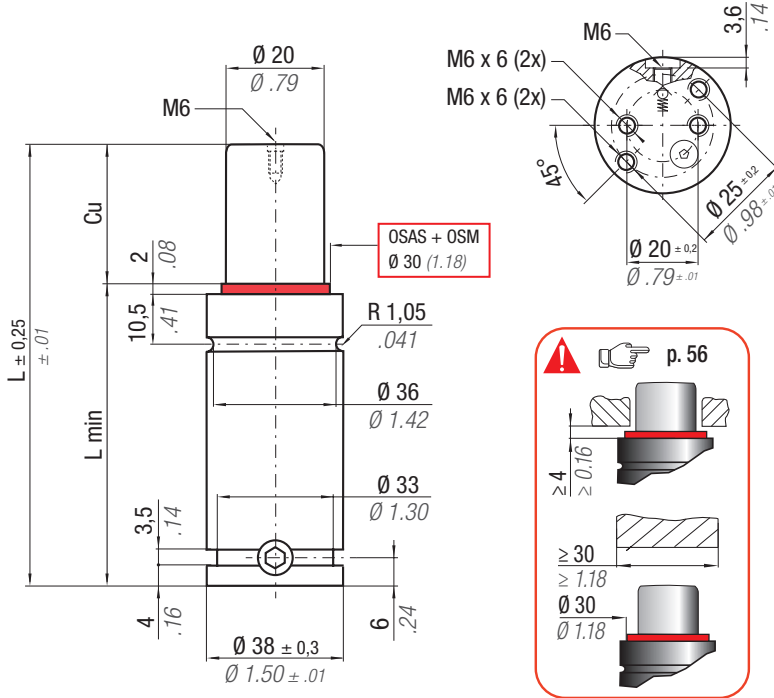

OSAS + OSM = OVER STROKE ACTIVE SAFETY + OVER STROKE MARKER

Il nuovo codice sarà fornito solo ad esaurimento del vecchio

The new code will be supplied only when the old will be out of stock

Der neue Kode wird nur angegeben, wenn der alte nicht mehr lieferbar ist

Le nouveau code sera fourni uniquement lorsque le vieux stock sera écoulé

El nuevo código será suministrado sólo cuando se agoten las existencias del antiguo stock

O novo código irá ser fornecido apenas quando o antigo esgotar stock

easU MANIFOLD p. 247

p. 262

* $F_{1i} =$

Isothermal end force at 100% Cu

p. 16

** $F_{1p} =$

Polytrophic end force at 100% Cu

		0 - 80 °C 32 - 176 °F	ΔP ± 0,33 %/°C	P max 150 bar 2175 psi	P min 20 bar 290 psi	S 3,14 cm ² 0.487 in ²	SPM ~ 20 - 100 (at 20°C)	Max Speed 1,8 m/s 70.8 in/s	Maintenance kit 39BMRV00500C	
CODE		Cu	L	L min	F0	F _{1i} *	F _{1p} **	V0		PED 2014/68/EU
PHASING OUT from 04/2021	NEW	mm inch	mm inch	mm inch	Initial force daN lb	End force * daN lb	End force ** daN lb	cm ³ in ³	~Kg ~lb	✓
RV 500 - 010 - A	◆ RV 500 - 010 - B	10 0.39	50 1.97	40 1.57	470 1057 ± 5% 150 bar 2175psi + 20 °C +68 °F	696 1565	828 1862	11,2 0.68	0,27 0.60	✓
RV 500 - 013 - A	RV 500 - 013 - B	13 0.51	56 2.20	43 1.69		716 1609	859 1931	13,8 0.84	0,25 0.55	✓
RV 500 - 016 - A	RV 500 - 016 - B	16 0.63	62 2.44	46 1.81		730 1641	882 1982	16,3 0.99	0,26 0.57	✓
RV 500 - 019 - A	RV 500 - 019 - B	19 0.75	68 2.68	49 1.93		740 1664	899 2020	18,9 1.15	0,28 0.62	✓
RV 500 - 025 - A	RV 500 - 025 - B	25 0.98	80 3.15	55 2.17		755 1698	922 2074	24,0 1.46	0,31 0.68	✓
RV 500 - 032 - A	RV 500 - 032 - B	32 1.26	94 3.70	62 2.44		766 1723	941 2115	30,0 1.83	0,34 0.75	✓
RV 500 - 038 - A	RV 500 - 038 - B	38 1.50	106 4.17	68 2.68		773 1738	952 2140	35,1 2.14	0,37 0.82	✓
RV 500 - 050 - A	RV 500 - 050 - B	50 1.97	130 5.12	80 3.15		782 1759	967 2173	45,3 2.76	0,43 0.95	✓
RV 500 - 063 - A	RV 500 - 063 - B	63 2.48	156 6.14	93 3.66		789 1773	977 2196	56,4 3.44	0,49 1.08	✓
RV 500 - 075 - A	RV 500 - 075 - B	75 2.95	180 7.09	105 4.13		792 1782	984 2211	66,6 4.06	0,54 1.19	✓
RV 500 - 080 - A	RV 500 - 080 - B	80 3.15	190 7.48	110 4.33		794 1785	986 2216	70,8 4.32	0,57 1.26	✓
RV 500 - 100 - A	RV 500 - 100 - B	100 3.94	230 9.06	130 5.12		798 1794	992 2231	87,9 5.36	0,66 1.46	✓
RV 500 - 125 - A	RV 500 - 125 - B	125 4.92	280 11.02	155 6.10		801 1801	998 2243	109,2 6.66	0,78 1.72	✓

◆ Disposable

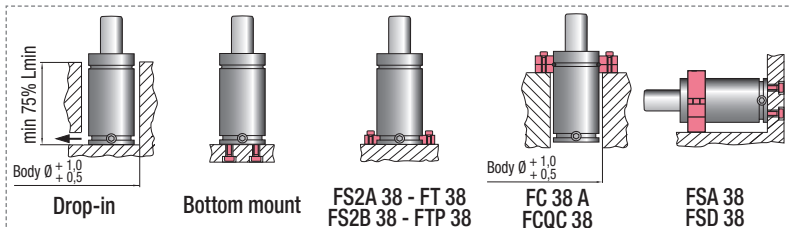

HOW TO ORDER

p. 57

INSTALLATION GUIDELINE

p. 205

RV 750

ISO 11901 - 3 B8 3180 220 000 004(MB)	VDI 3003 - Blatt 3 E24.54.815.G (PSA)	B2 4005 (BMW) 39D 997 (VW)	W-DX35-6204 (Ford)
------------------------------------------	------------------------------------------	-------------------------------	--------------------



OSAS + OSM = OVER STROKE ACTIVE SAFETY + OVER STROKE MARKER

ACTIVE SAFETY



OSAS



USAS



OPAS

Il nuovo codice sarà fornito solo ad esaurimento del vecchio

The new code will be supplied only when the old will be out of stock

Der neue Kode wird nur angegeben, wenn der alte nicht mehr lieferbar ist

Le nouveau code sera fourni uniquement lorsque le vieux stock sera écoulé

El nuevo código será suministrado sólo cuando se agoten las existencias del antiguo

O novo código irá ser fornecido apenas quando o antigo esgotar stock

easU MANIFOLD p. 247

p. 262

* F_{1i} = Isothermal end force at 100% Cu p. 16

** F_{1p} = Polytrophic end force at 100% Cu

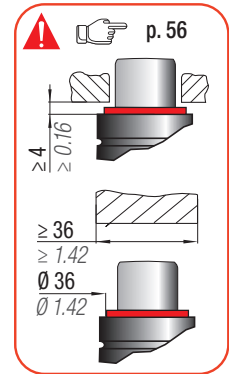
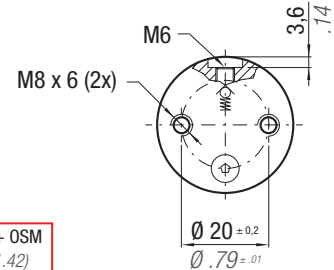
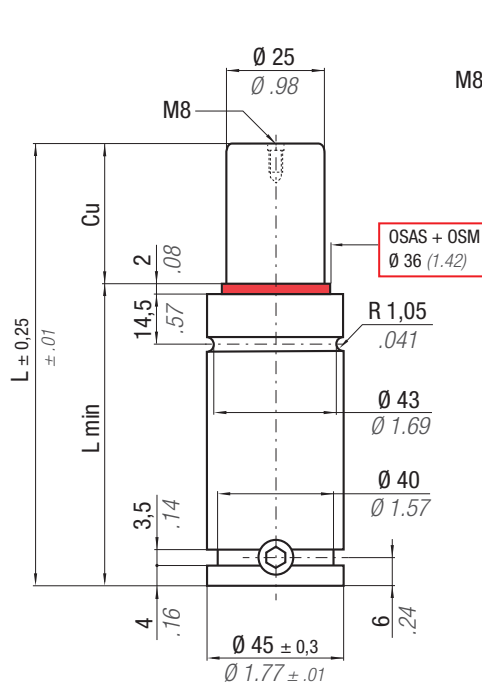

N₂	0 - 80 °C 32 - 176 °F	ΔP ± 0,33 %/°C	P max 150 bar 2175 psi	P min 20 bar 290 psi	S 4,91 cm ² 0,761 in ²	SPM ~ 20 - 100 (at 20°C)	Max Speed 1,8 m/s 70,8 in/s	Maintenance kit 39BMRV00750C
----------------------	--------------------------	--------------------------	-------------------------------------	-----------------------------------	-----------------------------------------------------------	---------------------------------------	------------------------------------------	----------------------------------------

CODE PHASING OUT from 04/2021	NEW	Cu		L		L min		F ₀		F _{1i} *		F _{1p} **		V ₀		PED 2014/68/EU			
		mm	inch	mm	inch	mm	inch	daN	lb	daN	lb	daN	lb	cm ³	in ³		~Kg	~lb	
RV 750 - 010 - A	♦ RV 750 - 010 - B	10	0.39	52	2.05	42	1.65	740 ± 5%	1664	1118	2514	1343	3018	16,6	1.01	0,36	0,79	✓	
RV 750 - 013 - A	RV 750 - 013 - B	13	0.51	58	2.28	45	1.77			1152	2590	1396	3139	20,4	1.24	0,38	0,84	✓	
RV 750 - 016 - A	RV 750 - 016 - B	16	0.63	64	2.52	48	1.89			1176	2644	1435	3227	24,1	1.47	0,40	0,88	✓	
RV 750 - 019 - A	RV 750 - 019 - B	19	0.75	70	2.76	51	2.01			1194	2685	1465	3293	27,9	1.70	0,42	0,93	✓	
RV 750 - 025 - A	RV 750 - 025 - B	25	0.98	82	3.23	57	2.24			1220	2743	1507	3388	35,5	2.17	0,45	0,99	✓	
RV 750 - 032 - A	RV 750 - 032 - B	32	1.26	96	3.78	64	2.52			1240	2787	1539	3460	44,3	2.70	0,50	1.10	✓	
RV 750 - 038 - A	RV 750 - 038 - B	38	1.50	108	4.25	70	2.76			150 bar	1251	2813	1558	3503	51,9	3.17	0,54	1.19	✓
RV 750 - 050 - A	RV 750 - 050 - B	50	1.97	132	5.20	82	3.23			2175psi	1267	2848	1584	3562	67,0	4.09	0,61	1.34	✓
RV 750 - 063 - A	RV 750 - 063 - B	63	2.48	158	6.22	95	3.74			+ 20 °C + 68 °F	1278	2873	1602	3602	83,4	5.09	0,70	1.54	✓
RV 750 - 075 - A	RV 750 - 075 - B	75	2.95	182	7.17	107	4.21			1285	2888	1614	3628	98,5	6.01	0,78	1.72	✓	
RV 750 - 080 - A	RV 750 - 080 - B	80	3.15	192	7.56	112	4.41	1287	2893	1618	3637	104,8	6.40	0,81	1.79	✓			
RV 750 - 100 - A	RV 750 - 100 - B	100	3.94	232	9.13	132	5.20	1294	2909	1629	3663	130,1	7.94	0,94	2.07	✓			
RV 750 - 125 - A	RV 750 - 125 - B	125	4.92	282	11.10	157	6.18	1300	2922	1639	3685	161,6	9.86	1,10	2.43	✓			

♦ Disposable

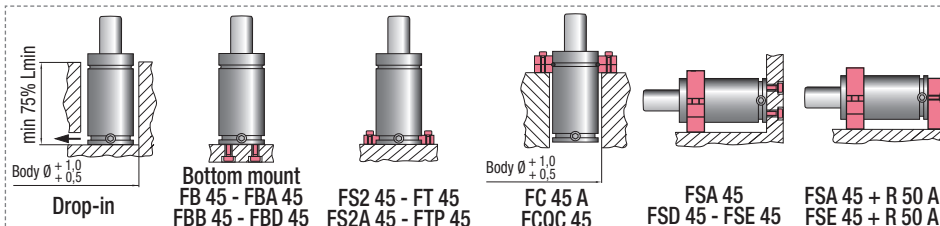

HOW TO ORDER p. 57

INSTALLATION GUIDELINE p. 205



ACTIVE SAFETY



OSAS



USAS



OPAS

RV

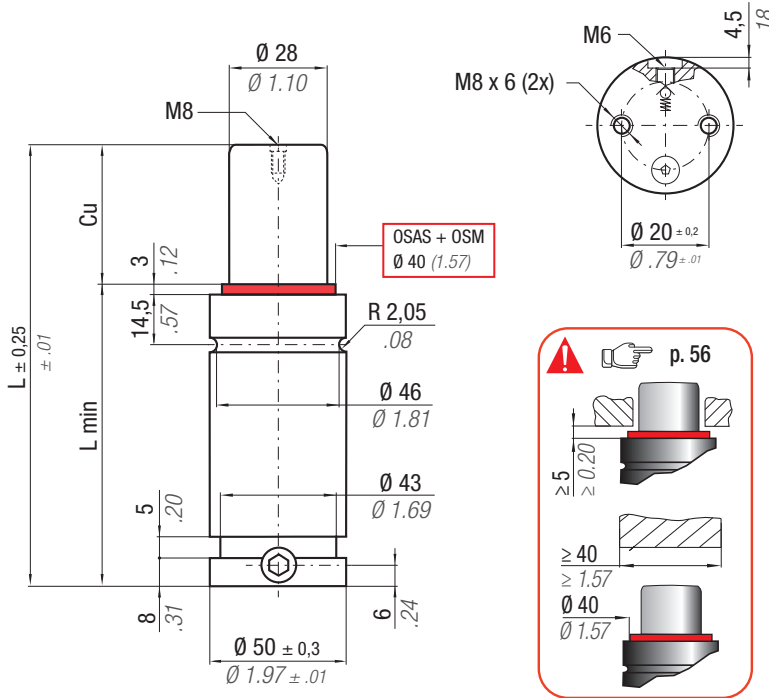

OSAS + OSM = OVER STROKE ACTIVE SAFETY + OVER STROKE MARKER

Il nuovo codice sarà fornito solo ad esaurimento del vecchio

The new code will be supplied only when the old will be out of stock

Der neue Kode wird nur angegeben, wenn der alte nicht mehr lieferbar ist

Le nouveau code sera fourni uniquement lorsque le vieux stock sera écoulé

El nuevo código será suministrado sólo cuando se agoten las existencias del antiguo

O novo código irá ser fornecido apenas quando o antigo esgotar stock

easU MANIFOLD p. 247

p. 262

* $F_{1i} =$

Isothermal end force at 100% Cu

p. 16

** $F_{1p} =$

Polytrophic end force at 100% Cu

p. 16

N ₂	0 - 80 °C 32 - 176 °F	ΔP ± 0,33 %/°C	P max 150 bar 2175 psi	P min 20 bar 290 psi	S 6,15 cm ² 0.953 in ²	SPM ~ 20 - 100 (at 20°C)	Max Speed 1,8 m/s 70.8 in/s	Maintenance kit 39BMRV01000C		
CODE PHASING OUT from 04/2021	NEW	Cu	L	L min	F ₀ Initial force	F _{1i} * End force *	F _{1p} ** End force **	V ₀	PED 2014/68/EU	
RV 1000 - 010 - A	◆ RV 1000 - 010 - B	10 0.39	58 2.28	48 1.89	920 2068 ± 5%	1321 2969	1554 3494	23,7 1.45	0,49 1.08	✓
RV 1000 - 013 - A	◆ RV 1000 - 013 - B	13 0.51	64 2.52	51 2.01		1370 3079	1631 3667	28,4 1.73	0,51 1.12	✓
RV 1000 - 016 - A	RV 1000 - 016 - B	16 0.63	70 2.76	54 2.13		1407 3163	1690 3800	33,1 2.02	0,54 1.19	✓
RV 1000 - 019 - A	RV 1000 - 019 - B	19 0.75	76 2.99	57 2.24		1436 3229	1737 3906	37,7 2.30	0,56 1.23	✓
RV 1000 - 025 - A	RV 1000 - 025 - B	25 0.98	88 3.46	63 2.48		1479 3326	1807 4062	47,1 2.87	0,61 1.34	✓
RV 1000 - 032 - A	RV 1000 - 032 - B	32 1.26	102 4.02	70 2.76		1514 3403	1863 4187	58,0 3.54	0,67 1.48	✓
RV 1000 - 038 - A	RV 1000 - 038 - B	38 1.50	114 4.49	76 2.99		1535 3451	1897 4266	67,4 4.11	0,72 1.59	✓
RV 1000 - 050 - A	RV 1000 - 050 - B	50 1.97	138 5.43	88 3.46		1564 3517	1946 4375	86,1 5.25	0,81 1.79	✓
RV 1000 - 063 - A	RV 1000 - 063 - B	63 2.48	164 6.46	101 3.98		1585 3564	1981 4453	106,3 6.49	0,92 2.03	✓
RV 1000 - 075 - A	RV 1000 - 075 - B	75 2.95	188 7.40	113 4.45		1599 3594	2003 4503	125,0 7.63	1,01 2.23	✓
RV 1000 - 080 - A	RV 1000 - 080 - B	80 3.15	198 7.80	118 4.65	1603 3605	2011 4520	132,8 8.10	1,05 2.31	✓	
RV 1000 - 100 - A	RV 1000 - 100 - B	100 3.94	238 9.37	138 5.43	1618 3636	2034 4573	164,0 10.01	1,21 2.67	✓	
RV 1000 - 125 - A	RV 1000 - 125 - B	125 4.92	288 11.34	163 6.42	1629 3663	2054 4617	202,9 12.38	1,41 3.11	✓	

◆ Disposable

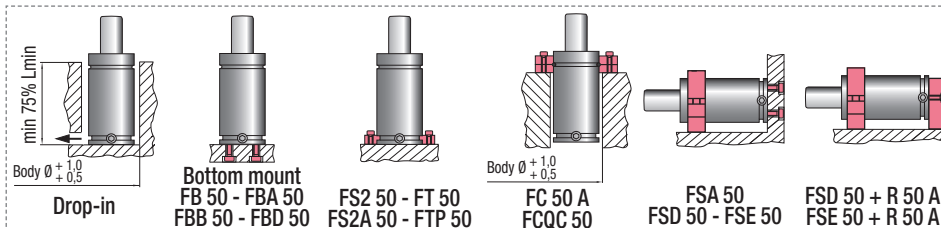

HOW TO ORDER

p. 57

INSTALLATION GUIDELINE

p. 205



OSAS + OSM = OVER STROKE ACTIVE SAFETY + OVER STROKE MARKER

ACTIVE SAFETY



OSAS



USAS



OPAS

Il nuovo codice sarà fornito solo ad esaurimento del vecchio

The new code will be supplied only when the old will be out of stock

Der neue Kode wird nur angegeben, wenn der alte nicht mehr lieferbar ist

Le nouveau code sera fourni uniquement lorsque le vieux stock sera épuisé

El nuevo código será suministrado sólo cuando se agoten las existencias del antiguo

O novo código irá ser fornecido apenas quando o antigo esgotar stock

easU MANIFOLD p. 247

p. 262

* F_{1i} =

Isothermal end force at 100% Cu



p. 16

** F_{1p} =

Polytropic end force at 100% Cu

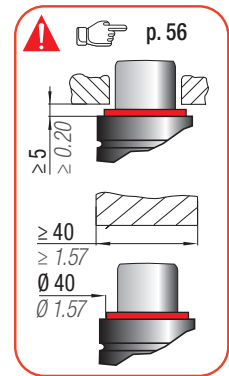
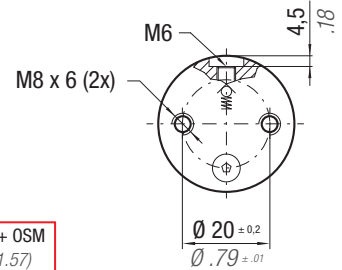
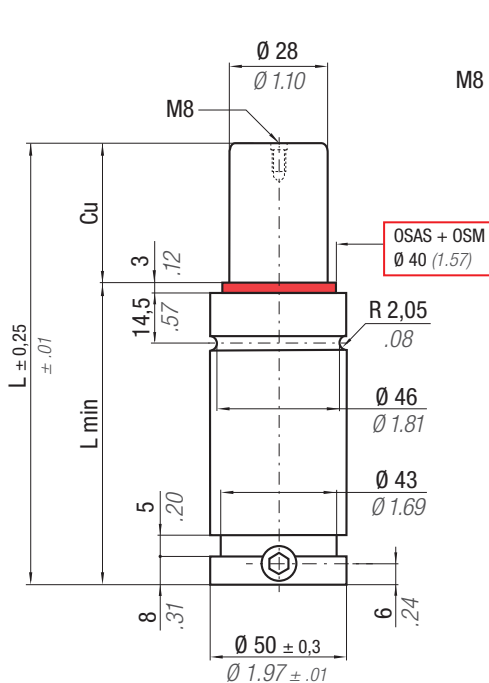

	0 - 80 °C 32 - 176 °F	ΔP ± 0,33 %/°C	P max 170 bar 2465 psi	P min 20 bar 290 psi	S 6,15 cm ² 0,953 in ²	SPM ~ 20 - 100 (at 20°C)	Max Speed 1,8 m/s 70,8 in/s	Maintenance kit 39BMRV01000C
--	--------------------------	---------------------------	------------------------------	----------------------------	----------------------------------------------------	--------------------------------	-----------------------------------	---------------------------------

CODE PHASING OUT from 04/2021	NEW	Cu		L		L min		F ₀		F _{1i} *		F _{1p} **		V ₀		~Kg	~lb	PED 2014/68/EU
		mm	inch	mm	inch	mm	inch	daN	lb	daN	lb	daN	lb	cm ³	in ³			
RV 1200 - 010 - A	♦ RV 1200 - 010 - B	10	0.39	58	2.28	48	1.89	1047 ± 5%	2354	1519	3414	1752	3939	23,7	1.45	0,49	1.08	✓
RV 1200 - 013 - A	♦ RV 1200 - 013 - B	13	0.51	64	2.52	51	2.01			1577	3546	1839	4135	28,4	1.73	0,51	1.12	✓
RV 1200 - 016 - A	RV 1200 - 016 - B	16	0.63	70	2.76	54	2.13			1622	3646	1906	4284	33,1	2.02	0,54	1.19	✓
RV 1200 - 019 - A	RV 1200 - 019 - B	19	0.75	76	2.99	57	2.24			1657	3725	1959	4403	37,7	2.30	0,56	1.23	✓
RV 1200 - 025 - A	RV 1200 - 025 - B	25	0.98	88	3.46	63	2.48			1709	3841	2037	4579	47,1	2.87	0,61	1.34	✓
RV 1200 - 032 - A	RV 1200 - 032 - B	32	1.26	102	4.02	70	2.76			1750	3934	2100	4721	58,0	3.54	0,67	1.48	✓
RV 1200 - 038 - A	RV 1200 - 038 - B	38	1.50	114	4.49	76	2.99			1776	3992	2139	4809	67,4	4.11	0,72	1.59	✓
RV 1200 - 050 - A	RV 1200 - 050 - B	50	1.97	138	5.43	88	3.46			1811	4072	2194	4932	86,1	5.25	0,81	1.79	✓
RV 1200 - 063 - A	RV 1200 - 063 - B	63	2.48	164	6.46	101	3.98			1836	4128	2233	5020	106,3	6.49	0,92	2.03	✓
RV 1200 - 075 - A	RV 1200 - 075 - B	75	2.95	188	7.40	113	4.45			1853	4165	2258	5077	125,0	7.63	1,01	2.23	✓
RV 1200 - 080 - A	RV 1200 - 080 - B	80	3.15	198	7.80	118	4.65	1858	4177	2267	5096	132,8	8.10	1,05	2.31	✓		
RV 1200 - 100 - A	RV 1200 - 100 - B	100	3.94	238	9.37	138	5.43	1875	4215	2293	5156	164,0	10.01	1,21	2.67	✓		
RV 1200 - 125 - A	RV 1200 - 125 - B	125	4.92	288	11.34	163	6.42	1889	4247	2315	5205	202,9	12.38	1,41	3.11	✓		

♦ Disposable

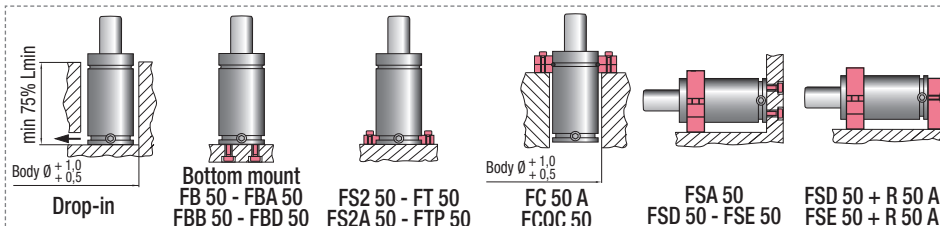

HOW TO ORDER

p. 57

INSTALLATION GUIDELINE

p. 205



ACTIVE SAFETY



OSAS



USAS



OPAS

RV

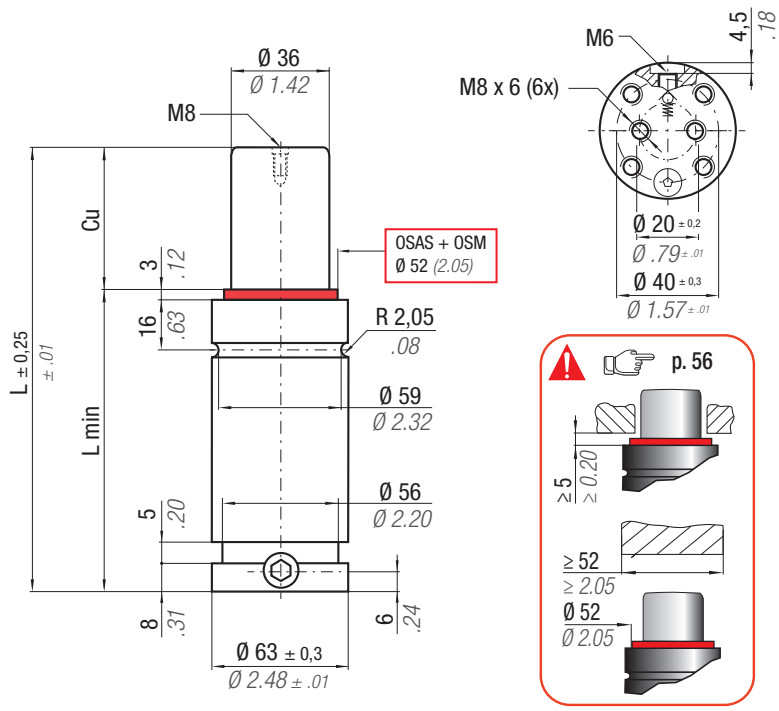

OSAS + OSM = OVER STROKE ACTIVE SAFETY + OVER STROKE MARKER

Il nuovo codice sarà fornito solo ad esaurimento del vecchio
 The new code will be supplied only when the old will be out of stock
 Der neue Kode wird nur angegeben, wenn der alte nicht mehr lieferbar ist
 Le nouveau code sera fourni uniquement lorsque le vieux stock sera écoulé
 El nuevo código será suministrado sólo cuando se agoten las existencias del antiguo guo
 O novo código irá ser fornecido apenas quando o antigo esgotar stock

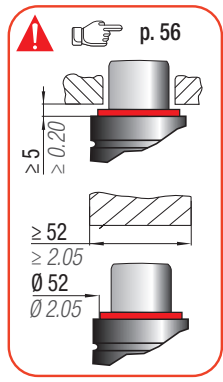

easU MANIFOLD p. 247 p. 262

* F_{1i} = Isothermal end force at 100% Cu p. 16
 ** F_{1p} = Polytrophic end force at 100% Cu

N ₂	0 - 80 °C 32 - 176 °F	ΔP ± 0,33 %/°C	P max 150 bar 2175 psi	P min 20 bar 290 psi	S 10,18 cm ² 1.578 in ²	SPM ~ 20 - 100 (at 20°C)	Max Speed 1,8 m/s 70.8 in/s	Maintenance kit 39BMRV01500C
----------------	--------------------------	---------------------------	------------------------------	----------------------------	-----------------------------------------------------	--------------------------------	-----------------------------------	---------------------------------

CODE PHASING OUT from 04/2021	NEW	Cu		L		L min		F ₀ Initial force		F _{1i} * End force *		F _{1p} ** End force **		V ₀		PED 2014/68/EU		
		mm	inch	mm	inch	mm	inch	daN	lb	daN	lb	daN	lb	cm ³	in ³	~Kg	~lb	✓
RV 1500 - 010 - B	♦ RV 1500 - 010 - C	10	0.39	64	2.52	54	2.13	1530 ± 5%	3440	2089	4697	2424	5448	44	2.69	0,88	1.94	✓
RV 1500 - 013 - B	♦ RV 1500 - 013 - C	13	0.51	70	2.76	57	2.24			2168	4874	2546	5723	52	3.17	0,91	2.01	✓
RV 1500 - 016 - B	RV 1500 - 016 - C	16	0.63	76	2.99	60	2.36			2230	5012	2642	5939	60	3.66	0,96	2.12	✓
RV 1500 - 019 - B	RV 1500 - 019 - C	19	0.75	82	3.23	63	2.48			2279	5123	2720	6114	68	4.15	0,99	2.18	✓
RV 1500 - 025 - B	RV 1500 - 025 - C	25	0.98	94	3.70	69	2.72			2353	5290	2838	6380	84	5.13	1,06	2.34	✓
RV 1500 - 032 - B	RV 1500 - 032 - C	32	1.26	108	4.25	76	2.99			2414	5426	2935	6599	102	6.22	1,14	2.51	✓
RV 1500 - 038 - B	RV 1500 - 038 - C	38	1.50	120	4.72	82	3.23			2452	5512	2997	6738	118	7.20	1,21	2.67	✓
RV 1500 - 050 - B	RV 1500 - 050 - C	50	1.97	144	5.67	94	3.70			2506	5633	3085	6935	149	9.09	1,36	3.00	✓
RV 1500 - 063 - B	RV 1500 - 063 - C	63	2.48	170	6.69	107	4.21			2544	5720	3148	7078	184	11.23	1,52	3.35	✓
RV 1500 - 075 - B	RV 1500 - 075 - C	75	2.95	194	7.64	119	4.69			2570	5777	3190	7172	215	13.12	1,66	3.66	✓
RV 1500 - 080 - B	RV 1500 - 080 - C	80	3.15	204	8.03	124	4.88	2578	5797	3204	7204	229	13.97	1,72	3.79	✓		
RV 1500 - 100 - B	RV 1500 - 100 - C	100	3.94	244	9.61	144	5.67	2605	5857	3249	7303	281	17.15	1,95	4.30	✓		
RV 1500 - 125 - B	RV 1500 - 125 - C	125	4.92	294	11.57	169	6.65	2628	5907	3286	7387	347	21.18	2,24	4.94	✓		

♦ Disposable

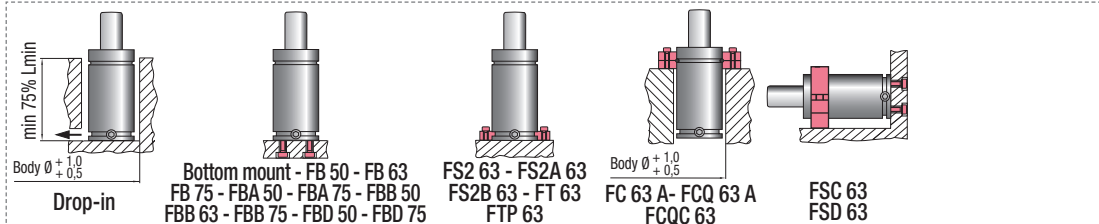

HOW TO ORDER p. 57

INSTALLATION GUIDELINE p. 205

RV 2400

ISO 11901 - 3 B8 3180 220 000 004(MB)	VDI 3003 - Blatt 3 E24.54.815.G (PSA)	B2 4005 (BMW) 39D 997 (VW)	W-DX35-6204 (Ford)
------------------------------------------	------------------------------------------	-------------------------------	--------------------



OSAS + OSM = OVER STROKE ACTIVE SAFETY + OVER STROKE MARKER

ACTIVE SAFETY



OSAS



USAS



OPAS

Il nuovo codice sarà fornito solo ad esaurimento del vecchio
The new code will be supplied only when the old will be out of stock
Der neue Kode wird nur angegeben, wenn der alte nicht mehr lieferbar ist
Le nouveau code sera fourni uniquement lorsque le vieux stock sera écoulé
El nuevo código será suministrado sólo cuando se agoten las existencias del antiguo
O novo código irá ser fornecido apenas quando o antigo esgotar stock

easU MANIFOLD p. 247

p. 262

* F_{1i} =

Isothermal end force at 100% Cu p. 16

** F_{1p} =

Polytropic end force at 100% Cu p. 16

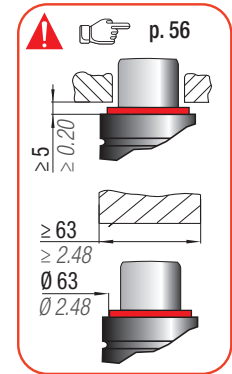
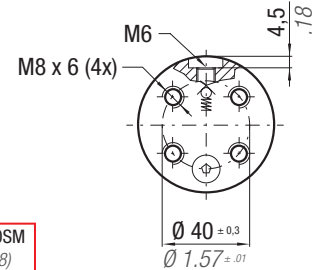
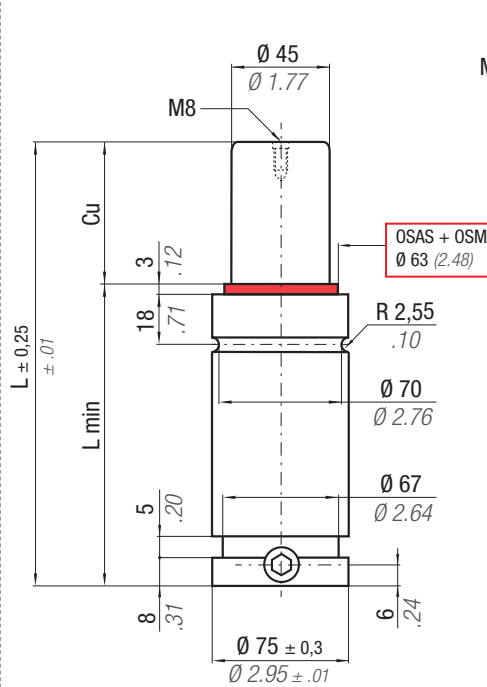

N ₂	0 - 80 °C 32 - 176 °F	ΔP ± 0,33 %/°C	P max 150 bar 2175 psi	P min 20 bar 290 psi	S 15,90 cm ² 2,465 in ²	SPM ~ 20 - 100 (at 20°C)	Max Speed 1,8 m/s 70,8 in/s	Maintenance kit 39BMRV02400D
----------------	--------------------------	---------------------------	------------------------------	----------------------------	-----------------------------------------------------	--------------------------------	-----------------------------------	---------------------------------

CODE PHASING OUT from 04/2021	NEW	Cu		L		L min		F ₀		F _{1i} *		F _{1p} **		V ₀		PED 2014/68/EU			
		mm	inch	mm	inch	mm	inch	daN	lb	daN	lb	daN	lb	cm ³	in ³		~Kg	~lb	
RV 2400 - 010 - A	♦ RV 2400 - 010 - B	10	0.39	65	2.56	55	2.17	2385 ± 5%	5362	3279	7372	3810	8564	68	4.15	1,25	2.76	✓	
RV 2400 - 013 - A	♦ RV 2400 - 013 - B	13	0.51	71	2.80	58	2.28			3409	7663	4010	9015	80	4.88	1,30	2.87	✓	
RV 2400 - 016 - A	♦ RV 2400 - 016 - B	16	0.63	77	3.03	61	2.40			3510	7891	4170	9374	92	5.61	1,35	2.98	✓	
RV 2400 - 019 - A	♦ RV 2400 - 019 - B	19	0.75	83	3.27	64	2.52			3592	8075	4299	9665	104	6.35	1,40	3.09	✓	
RV 2400 - 025 - A	RV 2400 - 025 - B	25	0.98	95	3.74	70	2.76			3716	8354	4498	10111	128	7.81	1,50	3.31	✓	
RV 2400 - 032 - A	RV 2400 - 032 - B	32	1.26	109	4.29	77	3.03			3818	8583	4662	10481	156	9.52	1,61	3.55	✓	
RV 2400 - 038 - A	RV 2400 - 038 - B	38	1.50	121	4.76	83	3.27			150 bar	3883	8728	4767	10717	180	10.98	1,70	3.75	✓
RV 2400 - 050 - A	RV 2400 - 050 - B	50	1.97	145	5.71	95	3.74			2175 psi	3974	8935	4917	11054	228	13.91	1,89	4.17	✓
RV 2400 - 063 - A	RV 2400 - 063 - B	63	2.48	171	6.73	108	4.25			+ 20 °C +68 °F	4041	9083	5026	11299	280	17.09	2,10	4.63	✓
RV 2400 - 075 - A	RV 2400 - 075 - B	75	2.95	195	7.68	120	4.72				4084	9181	5098	11461	328	20.02	2,29	5.05	✓
RV 2400 - 080 - A	RV 2400 - 080 - B	80	3.15	205	8.07	125	4.92	4099	9215		5123	11517	348	21.24	2,37	5.22	✓		
RV 2400 - 100 - A	RV 2400 - 100 - B	100	3.94	245	9.65	145	5.71	4145	9318	5199	11688	428	26.12	2,68	5.91	✓			
RV 2400 - 125 - A	RV 2400 - 125 - B	125	4.92	295	11.61	170	6.69	4183	9405	5264	11833	528	32.22	3,07	6.77	✓			

♦ Disposable

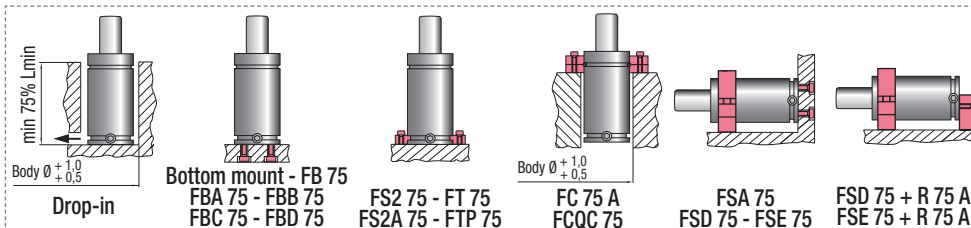

HOW TO ORDER

p. 57

INSTALLATION GUIDELINE

p. 205

ISO 11901 - 3	VDI 3003 - Blatt 3	B2 4005 (BMW)	075.90.60 (FCA)
W-DX35-6204 (Ford)	PG 24D (Mazda)	B8 3180 220 000 004(MB)	E24.54.815.G (PSA)
39D 997 (VW)			



ACTIVE SAFETY



OSAS



USAS



OPAS

RV

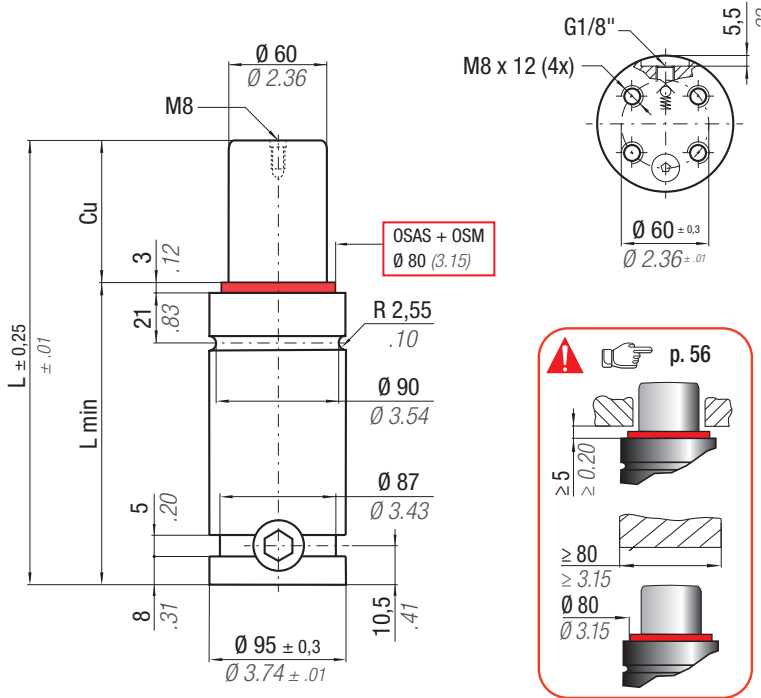

OSAS + OSM = OVER STROKE ACTIVE SAFETY + OVER STROKE MARKER

Il nuovo codice sarà fornito solo ad esaurimento del vecchio

The new code will be supplied only when the old will be out of stock

Der neue Kode wird nur angegeben, wenn der alte nicht mehr lieferbar ist

Le nouveau code sera fourni uniquement lorsque le vieux stock sera écoulé

El nuevo código será suministrado sólo cuando se agoten las existencias del antiguo

O novo código irá ser fornecido apenas quando o antigo esgotar stock

easU MANIFOLD p. 247

p. 262

* F_{1i} =

Isothermal end force at 100% Cu

** F_{1p} =

Polytrophic end force at 100% Cu

N ₂	0 - 80 °C 32 - 176 °F	ΔP ± 0,33 %/°C	P max 150 bar 2175 psi	P min 20 bar 290 psi	S 28,27 cm ² 4.382 in ²	SPM ~ 20 - 100 (at 20°C)	Max Speed 1,8 m/s 70.8 in/s	Maintenance kit 39BMRV04200C
----------------	--------------------------	---------------------------	-------------------------------------	-----------------------------------	------------------------------------------------------------	---------------------------------------	------------------------------------------	----------------------------------------

CODE PHASING OUT from 04/2021	NEW	Cu		L		L min		F ₀ Initial force		F _{1i} * End force *		F _{1p} ** End force **		V ₀		~Kg ~lb		2014/68/EU
		mm	inch	mm	inch	mm	inch	daN	lb	daN	lb	daN	lb	cm ³	in ³			
RV 4200 - 016 - A	◆ RV 4200 - 016 - B	16	0.63	90	3.54	74	2.91	4240 ± 5% 150 bar 2175 psi + 20 °C +68 °F	9532	6103	13720	7197	16179	172	10.50	2,76	6.08	✓
RV 4200 - 019 - A	◆ RV 4200 - 019 - B	19	0.75	96	3.78	77	3.03			6269	14093	7458	16767	192	11.72	2,84	6.26	✓
RV 4200 - 025 - A	RV 4200 - 025 - B	25	0.98	108	4.25	83	3.27			6531	14682	7874	17702	232	14.16	2,99	6.59	✓
RV 4200 - 032 - A	RV 4200 - 032 - B	32	1.26	122	4.80	90	3.54			6755	15186	8236	18515	279	17.03	3,16	6.97	✓
RV 4200 - 038 - A	RV 4200 - 038 - B	38	1.50	134	5.28	96	3.78			6902	15517	8475	19052	320	19.53	3,31	7.30	✓
RV 4200 - 050 - A	RV 4200 - 050 - B	50	1.97	158	6.22	108	4.25			7117	16001	8827	19844	401	24.47	3,61	7.96	✓
RV 4200 - 063 - A	RV 4200 - 063 - B	63	2.48	184	7.24	121	4.76			7278	16361	9092	20440	488	29.78	3,94	8.69	✓
RV 4200 - 075 - A	RV 4200 - 075 - B	75	2.95	208	8.19	133	5.24			7386	16604	9272	20843	569	34.72	4,24	9.35	✓
RV 4200 - 080 - A	RV 4200 - 080 - B	80	3.15	218	8.58	138	5.43			7423	16687	9333	20982	603	36.80	4,36	9.61	✓
RV 4200 - 100 - A	RV 4200 - 100 - B	100	3.94	258	10.16	158	6.22			7539	16949	9529	21421	738	45.04	4,86	10.71	✓
RV 4200 - 125 - A	RV 4200 - 125 - B	125	4.92	308	12.13	183	7.20	7639	17173	9696	21798	906	55.29	5,48	12.08	✓		

◆ Disposable

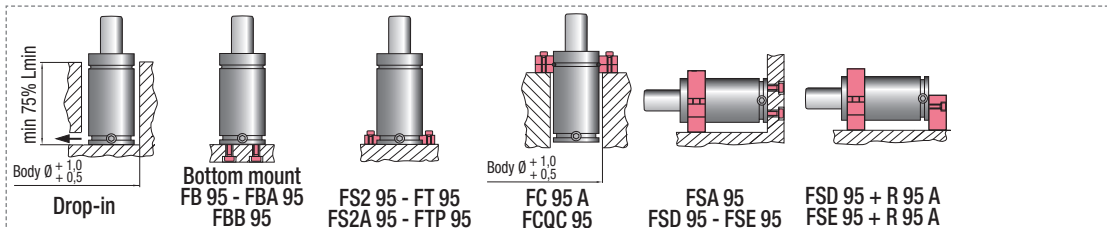

HOW TO ORDER

p. 57

INSTALLATION GUIDELINE

p. 205

ISO 11901 - 3	VDI 3003 - Blatt 3	B2 4005 (BMW)	075.90.60 (FCA)
W-DX35-6204 (Ford)	B8 3180 220 000 004(MB)	39D 997 (VW)	



OSAS + OSM = OVER STROKE ACTIVE SAFETY + OVER STROKE MARKER

ACTIVE SAFETY

Il nuovo codice sarà fornito solo ad esaurimento del vecchio

The new code will be supplied only when the old will be out of stock

Der neue Kode wird nur angegeben, wenn der alte nicht mehr lieferbar ist

Le nouveau code sera fourni uniquement lorsque le vieux stock sera épuisé

El nuevo código será suministrado sólo cuando se agoten las existencias del antiguo

O novo código irá ser fornecido apenas quando o antigo esgotar stock



OSAS



USAS



OPAS

easU MANIFOLD p. 247

p. 262

* F_{1i} = Isothermal end force at 100% Cu p. 16

** F_{1p} = Polytrophic end force at 100% Cu

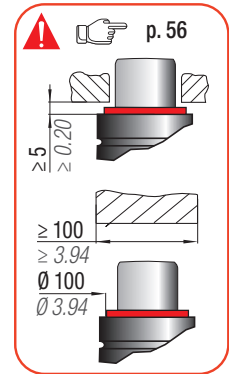
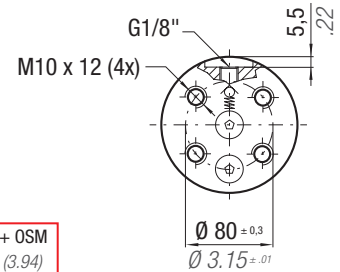
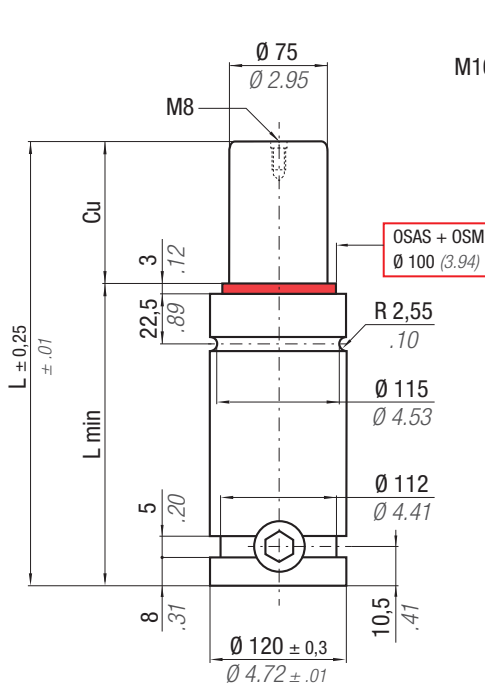

N ₂	0 - 80 °C 32 - 176 °F	ΔP ± 0,33 %/°C	P max 150 bar 2175 psi	P min 20 bar 290 psi	S 44,18 cm ² 6.848 in ²	SPM ~ 20 - 100 (at 20°C)	Max Speed 1,8 m/s 70.8 in/s	Maintenance kit 39BMRV06600C
----------------	--------------------------	---------------------------	------------------------------	----------------------------	-----------------------------------------------------	--------------------------------	-----------------------------------	---------------------------------

CODE PHASING OUT from 04/2021	NEW	Cu		L		L min		F ₀ Initial force		F _{1i} * End force *		F _{1p} ** End force **		V ₀		PED 2014/68/EU		
		mm	inch	mm	inch	mm	inch	daN	lb	daN	lb	daN	lb	cm ³	in ³		~Kg	~lb
RV 6600 - 016 - A	♦ RV 6600 - 016 - B	16	0.63	100	3.94	84	3.31	6630 ± 5% 14904 150 bar 2175 psi + 20 °C +68 °F		9141	20550	10631	23900	298	18.19	5,12	11.29	✓
RV 6600 - 019 - A	♦ RV 6600 - 019 - B	19	0.75	106	4.17	87	3.43			9393	21115	11022	24777	330	20.14	5,23	11.53	✓
RV 6600 - 025 - A	RV 6600 - 025 - B	25	0.98	118	4.65	93	3.66			9799	22028	11658	26209	394	24.04	5,47	12.06	✓
RV 6600 - 032 - A	RV 6600 - 032 - B	32	1.26	132	5.20	100	3.94			10157	22834	12228	27490	469	28.62	5,75	12.68	✓
RV 6600 - 038 - A	RV 6600 - 038 - B	38	1.50	144	5.67	106	4.17			10397	23374	12614	28357	533	32.53	5,99	13.21	✓
RV 6600 - 050 - A	RV 6600 - 050 - B	50	1.97	168	6.61	118	4.65			10757	24183	13196	29666	661	40.34	6,47	14.26	✓
RV 6600 - 063 - A	RV 6600 - 063 - B	63	2.48	194	7.64	131	5.16			11031	24799	13645	30675	799	48.76	6,99	15.41	✓
RV 6600 - 075 - A	RV 6600 - 075 - B	75	2.95	218	8.58	143	5.63			11219	25221	13954	31369	927	56.57	7,47	16.47	✓
RV 6600 - 080 - A	RV 6600 - 080 - B	80	3.15	228	8.98	148	5.83			11284	25367	14061	31611	980	59.80	7,67	16.91	✓
RV 6600 - 100 - A	RV 6600 - 100 - B	100	3.94	268	10.55	168	6.61			11490	25832	14404	32381	1193	72.80	8,46	18.65	✓
RV 6600 - 125 - A	RV 6600 - 125 - B	125	4.92	318	12.52	193	7.60	11669	26234	14703	33053	1459	89.03	9,46	20.86	✓		

♦ Disposable

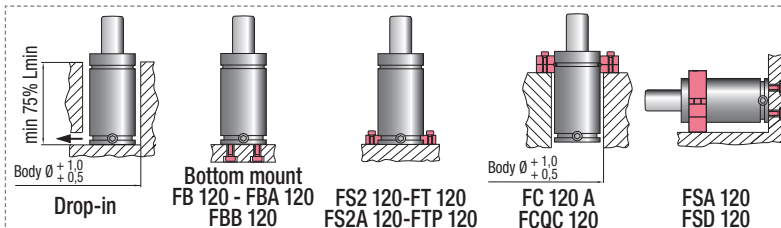

HOW TO ORDER

p. 57

INSTALLATION GUIDELINE

p. 205

ISO 11901 - 3 W-DX35-6204 (Ford)	VDI 3003 - Blatt 3 PG 24D (Mazda)	B2 4005 (BMW) B8 3180 220 000 004(MB)	075.90.60 (FCA) 39D 997 (VW)
-------------------------------------	--------------------------------------	------------------------------------------	---------------------------------



ACTIVE SAFETY



OSAS



USAS



OPAS

RV

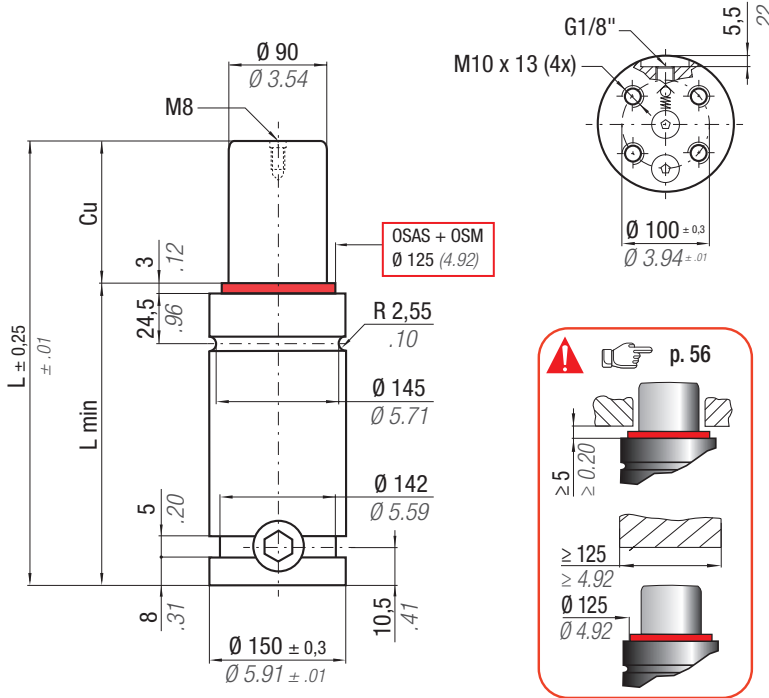

OSAS + OSM = OVER STROKE ACTIVE SAFETY + OVER STROKE MARKER

Il nuovo codice sarà fornito solo ad esaurimento del vecchio

The new code will be supplied only when the old will be out of stock

Der neue Kode wird nur angegeben, wenn der alte nicht mehr lieferbar ist

Le nouveau code sera fourni uniquement lorsque le vieux stock sera écoulé

El nuevo código será suministrado sólo cuando se agoten las existencias del antiguo

O novo código irá ser fornecido apenas quando o antigo esgotar stock

easU MANIFOLD p. 247

p. 262

* $F_{1i} =$

Isothermal end force at 100% Cu

p. 16

** $F_{1p} =$

Polytropic end force at 100% Cu

		0 - 80 °C 32 - 176 °F	ΔP ± 0,33 %/°C	P max 150 bar 2175 psi	P min 20 bar 290 psi	S 63,62 cm ² 9.864 in ²	SPM ~ 20 - 80 (at 20°C)	Max Speed 1,8 m/s 70.8 in/s	Maintenance kit 39BMRV09500C
CODE PHASING OUT from 04/2021	NEW	Cu	L	L min	F0	F1i *	F1p **	V0	
		mm inch	mm inch	mm inch	daN lb	daN lb	daN lb	cm ³ in ³	-Kg -lb
RV 9500 - 019 - A	RV 9500 - 019 - B	19 0.75	116 4.57	97 3.82	9540 21446 ± 5% 150 bar 2175 psi + 20 °C +68 °F	13135 29528	15265 34318	513 31.31	9,56 21.08
RV 9500 - 025 - A	RV 9500 - 025 - B	25 0.98	128 5.04	103 4.06		13676 30744	16105 36206	609 37.16	9,93 21.89
RV 9500 - 032 - A	RV 9500 - 032 - B	32 1.26	142 5.59	110 4.33		14156 31825	16862 37906	722 44.06	10,37 22.86
RV 9500 - 038 - A	RV 9500 - 038 - B	38 1.50	154 6.06	116 4.57		14480 32553	17376 39062	818 49.92	10,74 23.68
RV 9500 - 050 - A	RV 9500 - 050 - B	50 1.97	178 7.01	128 5.04		14967 33648	18156 40815	1010 61.63	11,49 25.33
RV 9500 - 063 - A	RV 9500 - 063 - B	63 2.48	204 8.03	141 5.55		15341 34487	18759 42173	1218 74.33	12,30 27.12
RV 9500 - 075 - A	RV 9500 - 075 - B	75 2.95	228 8.98	153 6.02		15597 35063	19177 43111	1411 86.10	13,05 28.77
RV 9500 - 080 - A	RV 9500 - 080 - B	80 3.15	238 9.37	158 6.22		15686 35264	19322 43439	1491 90.99	13,37 29.48
RV 9500 - 100 - A	RV 9500 - 100 - B	100 3.94	278 10.94	178 7.01		15970 35901	19788 44485	1811 110.51	14,61 32.21
RV 9500 - 125 - A	RV 9500 - 125 - B	125 4.92	328 12.91	203 7.99		16216 36455	20194 45398	2212 134.98	16,18 35.67

◆ Disposable

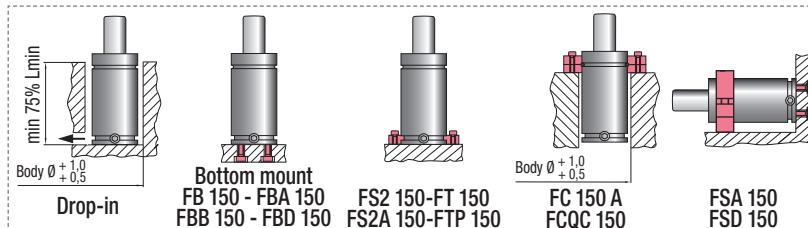

HOW TO ORDER

p. 57

INSTALLATION GUIDELINE

p. 205



OSAS + OSM = OVER STROKE ACTIVE SAFETY + OVER STROKE MARKER

ACTIVE SAFETY

Il nuovo codice sarà fornito solo ad esaurimento del vecchio

The new code will be supplied only when the old will be out of stock

Der neue Kode wird nur angegeben, wenn der alte nicht mehr lieferbar ist

Le nouveau code sera fourni uniquement lorsque le vieux stock sera écoulé

El nuevo código será suministrado sólo cuando se agoten las existencias del antiguo

O novo código irá ser fornecido apenas quando o antigo esgotar stock



OSAS



USAS



OPAS

easu MANIFOLD p. 247

p. 262

* F_{1i} = Isothermal end force at 100% Cu p. 16

** F_{1p} = Polytropic end force at 100% Cu

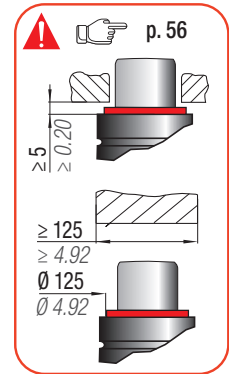
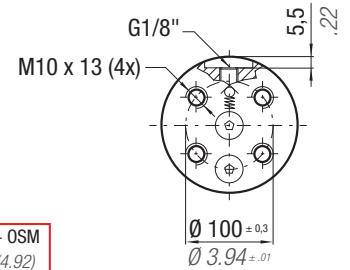
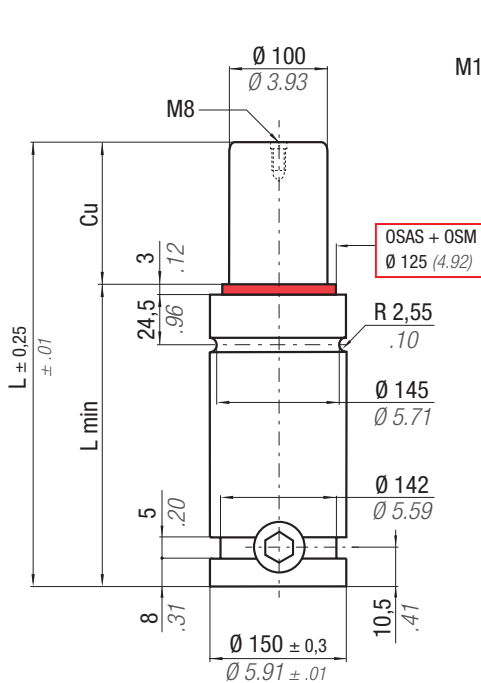

N₂		0 - 80 °C 32 - 176 °F	ΔP ± 0,33 %/°C	P max 150 bar 2175 psi	P min 20 bar 290 psi	S 78,54 cm ² 12.173 in ²	SPM ~ 20 - 80 (at 20°C)	Max Speed 1,8 m/s 70.8 in/s	Maintenance kit 39BMRV12000A	
CODE PHASING OUT from 04/2021	NEW	Cu	L	L min	F ₀	F _{1i} *	F _{1p} **	V ₀		
RV 12000 - 019 - A	♦ RV 12000 - 019 - B	19 0.75	116 4.57	97 3.82	11780 26470 ± 5% 150 bar 2175 psi + 20 °C +68 °F	16936 38075	19966 44886	568 34.66	9,34 20.59	✓
RV 12000 - 025 - A	RV 12000 - 025 - B	25 0.98	128 5.04	103 4.06		17789 39991	21311 47910	671 40.95	9,73 21.45	✓
RV 12000 - 032 - A	RV 12000 - 032 - B	32 1.26	142 5.59	110 4.33		18565 41737	22555 50706	791 48.27	10,18 22.44	✓
RV 12000 - 038 - A	RV 12000 - 038 - B	38 1.50	154 6.06	116 4.57		19098 42935	23419 52648	894 54.56	10,57 23.30	✓
RV 12000 - 050 - A	RV 12000 - 050 - B	50 1.97	178 7.01	128 5.04		19916 44772	24759 55659	1101 67.19	11,35 25.02	✓
RV 12000 - 063 - A	RV 12000 - 063 - B	63 2.48	204 8.03	141 5.55		20555 46210	25820 58045	1324 80.80	12,20 26.90	✓
RV 12000 - 075 - A	RV 12000 - 075 - B	75 2.95	228 8.98	153 6.02		21001 47212	26566 59723	1531 93.43	12,97 28.59	✓
RV 12000 - 080 - A	RV 12000 - 080 - B	80 3.15	238 9.37	158 6.22		21157 47563	26829 60314	1617 98.68	13,30 29.32	✓
RV 12000 - 100 - A	RV 12000 - 100 - B	100 3.94	278 10.94	178 7.01		21659 48692	27677 62221	1961 119.67	14,60 32.19	✓
RV 12000 - 125 - A	RV 12000 - 125 - B	125 4.92	328 12.91	203 7.99		22101 49685	28430 63912	2391 145.91	16,22 35.76	✓

♦ Disposable

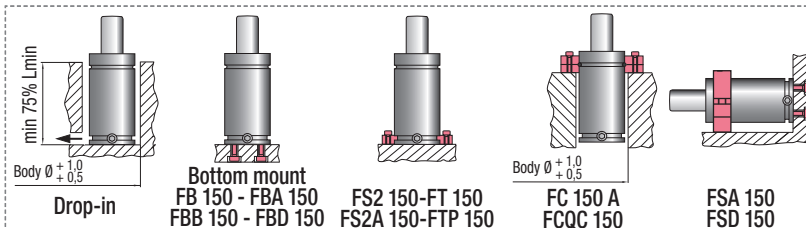

HOW TO ORDER
 p. 57

INSTALLATION GUIDELINE
 p. 205

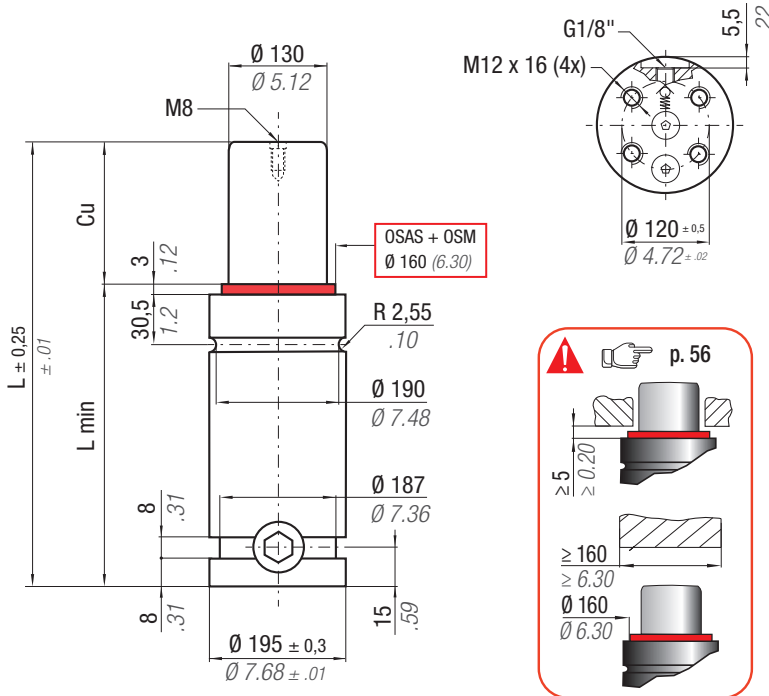

OSAS + OSM = OVER STROKE ACTIVE SAFETY + OVER STROKE MARKER



ACTIVE SAFETY



OSAS



USAS



OPAS

Il nuovo codice sarà fornito solo ad esaurimento del vecchio

The new code will be supplied only when the old will be out of stock

Der neue Kode wird nur angegeben, wenn der alte nicht mehr lieferbar ist

Le nouveau code sera fourni uniquement lorsque le vieux stock sera écoulé

El nuevo código será suministrado sólo cuando se agoten las existencias del antiguo

O novo código irá ser fornecido apenas quando o antigo esgotar stock

easu MANIFOLD p. 247

p. 262

* F_{1i} =

Isothermal end force at 100% Cu

p. 16

** F_{1p} =

Polytrophic end force at 100% Cu

p. 16

RV

N ₂		0 - 80 °C 32 - 176 °F	ΔP ± 0,33 %/°C	P max 150 bar 2175 psi	P min 20 bar 290 psi	S 132,73 cm ² 20.573 in ²	SPM ~ 20 - 80 (at 20°C)	Max Speed 1,8 m/s 70.8 in/s	Maintenance kit 39BMRV20000A
CODE PHASING OUT from 04/2021	NEW	Cu	L	L min	F ₀ Initial force	F _{1i} * End force *	F _{1p} ** End force **	V ₀	PED 2014/68/EU
		mm inch	mm inch	mm inch	daN lb	daN lb	daN lb	cm ³ in ³	-Kg -lb
RV 20000 - 019 - A	◆ RV 20000 - 019 - B	19 0.75	148 5.83	129 5.08	19910 44738 ± 5% 150 bar 2175 psi + 20 °C +68 °F	27636 62128	32207 72404	1047 63.89	21,58 47.58
RV 20000 - 025 - A	◆ RV 20000 - 025 - B	25 0.98	160 6.30	135 5.32		29099 65417	34490 77537	1215 74.14	22,29 49.14
RV 20000 - 032 - A	RV 20000 - 032 - B	32 1.26	174 6.85	142 5.59		30485 68532	36688 82478	1411 86.10	23,12 50.97
RV 20000 - 038 - A	RV 20000 - 038 - B	38 1.50	186 7.32	148 5.83		31467 70740	38266 86025	1580 96.42	23,84 52.56
RV 20000 - 050 - A	RV 20000 - 050 - B	50 1.97	210 8.27	160 6.30		33024 74242	40801 91724	1916 116.92	25,26 55.69
RV 20000 - 063 - A	RV 20000 - 063 - B	63 2.48	236 9.29	173 6.81		34290 77086	42889 96418	2280 139.13	26,80 59.08
RV 20000 - 075 - A	RV 20000 - 075 - B	75 2.95	260 10.24	185 7.28		35196 79124	44401 99818	2617 159.70	28,22 62.21
RV 20000 - 080 - A	RV 20000 - 080 - B	80 3.15	270 10.63	190 7.48		35519 79850	44943 101035	2757 168.24	28,81 63.52
RV 20000 - 100 - A	RV 20000 - 100 - B	100 3.94	310 12.21	210 8.27		36574 82222	46724 105039	3317 202.42	31,19 68.76
RV 20000 - 125 - A	RV 20000 - 125 - B	125 4.92	360 14.17	235 9.25		37526 84361	48345 108683	4018 245.19	34,16 75.31

◆ Disposable

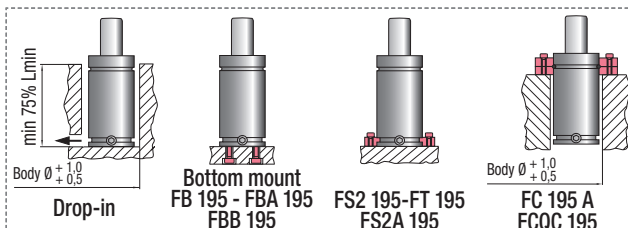

HOW TO ORDER

p. 57

INSTALLATION GUIDELINE

p. 205

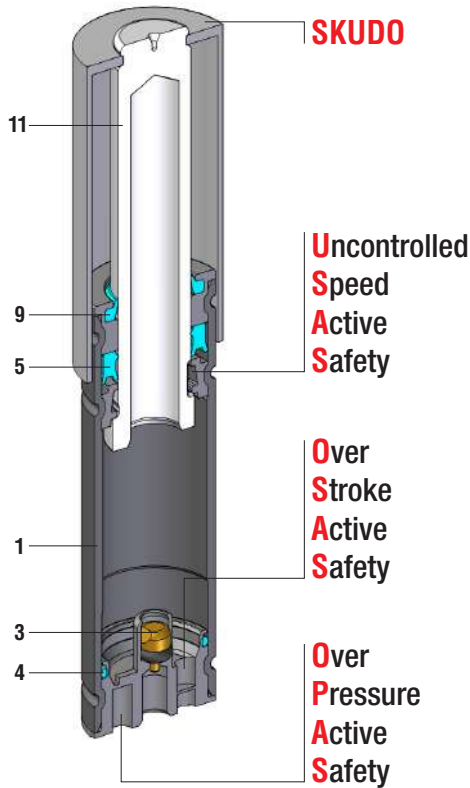

RS 170 - RS 320

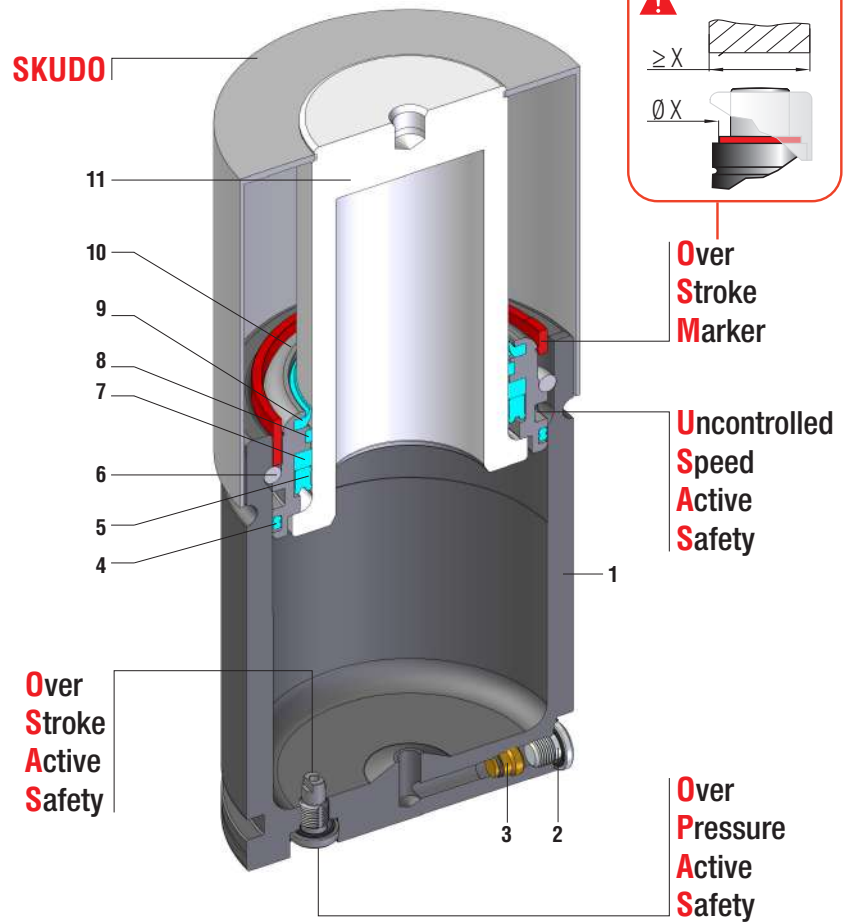

RS 350 ÷ RS 9500

Minima altezza, massima forza + SKUDO - Minimum height, maximum force + SKUDO - Minimale Höhe, maximale Kraft + SKUDO
 Hauteur minimale, force maximale + SKUDO - Mínima altura, máxima fuerza + SKUDO - Altura mínima, força máxima + SKUDO

SEALING	ROD SEAL
DESIGN	BUSH - BODY DESIGN

1	Body	5	Rod seal	9	Rod wiper
2	Plug	6	Retaining ring	10	Bush
3	Valve	7	Back-up ring	11	Rod (nitrited superfinished)
4	Dual ring seal	8	Guide ring		

RANGE CHART

Model	Body Ø		Stroke Cu		Initial force F0						
	mm	inch	mm	inch	daN	lb					
RS 170	19	0.75	7 - 122	0.28 - 4.80	170	382	✓	✓	✓	✓	-
RS 320	25	0.98	7 - 122	0.28 - 4.80	320	719	✓	✓	✓	✓	-
RS 350	32	1.26	7 - 122	0.28 - 4.80	360	809	✓	✓	✓	✓	✓
RS 500	38	1.50	7 - 122	0.28 - 4.80	470	1057	✓	✓	✓	✓	✓
RS 750	45	1.77	7 - 122	0.28 - 4.80	740	1664	✓	✓	✓	✓	✓
RS 1000	50	1.97	10 - 122	0.39 - 4.80	920	2068	✓	✓	✓	✓	✓
RS 1200	50	1.97	10 - 122	0.39 - 4.80	1047	2354	✓	✓	✓	✓	✓
RS 1500	63	2.48	10 - 122	0.39 - 4.80	1530	3440	✓	✓	✓	✓	✓
RS 2400	75	2.95	13 - 122	0.51 - 4.80	2385	5362	✓	✓	✓	✓	✓
RS 4200	95	3.74	13 - 122	0.51 - 4.80	4240	9532	✓	✓	✓	✓	✓
RS 6600	120	4.72	13 - 122	0.51 - 4.80	6630	14905	✓	✓	✓	✓	✓
RS 9500	150	5.91	16 - 122	0.63 - 4.80	9540	21447	✓	✓	✓	✓	✓

✓ Built-in as standard

✓ Optional upon request

HOW TO ORDER

Series _____ Revision code _____

Model **RS1000-060-B-E-W**

Stroke _____ Version _____

Available versions

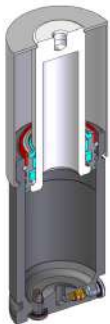

RS 1000-060-B
Standard code



Self contained

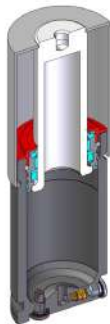

RS 1000-060-B-W
Add "-W" to standard code



Self contained



+
Secondary wiper

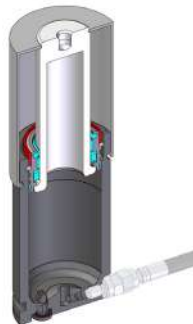

RS 1000-060-B-N
Add "-N" to standard code



Linkable

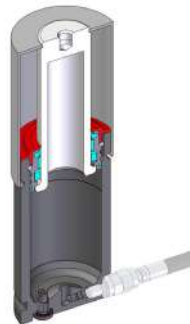

RS 1000-060-B-N-W
Add "-N-W" to standard code



Linkable



+
Secondary wiper



RS 1000-060-B-E
Add "-E" to standard code



Easy
Manifold

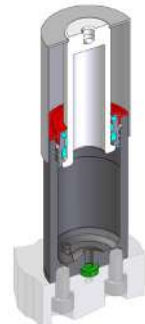

RS 1000-060-B-E-W
Add "-E-W" to standard code



Easy
Manifold



+
Secondary wiper

Il nuovo codice sarà fornito solo ad esaurimento del vecchio - The new code will be supplied only when the old will be out of stock - Der neue Kode wird nur angegeben, wenn der alte nicht mehr lieferbar ist - Le nouveau code sera fourni uniquement lorsque le vieux stock sera écoulé - El nuevo código será suministrado sólo cuando se agoten las existencias del antiguo - O novo código irá ser fornecido apenas quando o antigo esgotar stock

ACTIVE SAFETY



OSAS



USAS



OPAS



SKUDO

eASU MANIFOLD p. 247

SKUDO p. 262

* $F_{1i} =$

Isothermal end force at 100% Cu p. 16

** $F_{1p} =$

Polytropic end force at 100% Cu

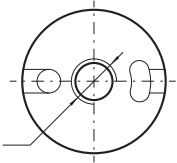
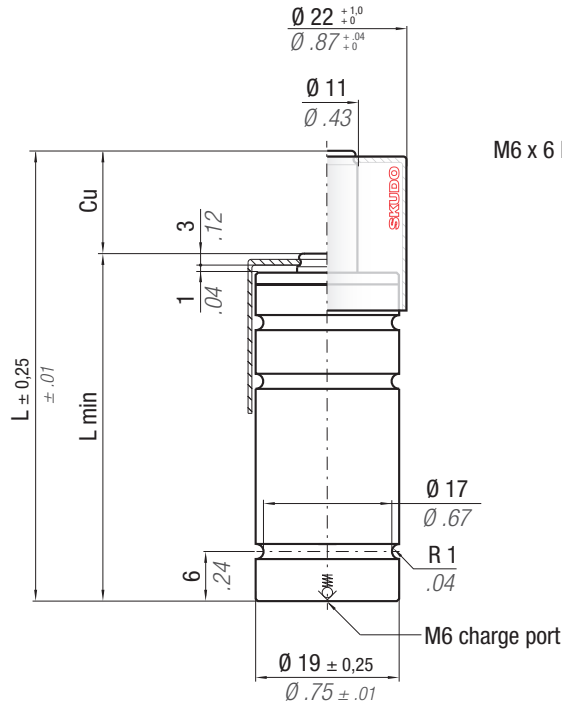

M6 x 6 Max

Ø 17

Ø .67

R 1

.04

M6 charge port

Ø 19 ± 0.25

Ø .75 ± .01

	N₂		0 - 80 °C 32 - 176 °F	ΔP	± 0,33 %/°C	P max	180 bar 2610 psi	P min	20 bar 290 psi	S	0,95 cm ² 0,147 in ²	SPM	~ 40 - 100 (at 20°C)	Max Speed	1,8 m/s 70,8 in/s	Maintenance kit	Disposable
--	----------------------	--	--------------------------	-----------	-------------	--------------	---------------------	--------------	-------------------	----------	-----------------------------------------------	------------	-------------------------	------------------	----------------------	------------------------	------------

CODE PHASING OUT from 05/2019	NEW	Cu		L		L min		F ₀		F _{1i} *		F _{1p} **		V ₀		~Kg ~lb		
		mm	inch	mm	inch	mm	inch	daN	lb	daN	lb	daN	lb	cm ³	in ³			
RS 170 - 007 - B	RS 170 - 007 - C	7	0.28	50	1.97	43	1.69	170 ± 5%	382	239	537	270	607	2,9	0.17	0,06	0.13	✓
RS 170 - 010 - B	RS 170 - 010 - C	10	0.39	56	2.20	46	1.81			253	568	290	652	3,6	0.22	0,07	0.14	✓
RS 170 - 012 - B	RS 170 - 012 - C	12	0.47	60	2.36	48	1.89			260	584	300	674	4,0	0.25	0,07	0.15	✓
RS 170 - 016 - B	RS 170 - 016 - C	16	0.63	68	2.68	52	2.05			270	607	315	709	5,0	0.30	0,07	0.16	✓
RS 170 - 022 - B	RS 170 - 022 - C	22	0.87	80	3.15	58	2.28			281	632	331	744	6,4	0.39	0,08	0.17	✓
RS 170 - 029 - B	RS 170 - 029 - C	29	1.14	94	3.70	65	2.56			289	650	343	771	8,1	0.49	0,09	0.19	✓
RS 170 - 035 - B	RS 170 - 035 - C	35	1.38	106	4.17	71	2.80			294	662	350	788	9,5	0.58	0,09	0.21	✓
RS 170 - 047 - B	RS 170 - 047 - C	47	1.85	130	5.12	83	3.27			301	677	360	810	12,4	0.76	0,11	0.24	✓
RS 170 - 060 - B	RS 170 - 060 - C	60	2.36	156	6.14	96	3.78			306	687	367	826	15,5	0.94	0,12	0.27	✓
RS 170 - 072 - B	RS 170 - 072 - C	72	2.83	185	7.28	113	4.45			306	688	368	827	18,5	1.13	0,14	0.31	✓
RS 170 - 077 - B	RS 170 - 077 - C	77	3.03	195	7.68	118	4.65	307	690	370	831	19,7	1.20	0,15	0.32	✓		
RS 170 - 097 - B	RS 170 - 097 - C	97	3.82	235	9.25	138	5.43	311	698	375	843	24,5	1.49	0,17	0.37	✓		
RS 170 - 122 - B	RS 170 - 122 - C	122	4.80	285	11.22	163	6.42	313	704	379	852	30,4	1.86	0,19	0.43	✓		

WARNING REMOVE SKUDO

Upside down mounting

Drop-in

Bottom mount

FC 19 B
FCC 19 A

FS3 19

NOT FOR

HOW TO ORDER

p. 73

INSTALLATION GUIDELINE

p. 205

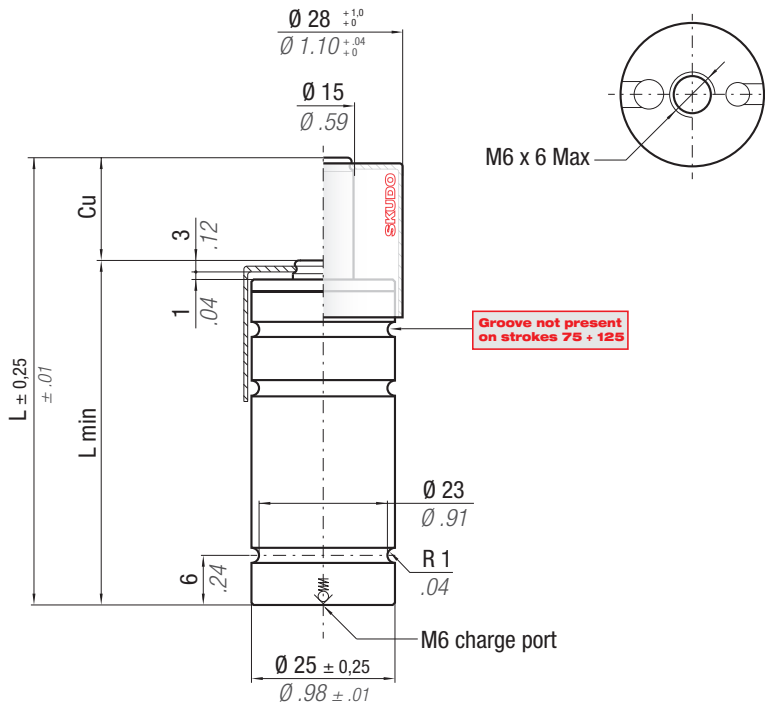

Il nuovo codice sarà fornito solo ad esaurimento del vecchio

The new code will be supplied only when the old will be out of stock

Der neue Kode wird nur angegeben, wenn der alte nicht mehr lieferbar ist

Le nouveau code sera fourni uniquement lorsque le vieux stock sera écoulé

El nuevo código será suministrado sólo cuando se agoten las existencias del antiguo

O novo código irá ser fornecido apenas quando o antigo esgotar stock



* $F_{1i} =$

Isothermal end force at 100% Cu

Hand icon p. 16

** $F_{1p} =$

Polytrophic end force at 100% Cu

Hand icon

ACTIVE SAFETY



OSAS



USAS



OPAS



SKUDO

RS

N ₂		0 - 80 °C 32 - 176 °F	ΔP ± 0,33 %/°C	P max 180 bar 2610 psi	P min 20 bar 290 psi	S 1,77 cm ² 0.27 in ²	SPM ~ 40 - 100 (at 20°C)	Max Speed 1,8 m/s 70.8 in/s	Maintenance kit Disposable
CODE	NEW	Cu	L	L min	F ₀	F _{1i} *	F _{1p} **	V ₀	PED
PHASING OUT from 01/2020		mm inch	mm inch	mm inch	Initial force daN lb	End force * daN lb	End force ** daN lb	cm ³ in ³	~Kg ~lb
RS 320 - 007 - B	RS 320 - 007 - C	7 0.28	50 1.97	43 1.69	320 719 ± 5%	438 985	494 1110	5,5 0.34	0,10 0.23
RS 320 - 010 - B	RS 320 - 010 - C	10 0.39	56 2.20	46 1.81		463 1041	529 1188	6,9 0.42	0,11 0.24
RS 320 - 012 - B	RS 320 - 012 - C	12 0.47	60 2.36	48 1.89		475 1069	547 1229	7,8 0.47	0,11 0.25
RS 320 - 016 - B	RS 320 - 016 - C	16 0.63	68 2.68	52 2.05		495 1112	574 1291	9,6 0.58	0,12 0.26
RS 320 - 022 - B	RS 320 - 022 - C	22 0.87	80 3.15	58 2.28		514 1155	603 1355	12,3 0.75	0,13 0.29
RS 320 - 029 - B	RS 320 - 029 - C	29 1.14	94 3.70	65 2.56		529 1189	625 1404	15,5 0.94	0,14 0.31
RS 320 - 035 - B	RS 320 - 035 - C	35 1.38	106 4.17	71 2.80		538 1209	638 1434	18,2 1.11	0,15 0.33
RS 320 - 047 - B	RS 320 - 047 - C	47 1.85	130 5.12	83 3.27		550 1237	656 1475	23,6 1.44	0,17 0.38
RS 320 - 060 - B	RS 320 - 060 - C	60 2.36	156 6.14	96 3.78		559 1256	669 1503	29,5 1.80	0,19 0.43
RS 320 - 072 - B	RS 320 - 072 - C	72 2.83	185 7.28	113 4.45		557 1252	667 1498	35,5 2.17	0,22 0.48
RS 320 - 077 - B	RS 320 - 077 - C	77 3.03	195 7.68	118 4.65	559 1257	670 1506	37,7 2.30	0,23 0.50	
RS 320 - 097 - B	RS 320 - 097 - C	97 3.82	235 9.25	138 5.43	566 1272	680 1528	46,8 2.85	0,26 0.57	
RS 320 - 122 - B	RS 320 - 122 - C	122 4.80	285 11.22	163 6.42	571 1284	688 1546	58,1 3.54	0,30 0.66	

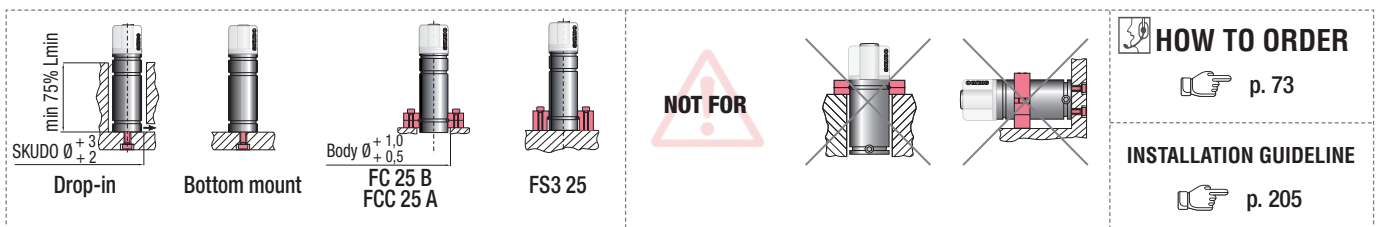
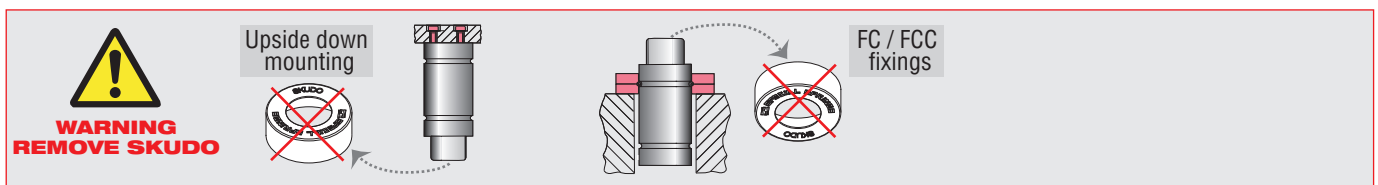

HOW TO ORDER

Hand icon p. 73

INSTALLATION GUIDELINE

Hand icon p. 205



OSAS + OSM = **OVER STROKE ACTIVE SAFETY** + **OVER STROKE MARKER**

ACTIVE SAFETY



OSAS



USAS



OPAS



SKUDO

Il nuovo codice sarà fornito solo ad esaurimento del vecchio

The new code will be supplied only when the old will be out of stock

Der neue Kode wird nur angegeben, wenn der alte nicht mehr lieferbar ist

Le nouveau code sera fourni uniquement lorsque le vieux stock sera écolé

El nuevo código será suministrado sólo cuando se agoten las existencias del antiguo

O novo código irá ser fornecido apenas quando o antigo esgotar stock

easyl MANIFOLD p. 247

p. 262

* F_{1i} =

Isothermal end force at 100% Cu



p. 16

** F_{1p} =

Polytropic end force at 100% Cu

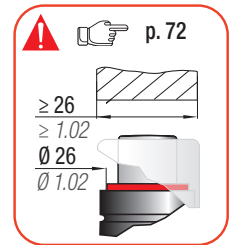
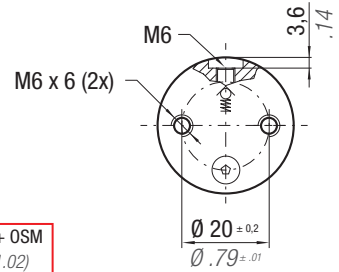
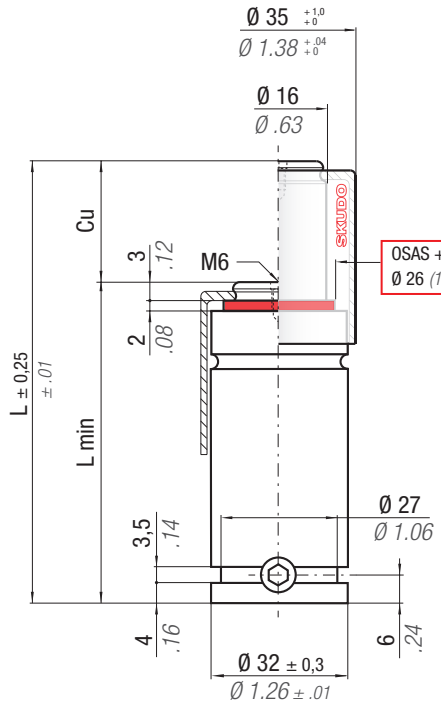

N₂	0 - 80 °C 32 - 176 °F	ΔP ± 0,33 %/°C	P max 180 bar 2610 psi	P min 20 bar 290 psi	S 2,01 cm ² 0,312 in ²	SPM ~ 20 - 100 (at 20°C)	Max Speed 1,8 m/s 70,8 in/s	Maintenance kit 39BMRV00350C
----------------------	--------------------------	---------------------------	-------------------------------------	-----------------------------------	-----------------------------------------------------------	---------------------------------------	------------------------------------------	----------------------------------------

CODE PHASING OUT from 04/2021	NEW	Cu		L		L min		F ₀		F _{1i} *		F _{1p} **		V ₀		~Kg	~lb	PED 2014/68/EU								
		mm	inch	mm	inch	mm	inch	daN	lb	daN	lb	daN	lb	cm ³	in ³											
RS 350 - 007 - A	◆ RS 350 - 007 - B	7	0.28	50	1.97	43	1.69	360 809 ± 5% 180 bar 2610 psi + 20 °C +68 °F	484	1088	541	1216	6,9	0.42	0,16	0.36	✓									
RS 350 - 010 - A	◆ RS 350 - 010 - B	10	0.39	56	2.20	46	1.81											506	1137	572	1285	8,6	0.52	0,17	0.38	✓
RS 350 - 013 - A	RS 350 - 013 - B	13	0.51	62	2.44	49	1.93											521	1172	594	1334	10,4	0.63	0,18	0.40	✓
RS 350 - 016 - A	RS 350 - 016 - B	16	0.63	68	2.68	52	2.05											533	1198	610	1371	12,2	0.74	0,19	0.42	✓
RS 350 - 022 - A	RS 350 - 022 - B	22	0.87	80	3.15	58	2.28											549	1233	633	1423	15,8	0.96	0,21	0.46	✓
RS 350 - 029 - A	RS 350 - 029 - B	29	1.14	94	3.70	65	2.56											560	1260	650	1461	19,9	1.21	0,23	0.51	✓
RS 350 - 035 - A	RS 350 - 035 - B	35	1.38	106	4.17	71	2.80											567	1276	660	1484	23,5	1.43	0,25	0.55	✓
RS 350 - 047 - A	RS 350 - 047 - B	47	1.85	130	5.12	83	3.27											577	1297	674	1515	30,6	1.87	0,29	0.63	✓
RS 350 - 060 - A	RS 350 - 060 - B	60	2.36	156	6.14	96	3.78											583	1311	683	1536	38,3	2.34	0,33	0.72	✓
RS 350 - 072 - A	RS 350 - 072 - B	72	2.83	180	7.09	108	4.25											587	1320	689	1550	45,4	2.77	0,36	0.80	✓
RS 350 - 077 - A	RS 350 - 077 - B	77	3.03	190	7.48	113	4.45											589	1323	691	1554	48,4	2.95	0,38	0.83	✓
RS 350 - 097 - A	RS 350 - 097 - B	97	3.82	230	9.06	133	5.24											593	1332	697	1567	60,3	3.68	0,44	0.96	✓
RS 350 - 122 - A	RS 350 - 122 - B	122	4.80	280	11.02	158	6.22											602	1354	712	1600	73,9	4.51	0,51	1.13	✓

◆ Disposable

WARNING REMOVE SKUDO

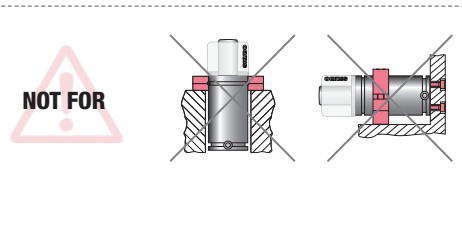
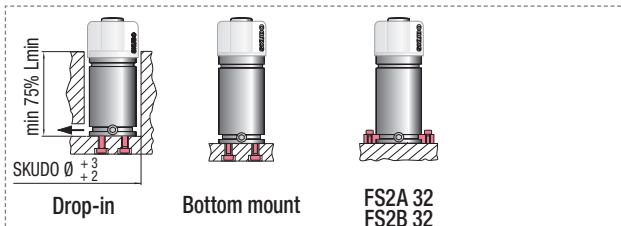

HOW TO ORDER
p. 73

INSTALLATION GUIDELINE
p. 205



ACTIVE SAFETY



OSAS



USAS



OPAS



SKUDO

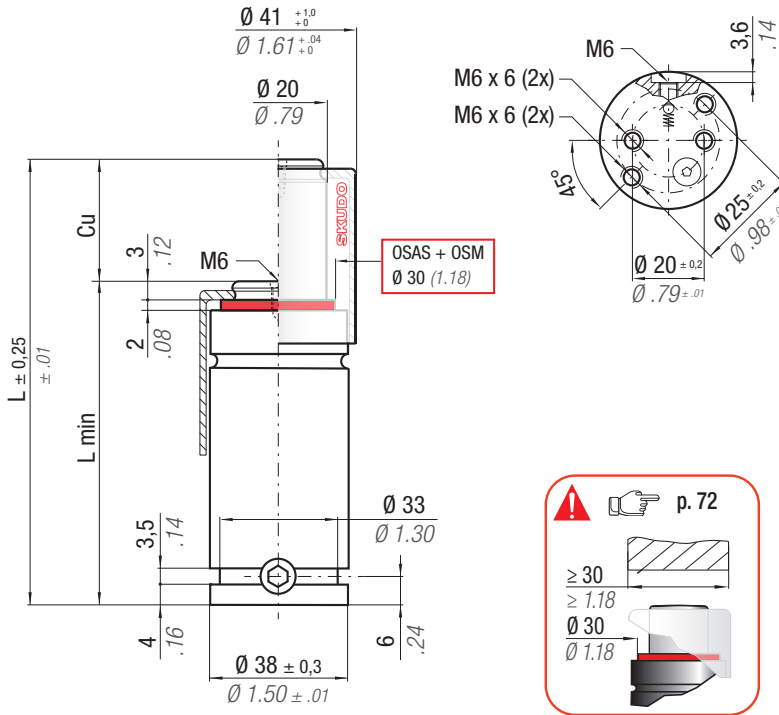

OSAS + OSM = OVER STROKE ACTIVE SAFETY + OVER STROKE SAFETY MARKER

Il nuovo codice sarà fornito solo ad esaurimento del vecchio
 The new code will be supplied only when the old will be out of stock
 Der neue Kode wird nur angegeben, wenn der alte nicht mehr lieferbar ist
 Le nouveau code sera fourni uniquement lorsque le vieux stock sera écoulé
 El nuevo código será suministrado sólo cuando se agoten las existencias del antiguo
 O novo código irá ser fornecido apenas quando o antigo esgotar stock

easU MANIFOLD p. 247

p. 262

* F_{1i} = Isothermal end force at 100% Cu p. 16

** F_{1p} = Polytrophic end force at 100% Cu p. 16

RS

	0 - 80 °C 32 - 176 °F	ΔP ± 0,33 %/°C	P max 150 bar 2175 psi	P min 20 bar 290 psi	S 3,14 cm ² 0.487 in ²	SPM ~ 20 - 100 (at 20°C)	Max Speed 1,8 m/s 70.8 in/s	Maintenance kit 39BMRV00500C
--	--------------------------	---------------------------	-------------------------------------	-----------------------------------	-----------------------------------------------------------	---------------------------------------	------------------------------------------	----------------------------------------

CODE PHASING OUT from 04/2021	NEW	Cu		L		L min		F ₀ Initial force		F _{1i} * End force *		F _{1p} ** End force **		V ₀		PED 2014/68/EU		
		mm	inch	mm	inch	mm	inch	daN	lb	daN	lb	daN	lb	cm ³	in ³	~Kg	~lb	✓
RS 500 - 007 - A	♦ RS 500 - 007 - B	7	0.28	50	1.97	43	1.69	470 1057 ± 5%	150 bar 2175psi	611	1375	697	1567	11,2	0.68	0,24	0.53	✓
RS 500 - 010 - A	♦ RS 500 - 010 - B	10	0.39	56	2.20	46	1.81			642	1443	743	1671	13,7	0.84	0,25	0.55	✓
RS 500 - 013 - A	RS 500 - 013 - B	13	0.51	62	2.44	49	1.93			664	1493	778	1749	16,3	0.99	0,26	0.57	✓
RS 500 - 016 - A	RS 500 - 016 - B	16	0.63	68	2.68	52	2.05			682	1532	805	1810	18,9	1.15	0,28	0.62	✓
RS 500 - 022 - A	RS 500 - 022 - B	22	0.87	80	3.15	58	2.28			707	1588	845	1899	24,0	1.46	0,31	0.68	✓
RS 500 - 029 - A	RS 500 - 029 - B	29	1.14	94	3.70	65	2.56			726	1632	876	1968	29,9	1.82	0,34	0.75	✓
RS 500 - 035 - A	RS 500 - 035 - B	35	1.38	106	4.17	71	2.80			738	1659	895	2011	35,0	2.14	0,37	0.82	✓
RS 500 - 047 - A	RS 500 - 047 - B	47	1.85	130	5.12	83	3.27			754	1695	921	2070	45,2	2.76	0,42	0.93	✓
RS 500 - 060 - A	RS 500 - 060 - B	60	2.36	156	6.14	96	3.78			765	1721	939	2111	56,3	3.44	0,48	1.06	✓
RS 500 - 072 - A	RS 500 - 072 - B	72	2.83	180	7.09	108	4.25			773	1737	951	2138	66,5	4.06	0,54	1.19	✓
RS 500 - 077 - A	RS 500 - 077 - B	77	3.03	190	7.48	113	4.45	775	1742	955	2147	70,8	4.32	0,56	1.23	✓		
RS 500 - 097 - A	RS 500 - 097 - B	97	3.82	230	9.06	133	5.24	783	1759	967	2174	87,8	5.36	0,66	1.46	✓		
RS 500 - 122 - A	RS 500 - 122 - B	122	4.80	280	11.02	158	6.22	789	1773	977	2197	109,1	6.66	0,77	1.70	✓		

♦ Disposable

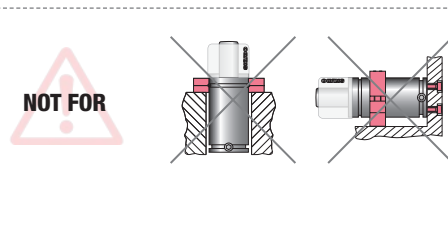
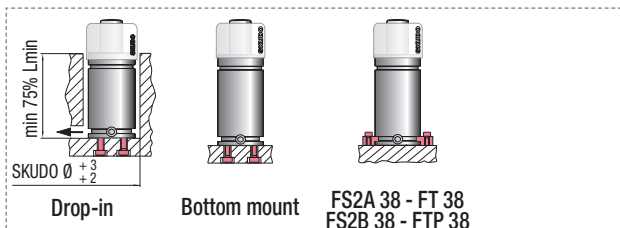
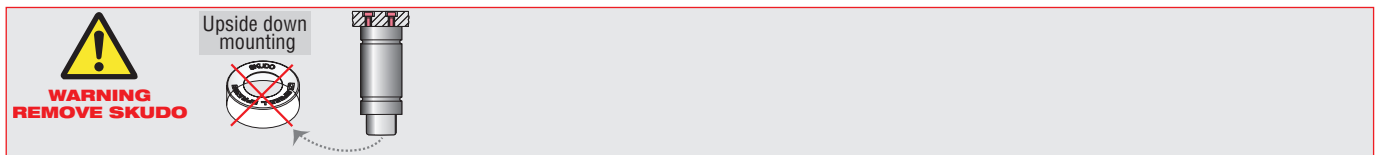

HOW TO ORDER

p. 73

INSTALLATION GUIDELINE

p. 205



OSAS + OSM = **OVER STROKE ACTIVE SAFETY** + **OVER STROKE MARKER**

ACTIVE SAFETY



OSAS



USAS



OPAS



SKUDO

Il nuovo codice sarà fornito solo ad esaurimento del vecchio

The new code will be supplied only when the old will be out of stock

Der neue Kode wird nur angegeben, wenn der alte nicht mehr lieferbar ist

Le nouveau code sera fourni uniquement lorsque le vieux stock sera écolé

El nuevo código será suministrado sólo cuando se agoten las existencias del antiguo

O novo código irá ser fornecido apenas quando o antigo esgotar stock

easyl MANIFOLD p. 247

p. 262

* F_{1i} =

Isothermal end force at 100% Cu



p. 16

** F_{1p} =

Polytropic end force at 100% Cu

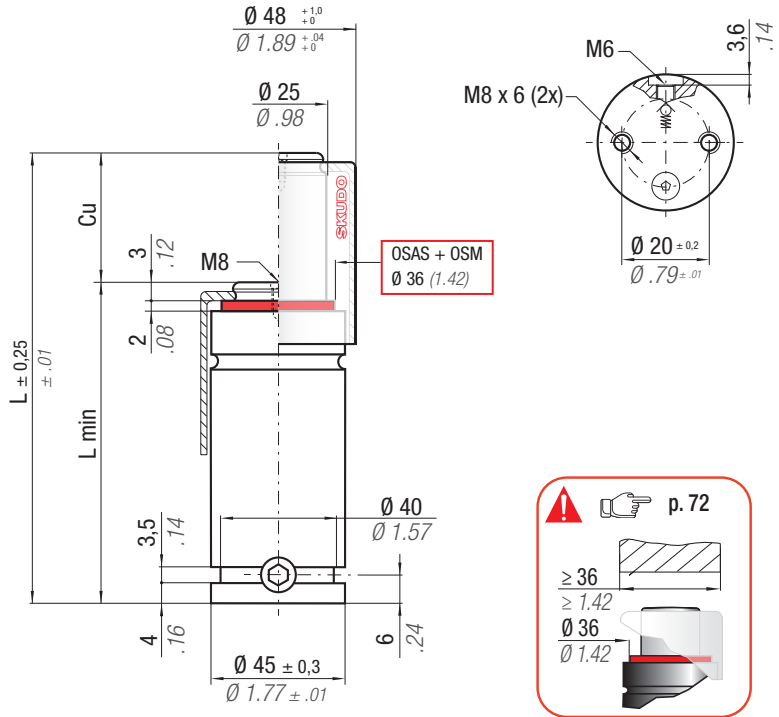

N₂	0 - 80 °C 32 - 176 °F	ΔP ± 0,33 %/°C	P max 150 bar 2175 psi	P min 20 bar 290 psi	S 4,91 cm ² 0,761 in ²	SPM ~ 20 - 100 (at 20°C)	Max Speed 1,8 m/s 70,8 in/s	Maintenance kit 39BMRV00750C
----------------------	--------------------------	---------------------------	-------------------------------------	-----------------------------------	-----------------------------------------------------------	---------------------------------------	------------------------------------------	----------------------------------------

CODE PHASING OUT from 04/2021	NEW	Cu		L		L min		F ₀		F _{1i} *		F _{1p} **		V ₀		~Kg	~lb	PED 2014/68/EU
		mm	inch	mm	inch	mm	inch	daN	lb	daN	lb	daN	lb	cm ³	in ³			
RS 750 - 007 - A	◆ RS 750 - 007 - B	7	0.28	52	2.05	45	1.77	740 ± 5% 150 bar 2175psi + 20 °C +68 °F	1664	972	2185	1114	2504	16,5	1.01	0,36	0,79	✓
RS 750 - 010 - A	◆ RS 750 - 010 - B	10	0.39	58	2.28	48	1.89			1024	2301	1193	2683	20,3	1.24	0,38	0,84	✓
RS 750 - 013 - A	RS 750 - 013 - B	13	0.51	64	2.52	51	2.01			1062	2388	1253	2818	24,1	1.47	0,39	0,86	✓
RS 750 - 016 - A	RS 750 - 016 - B	16	0.63	70	2.76	54	2.13			1092	2454	1300	2923	27,9	1.70	0,41	0,90	✓
RS 750 - 022 - A	RS 750 - 022 - B	22	0.87	82	3.23	60	2.36			1135	2551	1369	3077	35,4	2.16	0,45	0,99	✓
RS 750 - 029 - A	RS 750 - 029 - B	29	1.14	96	3.78	67	2.64			1168	2627	1423	3198	44,3	2.70	0,50	1.10	✓
RS 750 - 035 - A	RS 750 - 035 - B	35	1.38	108	4.25	73	2.87			1189	2673	1456	3273	51,8	3.16	0,54	1.19	✓
RS 750 - 047 - A	RS 750 - 047 - B	47	1.85	132	5.20	85	3.35			1217	2736	1502	3377	67,0	4.09	0,61	1.34	✓
RS 750 - 060 - A	RS 750 - 060 - B	60	2.36	158	6.22	98	3.86			1237	2781	1535	3450	83,4	5.09	0,70	1.54	✓
RS 750 - 072 - A	RS 750 - 072 - B	72	2.83	182	7.17	110	4.33			1250	2809	1556	3497	98,5	6.01	0,77	1.70	✓
RS 750 - 077 - A	RS 750 - 077 - B	77	3.03	192	7.56	115	4.53			1254	2819	1563	3513	104,8	6.40	0,81	1.79	✓
RS 750 - 097 - A	RS 750 - 097 - B	97	3.82	232	9.13	135	5.31			1267	2848	1584	3561	130,0	7.93	0,93	2.05	✓
RS 750 - 122 - A	RS 750 - 122 - B	122	4.80	282	11.10	160	6.30			1278	2872	1602	3602	161,5	9.86	1,10	2.43	✓

◆ Disposable

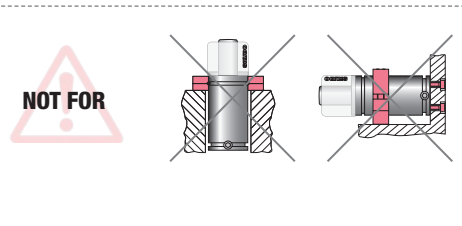
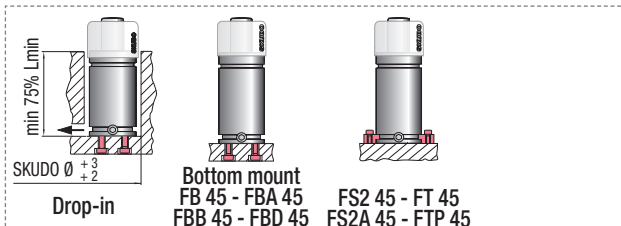
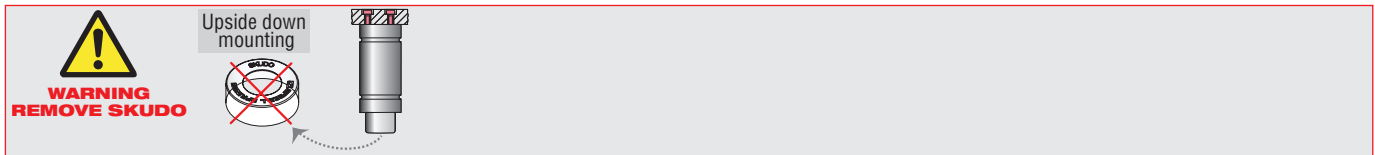

HOW TO ORDER
p. 73

INSTALLATION GUIDELINE
p. 205

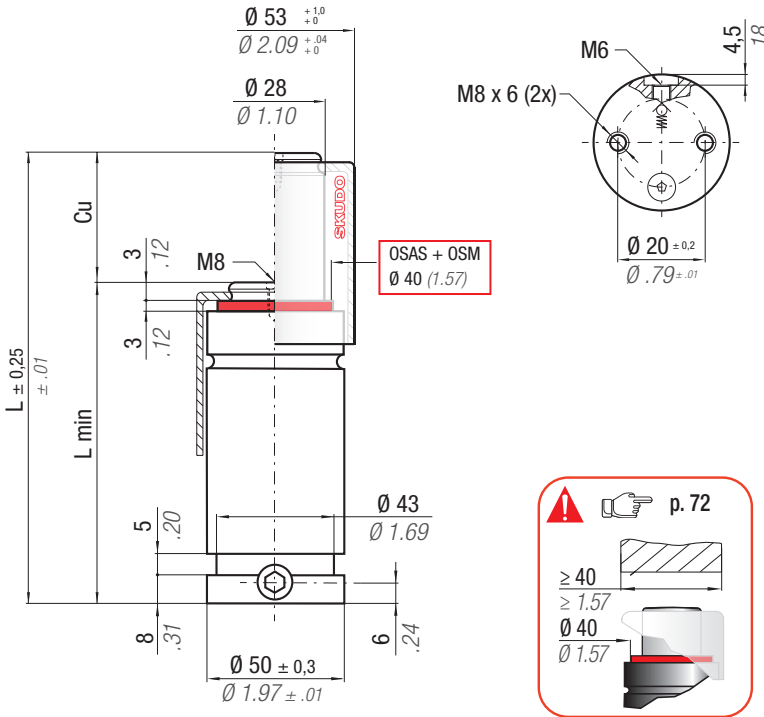

OSAS + OSM = OVER STROKE ACTIVE SAFETY + OVER STROKE MARKER

Il nuovo codice sarà fornito solo ad esaurimento del vecchio
 The new code will be supplied only when the old will be out of stock
 Der neue Kode wird nur angegeben, wenn der alte nicht mehr lieferbar ist
 Le nouveau code sera fourni uniquement lorsque le vieux stock sera écoulé
 El nuevo código será suministrado sólo cuando se agoten las existencias del antiguo
 O novo código irá ser fornecido apenas quando o antigo esgotar stock

easU MANIFOLD p. 247 p. 262

* F_{1i} = Isothermal end force at 100% Cu p. 16
 ** F_{1p} = Polytrophic end force at 100% Cu

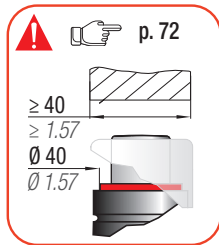

ACTIVE SAFETY



OSAS



USAS



OPAS



SKUDO

RS

		0 - 80 °C 32 - 176 °F	ΔP ± 0,33 %/°C	P max 150 bar 2175 psi	P min 20 bar 290 psi	S 6,15 cm ² 0.953 in ²	SPM ~ 20 - 100 (at 20°C)	Max Speed 1,8 m/s 70.8 in/s	Maintenance kit 39BMRV01000C	
CODE PHASING OUT from 04/2021	NEW	Cu	L	L min	F ₀ Initial force	F _{1i} * End force *	F _{1p} ** End force **	V ₀		
RS 1000 - 010 - A	◆ RS 1000 - 010 - B	10 0.39	64 2.52	54 2.13	920 2068 ± 5%	1236 2779	1424 3200	28,4 1.73	0,51 1.12	✓
RS 1000 - 013 - A	◆ RS 1000 - 013 - B	13 0.51	70 2.76	57 2.24		1285 2889	1499 3370	33,0 2.01	0,54 1.19	✓
RS 1000 - 016 - A	RS 1000 - 016 - B	16 0.63	76 2.99	60 2.36		1325 2978	1560 3508	37,7 2.30	0,56 1.23	✓
RS 1000 - 022 - A	RS 1000 - 022 - B	22 0.87	88 3.46	66 2.60		1384 3110	1653 3717	47,0 2.87	0,61 1.34	✓
RS 1000 - 029 - A	RS 1000 - 029 - B	29 1.14	102 4.02	73 2.87		1432 3219	1730 3889	58,0 3.54	0,67 1.48	✓
RS 1000 - 035 - A	RS 1000 - 035 - B	35 1.38	114 4.49	79 3.11		1462 3287	1779 3999	67,3 4.11	0,71 1.57	✓
RS 1000 - 047 - A	RS 1000 - 047 - B	47 1.85	138 5.43	91 3.58		1505 3383	1848 4156	86,0 5.25	0,81 1.79	✓
RS 1000 - 060 - A	RS 1000 - 060 - B	60 2.36	164 6.46	104 4.09		1536 3452	1899 4269	106,3 6.49	0,91 2.01	✓
RS 1000 - 072 - A	RS 1000 - 072 - B	72 2.83	188 7.40	116 4.57		1556 3498	1932 4343	125,0 7.63	1,05 2.31	✓
RS 1000 - 077 - A	RS 1000 - 077 - B	77 3.03	198 7.80	121 4.76		1563 3513	1943 4368	132,8 8.10	1,09 2.40	✓
RS 1000 - 097 - A	RS 1000 - 097 - B	97 3.82	238 9.37	141 5.55	1584 3560	1978 4447	163,9 10.00	1,21 2.67	✓	
RS 1000 - 122 - A	RS 1000 - 122 - B	122 4.80	288 11.34	166 6.54	1601 3600	2008 4513	202,9 12.38	1,41 3.11	✓	

◆ Disposable

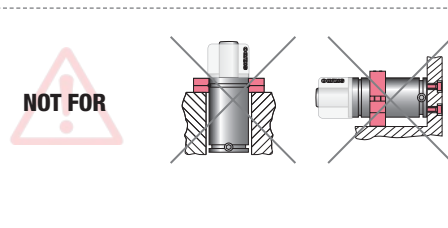
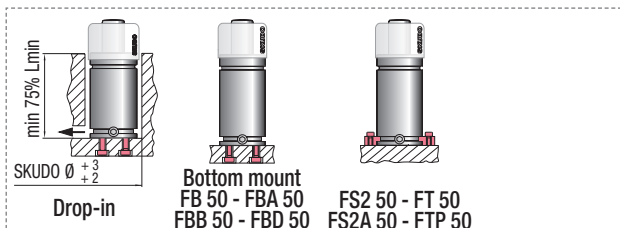
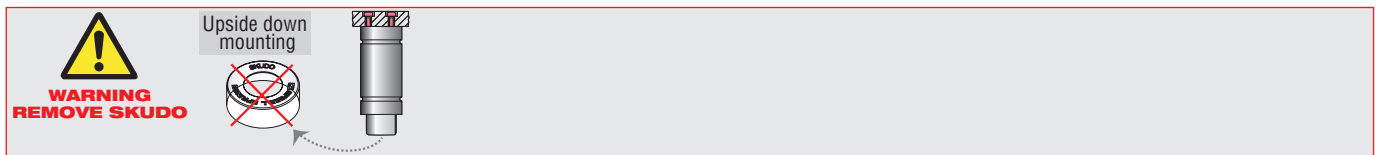

HOW TO ORDER

p. 73

INSTALLATION GUIDELINE

p. 205



OSAS + OSM = **OVER STROKE ACTIVE SAFETY** + **OVER STROKE MARKER**

ACTIVE SAFETY



OSAS



USAS



OPAS



SKUDO

Il nuovo codice sarà fornito solo ad esaurimento del vecchio

The new code will be supplied only when the old will be out of stock

Der neue Kode wird nur angegeben, wenn der alte nicht mehr lieferbar ist

Le nouveau code sera fourni uniquement lorsque le vieux stock sera écolé

El nuevo código será suministrado sólo cuando se agoten las existencias del antiguo

O novo código irá ser fornecido apenas quando o antigo esgotar stock

easyl MANIFOLD p. 247

p. 262

* F_{1i} = Isothermal end force at 100% Cu p. 16

** F_{1p} = Polytrophic end force at 100% Cu

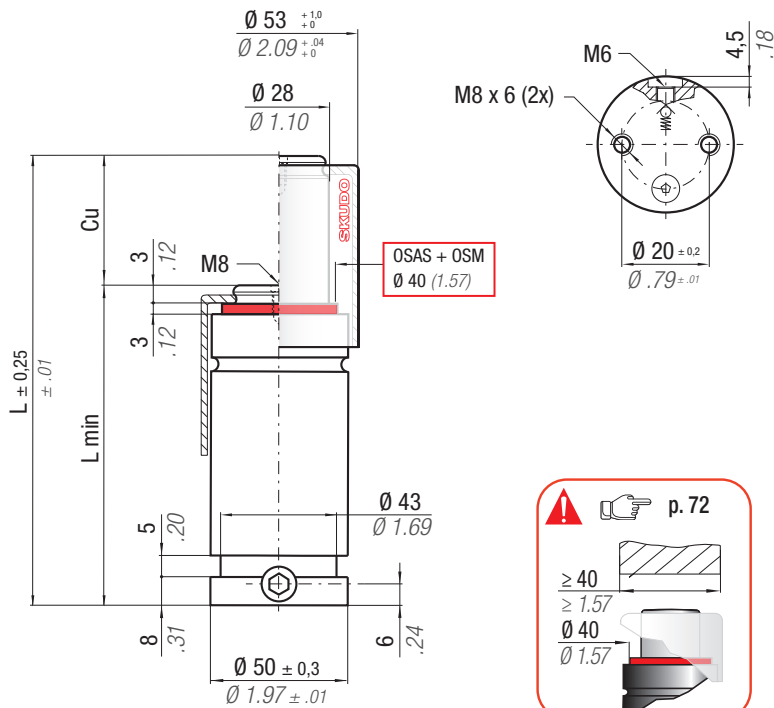

N ₂		0 - 80 °C 32 - 176 °F	ΔP ± 0,33 %/°C	P max 170 bar 2465 psi	P min 20 bar 290 psi	S 6,15 cm ² 0,953 in ²	SPM ~ 20 - 100 (at 20°C)	Max Speed 1,8 m/s 70,8 in/s	Maintenance kit 39BMRV01000C	
CODE	NEW	Cu	L	L min	F ₀	F _{1i} *	F _{1p} **	V ₀	PED	
PHASING OUT from 04/2021		mm inch	mm inch	mm inch	Initial force daN lb	End force * daN lb	End force ** daN lb	cm ³ in ³	~Kg ~lb	2014/68/EU
RS 1200 - 010 - A	◆ RS 1200 - 010 - B	10 0.39	64 2.52	54 2.13	1047 2354 ± 5% 170 bar 2465 psi + 20 °C +68 °F	1418 3187	1605 3608	28,4 1.73	0,51 1.12	✓
RS 1200 - 013 - A	◆ RS 1200 - 013 - B	13 0.51	70 2.76	57 2.24		1476 3318	1690 3799	33,0 2.01	0,54 1.19	✓
RS 1200 - 016 - A	RS 1200 - 016 - B	16 0.63	76 2.99	60 2.36		1523 3424	1759 3954	37,7 2.30	0,56 1.23	✓
RS 1200 - 022 - A	RS 1200 - 022 - B	22 0.87	88 3.46	66 2.60		1594 3583	1864 4190	47,0 2.87	0,61 1.34	✓
RS 1200 - 029 - A	RS 1200 - 029 - B	29 1.14	102 4.02	73 2.87		1652 3713	1950 4385	58,0 3.54	0,67 1.48	✓
RS 1200 - 035 - A	RS 1200 - 035 - B	35 1.38	114 4.49	79 3.11		1688 3795	2006 4509	67,3 4.11	0,71 1.57	✓
RS 1200 - 047 - A	RS 1200 - 047 - B	47 1.85	138 5.43	91 3.58		1740 3911	2084 4685	86,0 5.25	0,81 1.79	✓
RS 1200 - 060 - A	RS 1200 - 060 - B	60 2.36	164 6.46	104 4.09		1776 3994	2141 4812	106,3 6.49	0,91 2.01	✓
RS 1200 - 072 - A	RS 1200 - 072 - B	72 2.83	188 7.40	116 4.57		1801 4048	2178 4896	125,0 7.63	1,05 2.31	✓
RS 1200 - 077 - A	RS 1200 - 077 - B	77 3.03	198 7.80	121 4.76		1809 4067	2191 4925	132,8 8.10	1,09 2.40	✓
RS 1200 - 097 - A	RS 1200 - 097 - B	97 3.82	238 9.37	141 5.55	1834 4124	2230 5014	163,9 10.00	1,21 2.67	✓	
RS 1200 - 122 - A	RS 1200 - 122 - B	122 4.80	288 11.34	166 6.54	1856 4172	2263 5088	202,9 12.38	1,41 3.11	✓	

◆ Disposable

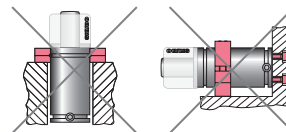
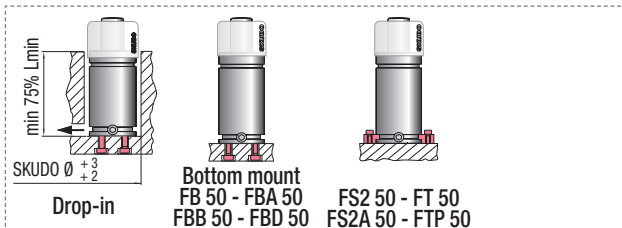
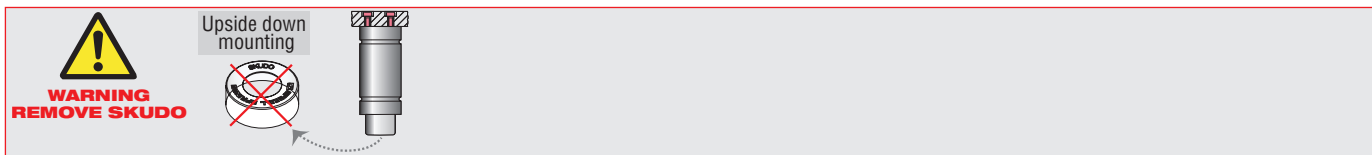

HOW TO ORDER

p. 73

INSTALLATION GUIDELINE

p. 205

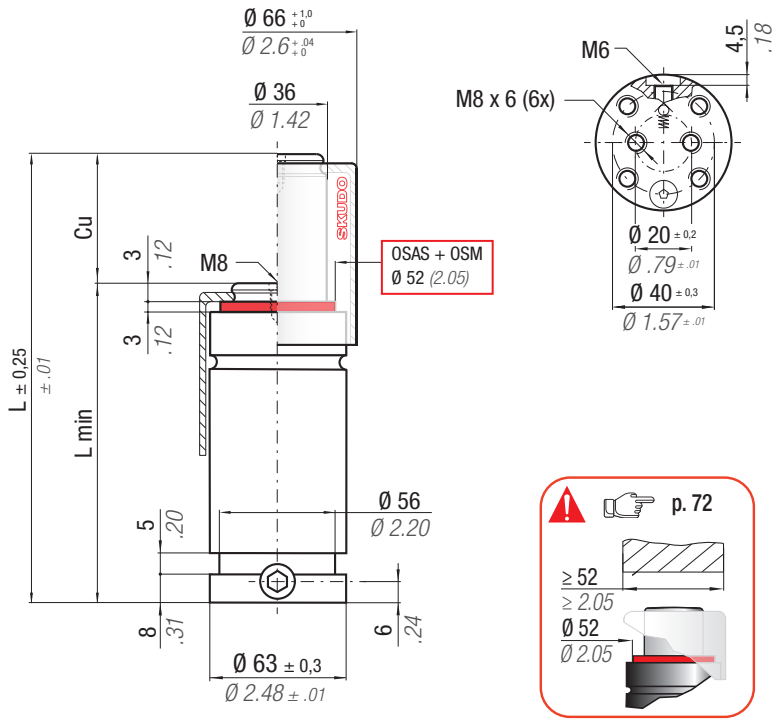

OSAS + OSM = OVER STROKE ACTIVE SAFETY + OVER STROKE MARKER



Il nuovo codice sarà fornito solo ad esaurimento del vecchio
 The new code will be supplied only when the old will be out of stock
 Der neue Kode wird nur angegeben, wenn der alte nicht mehr lieferbar ist
 Le nouveau code sera fourni uniquement lorsque le vieux stock sera écoulé
 El nuevo código será suministrado sólo cuando se agoten las existencias del antiguo
 O novo código irá ser fornecido apenas quando o antigo esgotar stock

ACTIVE SAFETY



OSAS



USAS



OPAS



SKUDO

eas MANIFOLD p. 247

p. 262

* F_{1i} = Isothermal end force at 100% Cu p. 16

** F_{1p} = Polytrophic end force at 100% Cu

RS

	0 - 80 °C 32 - 176 °F	ΔP $\pm 0,33\% / ^\circ C$	P max 150 bar 2175 psi	P min 20 bar 290 psi	S 10,18 cm ² 1.578 in ²	SPM ~ 20 - 100 (at 20°C)	Max Speed 1,8 m/s 70.8 in/s	Maintenance kit 39BMRV01500C
--	--------------------------	---------------------------------------	-------------------------------------	-----------------------------------	------------------------------------------------------------	---------------------------------------	------------------------------------------	----------------------------------------

CODE PHASING OUT from 04/2021	NEW	Cu		L		L min		F0 Initial force		F1i * End force *		F1p ** End force **		V0		PED 2014/68/EU		
		mm	inch	mm	inch	mm	inch	daN	lb	daN	lb	daN	lb	cm ³	in ³	~Kg	~lb	✓
RS 1500 - 010 - B	◆ RS 1500 - 010 - C	10	0.39	70	2.76	60	2.36	1530 3440 ± 5%	1981	4453	2258	5076	52	3.17	0,92	2,03	✓	
RS 1500 - 013 - B	◆ RS 1500 - 013 - C	13	0.51	76	2.99	63	2.48			2057	4625	2374	5337	60	3.66	0,96	2,12	✓
RS 1500 - 016 - B	RS 1500 - 016 - C	16	0.63	82	3.23	66	2.60			2119	4764	2470	5552	68	4.15	0,99	2,18	✓
RS 1500 - 022 - B	RS 1500 - 022 - C	22	0.87	94	3.70	72	2.83			2214	4978	2618	5885	83	5.06	1,06	2,34	✓
RS 1500 - 029 - B	RS 1500 - 029 - C	29	1.14	108	4.25	79	3.11			2294	5156	2743	6166	102	6.22	1,14	2,51	✓
RS 1500 - 035 - B	RS 1500 - 035 - C	35	1.38	120	4.72	85	3.35			2344	5270	2824	6348	118	7.20	1,21	2,67	✓
RS 1500 - 047 - B	RS 1500 - 047 - C	47	1.85	144	5.67	97	3.82			2417	5433	2940	6610	149	9.09	1,35	2,98	✓
RS 1500 - 060 - B	RS 1500 - 060 - C	60	2.36	170	6.69	110	4.33			2470	5552	3026	6803	184	11.23	1,51	3,33	✓
RS 1500 - 072 - B	RS 1500 - 072 - C	72	2.83	194	7.64	122	4.80			2505	5631	3083	6931	215	13.12	1,65	3,64	✓
RS 1500 - 077 - B	RS 1500 - 077 - C	77	3.03	204	8.03	127	5.00			2517	5657	3103	6975	229	13.97	1,71	3,77	✓
RS 1500 - 097 - B	RS 1500 - 097 - C	97	3.82	244	9.61	147	5.79	2554	5741	3164	7112	281	17.15	1,94	4,28	✓		
RS 1500 - 122 - B	RS 1500 - 122 - C	122	4.80	294	11.57	172	6.77	2585	5811	3215	7228	347	21.18	2,23	4,92	✓		

◆ Disposable

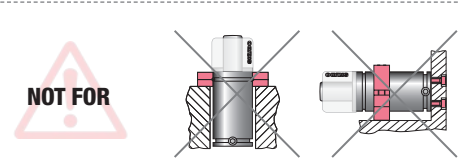
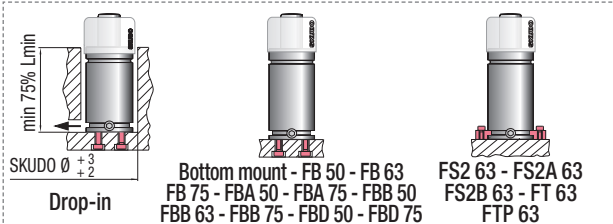
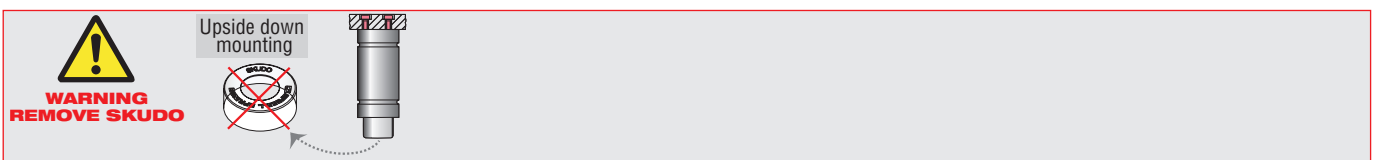

HOW TO ORDER p. 73
INSTALLATION GUIDELINE p. 205



OSAS + OSM = **OVER STROKE ACTIVE SAFETY** + **OVER STROKE MARKER**

ACTIVE SAFETY



OSAS



USAS



OPAS



SKUDO

Il nuovo codice sarà fornito solo ad esaurimento del vecchio

The new code will be supplied only when the old will be out of stock

Der neue Kode wird nur angegeben, wenn der alte nicht mehr lieferbar ist

Le nouveau code sera fourni uniquement lorsque le vieux stock sera écolé

El nuevo código será suministrado sólo cuando se agoten las existencias del antiguo

O novo código irá ser fornecido apenas quando o antigo esgotar stock

easyl MANIFOLD p. 247

p. 262

* F_{1i} =

Isothermal end force at 100% Cu



p. 16

** F_{1p} =

Polytropic end force at 100% Cu

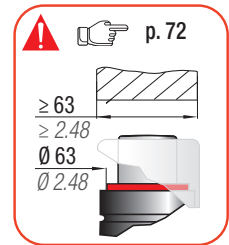
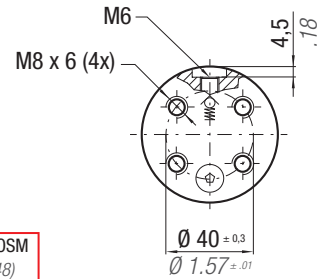
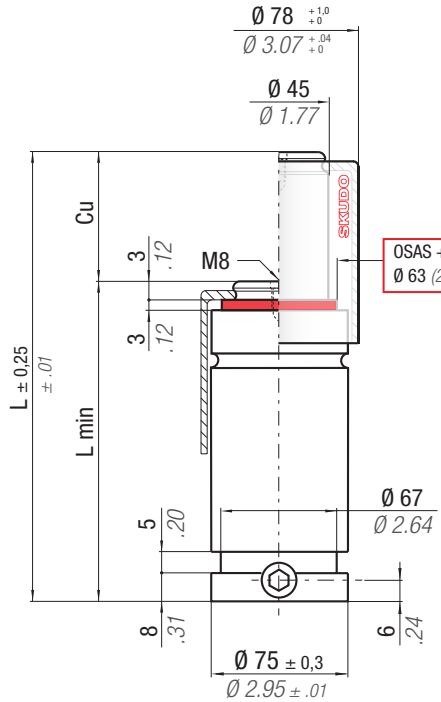

N ₂		0 - 80 °C 32 - 176 °F	ΔP ± 0,33 %/°C	P max 150 bar 2175 psi	P min 20 bar 290 psi	S 15,90 cm ² 2,465 in ²	SPM ~ 20 - 100 (at 20°C)	Max Speed 1,8 m/s 70,8 in/s	Maintenance kit 39BMRV02400D	
CODE	NEW	Cu	L	L min	F ₀	F _{1i} *	F _{1p} **	V ₀	PED	
PHASING OUT from 04/2021		mm inch	mm inch	mm inch	Initial force daN lb	End force * daN lb	End force ** daN lb	cm ³ in ³	~Kg ~lb	2014/68/EU
RS 2400 - 013 - A	◆ RS 2400 - 013 - B	13 0.51	77 3.03	64 2.52	2385 5362 ± 5% 150 bar 2175 psi + 20 °C +68 °F	3232 7267	3737 8402	92 5.61	1,36 3,00	✓
RS 2400 - 016 - A	◆ RS 2400 - 016 - B	16 0.63	83 3.27	67 2.64		3334 7495	3894 8755	104 6.35	1,40 3,09	✓
RS 2400 - 022 - A	RS 2400 - 022 - B	22 0.87	95 3.74	73 2.87		3491 7847	4139 9305	128 7.81	1,50 3,31	✓
RS 2400 - 029 - A	RS 2400 - 029 - B	29 1.14	109 4.29	80 3.15		3622 8142	4347 9772	156 9.52	1,61 3,55	✓
RS 2400 - 035 - A	RS 2400 - 035 - B	35 1.38	121 4.76	86 3.39		3706 8332	4482 10076	180 10.98	1,70 3,75	✓
RS 2400 - 047 - A	RS 2400 - 047 - B	47 1.85	145 5.71	98 3.86		3828 8606	4678 10517	228 13.91	1,89 4,17	✓
RS 2400 - 060 - A	RS 2400 - 060 - B	60 2.36	171 6.73	111 4.37		3917 8806	4823 10843	280 17.09	2,09 4,61	✓
RS 2400 - 072 - A	RS 2400 - 072 - B	72 2.83	195 7.68	123 4.84		3976 8939	4920 11061	328 20.02	2,28 5,03	✓
RS 2400 - 077 - A	RS 2400 - 077 - B	77 3.03	205 8.07	128 5.04		3996 8984	4953 11136	348 21.24	2,36 5,20	✓
RS 2400 - 097 - A	RS 2400 - 097 - B	97 3.82	245 9.65	148 5.83		4059 9126	5057 11369	428 26.12	2,67 5,89	✓
RS 2400 - 122 - A	RS 2400 - 122 - B	122 4.80	295 11.61	173 6.81	4113 9246	5146 11568	528 32.22	3,07 6,77	✓	

◆ Disposable

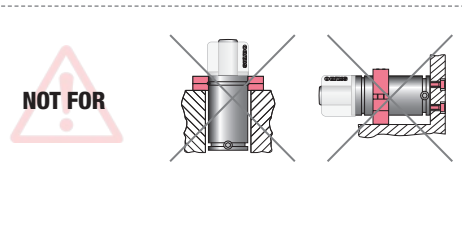
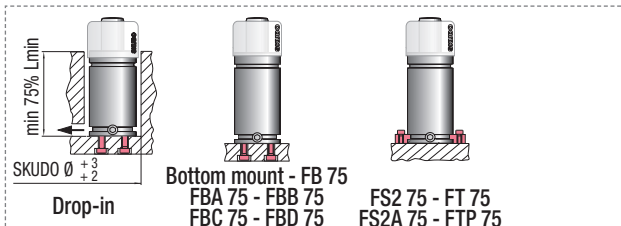
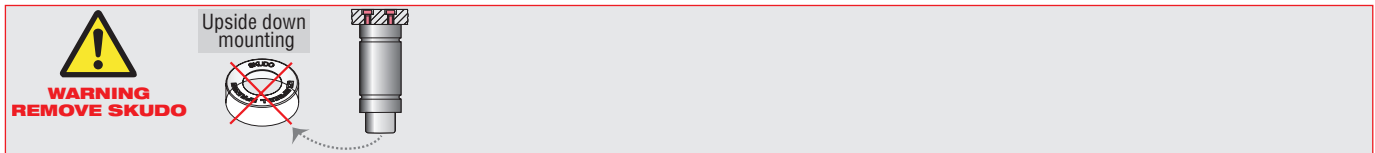

HOW TO ORDER
p. 73

INSTALLATION GUIDELINE
p. 205

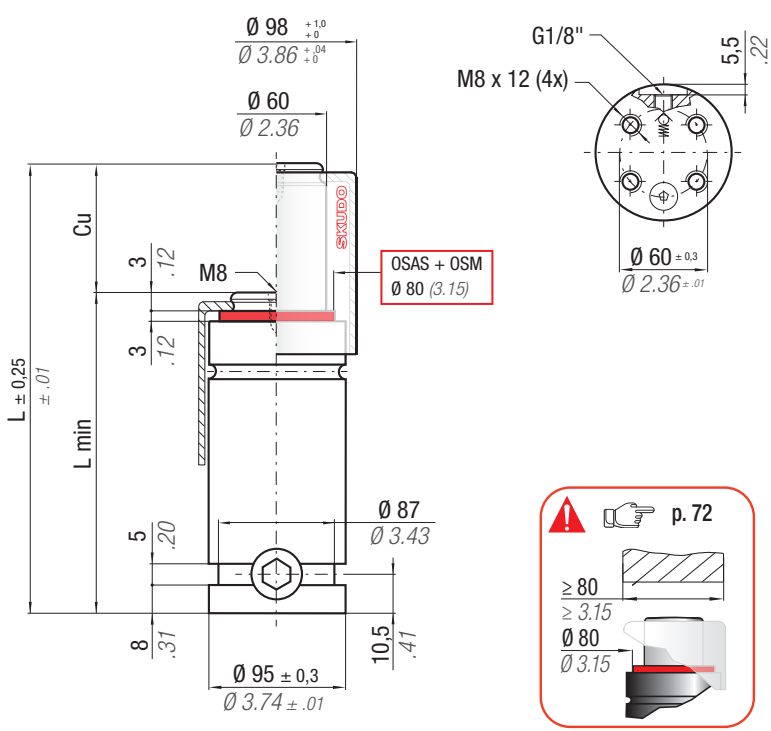

OSAS + OSM = OVER STROKE ACTIVE SAFETY + OVER STROKE MARKER



Il nuovo codice sarà fornito solo ad esaurimento del vecchio
 The new code will be supplied only when the old will be out of stock
 Der neue Kode wird nur angegeben, wenn der alte nicht mehr lieferbar ist
 Le nouveau code sera fourni uniquement lorsque le vieux stock sera écoulé
 El nuevo código será suministrado sólo cuando se agoten las existencias del antiguo
 O novo código irá ser fornecido apenas quando o antigo esgotar stock

ACTIVE SAFETY



easU MANIFOLD p. 247 p. 262

* F_{1i} = Isothermal end force at 100% Cu p. 16
 ** F_{1p} = Polytrophic end force at 100% Cu



RS

	0 - 80 °C 32 - 176 °F	ΔP $\pm 0,33\% / ^\circ C$	P max 150 bar 2175 psi	P min 20 bar 290 psi	S 28,27 cm ² 4.382 in ²	SPM ~ 20 - 100 (at 20°C)	Max Speed 1,8 m/s 70.8 in/s	Maintenance kit 39BMRV04200C
--	--------------------------	---------------------------------------	-------------------------------------	-----------------------------------	------------------------------------------------------------	---------------------------------------	------------------------------------------	----------------------------------------

CODE PHASING OUT from 04/2021	NEW	Cu		L		L min		F0 Initial force		F1i * End force *		F1p ** End force **		V0		PED 2014/68/EU		
		mm	inch	mm	inch	mm	inch	daN	lb	daN	lb	daN	lb	cm ³	in ³	~Kg	~lb	✓
RS 4200 - 013 - A	◆ RS 4200 - 013 - B	13	0.51	90	3.54	77	3.03	4240 9532 ± 5%	150 bar 2175 psi	5651	12703	6498	14607	172	10.50	2,76	6.08	✓
RS 4200 - 016 - A	◆ RS 4200 - 016 - B	16	0.63	96	3.78	80	3.15			5842	13133	6791	15267	192	11.72	2,83	6.24	✓
RS 4200 - 022 - A	RS 4200 - 022 - B	22	0.87	108	4.25	86	3.39			6147	13819	7266	16334	232	14.16	2,98	6.57	✓
RS 4200 - 029 - A	RS 4200 - 029 - B	29	1.14	122	4.80	93	3.66			6413	14417	7687	17280	279	17.03	3,16	6.97	✓
RS 4200 - 035 - A	RS 4200 - 035 - B	35	1.38	134	5.28	99	3.90			6590	14815	7969	17915	320	19.53	3,30	7.28	✓
RS 4200 - 047 - A	RS 4200 - 047 - B	47	1.85	158	6.22	111	4.37			6852	15403	8392	18866	401	24.47	3,60	7.94	✓
RS 4200 - 060 - A	RS 4200 - 060 - B	60	2.36	184	7.24	124	4.88			7049	15848	8715	19593	488	29.78	3,93	8.66	✓
RS 4200 - 072 - A	RS 4200 - 072 - B	72	2.83	208	8.19	136	5.35			7184	16149	8936	20089	569	34.72	4,20	9.26	✓
RS 4200 - 077 - A	RS 4200 - 077 - B	77	3.03	218	8.58	141	5.55			7230	16254	9013	20262	603	36.80	4,35	9.59	✓
RS 4200 - 097 - A	RS 4200 - 097 - B	97	3.82	258	10.16	161	6.34			7377	16583	9256	20809	737	44.97	4,85	10.69	✓
RS 4200 - 122 - A	RS 4200 - 122 - B	122	4.80	308	12.13	186	7.32	7503	16867	9467	21283	906	55.29	5,47	12.06	✓		

◆ Disposable

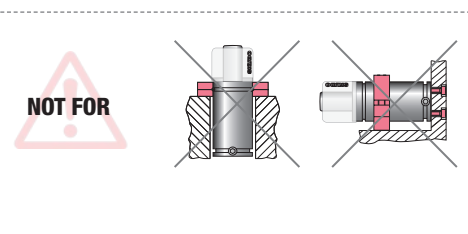
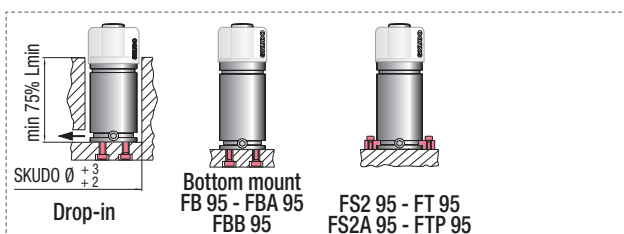
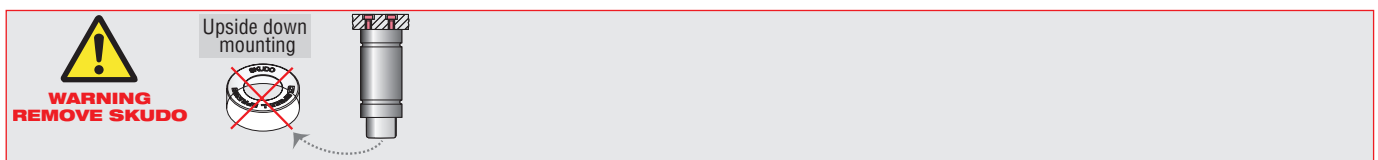

HOW TO ORDER p. 73
INSTALLATION GUIDELINE p. 205



OSAS + OSM = **OVER STROKE ACTIVE SAFETY** + **OVER STROKE MARKER**

ACTIVE SAFETY

Il nuovo codice sarà fornito solo ad esaurimento del vecchio

The new code will be supplied only when the old will be out of stock

Der neue Kode wird nur angegeben, wenn der alte nicht mehr lieferbar ist

Le nouveau code sera fourni uniquement lorsque le vieux stock sera écolé

El nuevo código será suministrado sólo cuando se agoten las existencias del antiguo

O novo código irá ser fornecido apenas quando o antigo esgotar stock



OSAS



USAS



OPAS



SKUDO

easyl MANIFOLD p. 247

easyl MANIFOLD p. 262

* F_{1i} =

Isothermal end force at 100% Cu



p. 16

** F_{1p} =

Polytropic end force at 100% Cu

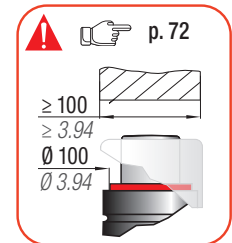
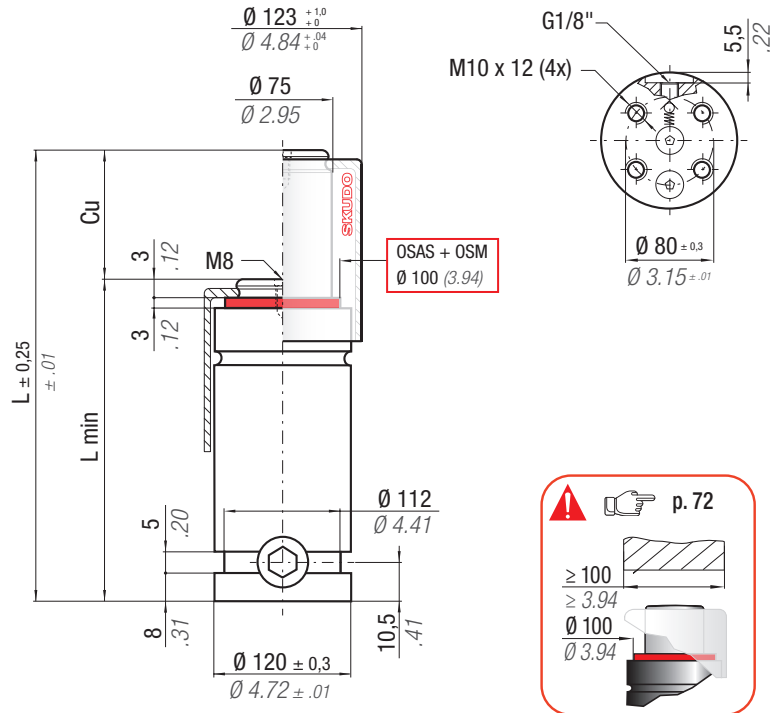

	0 - 80 °C 32 - 176 °F	ΔP ± 0,33 %/°C	P max 150 bar 2175 psi	P min 20 bar 290 psi	S 44,18 cm ² 6.848 in ²	SPM ~ 20 - 100 (at 20°C)	Max Speed 1,8 m/s 70.8 in/s	Maintenance kit 39BMRV06600C
--	--------------------------	---------------------------	------------------------------	----------------------------	-----------------------------------------------------	--------------------------------	-----------------------------------	---------------------------------

CODE PHASING OUT from 04/2021	NEW	Cu		L		L min		F ₀ Initial force		F _{1i} * End force *		F _{1p} ** End force **		V ₀		~Kg ~lb	PED 2014/68/EU	
		mm	inch	mm	inch	mm	inch	daN	lb	daN	lb	daN	lb	cm ³	in ³			
RS 6600 - 013 - A	◆ RS 6600 - 013 - B	13	0.51	100	3.94	87	3.43	6630 ± 5% 14904 150 bar 2175 psi + 20 °C +68 °F		8547	19215	9724	21861	298	18.19	5,06	11.16	✓
RS 6600 - 016 - A	◆ RS 6600 - 016 - B	16	0.63	106	4.17	90	3.54			8826	19843	10148	22814	330	20.14	5,17	11.40	✓
RS 6600 - 022 - A	RS 6600 - 022 - B	22	0.87	118	4.65	96	3.78			9282	20867	10850	24391	394	24.04	5,42	11.95	✓
RS 6600 - 029 - A	RS 6600 - 029 - B	29	1.14	132	5.20	103	4.06			9690	21784	11488	25825	469	28.62	5,69	12.54	✓
RS 6600 - 035 - A	RS 6600 - 035 - B	35	1.38	144	5.67	109	4.29			9967	22406	11925	26808	533	32.53	5,93	13.07	✓
RS 6600 - 047 - A	RS 6600 - 047 - B	47	1.85	168	6.61	121	4.76			10385	23346	12593	28311	660	40.28	6,40	14.11	✓
RS 6600 - 060 - A	RS 6600 - 060 - B	60	2.36	194	7.64	134	5.28			10707	24071	13115	29485	799	48.76	6,90	15.21	✓
RS 6600 - 072 - A	RS 6600 - 072 - B	72	2.83	218	8.58	146	5.75			10930	24571	13479	30301	927	56.57	7,40	16.31	✓
RS 6600 - 077 - A	RS 6600 - 077 - B	77	3.03	228	8.98	151	5.94			11007	24746	13606	30587	980	59.80	7,60	16.76	✓
RS 6600 - 097 - A	RS 6600 - 097 - B	97	3.82	268	10.55	171	6.73			11255	25302	14013	31503	1193	72.80	8,40	18.52	✓
RS 6600 - 122 - A	RS 6600 - 122 - B	122	4.80	318	12.52	196	7.72	11471	25787	14371	32307	1459	89.03	9,40	20.72	✓		

◆ Disposable

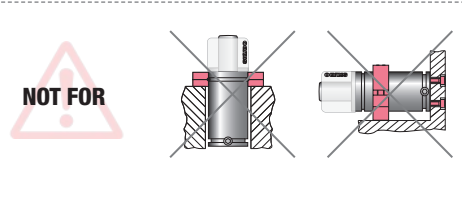
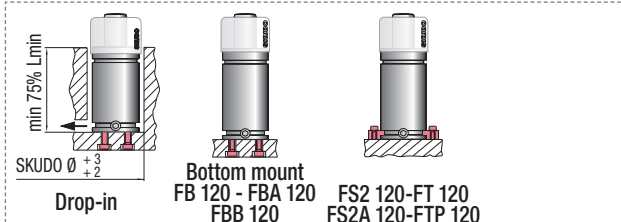
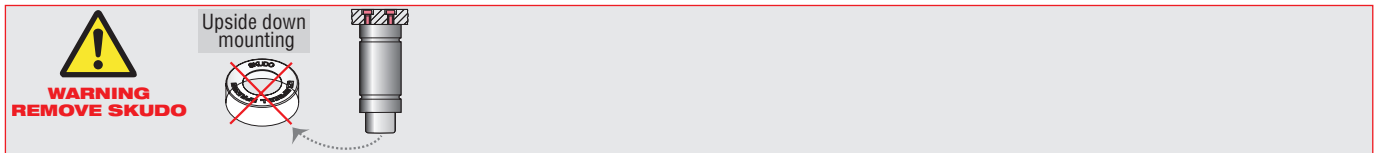

HOW TO ORDER
p. 73

INSTALLATION GUIDELINE
p. 205



ACTIVE SAFETY



OSAS



USAS



OPAS



SKUDO

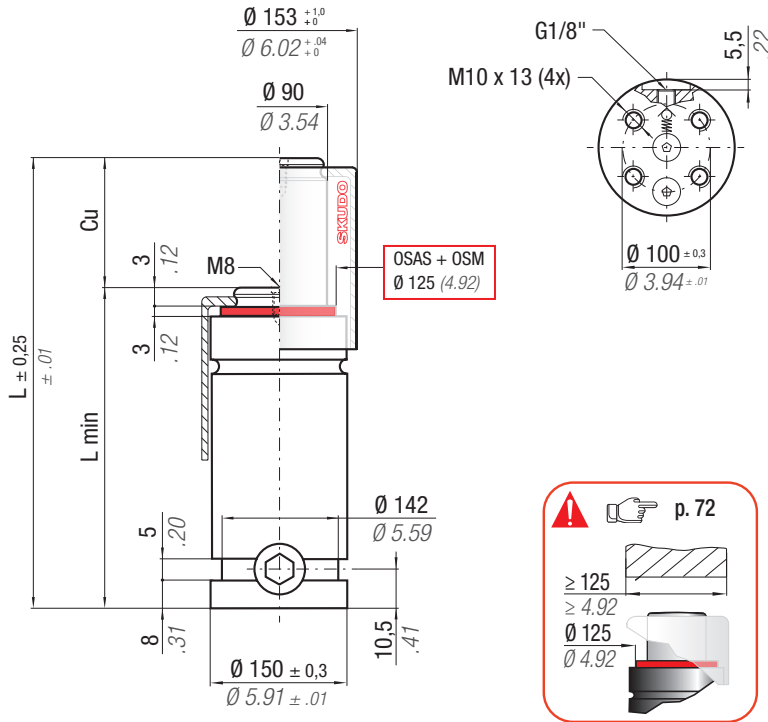

OSAS + OSM = OVER STROKE ACTIVE SAFETY + OVER STROKE MARKER

Il nuovo codice sarà fornito solo ad esaurimento del vecchio
 The new code will be supplied only when the old will be out of stock
 Der neue Kode wird nur angegeben, wenn der alte nicht mehr lieferbar ist
 Le nouveau code sera fourni uniquement lorsque le vieux stock sera écoulé
 El nuevo código será suministrado sólo cuando se agoten las existencias del antiguo
 O novo código irá ser fornecido apenas quando o antigo esgotar stock

easu MANIFOLD p. 247

p. 262

* F_{1i} = Isothermal end force at 100% Cu

p. 16

** F_{1p} = Polytrophic end force at 100% Cu

p. 16

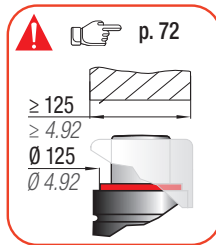

	0 - 80 °C 32 - 176 °F	ΔP $\pm 0,33 \% / ^\circ C$	P max 150 bar 2175 psi	P min 20 bar 290 psi	S 63,62 cm ² 9.864 in ²	SPM ~ 20 - 100 (at 20°C)	Max Speed 1,8 m/s 70.8 in/s	Maintenance kit 39BMRV09500C
--	--------------------------	----------------------------------------	-------------------------------------	-----------------------------------	------------------------------------------------------------	---------------------------------------	------------------------------------------	----------------------------------------

CODE PHASING OUT from 04/2021	NEW	Cu		L		L min		F ₀ Initial force		F _{1i} * End force *		F _{1p} ** End force **		V ₀		PED 2014/68/EU		
		mm	inch	mm	inch	mm	inch	daN	lb	daN	lb	daN	lb	cm ³	in ³	~Kg	~lb	✓
RS 9500 - 016 - A	◆ RS 9500 - 016 - B	16	0.63	116	4.57	100	3.94	9540 ± 5% 150 bar 2175 psi + 20 °C +68 °F	21446	12414	27908	14164	31841	513	31.31	9,51	20.97	✓
RS 9500 - 022 - A	◆ RS 9500 - 022 - B	22	0.87	128	5.04	106	4.17			13018	29265	15085	33913	609	37.16	9,90	21.83	✓
RS 9500 - 029 - A	RS 9500 - 029 - B	29	1.14	142	5.59	113	4.45			13561	30487	15927	35805	721	44.00	10,30	22.71	✓
RS 9500 - 035 - A	RS 9500 - 035 - B	35	1.38	154	6.06	119	4.69			13930	31317	16505	37105	818	49.92	10,70	23.59	✓
RS 9500 - 047 - A	RS 9500 - 047 - B	47	1.85	178	7.01	131	5.16			14491	32578	17393	39102	1010	61.63	11,40	25.13	✓
RS 9500 - 060 - A	RS 9500 - 060 - B	60	2.36	204	8.03	144	5.67			14926	33555	18090	40667	1218	74.33	12,20	26.90	✓
RS 9500 - 072 - A	RS 9500 - 072 - B	72	2.83	228	8.98	156	6.14			15227	34231	18575	41758	1410	86.04	13,00	28.66	✓
RS 9500 - 077 - A	RS 9500 - 077 - B	77	3.03	238	9.37	161	6.34			15332	34467	18745	42140	1491	90.99	13,30	29.32	✓
RS 9500 - 097 - A	RS 9500 - 097 - B	97	3.82	278	10.94	181	7.13			15667	35221	19292	43370	1811	110.51	14,60	32.19	✓
RS 9500 - 122 - A	RS 9500 - 122 - B	122	4.80	328	12.91	206	8.11			15961	35881	19773	44451	2212	134.98	16,10	35.49	✓

◆ Disposable

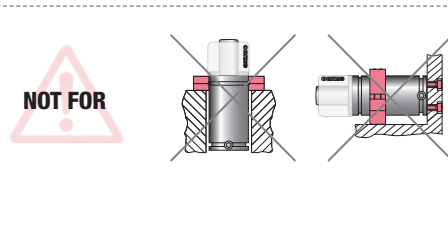
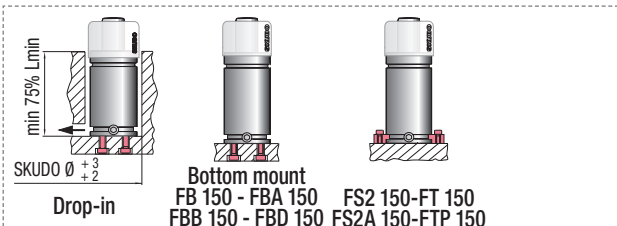
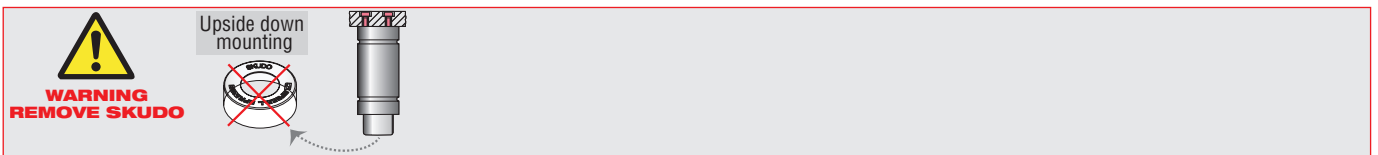

HOW TO ORDER
 p. 73
INSTALLATION GUIDELINE
 p. 205

FCA		

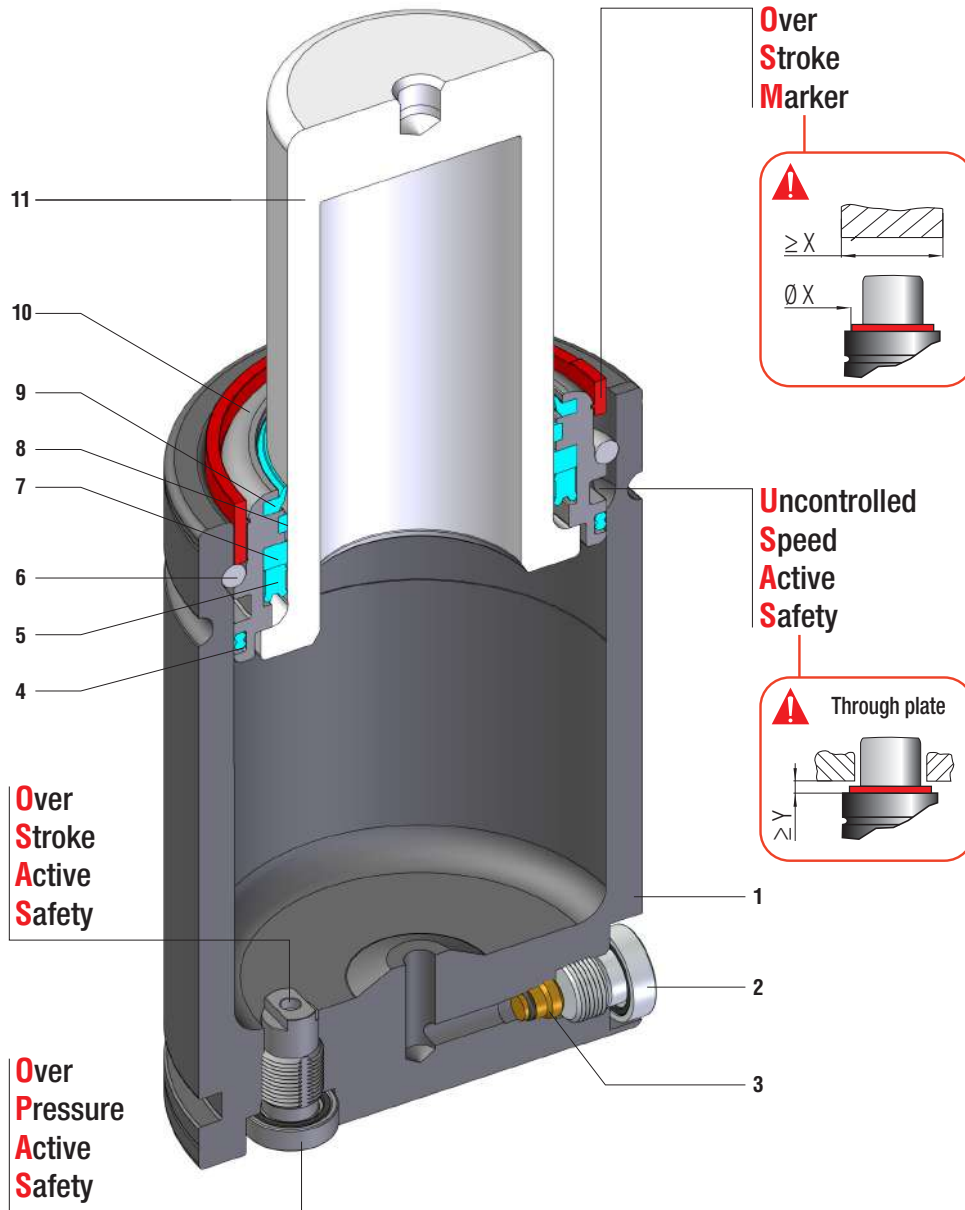

Minima altezza, massima forza, collegabili G1/8 - Minimum height, maximum force, hose cylinders with G1/8 charging port
 Minimale Höhe, maximale Kraft, Gdf. mit G1/8 Öffnung verbindbar - Hauteur minimale, force maximale, cylindres raccordés avec trou G1/8 gaz
 Mínima altura, máxima fuerza, cilindros conectados con agujero G1/8 gas - Altura mínima, força máxima, cilindros conectados com furo G1/8 gás

SEALING	ROD SEAL
DESIGN	BUSH - BODY DESIGN

1	Body	5	Rod seal	9	Rod wiper
2	Plug	6	Retaining ring	10	Bush
3	Valve	7	Back-up ring	11	Rod (nitrited superfinished)
4	Dual ring seal	8	Guide ring		

RANGE CHART

Model	Body Ø		Stroke Cu		Initial force F0								
	mm	inch	mm	inch	daN	lb	OSAS	USAS	OPAS	SKUDO	SW		
RF 750	45	1.77	10 - 125	0.39 - 4.92	740	1664	✓	✓	✓	-	✓		
RF 1000	50	1.97	13 - 125	0.51 - 4.92	920	2068	✓	✓	✓	-	✓		
RF 1200	50	1.97	13 - 125	0.51 - 4.92	1047	2354	✓	✓	✓	-	✓		
RF 1500	63	2.48	13 - 125	0.51 - 4.92	1530	3440	✓	✓	✓	-	✓		
RF 2400	75	2.95	16 - 125	0.63 - 4.92	2385	5362	✓	✓	✓	-	✓		
	95	3.74	RV series									✓	✓
	120	4.72										✓	✓
	150	5.91										✓	✓
	150	5.91										✓	✓
	195	7.68										✓	✓

Built-in as standard
 Optional upon request

RF

HOW TO ORDER



Available versions

RF 2400-050-B Standard code	RF 2400-050-B-W Add "-W" to standard code	RF 2400-050-B-N Add "-N" to standard code	RF 2400-050-B-N-W Add "-N-W" to standard code	RF 2400-050-B-E Add "-E" to standard code	RF 2400-050-B-E-W Add "-E-W" to standard code
Self contained	Self contained + Secondary wiper	Linkable	Linkable + Secondary wiper	Easy Manifold	Easy Manifold + Secondary wiper



OSAS + OSM = OVER STROKE ACTIVE SAFETY + OVER STROKE MARKER

ACTIVE SAFETY



OSAS



USAS



OPAS

Il nuovo codice sarà fornito solo ad esaurimento del vecchio

The new code will be supplied only when the old will be out of stock

Der neue Kode wird nur angegeben, wenn der alte nicht mehr lieferbar ist

Le nouveau code sera fourni uniquement lorsque le vieux stock sera écoulé

El nuevo código será suministrado sólo cuando se agoten las existencias del antiguo

O novo código irá ser fornecido apenas quando o antigo esgotar stock

easU MANIFOLD p. 247

p. 262

* F_{1i} = Isothermal end force at 100% Cu p. 16

** F_{1p} = Polytrophic end force at 100% Cu

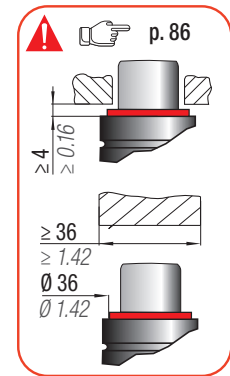
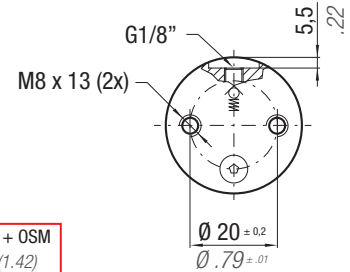
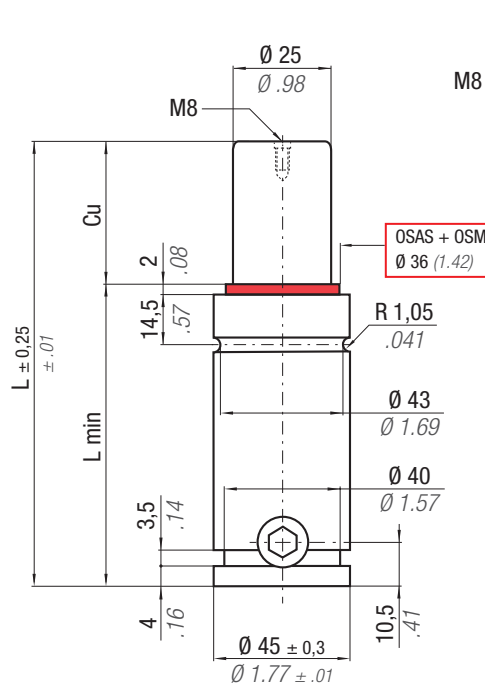

	0 - 80 °C 32 - 176 °F	ΔP ± 0,33 %/°C	P max 150 bar 2175 psi	P min 20 bar 290 psi	S 4,91 cm ² 0,761 in ²	SPM ~ 20 - 100 (at 20°C)	Max Speed 1,8 m/s 70,8 in/s	Maintenance kit 39BMRV00750C
--	--------------------------	---------------------------	-------------------------------------	-----------------------------------	-----------------------------------------------------------	---------------------------------------	------------------------------------------	----------------------------------------

CODE PHASING OUT from 04/2021	NEW	Cu		L		L min		F ₀		F _{1i} *		F _{1p} **		V ₀		~Kg	~lb	PED 2014/68/EU
		mm	inch	mm	inch	mm	inch	daN	lb	daN	lb	daN	lb	cm ³	in ³			
RF 750 - 010 - A	♦ RF 750 - 010 - B	10	0.39	62	2.44	52	2.05	740 ± 5%	1664	1118	2514	1343	3018	16,6	1.01	0,47	1.04	✓
RF 750 - 013 - A	RF 750 - 013 - B	13	0.51	68	2.68	55	2.17			1152	2590	1396	3139	20,4	1.24	0,48	1.06	✓
RF 750 - 016 - A	RF 750 - 016 - B	16	0.63	74	2.91	58	2.28			1176	2644	1435	3227	24,1	1.47	0,50	1.10	✓
RF 750 - 019 - A	RF 750 - 019 - B	19	0.75	80	3.15	61	2.40			1194	2685	1465	3293	27,9	1.70	0,52	1.15	✓
RF 750 - 025 - A	RF 750 - 025 - B	25	0.98	92	3.62	67	2.64			1220	2743	1507	3388	35,5	2.17	0,56	1.23	✓
RF 750 - 032 - A	RF 750 - 032 - B	32	1.26	106	4.17	74	2.91			1240	2787	1539	3460	44,3	2.70	0,61	1.34	✓
RF 750 - 038 - A	RF 750 - 038 - B	38	1.50	118	4.65	80	3.15			1251	2813	1558	3503	51,9	3.17	0,65	1.43	✓
RF 750 - 050 - A	RF 750 - 050 - B	50	1.97	142	5.59	92	3.62			1267	2848	1584	3562	67,0	4.09	0,72	1.59	✓
RF 750 - 063 - A	RF 750 - 063 - B	63	2.48	168	6.61	105	4.13			1278	2873	1602	3602	83,4	5.09	0,81	1.79	✓
RF 750 - 075 - A	RF 750 - 075 - B	75	2.95	192	7.56	117	4.61			1285	2888	1614	3628	98,5	6.01	0,88	1.94	✓
RF 750 - 080 - A	RF 750 - 080 - B	80	3.15	202	7.95	122	4.80			1287	2893	1618	3637	104,8	6.40	0,92	2.03	✓
RF 750 - 100 - A	RF 750 - 100 - B	100	3.94	242	9.53	142	5.59			1294	2909	1629	3663	130,1	7.94	1,04	2.29	✓
RF 750 - 125 - A	RF 750 - 125 - B	125	4.92	292	11.50	167	6.57			1300	2922	1639	3685	161,6	9.86	1,21	2.67	✓

♦ Disposable

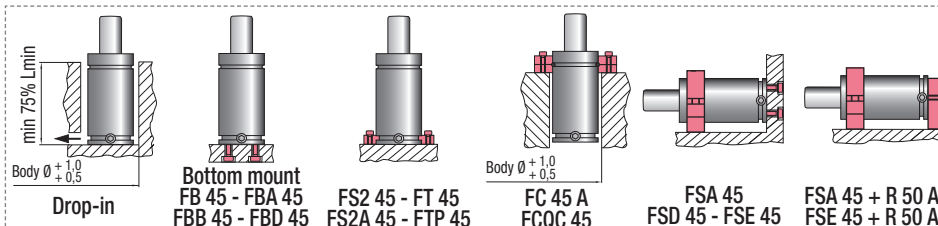

HOW TO ORDER
 p. 87

INSTALLATION GUIDELINE
 p. 205



SW

ACTIVE SAFETY



OSAS



USAS

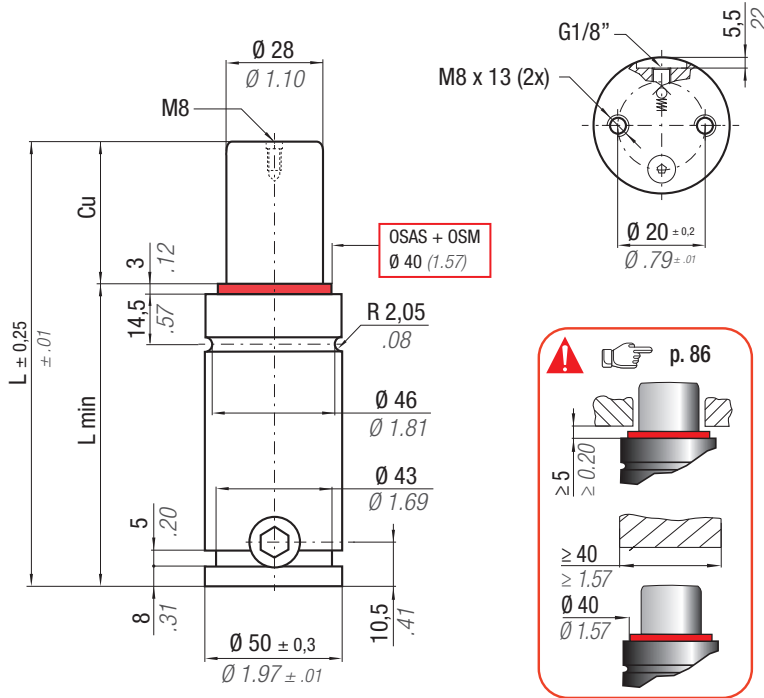

OPAS

OSAS + OSM = OVER STROKE ACTIVE SAFETY + OVER STROKE MARKER

Il nuovo codice sarà fornito solo ad esaurimento del vecchio

The new code will be supplied only when the old will be out of stock

Der neue Kode wird nur angegeben, wenn der alte nicht mehr lieferbar ist

Le nouveau code sera fourni uniquement lorsque le vieux stock sera épuisé

El nuevo código será suministrado sólo cuando se agoten las existencias del antiguo

O novo código irá ser fornecido apenas quando o antigo esgotar stock

 * F_{1i} =

Isothermal end force at 100% Cu

p. 16

 ** F_{1p} =

Polytrophic end force at 100% Cu

RF

N ₂		0 - 80 °C 32 - 176 °F	ΔP ± 0,33 %/°C	P max 150 bar 2175 psi	P min 20 bar 290 psi	S 6,15 cm ² 0.953 in ²	SPM ~ 20 - 100 (at 20°C)	Max Speed 1,8 m/s 70.8 in/s	Maintenance kit 39BMRV01000C		
CODE	NEW	Cu	L	L min	F ₀	F _{1i} *	F _{1p} **	V ₀	PED 2014/68/EU		
PHASING OUT from 04/2021		mm inch	mm inch	mm inch	Initial force daN lb	End force * daN lb	End force ** daN lb	cm ³ in ³	~Kg ~lb	~lb	
RF 1000 - 013 - A	◆ RF 1000 - 013 - B	13 0.51	74 2.91	61 2.40	920 2068 ± 5%	1370 3079	1631 3667	28,4 1.73	0,65 1.43	✓	
RF 1000 - 016 - A	RF 1000 - 016 - B	16 0.63	80 3.15	64 2.52		1407 3163	1690 3800	33,1 2.02	0,68 1.50	✓	
RF 1000 - 019 - A	RF 1000 - 019 - B	19 0.75	86 3.39	67 2.64		1436 3229	1737 3906	37,7 2.30	0,70 1.54	✓	
RF 1000 - 025 - A	RF 1000 - 025 - B	25 0.98	98 3.86	73 2.87		1479 3326	1807 4062	47,1 2.87	0,75 1.65	✓	
RF 1000 - 032 - A	RF 1000 - 032 - B	32 1.26	112 4.41	80 3.15		1514 3403	1863 4187	58,0 3.54	0,81 1.79	✓	
RF 1000 - 038 - A	RF 1000 - 038 - B	38 1.50	124 4.88	86 3.39		1535 3451	1897 4266	67,4 4.11	0,85 1.87	✓	
RF 1000 - 050 - A	RF 1000 - 050 - B	50 1.97	148 5.83	98 3.86		1564 3517	1946 4375	86,1 5.25	0,95 2.09	✓	
RF 1000 - 063 - A	RF 1000 - 063 - B	63 2.48	174 6.85	111 4.37		1585 3564	1981 4453	106,3 6.49	1,05 2.31	✓	
RF 1000 - 075 - A	RF 1000 - 075 - B	75 2.95	198 7.80	123 4.84		+ 20 °C +68 °F	1599 3594	2003 4503	125,0 7.63	1,15 2.54	✓
RF 1000 - 080 - A	RF 1000 - 080 - B	80 3.15	208 8.19	128 5.04		1603 3605	2011 4520	132,8 8.10	1,19 2.62	✓	
RF 1000 - 100 - A	RF 1000 - 100 - B	100 3.94	248 9.76	148 5.83	1618 3636	2034 4573	164,0 10.01	1,35 2.98	✓		
RF 1000 - 125 - A	RF 1000 - 125 - B	125 4.92	298 11.73	173 6.81	1629 3663	2054 4617	202,9 12.38	1,55 3.42	✓		

◆ Disposable

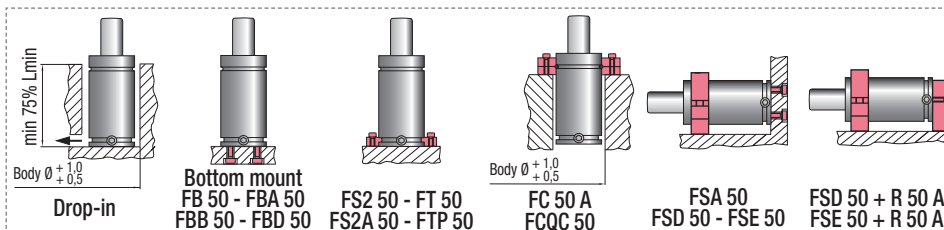
HOW TO ORDER

p. 87

INSTALLATION GUIDELINE

p. 205



OSAS + OSM = OVER STROKE ACTIVE SAFETY + OVER STROKE MARKER

ACTIVE SAFETY



OSAS



USAS



OPAS

Il nuovo codice sarà fornito solo ad esaurimento del vecchio
 The new code will be supplied only when the old will be out of stock
 Der neue Kode wird nur angegeben, wenn der alte nicht mehr lieferbar ist
 Le nouveau code sera fourni uniquement lorsque le vieux stock sera épuisé
 El nuevo código será suministrado sólo cuando se agoten las existencias del antiguo
 O novo código irá ser fornecido apenas quando o antigo esgotar stock



* F_{1i} = Isothermal end force at 100% Cu p. 16
 ** F_{1p} = Polytrophic end force at 100% Cu

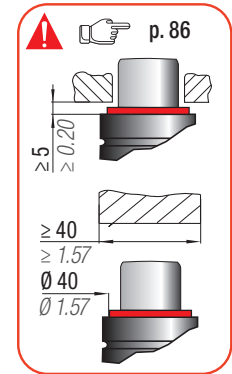
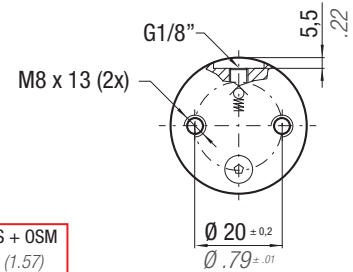
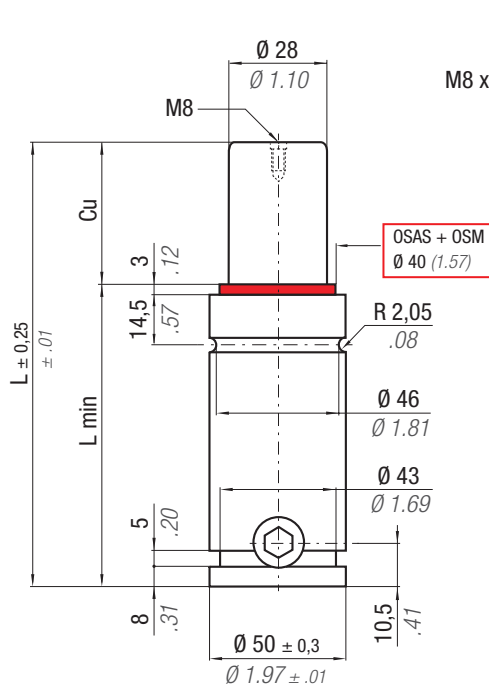

N ₂		0 - 80 °C 32 - 176 °F	ΔP ± 0,33 %/°C	P max 170 bar 2465 psi	P min 20 bar 290 psi	S 6,15 cm ² 0,953 in ²	SPM ~ 20 - 100 (at 20°C)	Max Speed 1,8 m/s 70,8 in/s	Maintenance kit 39BMRV01000C	
CODE PHASING OUT from 04/2021	NEW	Cu	L	L min	F ₀	F _{1i} *	F _{1p} **	V ₀		
		mm inch	mm inch	mm inch	daN lb	daN lb	daN lb	cm ³ in ³	~Kg ~lb	
RF 1200 - 013 - A	♦ RF 1200 - 013 - B	13 0.51	74 2.91	61 2.40	1047 2354 ± 5% 170 bar 2465 psi + 20 °C +68 °F	1577 3546	1839 4135	28,4 1.73	0,65 1.43	✓
RF 1200 - 016 - A	RF 1200 - 016 - B	16 0.63	80 3.15	64 2.52		1622 3646	1906 4284	33,1 2.02	0,68 1.50	✓
RF 1200 - 019 - A	RF 1200 - 019 - B	19 0.75	86 3.39	67 2.64		1657 3725	1959 4403	37,7 2.30	0,70 1.54	✓
RF 1200 - 025 - A	RF 1200 - 025 - B	25 0.98	98 3.86	73 2.87		1709 3841	2037 4579	47,1 2.87	0,75 1.65	✓
RF 1200 - 032 - A	RF 1200 - 032 - B	32 1.26	112 4.41	80 3.15		1750 3934	2100 4721	58,0 3.54	0,81 1.79	✓
RF 1200 - 038 - A	RF 1200 - 038 - B	38 1.50	124 4.88	86 3.39		1776 3992	2139 4809	67,4 4.11	0,85 1.87	✓
RF 1200 - 050 - A	RF 1200 - 050 - B	50 1.97	148 5.83	98 3.86		1811 4072	2194 4932	86,1 5.25	0,95 2.09	✓
RF 1200 - 063 - A	RF 1200 - 063 - B	63 2.48	174 6.85	111 4.37		1836 4128	2233 5020	106,3 6.49	1,05 2.31	✓
RF 1200 - 075 - A	RF 1200 - 075 - B	75 2.95	198 7.80	123 4.84		1853 4165	2258 5077	125,0 7.63	1,15 2.54	✓
RF 1200 - 080 - A	RF 1200 - 080 - B	80 3.15	208 8.19	128 5.04		1858 4177	2267 5096	132,8 8.10	1,19 2.62	✓
RF 1200 - 100 - A	RF 1200 - 100 - B	100 3.94	248 9.76	148 5.83	1875 4215	2293 5156	164,0 10.01	1,35 2.98	✓	
RF 1200 - 125 - A	RF 1200 - 125 - B	125 4.92	298 11.73	173 6.81	1889 4247	2315 5205	202,9 12.38	1,55 3.42	✓	

♦ Disposable

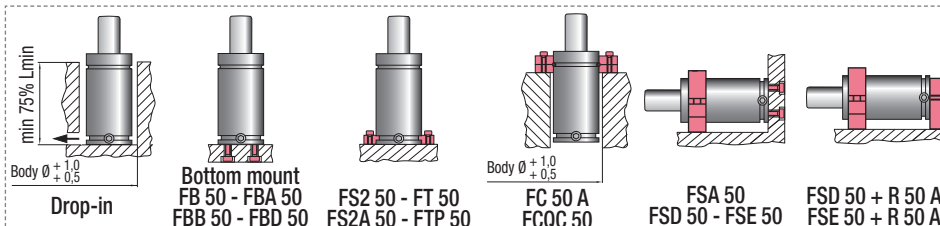

HOW TO ORDER
 p. 87

INSTALLATION GUIDELINE
 p. 205

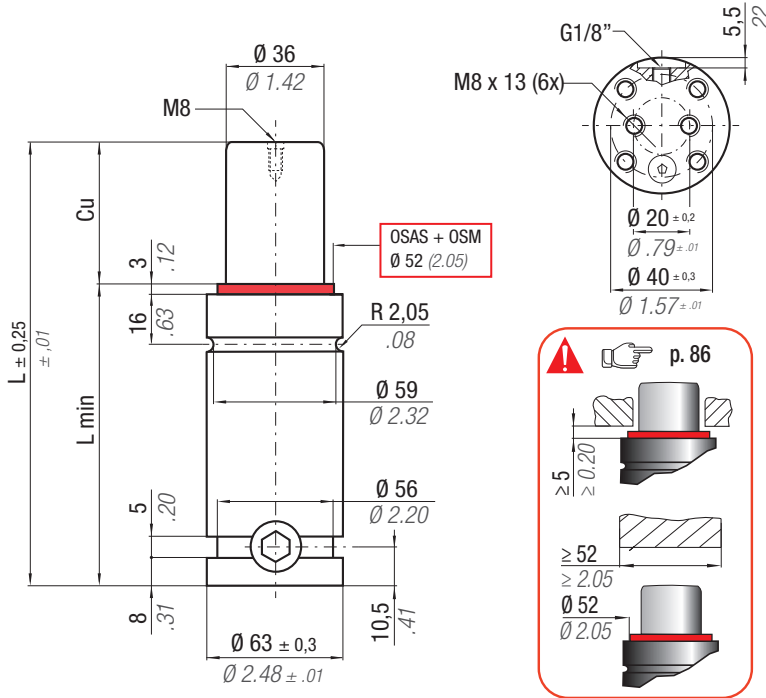

OSAS + OSM = OVER STROKE ACTIVE SAFETY + OVER STROKE MARKER



ACTIVE SAFETY



OSAS



USAS



OPAS

Il nuovo codice sarà fornito solo ad esaurimento del vecchio

The new code will be supplied only when the old will be out of stock

Der neue Kode wird nur angegeben, wenn der alte nicht mehr lieferbar ist

Le nouveau code sera fourni uniquement lorsque le vieux stock sera écoulé

El nuevo código será suministrado sólo cuando se agoten las existencias del antiguo

O novo código irá ser fornecido apenas quando o antigo esgotar stock



* $F_{1i} =$

Isothermal end force at 100% Cu

p. 16

** $F_{1p} =$

Polytrophic end force at 100% Cu

RF

N ₂		0 - 80 °C 32 - 176 °F	ΔP ± 0,33 %/°C	P max 150 bar 2175 psi	P min 20 bar 290 psi	S 10,18 cm ² 1.578 in ²	SPM ~ 20 - 100 (at 20°C)	Max Speed 1,8 m/s 70.8 in/s	Maintenance kit 39BMRV01500C	
CODE	NEW	Cu	L	L min	F ₀	F _{1i} *	F _{1p} **	V ₀		
PHASING OUT from 04/2021		mm inch	mm inch	mm inch	Initial force daN lb	End force * daN lb	End force ** daN lb	cm ³ in ³	~Kg ~lb	
RF 1500 - 013 - B	◆ RF 1500 - 013 - C	13 0.51	80 3.15	67 2.64	1530 3440 ± 5%	2168 4874	2546 5723	52 3.17	1,15 2.54	
RF 1500 - 016 - B	RF 1500 - 016 - C	16 0.63	86 3.39	70 2.76		2230 5012	2642 5939	60 3.66	1,18 2.60	
RF 1500 - 019 - B	RF 1500 - 019 - C	19 0.75	92 3.62	73 2.87		2279 5123	2720 6114	68 4.15	1,22 2.69	
RF 1500 - 025 - B	RF 1500 - 025 - C	25 0.98	104 4.09	79 3.11		2353 5290	2838 6380	84 5.13	1,29 2.84	
RF 1500 - 032 - B	RF 1500 - 032 - C	32 1.26	118 4.65	86 3.39		2414 5426	2935 6599	102 6.22	1,37 3.02	
RF 1500 - 038 - B	RF 1500 - 038 - C	38 1.50	130 5.12	92 3.62		2452 5512	2997 6738	118 7.20	1,44 3.17	
RF 1500 - 050 - B	RF 1500 - 050 - C	50 1.97	154 6.06	104 4.09		2506 5633	3085 6935	149 9.09	1,58 3.48	
RF 1500 - 063 - B	RF 1500 - 063 - C	63 2.48	180 7.09	117 4.61		2544 5720	3148 7078	184 11.23	1,74 3.84	
RF 1500 - 075 - B	RF 1500 - 075 - C	75 2.95	204 8.03	129 5.08		+ 20 °C +68 °F	2570 5777	3190 7172	215 13.12	1,88 4.14
RF 1500 - 080 - B	RF 1500 - 080 - C	80 3.15	214 8.43	134 5.28		2578 5797	3204 7204	229 13.97	1,94 4.28	
RF 1500 - 100 - B	RF 1500 - 100 - C	100 3.94	254 10.00	154 6.06	2605 5857	3249 7303	281 17.15	2,18 4.81		
RF 1500 - 125 - B	RF 1500 - 125 - C	125 4.92	304 11.97	179 7.05	2628 5907	3286 7387	347 21.18	2,47 5.45		

◆ Disposable

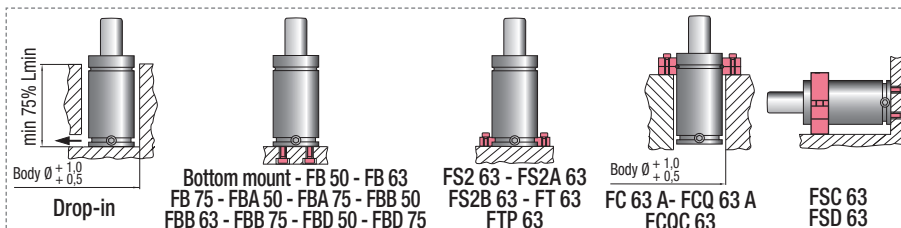

HOW TO ORDER

p. 87

INSTALLATION GUIDELINE

p. 205



OSAS + OSM = OVER STROKE ACTIVE SAFETY + OVER STROKE MARKER

ACTIVE SAFETY



OSAS



USAS



OPAS

Il nuovo codice sarà fornito solo ad esaurimento del vecchio
 The new code will be supplied only when the old will be out of stock
 Der neue Kode wird nur angegeben, wenn der alte nicht mehr lieferbar ist
 Le nouveau code sera fourni uniquement lorsque le vieux stock sera écoulé
 El nuevo código será suministrado sólo cuando se agoten las existencias del antiguo
 O novo código irá ser fornecido apenas quando o antigo esgotar stock

easu MANIFOLD p. 247 p. 262

* F_{1i} = Isothermal end force at 100% Cu p. 16
 ** F_{1p} = Polytrophic end force at 100% Cu

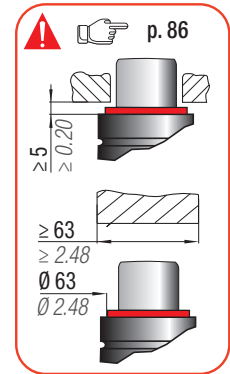
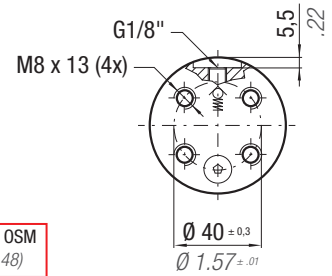
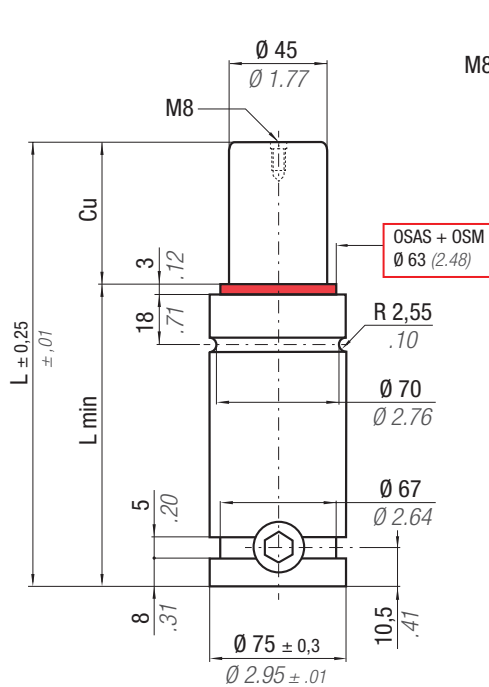

N₂		0 - 80 °C 32 - 176 °F	ΔP ± 0,33 %/°C	P max 150 bar 2175 psi	P min 20 bar 290 psi	S 15,90 cm ² 2,465 in ²	SPM ~ 20 - 100 (at 20°C)	Max Speed 1,8 m/s 70,8 in/s	Maintenance kit 39BMRV02400D	
CODE	NEW	Cu	L	L min	F ₀	F _{1i} *	F _{1p} **	V ₀		
PHASING OUT from 04/2021		mm inch	mm inch	mm inch	Initial force daN lb	End force * daN lb	End force ** daN lb	cm ³ in ³	~Kg ~lb	2014/68/EU
RF 2400 - 016 - A	♦ RF 2400 - 016 - B	16 0.63	87 3.43	71 2.80	2385 5362 ± 5% 150 bar 2175 psi + 20 °C +68 °F	3510 7891	4170 9374	92 5.61	1,68 3.70	✓
RF 2400 - 019 - A	♦ RF 2400 - 019 - B	19 0.75	93 3.66	74 2.91		3592 8075	4299 9665	104 6.35	1,73 3.81	✓
RF 2400 - 025 - A	RF 2400 - 025 - B	25 0.98	105 4.13	80 3.15		3716 8354	4498 10111	128 7.81	1,82 4.01	✓
RF 2400 - 032 - A	RF 2400 - 032 - B	32 1.26	119 4.69	87 3.43		3818 8583	4662 10481	156 9.52	1,93 4.25	✓
RF 2400 - 038 - A	RF 2400 - 038 - B	38 1.50	131 5.16	93 3.66		3883 8728	4767 10717	180 10.98	2,03 4.48	✓
RF 2400 - 050 - A	RF 2400 - 050 - B	50 1.97	155 6.10	105 4.13		3974 8935	4917 11054	228 13.91	2,21 4.87	✓
RF 2400 - 063 - A	RF 2400 - 063 - B	63 2.48	181 7.13	118 4.65		4041 9083	5026 11299	280 17.09	2,42 5.34	✓
RF 2400 - 075 - A	RF 2400 - 075 - B	75 2.95	205 8.07	130 5.12		4084 9181	5098 11461	328 20.02	2,61 5.75	✓
RF 2400 - 080 - A	RF 2400 - 080 - B	80 3.15	215 8.46	135 5.31		4099 9215	5123 11517	348 21.24	2,69 5.93	✓
RF 2400 - 100 - A	RF 2400 - 100 - B	100 3.94	255 10.04	155 6.10		4145 9318	5199 11688	428 26.12	3,00 6.61	✓
RF 2400 - 125 - A	RF 2400 - 125 - B	125 4.92	305 12.01	180 7.09	4183 9405	5264 11833	528 32.22	3,40 7.50	✓	

♦ Disposable

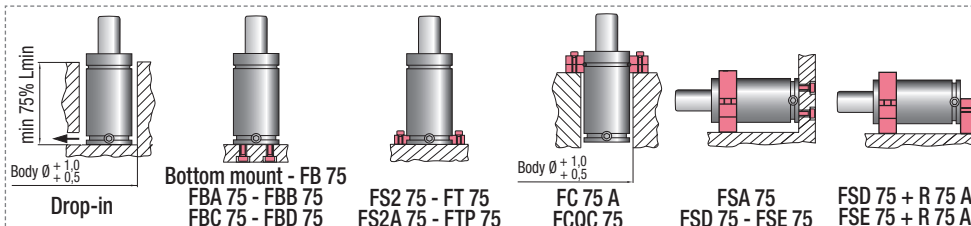

HOW TO ORDER
 p. 87

INSTALLATION GUIDELINE
 p. 205



THIS PAGE IS INTENTIONALLY LEFT BLANK



Nissan	Renault	

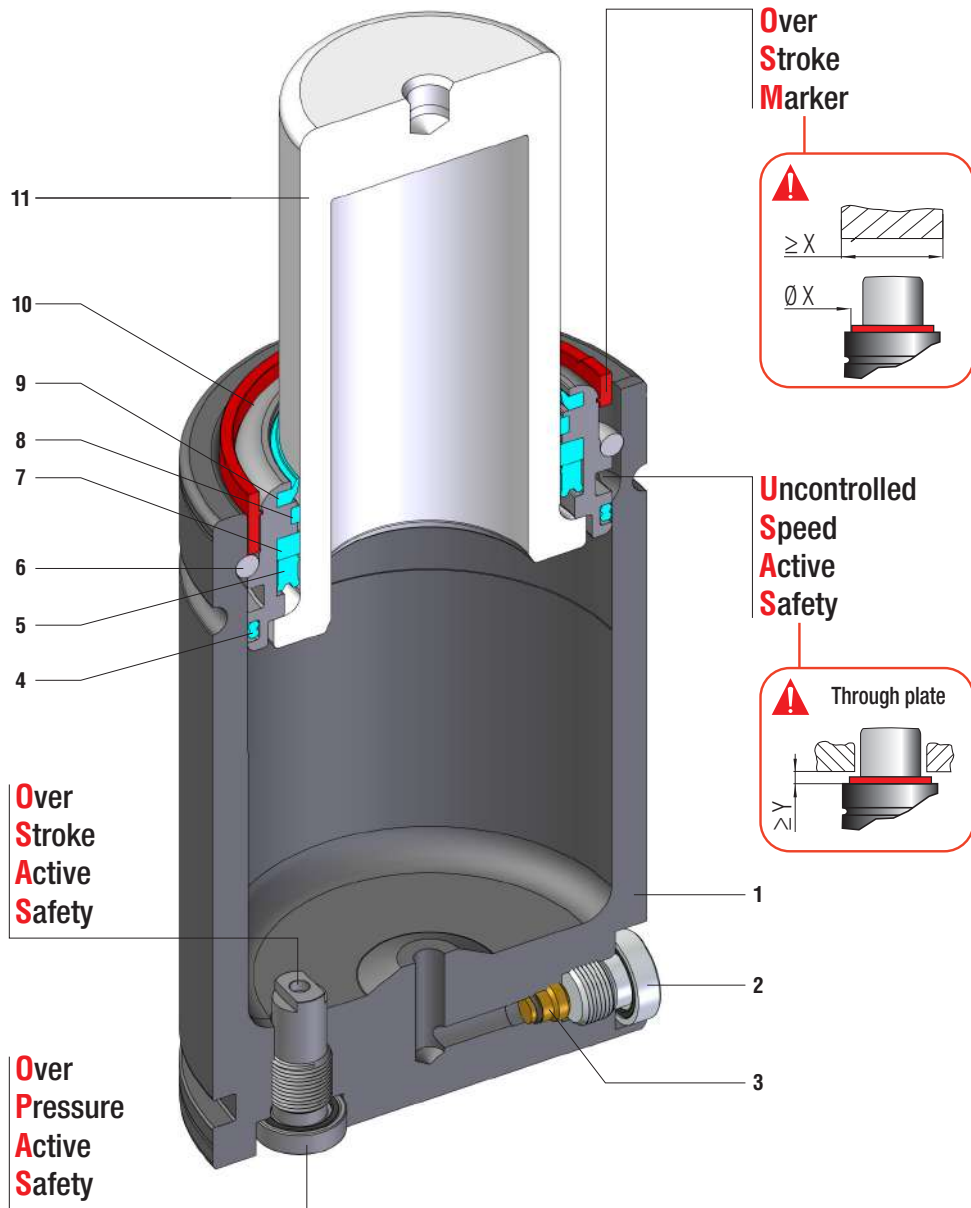

Minima altezza, massima forza, collegabili G1/8 - Minimum height, maximum force, hose cylinders with G1/8 charging port - Minimale Höhe, maximale Kraft, Gdf. mit G1/8 Öffnung verbindbar - Hauteur minimale, force maximale, cylindres raccordés avec trou G1/8 gaz - Mínima altura, máxima fuerza, cilindros conectados con agujero G1/8 gas - Altura mínima, força máxima, cilindros conectados com furo G1/8 gás

SEALING	ROD SEAL
DESIGN	BUSH - BODY DESIGN

1	Body	5	Rod seal	9	Rod wiper
2	Plug	6	Retaining ring	10	Bush
3	Valve	7	Back-up ring	11	Rod (nitrited superfinished)
4	Dual ring seal	8	Guide ring		

RANGE CHART

Model	Body Ø		Stroke Cu		Initial force F0						
	mm	inch	mm	inch	daN	lb	OSAS	USAS	OPAS	SKUDO	SW
RG 750	45	1.77	10 - 125	0.39 - 4.92	740	1664	✓	✓	✓	-	✓
RG 1000	50	1.97	10 - 125	0.39 - 4.92	920	2068	✓	✓	✓	-	✓
RG 1500	63	2.48	10 - 125	0.39 - 4.92	1530	3440	✓	✓	✓	-	✓
RG 2400	75	2.95	10 - 125	0.39 - 4.92	2385	5362	✓	✓	✓	-	✓
RG 4200	95	3.74	16 - 125	0.63 - 4.92	4240	9532	✓	✓	✓	-	✓
RG 6600	120	4.72	16 - 125	0.63 - 4.92	6630	14905	✓	✓	✓	-	✓

✓ Built-in as standard ✓ Optional upon request

RG

HOW TO ORDER



Available versions

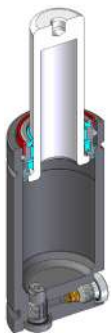

RG 2400-050-B
Standard code

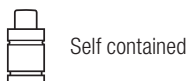

RG 2400-050-B-W
Add "-W" to standard code

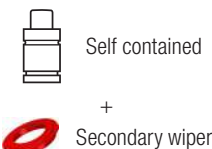

RG 2400-050-B-N
Add "-N" to standard code

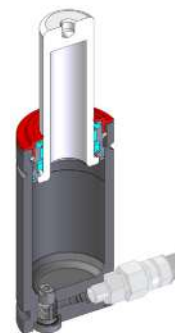

RG 2400-050-B-N-W
Add "-N-W" to standard code

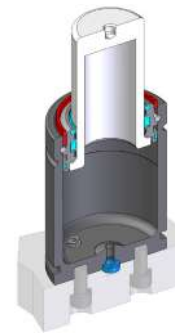
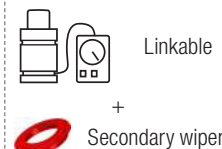

RG 2400-050-B-E
Add "-E" to standard code

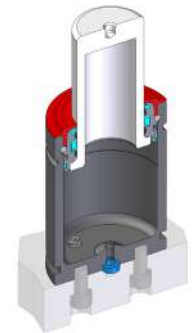

RG 2400-050-B-E-W
Add "-E-W" to standard code

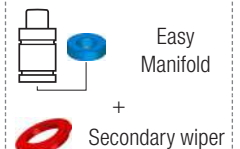



OSAS + OSM = OVER STROKE ACTIVE SAFETY + OVER STROKE MARKER

ACTIVE SAFETY



OSAS



USAS



OPAS

Il nuovo codice sarà fornito solo ad esaurimento del vecchio
 The new code will be supplied only when the old will be out of stock
 Der neue Kode wird nur angegeben, wenn der alte nicht mehr lieferbar ist
 Le nouveau code sera fourni uniquement lorsque le vieux stock sera écoulé
 El nuevo código será suministrado sólo cuando se agoten las existencias del antiguo
 O novo código irá ser fornecido apenas quando o antigo esgotar stock



* F_{1i} = Isothermal end force at 100% Cu p. 16
 ** F_{1p} = Polytrophic end force at 100% Cu p. 16

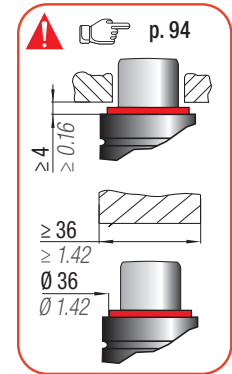
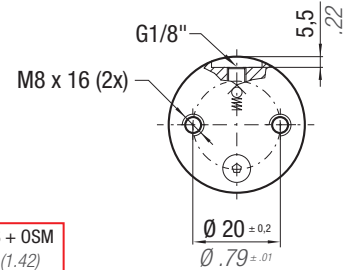
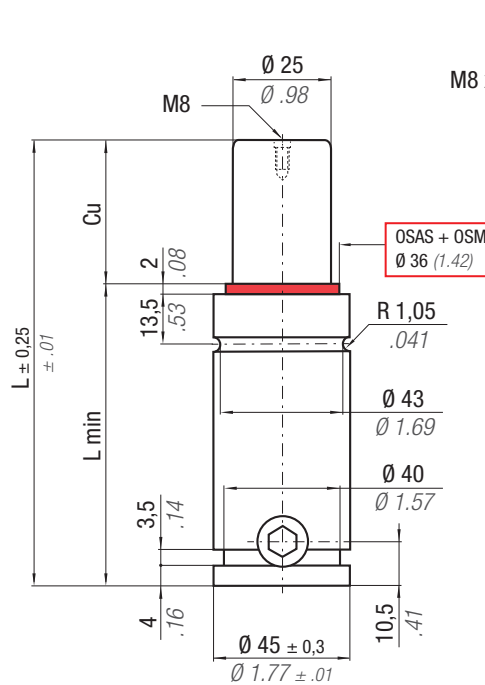

	0 - 80 °C 32 - 176 °F	ΔP ± 0,33 %/°C	P max 150 bar 2175 psi	P min 20 bar 290 psi	S 4,91 cm ² 0,761 in ²	SPM ~ 20 - 100 (at 20°C)	Max Speed 1,8 m/s 70,8 in/s	Maintenance kit 39BMRV00750C
--	--------------------------	---------------------------	------------------------------	----------------------------	----------------------------------------------------	--------------------------------	-----------------------------------	---------------------------------

CODE PHASING OUT from 04/2021	NEW	Cu		L		L min		F ₀		F _{1i} *		F _{1p} **		V ₀		~Kg	~lb	PED 2014/68/EU
		mm	inch	mm	inch	mm	inch	daN	lb	daN	lb	daN	lb	cm ³	in ³			
RG 750 - 010 - A	◆ RG 750 - 010 - B	10	0.39	67	2.64	57	2.24	740 ± 5%	1664	1026	2307	1198	2693	20,2	1.23	0,50	1.10	✓
RG 750 - 013 - A	◆ RG 750 - 013 - B	13	0.51	73	2.87	60	2.36			1065	2394	1258	2828	23,9	1.46	0,52	1.15	✓
RG 750 - 016 - A	RG 750 - 016 - B	16	0.63	79	3.11	63	2.48			1095	2461	1305	2933	27,7	1.69	0,54	1.19	✓
RG 750 - 019 - A	RG 750 - 019 - B	19	0.75	85	3.35	66	2.60			1118	2514	1342	3017	31,5	1.92	0,56	1.23	✓
RG 750 - 025 - A	RG 750 - 025 - B	25	0.98	97	3.82	72	2.83			1153	2593	1398	3143	39,1	2.39	0,60	1.32	✓
RG 750 - 032 - A	RG 750 - 032 - B	32	1.26	111	4.37	79	3.11			1182	2656	1444	3246	47,9	2.92	0,64	1.41	✓
RG 750 - 038 - A	RG 750 - 038 - B	38	1.50	123	4.84	85	3.35			1199	2696	1473	3311	55,5	3.39	0,68	1.50	✓
RG 750 - 050 - A	RG 750 - 050 - B	50	1.97	147	5.79	97	3.82			1224	2752	1514	3403	70,6	4.31	0,76	1.68	✓
RG 750 - 063 - A	RG 750 - 063 - B	63	2.48	173	6.81	110	4.33			1242	2792	1543	3468	87,0	5.31	0,84	1.85	✓
RG 750 - 075 - A	RG 750 - 075 - B	75	2.95	197	7.76	122	4.80			1253	2818	1562	3511	102,1	6.23	0,92	2.03	✓
RG 750 - 080 - A	RG 750 - 080 - B	80	3.15	207	8.15	127	5.00			1257	2827	1568	3526	108,4	6.61	0,95	2.09	✓
RG 750 - 100 - A	RG 750 - 100 - B	100	3.94	247	9.72	147	5.79			1269	2854	1588	3571	133,7	8.16	1,08	2.38	✓
RG 750 - 125 - A	RG 750 - 125 - B	125	4.92	297	11.69	172	6.77			1280	2877	1605	3609	165,2	10.08	1,24	2.73	✓

◆ Disposable

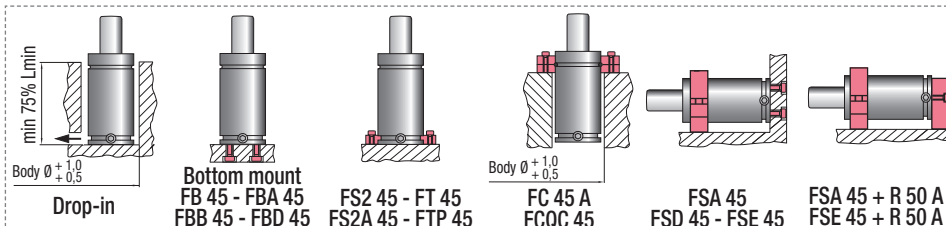

HOW TO ORDER
 p. 95

INSTALLATION GUIDELINE
 p. 205



ACTIVE SAFETY



OSAS



USAS



OPAS

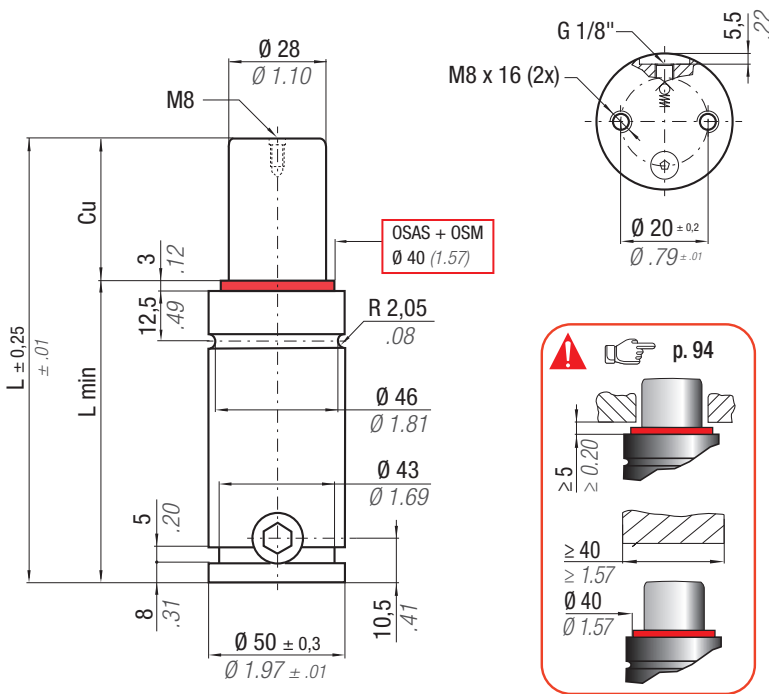

OSAS + OSM = OVER STROKE ACTIVE SAFETY + OVER STROKE MARKER

Il nuovo codice sarà fornito solo ad esaurimento del vecchio

The new code will be supplied only when the old will be out of stock

Der neue Kode wird nur angegeben, wenn der alte nicht mehr lieferbar ist

Le nouveau code sera fourni uniquement lorsque le vieux stock sera écoulé

El nuevo código será suministrado sólo cuando se agoten las existencias del antiguo

O novo código irá ser fornecido apenas quando o antigo esgotar stock



* $F_{1i} =$

Isothermal end force at 100% Cu p. 16

** $F_{1p} =$

Polytrophic end force at 100% Cu

RG

N ₂		0 - 80 °C 32 - 176 °F	ΔP $\pm 0,33 \% / ^\circ C$	P max 150 bar 2175 psi	P min 20 bar 290 psi	S 6,15 cm ² 0.953 in ²	SPM ~ 20 - 100 (at 20°C)	Max Speed 1,8 m/s 70.8 in/s	Maintenance kit 39BMRV01000C	
CODE		Cu	L	L min	F0	F _{1i} *	F _{1p} **	V0		PED 2014/68/EU
PHASING OUT from 04/2021	NEW	mm inch	mm inch	mm inch	Initial force daN lb	End force * daN lb	End force ** daN lb	cm ³ in ³	~Kg ~lb	2014/68/EU
RG 1000 - 010 - A	◆ RG 1000 - 010 - B	10 0.39	72 2.83	62 2.44	920 2068 $\pm 5\%$	1281 2881	1493 3357	25,6 1.56	0,67 1.48	✓
RG 1000 - 013 - A	◆ RG 1000 - 013 - B	13 0.51	78 3.07	65 2.56		1331 2992	1570 3531	30,3 1.85	0,70 1.54	✓
RG 1000 - 016 - A	RG 1000 - 016 - B	16 0.63	84 3.31	68 2.68		1370 3079	1631 3667	35,0 2.14	0,72 1.59	✓
RG 1000 - 019 - A	RG 1000 - 019 - B	19 0.75	90 3.54	71 2.80		1401 3149	1680 3778	39,6 2.42	0,75 1.65	✓
RG 1000 - 025 - A	RG 1000 - 025 - B	25 0.98	102 4.02	77 3.03		1447 3253	1755 3945	49,0 2.99	0,79 1.74	✓
RG 1000 - 032 - A	RG 1000 - 032 - B	32 1.26	116 4.57	84 3.31		1485 3339	1816 4083	59,9 3.66	0,85 1.87	✓
RG 1000 - 038 - A	RG 1000 - 038 - B	38 1.50	128 5.04	90 3.54		1509 3392	1855 4170	69,2 4.22	0,90 1.98	✓
RG 1000 - 050 - A	RG 1000 - 050 - B	50 1.97	152 5.98	102 4.02		1543 3468	1910 4294	87,9 5.36	0,99 2.18	✓
RG 1000 - 063 - A	RG 1000 - 063 - B	63 2.48	178 7.01	115 4.53		1567 3522	1950 4384	108,2 6.60	1,10 2.43	✓
RG 1000 - 075 - A	RG 1000 - 075 - B	75 2.95	202 7.95	127 5.00		1583 3558	1976 4442	126,9 7.74	1,19 2.62	✓
RG 1000 - 080 - A	RG 1000 - 080 - B	80 3.15	212 8.35	132 5.20	1588 3570	1985 4462	134,7 8.22	1,23 2.71	✓	
RG 1000 - 100 - A	RG 1000 - 100 - B	100 3.94	252 9.92	152 5.98	1605 3607	2013 4524	165,8 10.12	1,39 3.06	✓	
RG 1000 - 125 - A	RG 1000 - 125 - B	125 4.92	302 11.89	177 6.97	1618 3638	2036 4577	204,8 12.50	1,60 3.53	✓	

◆ Disposable

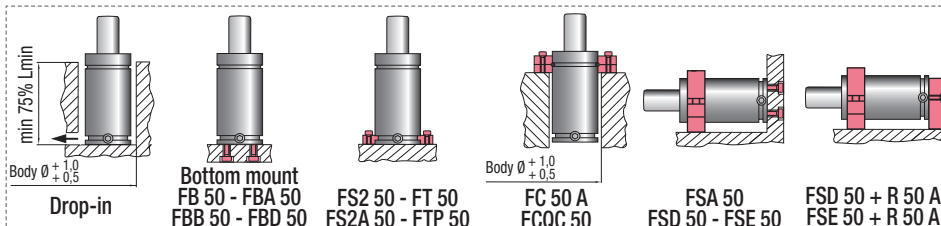

HOW TO ORDER

p. 95

INSTALLATION GUIDELINE

p. 205



OSAS + OSM = **OVER STROKE ACTIVE SAFETY** + **OVER STROKE MARKER**

ACTIVE SAFETY



OSAS



USAS



OPAS

Il nuovo codice sarà fornito solo ad esaurimento del vecchio

The new code will be supplied only when the old will be out of stock

Der neue Kode wird nur angegeben, wenn der alte nicht mehr lieferbar ist

Le nouveau code sera fourni uniquement lorsque le vieux stock sera épuisé

El nuevo código será suministrado sólo cuando se agoten las existencias del antiguo

O novo código irá ser fornecido apenas quando o antigo esgotar stock



* F_{1i} =

Isothermal end force at 100% Cu

p. 16

** F_{1p} =

Polytropic end force at 100% Cu

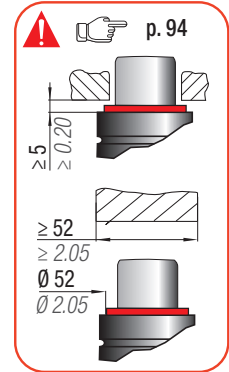
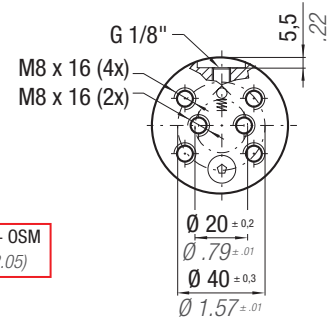
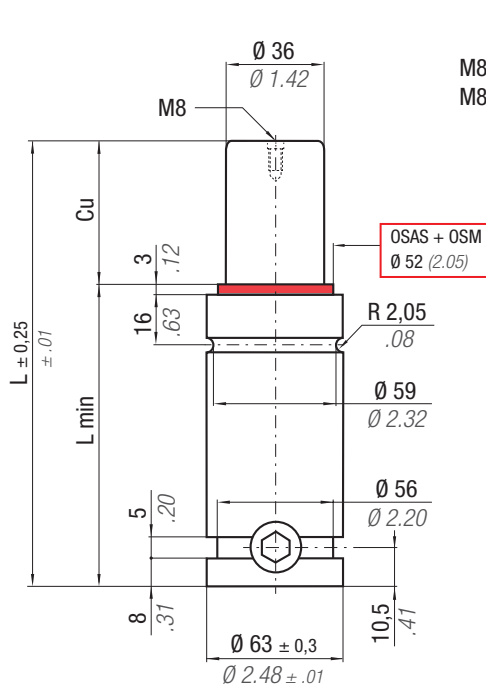

N₂		0 - 80 °C 32 - 176 °F	ΔP ± 0,33 %/°C	P max 150 bar 2175 psi	P min 20 bar 290 psi	S 10,18 cm ² 1,578 in ²	SPM ~ 20 - 100 (at 20°C)	Max Speed 1,8 m/s 70,8 in/s	Maintenance kit 39BMRV01500C	
CODE	NEW	Cu	L	L min	F₀	F_{1i} *	F_{1p} **	V₀		PED 2014/68/EU
PHASING OUT from 04/2021		mm inch	mm inch	mm inch	Initial force daN lb	End force * daN lb	End force ** daN lb	cm ³ in ³	~Kg ~lb	✓
RG 1500 - 010 - A	◆ RG 1500 - 010 - B	10 0.39	72 2.83	62 2.44	1530 3440 ± 5% 150 bar 2175 psi + 20 °C +68 °F	2078 4671	2406 5409	45 2.72	1,04 2.29	✓
RG 1500 - 013 - A	◆ RG 1500 - 013 - B	13 0.51	78 3.07	65 2.56		2157 4848	2528 5683	53 3.20	1,08 2.38	✓
RG 1500 - 016 - A	◆ RG 1500 - 016 - B	16 0.63	84 3.31	68 2.68		2218 4987	2624 5900	61 3.69	1,11 2.45	✓
RG 1500 - 019 - A	RG 1500 - 019 - B	19 0.75	90 3.54	71 2.80		2268 5099	2703 6076	68 4.17	1,15 2.54	✓
RG 1500 - 025 - A	RG 1500 - 025 - B	25 0.98	102 4.02	77 3.03		2343 5267	2822 6344	84 5.14	1,22 2.69	✓
RG 1500 - 032 - A	RG 1500 - 032 - B	32 1.26	116 4.57	84 3.31		2405 5406	2921 6566	103 6.27	1,30 2.87	✓
RG 1500 - 038 - A	RG 1500 - 038 - B	38 1.50	128 5.04	90 3.54		2444 5493	2984 6708	119 7.23	1,37 3.02	✓
RG 1500 - 050 - A	RG 1500 - 050 - B	50 1.97	152 5.98	102 4.02		2499 5617	3073 6909	150 9.17	1,51 3.33	✓
RG 1500 - 063 - A	RG 1500 - 063 - B	63 2.48	178 7.01	115 4.53		2538 5707	3139 7056	185 11.26	1,67 3.68	✓
RG 1500 - 075 - A	RG 1500 - 075 - B	75 2.95	202 7.95	127 5.00		2565 5765	3182 7152	216 13.19	1,81 3.99	✓
RG 1500 - 080 - A	RG 1500 - 080 - B	80 3.15	212 8.35	132 5.20	2573 5785	3196 7185	229 13.99	1,87 4.12	✓	
RG 1500 - 100 - A	RG 1500 - 100 - B	100 3.94	252 9.92	152 5.98	2601 5847	3242 7287	282 17.21	2,11 4.65	✓	
RG 1500 - 125 - A	RG 1500 - 125 - B	125 4.92	302 11.89	177 6.97	2624 5899	3280 7373	348 21.24	2,40 5.29	✓	

◆ Disposable

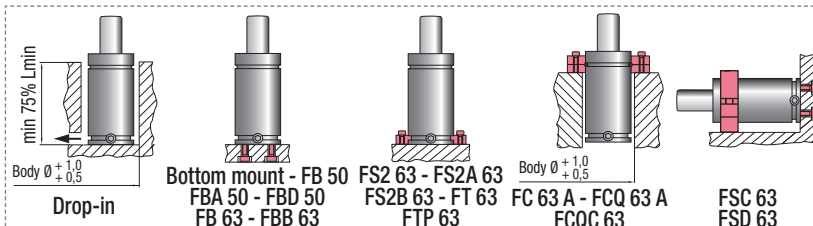

HOW TO ORDER
 p. 95

INSTALLATION GUIDELINE
 p. 205

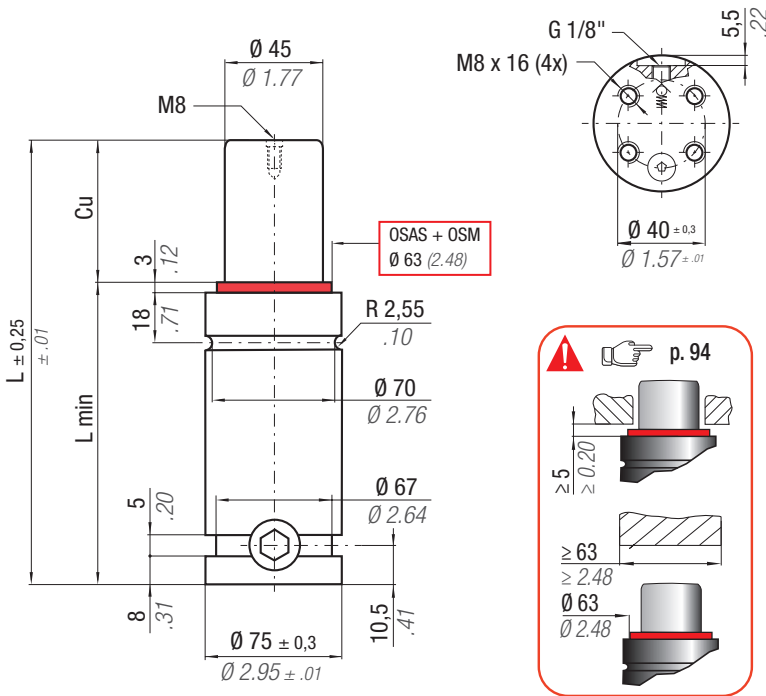

OSAS + OSM = OVER STROKE ACTIVE SAFETY + OVER STROKE MARKER



Il nuovo codice sarà fornito solo ad esaurimento del vecchio
 The new code will be supplied only when the old will be out of stock
 Der neue Kode wird nur angegeben, wenn der alte nicht mehr lieferbar ist
 Le nouveau code sera fourni uniquement lorsque le vieux stock sera épuisé
 El nuevo código será suministrado sólo cuando se agoten las existencias del antiguo
 O novo código irá ser fornecido apenas quando o antigo esgotar stock

ACTIVE SAFETY



OSAS



USAS



OPAS

easu MANIFOLD p. 247

p. 262

* F_{1i} = Isothermal end force at 100% Cu p. 16

** F_{1p} = Polytrophic end force at 100% Cu

RG

	0 - 80 °C 32 - 176 °F	ΔP ± 0,33 %/°C	P max 150 bar 2175 psi	P min 20 bar 290 psi	S 15,90 cm ² 2.465 in ²	SPM ~ 20 - 100 (at 20°C)	Max Speed 1,8 m/s 70.8 in/s	Maintenance kit 39BMRV02400D
--	--------------------------	---------------------------	-------------------------------------	-----------------------------------	------------------------------------------------------------	---------------------------------------	------------------------------------------	----------------------------------------

CODE PHASING OUT from 04/2021	NEW	Cu		L		L min		F0 Initial force		F _{1i} * End force *		F _{1p} ** End force **		V0		PED 2014/68/EU		
		mm	inch	mm	inch	mm	inch	daN	lb	daN	lb	daN	lb	cm ³	in ³	~Kg	~lb	✓
RG 2400 - 010 - A	◆ RG 2400 - 010 - B	10	0.39	79	3.11	69	2.72	2385 ± 5% 5362	150 bar 2175 psi	3148	7078	3609	8113	77	4.67	1,65	3.64	✓
RG 2400 - 013 - A	◆ RG 2400 - 013 - B	13	0.51	85	3.35	72	2.83			3274	7361	3802	8547	89	5.40	1,70	3.75	✓
RG 2400 - 016 - A	◆ RG 2400 - 016 - B	16	0.63	91	3.58	75	2.95			3376	7590	3960	8903	101	6.13	1,75	3.86	✓
RG 2400 - 019 - A	◆ RG 2400 - 019 - B	19	0.75	97	3.82	78	3.07			3461	7781	4092	9200	113	6.87	1,79	3.95	✓
RG 2400 - 025 - A	RG 2400 - 025 - B	25	0.98	109	4.29	84	3.31			3593	8077	4301	9668	137	8.34	1,89	4.17	✓
RG 2400 - 032 - A	RG 2400 - 032 - B	32	1.26	123	4.84	91	3.58			3705	8329	4479	10070	165	10.04	1,99	4.39	✓
RG 2400 - 038 - A	RG 2400 - 038 - B	38	1.50	135	5.31	97	3.82			3778	8492	4597	10333	189	11.51	2,09	4.61	✓
RG 2400 - 050 - A	RG 2400 - 050 - B	50	1.97	159	6.26	109	4.29			3883	8730	4768	10719	237	14.44	2,28	5.03	✓
RG 2400 - 063 - A	RG 2400 - 063 - B	63	2.48	185	7.28	122	4.80			3961	8905	4896	11006	289	17.62	2,49	5.49	✓
RG 2400 - 075 - A	RG 2400 - 075 - B	75	2.95	209	8.23	134	5.28			4014	9023	4982	11199	337	20.55	2,68	5.91	✓
RG 2400 - 080 - A	RG 2400 - 080 - B	80	3.15	219	8.62	139	5.47	4031	9063	5011	11266	357	21.78	2,75	6.06	✓		
RG 2400 - 100 - A	RG 2400 - 100 - B	100	3.94	259	10.20	159	6.26	4088	9189	5104	11474	437	26.67	3,07	6.77	✓		
RG 2400 - 125 - A	RG 2400 - 125 - B	125	4.92	309	12.17	184	7.24	4134	9293	5180	11646	537	32.79	3,46	7.63	✓		

◆ Disposable

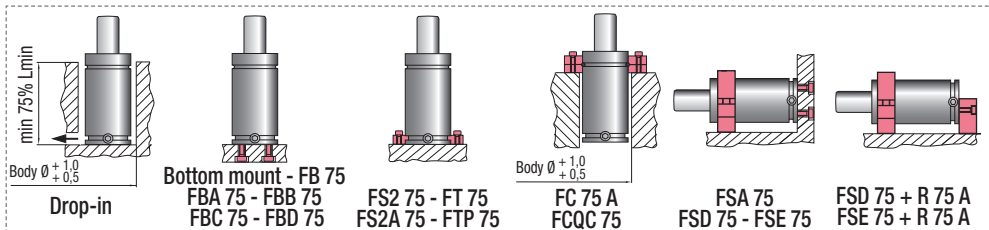

HOW TO ORDER

p. 95

INSTALLATION GUIDELINE

p. 205



OSAS + OSM = OVER STROKE ACTIVE SAFETY + OVER STROKE MARKER

ACTIVE SAFETY



OSAS



USAS



OPAS

Il nuovo codice sarà fornito solo ad esaurimento del vecchio
 The new code will be supplied only when the old will be out of stock
 Der neue Kode wird nur angegeben, wenn der alte nicht mehr lieferbar ist
 Le nouveau code sera fourni uniquement lorsque le vieux stock sera écoulé
 El nuevo código será suministrado sólo cuando se agoten las existencias del antiguo
 O novo código irá ser fornecido apenas quando o antigo esgotar stock

easU MANIFOLD p. 247

p. 262

* F_{1i} = Isothermal end force at 100% Cu p. 16

** F_{1p} = Polytropic end force at 100% Cu

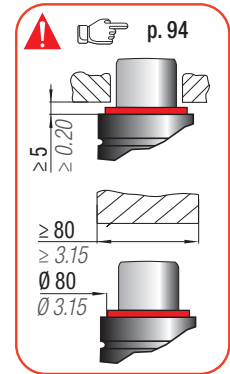
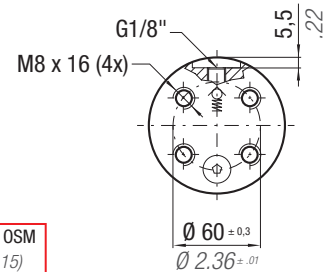
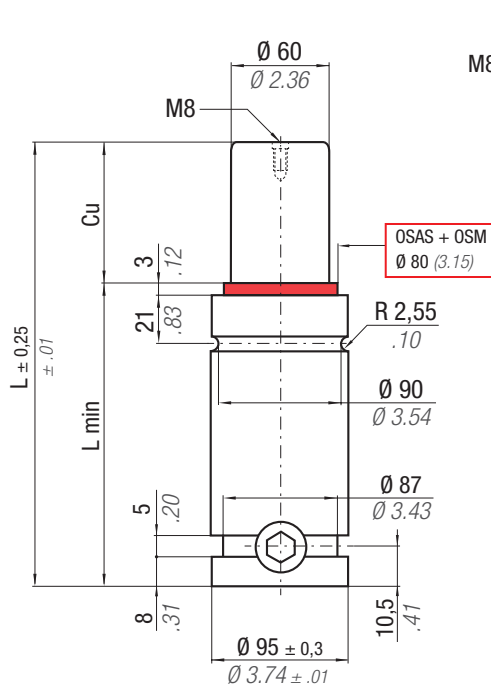

N₂	0 - 80 °C 32 - 176 °F	ΔP ± 0,33 %/°C	P max 150 bar 2175 psi	P min 20 bar 290 psi	S 28,27 cm ² 4.382 in ²	SPM ~ 20 - 100 (at 20°C)	Max Speed 1,8 m/s 70.8 in/s	Maintenance kit 39BMRV04200C
----------------------	--------------------------	---------------------------	-------------------------------------	-----------------------------------	------------------------------------------------------------	---------------------------------------	------------------------------------------	----------------------------------------

CODE PHASING OUT from 04/2021	NEW	Cu		L		L min		F ₀		F _{1i} *		F _{1p} **		V ₀		PED 2014/68/EU		
		mm	inch	mm	inch	mm	inch	daN	lb	daN	lb	daN	lb	cm ³	in ³		~Kg	~lb
RG 4200 - 016 - A	◆ RG 4200 - 016 - B	16	0.63	94	3.70	78	3.07	4240 ± 5% 150 bar 2175 psi + 20 °C +68 °F	9532	6103	13720	7197	16179	172	10.48	2,98	6.57	✓
RG 4200 - 019 - A	◆ RG 4200 - 019 - B	19	0.75	100	3.94	81	3.19			6269	14093	7458	16767	192	11.71	3,05	6.72	✓
RG 4200 - 025 - A	RG 4200 - 025 - B	25	0.98	112	4.41	87	3.43			6531	14682	7874	17702	232	14.18	3,20	7.05	✓
RG 4200 - 032 - A	RG 4200 - 032 - B	32	1.26	126	4.96	94	3.70			6755	15186	8236	18515	280	17.06	3,38	7.45	✓
RG 4200 - 038 - A	RG 4200 - 038 - B	38	1.50	138	5.43	100	3.94			6902	15517	8475	19052	320	19.52	3,52	7.76	✓
RG 4200 - 050 - A	RG 4200 - 050 - B	50	1.97	162	6.38	112	4.41			7117	16001	8827	19844	401	24.45	3,82	8.42	✓
RG 4200 - 063 - A	RG 4200 - 063 - B	63	2.48	188	7.40	125	4.92			7278	16361	9092	20440	488	29.80	4,15	9.15	✓
RG 4200 - 075 - A	RG 4200 - 075 - B	75	2.95	212	8.35	137	5.39			7386	16604	9272	20843	569	34.73	4,45	9.81	✓
RG 4200 - 080 - A	RG 4200 - 080 - B	80	3.15	222	8.74	142	5.59			7423	16687	9333	20982	603	36.79	4,57	10.08	✓
RG 4200 - 100 - A	RG 4200 - 100 - B	100	3.94	262	10.31	162	6.38			7539	16949	9529	21421	738	45.01	5,07	11.18	✓
RG 4200 - 125 - A	RG 4200 - 125 - B	125	4.92	312	12.28	187	7.36	7639	17173	9696	21798	906	55.29	5,69	12.54	✓		

◆ Disposable

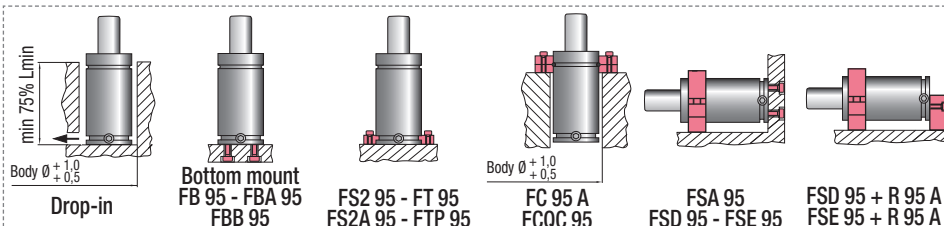

HOW TO ORDER p. 95

INSTALLATION GUIDELINE p. 205

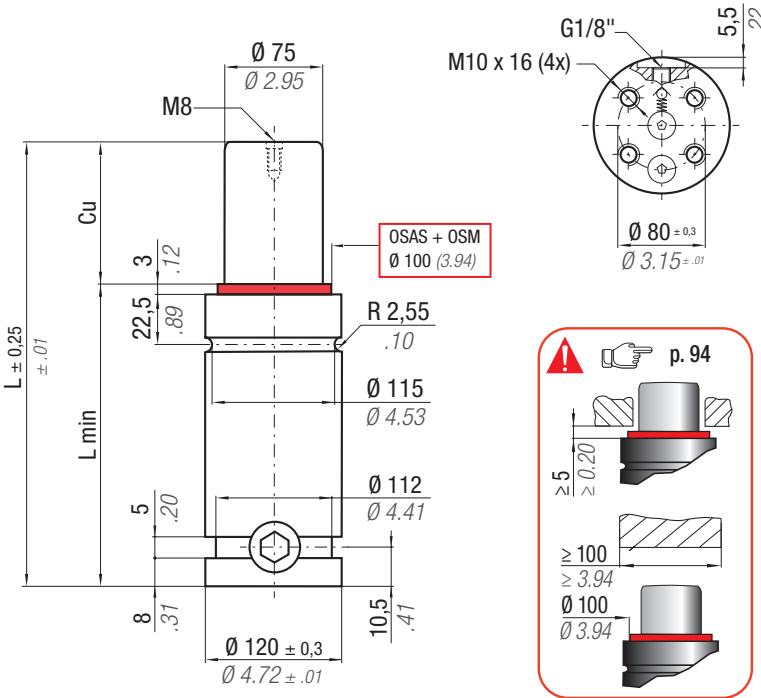

OSAS + OSM = OVER STROKE ACTIVE SAFETY + OVER STROKE MARKER



Il nuovo codice sarà fornito solo ad esaurimento del vecchio

The new code will be supplied only when the old will be out of stock

Der neue Kode wird nur angegeben, wenn der alte nicht mehr lieferbar ist

Le nouveau code sera fourni uniquement lorsque le vieux stock sera écoulé

El nuevo código será suministrado sólo cuando se agoten las existencias del antiguo

O novo código irá ser fornecido apenas quando o antigo esgotar stock

ACTIVE SAFETY



OSAS



USAS



OPAS

easu MANIFOLD p. 247

p. 262

* $F_{1i} =$

Isothermal end force at 100% Cu

p. 16

** $F_{1p} =$

Polytrophic end force at 100% Cu

RG

N ₂		0 - 80 °C 32 - 176 °F	ΔP ± 0,33 %/°C	P max 150 bar 2175 psi	P min 20 bar 290 psi	S 44,18 cm ² 6.848 in ²	SPM ~ 20 - 100 (at 20°C)	Max Speed 1,8 m/s 70.8 in/s	Maintenance kit 39BMRV06600C
CODE	NEW	Cu	L	L min	F ₀	F _{1i} *	F _{1p} **	V ₀	
PHASING OUT from 04/2021		mm inch	mm inch	mm inch	Initial force daN lb	End force * daN lb	End force ** daN lb	cm ³ in ³	~Kg ~lb
RG 6600 - 016 - A	◆ RG 6600 - 016 - B	16 0.63	104 4.09	88 3.46	6630 14904 ± 5%	9056 20359	10500 23606	306 18.69	5,40 11.90
RG 6600 - 019 - A	◆ RG 6600 - 019 - B	19 0.75	110 4.33	91 3.58		9306 20920	10887 24474	338 20.64	5,52 12.17
RG 6600 - 025 - A	RG 6600 - 025 - B	25 0.98	122 4.80	97 3.82		9712 21832	11521 25901	402 24.54	5,76 12.70
RG 6600 - 032 - A	RG 6600 - 032 - B	32 1.26	136 5.35	104 4.09		10073 22644	12093 27187	477 29.08	6,04 13.32
RG 6600 - 038 - A	RG 6600 - 038 - B	38 1.50	148 5.83	110 4.33		10316 23192	12483 28063	541 32.98	6,28 13.85
RG 6600 - 050 - A	RG 6600 - 050 - B	50 1.97	172 6.77	122 4.80		10683 24016	13075 29394	668 40.78	6,76 14.90
RG 6600 - 063 - A	RG 6600 - 063 - B	63 2.48	198 7.80	135 5.31		10964 24648	13534 30427	807 49.23	7,28 16.05
RG 6600 - 075 - A	RG 6600 - 075 - B	75 2.95	222 8.74	147 5.79		11157 25083	13852 31141	935 57.03	7,75 17.09
RG 6600 - 080 - A	RG 6600 - 080 - B	80 3.15	232 9.13	152 5.98		11225 25234	13963 31390	988 60.28	7,95 17.53
RG 6600 - 100 - A	RG 6600 - 100 - B	100 3.94	272 10.71	172 6.77		11439 25715	14318 32188	1201 73.28	8,75 19.29
RG 6600 - 125 - A	RG 6600 - 125 - B	125 4.92	322 12.68	197 7.76	11625 26133	14628 32885	1467 89.53	9,75 21.50	

◆ Disposable

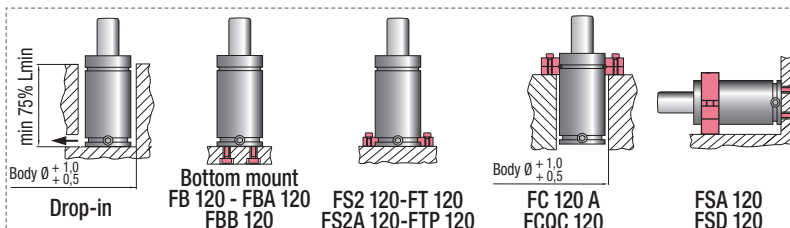

HOW TO ORDER

p. 95

INSTALLATION GUIDELINE

p. 205

Mazda	Nissan	PSA
Renault	Toyota	

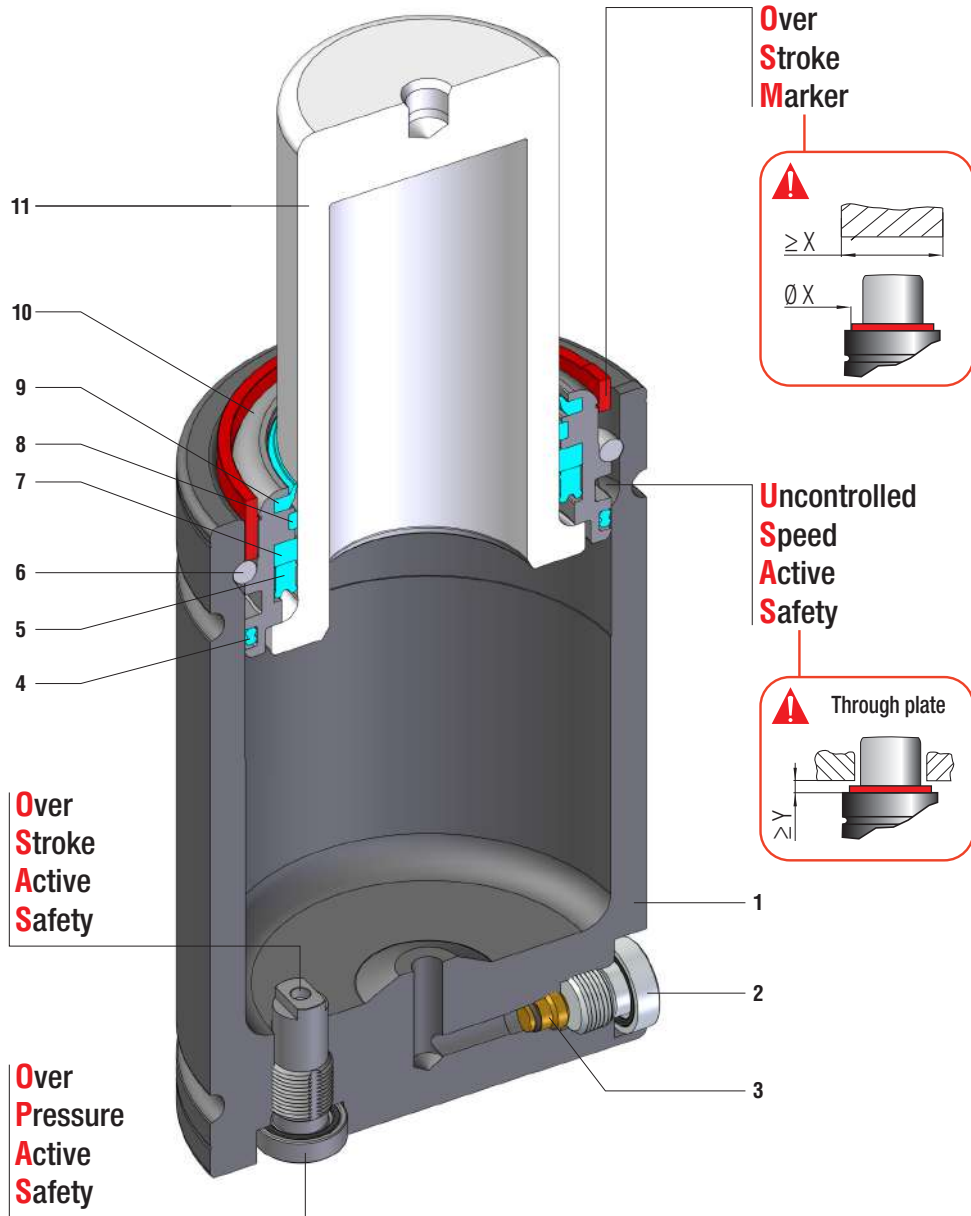

Minima altezza, massima forza, collegabili G1/8 - Minimum height, maximum force, hose cylinders with G1/8 charging port
 Minimale Höhe, maximale Kraft, Gdf. mit G1/8 Öffnung verbindbar - Hauteur minimale, force maximale, cylindres raccordés avec trou G1/8 gaz
 Mínima altura, máxima fuerza, cilindros conectados con agujero G1/8 gas - Altura mínima, força máxima, cilindros conectados com furo G1/8 gás

SEALING	ROD SEAL
DESIGN	BUSH - BODY DESIGN

1	Body	5	Rod seal	9	Rod wiper
2	Plug	6	Retaining ring	10	Bush
3	Valve	7	Back-up ring	11	Rod (nitrited superfinished)
4	Dual ring seal	8	Guide ring		

RANGE CHART

Model	Body Ø		Stroke Cu		Initial force F0						
	mm	inch	mm	inch	daN	lb	OSAS	USAS	OPAS	SKUDO	SW
RT 350	32	1.26	10 - 125	0.39 - 4.92	360	809	✓	✓	✓	-	✓
RT 500	38	1.50	10 - 125	0.39 - 4.92	470	1057	✓	✓	✓	-	✓
RT 750	45	1.77	10 - 125	0.39 - 4.92	740	1664	✓	✓	✓	-	✓
RT 1000	50	1.97	10 - 125	0.39 - 4.92	920	2068	✓	✓	✓	-	✓
RT 1200	50	1.97	10 - 125	0.39 - 4.92	1047	2354	✓	✓	✓	-	✓
RT 1500	63	2.48	10 - 125	0.39 - 4.92	1530	3440	✓	✓	✓	-	✓
RT 2400	75	2.95	10 - 125	0.39 - 4.92	2385	5362	✓	✓	✓	-	✓
RT 4200	95	3.74	16 - 125	0.63 - 4.92	4240	9532	✓	✓	✓	-	✓
RT 6600	120	4.72	16 - 125	0.63 - 4.92	6630	14905	✓	✓	✓	-	✓
RT 9500	150	5.91	19 - 125	0.75 - 4.92	9540	21447	✓	✓	✓	-	✓

Built-in as standard
 Optional upon request

RT

HOW TO ORDER



Available versions

RT 2400-050-B Standard code	RT 2400-050-B-W Add "-W" to standard code	RT 2400-050-B-N Add "-N" to standard code	RT 2400-050-B-N-W Add "-N-W" to standard code	RT 2400-050-B-E Add "-E" to standard code	RT 2400-050-B-E-W Add "-E-W" to standard code
Self contained	Self contained + Secondary wiper	Linkable	Linkable + Secondary wiper	Easy Manifold	Easy Manifold + Secondary wiper



OSAS + OSM = OVER STROKE ACTIVE SAFETY + OVER STROKE MARKER

ACTIVE SAFETY



OSAS



USAS



OPAS

Il nuovo codice sarà fornito solo ad esaurimento del vecchio

The new code will be supplied only when the old will be out of stock

Der neue Kode wird nur angegeben, wenn der alte nicht mehr lieferbar ist

Le nouveau code sera fourni uniquement lorsque le vieux stock sera écoulé

El nuevo código será suministrado sólo cuando se agoten las existencias del antiguo

O novo código irá ser fornecido apenas quando o antigo esgotar stock



* F_{1i} =

Isothermal end force at 100% Cu



p. 16

** F_{1p} =

Polytrophic end force at 100% Cu

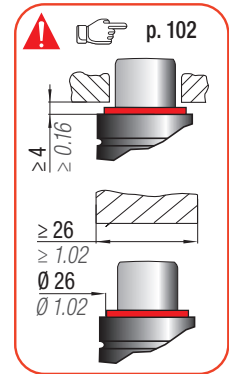
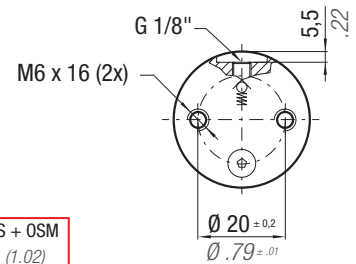
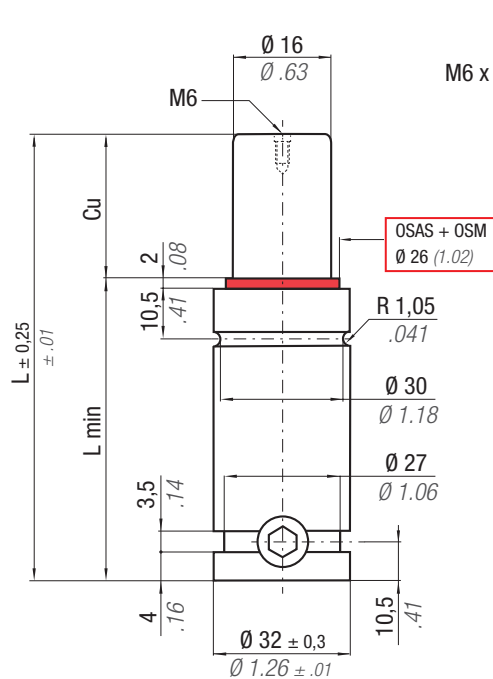

N ₂	0 - 80 °C 32 - 176 °F	ΔP ± 0,33 %/°C	P max 180 bar 2610 psi	P min 20 bar 290 psi	S 2,01 cm ² 0,312 in ²	SPM ~ 20 - 100 (at 20°C)	Max Speed 1,8 m/s 70,8 in/s	Maintenance kit 39BMRV00350C
----------------	--------------------------	---------------------------	------------------------------	----------------------------	----------------------------------------------------	--------------------------------	-----------------------------------	---------------------------------

CODE PHASING OUT from 04/2021	NEW	Cu		L		L min		F ₀		F _{1i} *		F _{1p} **		V ₀		~Kg	~lb	PED 2014/68/EU
		mm	inch	mm	inch	mm	inch	daN	lb	daN	lb	daN	lb	cm ³	in ³			
RT 350 - 010 - A	♦ RT 350 - 010 - B	10	0.39	60	2.36	50	1.97	360 ± 5%	809	531	1194	607	1366	7,7	0,47	0,22	0,48	✓
RT 350 - 013 - A	♦ RT 350 - 013 - B	13	0.51	66	2.60	53	2.09			544	1224	627	1409	9,5	0,58	0,23	0,50	✓
RT 350 - 016 - A	RT 350 - 016 - B	16	0.63	72	2.83	56	2.20			554	1245	641	1440	11,2	0,68	0,24	0,52	✓
RT 350 - 019 - A	RT 350 - 019 - B	19	0.75	78	3.07	59	2.32			561	1261	651	1463	13,0	0,79	0,25	0,54	✓
RT 350 - 025 - A	RT 350 - 025 - B	25	0.98	90	3.54	65	2.56			571	1283	665	1496	16,6	1,01	0,27	0,60	✓
RT 350 - 032 - A	RT 350 - 032 - B	32	1.26	104	4.09	72	2.83			578	1300	676	1520	20,7	1,26	0,29	0,64	✓
RT 350 - 038 - A	RT 350 - 038 - B	38	1.50	116	4.57	78	3.07			583	1310	683	1535	24,3	1,48	0,31	0,68	✓
RT 350 - 050 - A	RT 350 - 050 - B	50	1.97	140	5.51	90	3.54			589	1323	691	1554	31,4	1,92	0,35	0,77	✓
RT 350 - 063 - A	RT 350 - 063 - B	63	2.48	166	6.54	103	4.06			593	1333	697	1568	39,1	2,39	0,39	0,86	✓
RT 350 - 075 - A	RT 350 - 075 - B	75	2.95	190	7.48	115	4.53			595	1338	701	1576	46,3	2,83	0,43	0,95	✓
RT 350 - 080 - A	RT 350 - 080 - B	80	3.15	200	7.87	120	4.72	596	1340	702	1579	49,2	3,00	0,45	0,99	✓		
RT 350 - 100 - A	RT 350 - 100 - B	100	3.94	240	9.45	140	5.51	599	1346	706	1588	61,1	3,73	0,51	1,12	✓		
RT 350 - 125 - A	RT 350 - 125 - B	125	4.92	290	11.42	165	6.50	606	1363	717	1613	74,9	4,57	0,59	1,30	✓		

♦ Disposable

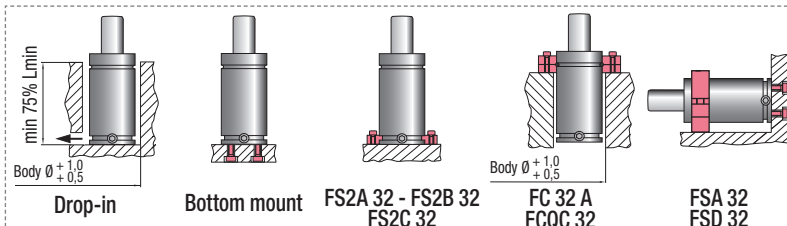

HOW TO ORDER
 p. 103

INSTALLATION GUIDELINE
 p. 205



ACTIVE SAFETY



OSAS



USAS



OPAS

OSAS + OSM = OVER STROKE ACTIVE SAFETY + OVER STROKE MARKER

Il nuovo codice sarà fornito solo ad esaurimento del vecchio

The new code will be supplied only when the old will be out of stock

Der neue Kode wird nur angegeben, wenn der alte nicht mehr lieferbar ist

Le nouveau code sera fourni uniquement lorsque le vieux stock sera écoulé

El nuevo código será suministrado sólo cuando se agoten las existencias del antiguo

O novo código irá ser fornecido apenas quando o antigo esgotar stock



* $F_{1i} =$

Isothermal end force at 100% Cu

p. 16

** $F_{1p} =$

Polytrophic end force at 100% Cu

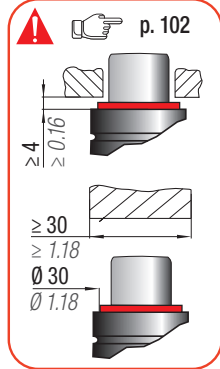
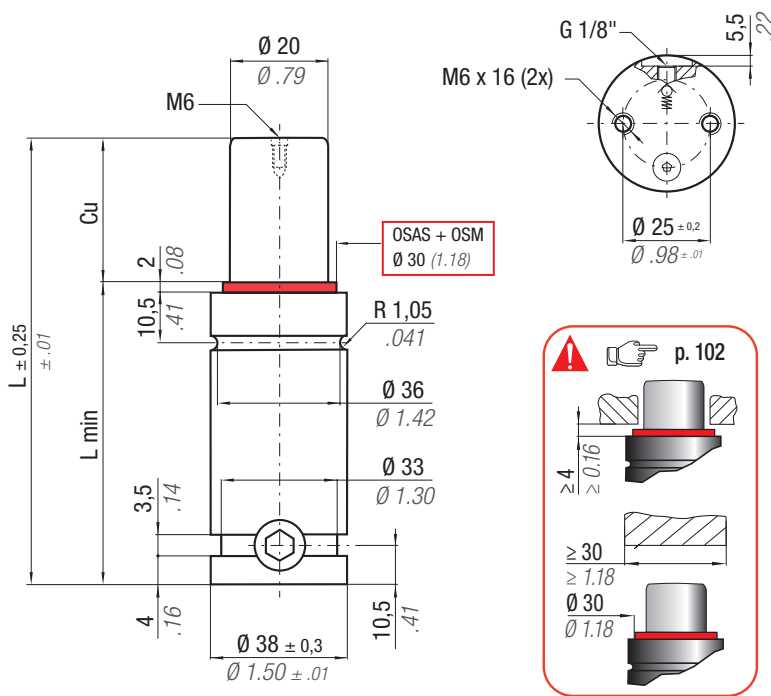

N ₂		0 - 80 °C 32 - 176 °F	ΔP ± 0,33 %/°C	P max 150 bar 2175 psi	P min 20 bar 290 psi	S 3,14 cm ² 0.487 in ²	SPM ~ 20 - 100 (at 20°C)	Max Speed 1,8 m/s 70.8 in/s	Maintenance kit 39BMRV00500C	
CODE PHASING OUT from 04/2021	NEW	Cu	L	L min	F ₀	F _{1i} *	F _{1p} **	V ₀		
RT 500 - 010 - A	♦ RT 500 - 010 - B	10 0.39	60 2.36	50 1.97	470 1057 ± 5%	696 1565	828 1862	11,2 0.68	0,32 0.71	
RT 500 - 013 - A	♦ RT 500 - 013 - B	13 0.51	66 2.60	53 2.09		716 1609	859 1931	13,8 0.84	0,34 0.75	
RT 500 - 016 - A	RT 500 - 016 - B	16 0.63	72 2.83	56 2.20		730 1641	882 1982	16,3 0.99	0,36 0.79	
RT 500 - 019 - A	RT 500 - 019 - B	19 0.75	78 3.07	59 2.32		740 1664	899 2020	18,9 1.15	0,37 0.82	
RT 500 - 025 - A	RT 500 - 025 - B	25 0.98	90 3.54	65 2.56		755 1698	922 2074	24,0 1.46	0,40 0.88	
RT 500 - 032 - A	RT 500 - 032 - B	32 1.26	104 4.09	72 2.83		766 1723	941 2115	30,0 1.83	0,43 0.95	
RT 500 - 038 - A	RT 500 - 038 - B	38 1.50	116 4.57	78 3.07		150 bar 2175psi	773 1738	952 2140	35,1 2.14	0,46 1.01
RT 500 - 050 - A	RT 500 - 050 - B	50 1.97	140 5.51	90 3.54		782 1759	967 2173	45,3 2.76	0,52 1.15	
RT 500 - 063 - A	RT 500 - 063 - B	63 2.48	166 6.54	103 4.06		+ 20 °C +68 °F	789 1773	977 2196	56,4 3.44	0,58 1.28
RT 500 - 075 - A	RT 500 - 075 - B	75 2.95	190 7.48	115 4.53		792 1782	984 2211	66,6 4.06	0,63 1.39	
RT 500 - 080 - A	RT 500 - 080 - B	80 3.15	200 7.87	120 4.72	794 1785	986 2216	70,8 4.32	0,66 1.46		
RT 500 - 100 - A	RT 500 - 100 - B	100 3.94	240 9.45	140 5.51	798 1794	992 2231	87,9 5.36	0,75 1.65		
RT 500 - 125 - A	RT 500 - 125 - B	125 4.92	290 11.42	165 6.50	801 1801	998 2243	109,2 6.66	0,87 1.92		

♦ Disposable

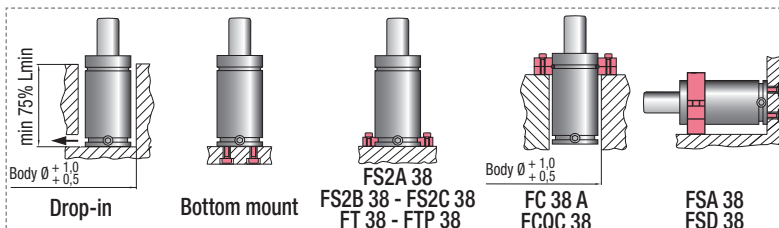

HOW TO ORDER

p. 103

INSTALLATION GUIDELINE

p. 205

RT 750

PG24D (Mazda)

K 32 R (Nissan)

EM24.54.700 (Renault)



OSAS + OSM = OVER STROKE ACTIVE SAFETY + OVER STROKE MARKER

ACTIVE SAFETY



OSAS



USAS



OPAS

Il nuovo codice sarà fornito solo ad esaurimento del vecchio

The new code will be supplied only when the old will be out of stock

Der neue Kode wird nur angegeben, wenn der alte nicht mehr lieferbar ist

Le nouveau code sera fourni uniquement lorsque le vieux stock sera épuisé

El nuevo código será suministrado sólo cuando se agoten las existencias del antiguo

O novo código irá ser fornecido apenas quando o antigo esgotar stock



* F_{1i} =

Isothermal end force at 100% Cu



p. 16

** F_{1p} =

Polytropic end force at 100% Cu

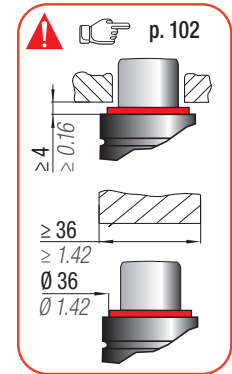
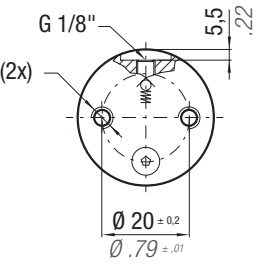
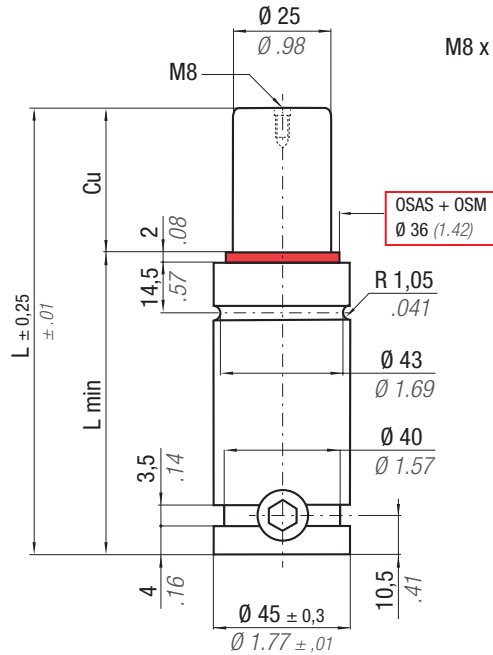

N ₂	0 - 80 °C 32 - 176 °F	ΔP ± 0,33 %/°C	P max 150 bar 2175 psi	P min 20 bar 290 psi	S 4,91 cm ² 0,761 in ²	SPM ~ 20 - 100 (at 20°C)	Max Speed 1,8 m/s 70,8 in/s	Maintenance kit 39BMRV00750C
----------------	--------------------------	---------------------------	------------------------------	----------------------------	----------------------------------------------------	--------------------------------	-----------------------------------	---------------------------------

CODE PHASING OUT from 04/2021	NEW	Cu		L		L min		F ₀		F _{1i} *		F _{1p} **		V ₀		~Kg	~lb	PED 2014/68/EU
		mm	inch	mm	inch	mm	inch	daN	lb	daN	lb	daN	lb	cm ³	in ³			
RT 750 - 010 - A	♦ RT 750 - 010 - B	10	0.39	67	2.64	57	2.24	740 ± 5%	1664	1026	2307	1198	2693	20,2	1.23	0,50	1.10	✓
RT 750 - 013 - A	♦ RT 750 - 013 - B	13	0.51	73	2.87	60	2.36			1065	2394	1258	2828	23,9	1.46	0,52	1.15	✓
RT 750 - 016 - A	RT 750 - 016 - B	16	0.63	79	3.11	63	2.48			1095	2461	1305	2933	27,7	1.69	0,54	1.19	✓
RT 750 - 019 - A	RT 750 - 019 - B	19	0.75	85	3.35	66	2.60			1118	2514	1342	3017	31,5	1.92	0,56	1.23	✓
RT 750 - 025 - A	RT 750 - 025 - B	25	0.98	97	3.82	72	2.83			1153	2593	1398	3143	39,1	2.39	0,60	1.32	✓
RT 750 - 032 - A	RT 750 - 032 - B	32	1.26	111	4.37	79	3.11			1182	2656	1444	3246	47,9	2.92	0,64	1.41	✓
RT 750 - 038 - A	RT 750 - 038 - B	38	1.50	123	4.84	85	3.35			1199	2696	1473	3311	55,5	3.39	0,68	1.50	✓
RT 750 - 050 - A	RT 750 - 050 - B	50	1.97	147	5.79	97	3.82			1224	2752	1514	3403	70,6	4.31	0,76	1.68	✓
RT 750 - 063 - A	RT 750 - 063 - B	63	2.48	173	6.81	110	4.33			1242	2792	1543	3468	87,0	5.31	0,84	1.85	✓
RT 750 - 075 - A	RT 750 - 075 - B	75	2.95	197	7.76	122	4.80			1253	2818	1562	3511	102,1	6.23	0,92	2.03	✓
RT 750 - 080 - A	RT 750 - 080 - B	80	3.15	207	8.15	127	5.00			1257	2827	1568	3526	108,4	6.61	0,95	2.09	✓
RT 750 - 100 - A	RT 750 - 100 - B	100	3.94	247	9.72	147	5.79			1269	2854	1588	3571	133,7	8.16	1,08	2.38	✓
RT 750 - 125 - A	RT 750 - 125 - B	125	4.92	297	11.69	172	6.77			1280	2877	1605	3609	165,2	10.08	1,24	2.73	✓

♦ Disposable

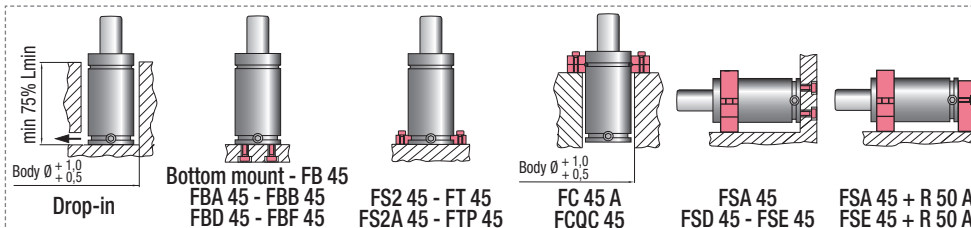

HOW TO ORDER

p. 101

INSTALLATION GUIDELINE

p. 205

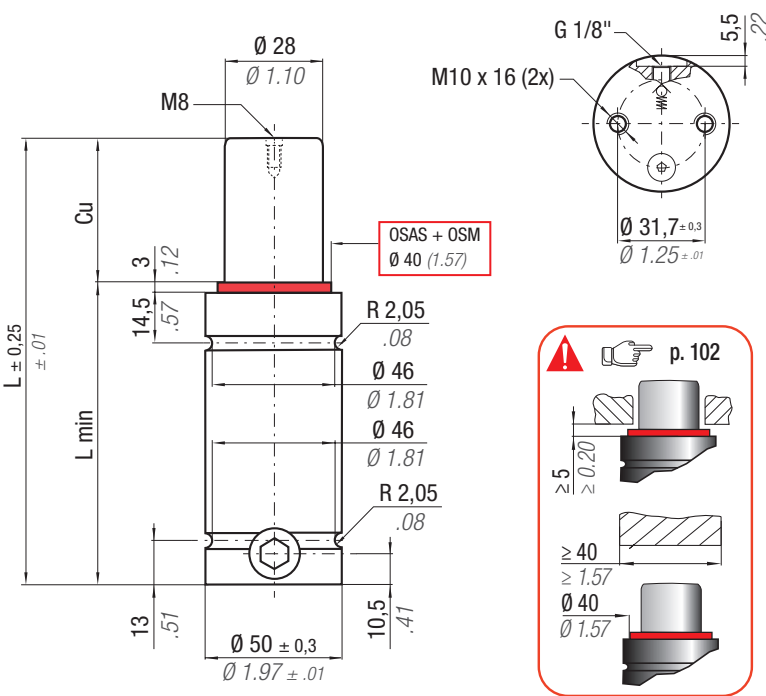

OSAS + OSM = OVER STROKE ACTIVE SAFETY + OVER STROKE MARKER



Il nuovo codice sarà fornito solo ad esaurimento del vecchio

ACTIVE SAFETY

The new code will be supplied only when the old will be out of stock



Der neue Kode wird nur angegeben, wenn der alte nicht mehr lieferbar ist

Le nouveau code sera fourni uniquement lorsque le vieux stock sera épuisé



El nuevo código será suministrado sólo cuando se agoten las existencias del antiguo

O novo código irá ser fornecido apenas quando o antigo esgotar stock



* F_{1i} = Isothermal end force at 100% Cu
 ** F_{1p} = Polytrophic end force at 100% Cu

N ₂	0 - 80 °C 32 - 176 °F	ΔP ± 0,33 %/°C	P max 150 bar 2175 psi	P min 20 bar 290 psi	S 6,15 cm ² 0.953 in ²	SPM ~ 20 - 100 (at 20°C)	Max Speed 1,8 m/s 70.8 in/s	Maintenance kit 39BMRV01000C
----------------	--------------------------	---------------------------	------------------------------	----------------------------	----------------------------------------------------	--------------------------------	-----------------------------------	---------------------------------

CODE PHASING OUT from 04/2021	NEW	Cu		L		L min		F ₀ Initial force		F _{1i} * End force *		F _{1p} ** End force **		V ₀		PED 2014/68/EU		
		mm	inch	mm	inch	mm	inch	daN	lb	daN	lb	daN	lb	cm ³	in ³	~Kg	~lb	✓
RT 1000 - 010 - A	♦ RT 1000 - 010 - B	10	0.39	72	2.83	62	2.44	920 ± 5%	2068	1282	2883	1495	3329	25,5	1,56	0,68	1,50	✓
RT 1000 - 013 - A	♦ RT 1000 - 013 - B	13	0.51	78	3.07	65	2.56			1332	2995	1572	3500	30,2	1,84	0,70	1,54	✓
RT 1000 - 016 - A	RT 1000 - 016 - B	16	0.63	84	3.31	68	2.68			1371	3082	1633	3635	34,9	2,13	0,73	1,61	✓
RT 1000 - 019 - A	RT 1000 - 019 - B	19	0.75	90	3.54	71	2.80			1402	3151	1682	3745	39,6	2,42	0,75	1,65	✓
RT 1000 - 025 - A	RT 1000 - 025 - B	25	0.98	102	4.02	77	3.03			1448	3255	1756	3909	48,9	2,98	0,80	1,76	✓
RT 1000 - 032 - A	RT 1000 - 032 - B	32	1.26	116	4.57	84	3.31			1486	3340	1817	4047	59,8	3,65	0,86	1,90	✓
RT 1000 - 038 - A	RT 1000 - 038 - B	38	1.50	128	5.04	90	3.54			1510	3394	1856	4132	69,2	4,22	0,90	1,98	✓
RT 1000 - 050 - A	RT 1000 - 050 - B	50	1.97	152	5.98	102	4.02			1543	3469	1911	4256	87,9	5,36	1,00	2,20	✓
RT 1000 - 063 - A	RT 1000 - 063 - B	63	2.48	178	7.01	115	4.53			1567	3523	1951	4346	108,1	6,60	1,10	2,43	✓
RT 1000 - 075 - A	RT 1000 - 075 - B	75	2.95	202	7.95	127	5.00			1583	3559	1977	4404	126,8	7,74	1,20	2,65	✓
RT 1000 - 080 - A	RT 1000 - 080 - B	80	3.15	212	8.35	132	5.20	1588	3571	1986	4424	134,6	8,21	1,24	2,73	✓		
RT 1000 - 100 - A	RT 1000 - 100 - B	100	3.94	252	9.92	152	5.98	1605	3608	2013	4485	165,8	10,12	1,40	3,09	✓		
RT 1000 - 125 - A	RT 1000 - 125 - B	125	4.92	302	11.89	177	6.97	1619	3639	2036	4537	204,7	12,49	1,60	3,53	✓		

♦ Disposable

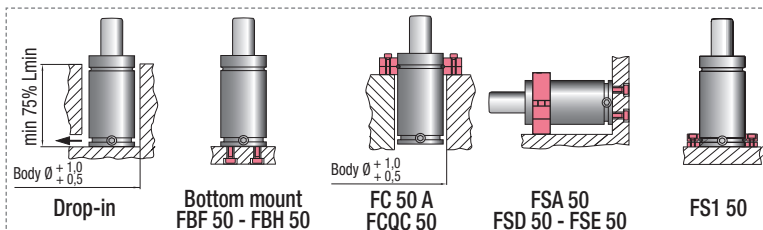

HOW TO ORDER

p. 101

INSTALLATION GUIDELINE

p. 205



OSAS + OSM = OVER STROKE ACTIVE SAFETY + OVER STROKE MARKER

ACTIVE SAFETY



OSAS



USAS



OPAS

Il nuovo codice sarà fornito solo ad esaurimento del vecchio

The new code will be supplied only when the old will be out of stock

Der neue Kode wird nur angegeben, wenn der alte nicht mehr lieferbar ist

Le nouveau code sera fourni uniquement lorsque le vieux stock sera écoulé

El nuevo código será suministrado sólo cuando se agoten las existencias del antiguo

O novo código irá ser fornecido apenas quando o antigo esgotar stock



* F_{1i} =

Isothermal end force at 100% Cu



p. 16

** F_{1p} =

Polytrophic end force at 100% Cu

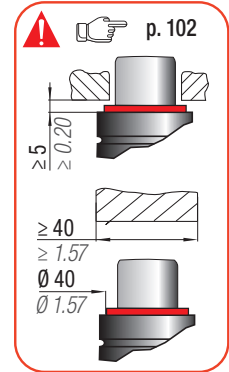
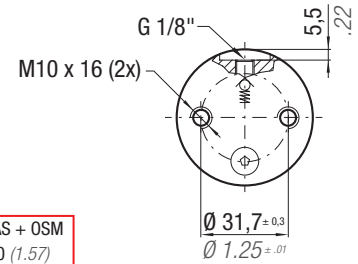
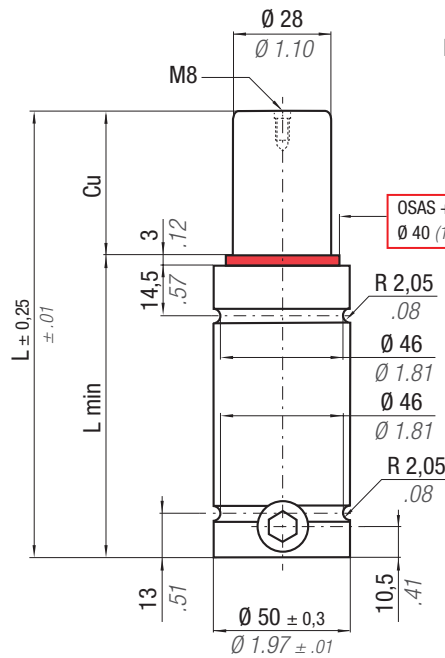

N₂	0 - 80 °C 32 - 176 °F	ΔP ± 0,33 %/°C	P max 170 bar 2465 psi	P min 20 bar 290 psi	S 6,15 cm ² 0,953 in ²	SPM ~ 20 - 100 (at 20°C)	Max Speed 1,8 m/s 70,8 in/s	Maintenance kit 39BMRV01000C
----------------------	--------------------------	--------------------------	-------------------------------------	-----------------------------------	-----------------------------------------------------------	---------------------------------------	------------------------------------------	----------------------------------------

CODE PHASING OUT from 04/2021	NEW	Cu		L		L min		F ₀		F _{1i} *		F _{1p} **		V ₀		~Kg	~lb	PED 2014/68/EU
		mm	inch	mm	inch	mm	inch	daN	lb	daN	lb	daN	lb	cm ³	in ³			
RT 1200 - 010 - A	♦ RT 1200 - 010 - B	10	0.39	72	2.83	62	2.44	1047 ± 5%	2354	1473	3311	1685	3754	25,5	1,56	0,68	1,50	✓
RT 1200 - 013 - A	♦ RT 1200 - 013 - B	13	0.51	78	3.07	65	2.56			1532	3444	1772	3946	30,2	1,84	0,70	1,54	✓
RT 1200 - 016 - A	RT 1200 - 016 - B	16	0.63	84	3.31	68	2.68			1578	3548	1841	4098	34,9	2,13	0,73	1,61	✓
RT 1200 - 019 - A	RT 1200 - 019 - B	19	0.75	90	3.54	71	2.80			1615	3632	1896	4221	39,6	2,42	0,75	1,65	✓
RT 1200 - 025 - A	RT 1200 - 025 - B	25	0.98	102	4.02	77	3.03			1671	3757	1980	4408	48,9	2,98	0,80	1,76	✓
RT 1200 - 032 - A	RT 1200 - 032 - B	32	1.26	116	4.57	84	3.31			1717	3859	2049	4562	59,8	3,65	0,86	1,90	✓
RT 1200 - 038 - A	RT 1200 - 038 - B	38	1.50	128	5.04	90	3.54			1745	3923	2093	4660	69,2	4,22	0,90	1,98	✓
RT 1200 - 050 - A	RT 1200 - 050 - B	50	1.97	152	5.98	102	4.02			1786	4014	2155	4798	87,9	5,36	1,00	2,20	✓
RT 1200 - 063 - A	RT 1200 - 063 - B	63	2.48	178	7.01	115	4.53			1814	4079	2199	4899	108,1	6,60	1,10	2,43	✓
RT 1200 - 075 - A	RT 1200 - 075 - B	75	2.95	202	7.95	127	5.00			1833	4122	2229	4965	126,8	7,74	1,20	2,65	✓
RT 1200 - 080 - A	RT 1200 - 080 - B	80	3.15	212	8.35	132	5.20	1840	4136	2239	4987	134,6	8,21	1,24	2,73	✓		
RT 1200 - 100 - A	RT 1200 - 100 - B	100	3.94	252	9.92	152	5.98	1860	4181	2270	5057	165,8	10,12	1,40	3,09	✓		
RT 1200 - 125 - A	RT 1200 - 125 - B	125	4.92	302	11.89	177	6.97	1877	4219	2296	5115	204,7	12,49	1,60	3,53	✓		

♦ Disposable

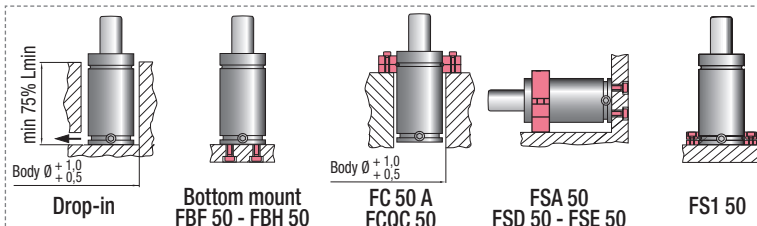

HOW TO ORDER
Hand icon p. 103

INSTALLATION GUIDELINE
Hand icon p. 205



ACTIVE SAFETY



OSAS



USAS



OPAS

OSAS + OSM = OVER STROKE ACTIVE SAFETY + OVER STROKE MARKER

Il nuovo codice sarà fornito solo ad esaurimento del vecchio

The new code will be supplied only when the old will be out of stock

Der neue Kode wird nur angegeben, wenn der alte nicht mehr lieferbar ist

Le nouveau code sera fourni uniquement lorsque le vieux stock sera écoulé

El nuevo código será suministrado sólo cuando se agoten las existencias del antiguo

O novo código irá ser fornecido apenas quando o antigo esgotar stock



* $F_{1i} =$

Isothermal end force at 100% Cu

p. 16

** $F_{1p} =$

Polytrophic end force at 100% Cu

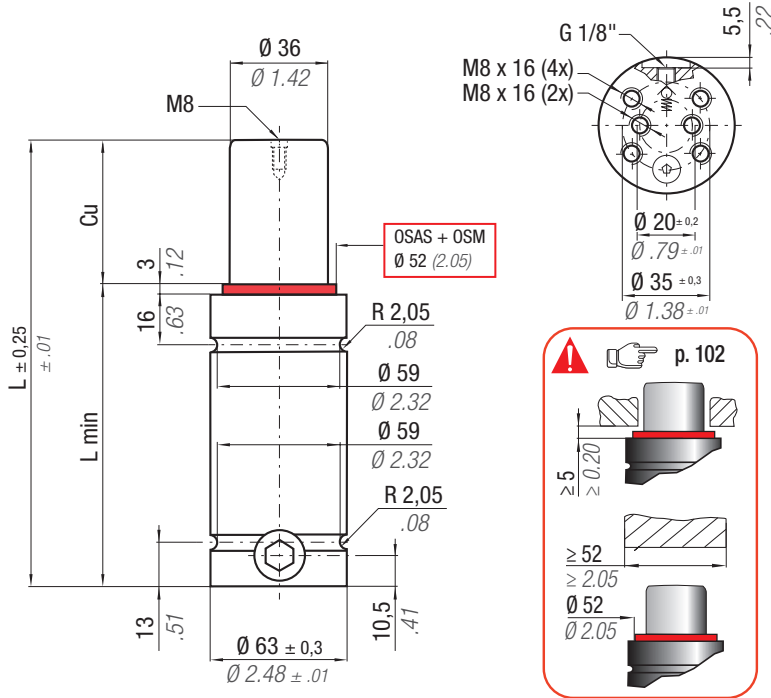

RT

	0 - 80 °C 32 - 176 °F	ΔP ± 0,33 %/°C	P max 150 bar 2175 psi	P min 20 bar 290 psi	S 10,18 cm ² 1.578 in ²	SPM ~ 20 - 100 (at 20°C)	Max Speed 1,8 m/s 70.8 in/s	Maintenance kit 39BMRV01500C
--	--------------------------	---------------------------	-------------------------------------	-----------------------------------	------------------------------------------------------------	---------------------------------------	------------------------------------------	----------------------------------------

CODE PHASING OUT from 04/2021	NEW	Cu		L		L min		F ₀ Initial force		F _{1i} * End force *		F _{1p} ** End force **		V ₀		PED 2014/68/EU		
		mm	inch	mm	inch	mm	inch	daN	lb	daN	lb	daN	lb	cm ³	in ³	~Kg	~lb	✓
RT 1500 - 010 - A	♦ RT 1500 - 010 - B	10	0.39	72	2.83	62	2.44	1530 ± 5%	3440	2078	4671	2406	5409	45	2.72	1,05	2,31	✓
RT 1500 - 013 - A	♦ RT 1500 - 013 - B	13	0.51	78	3.07	65	2.56			2157	4848	2528	5683	53	3.20	1,09	2,40	✓
RT 1500 - 016 - A	♦ RT 1500 - 016 - B	16	0.63	84	3.31	68	2.68			2218	4987	2624	5900	61	3.69	1,13	2,49	✓
RT 1500 - 019 - A	RT 1500 - 019 - B	19	0.75	90	3.54	71	2.80			2267	5097	2701	6073	68	4.17	1,16	2,56	✓
RT 1500 - 025 - A	RT 1500 - 025 - B	25	0.98	102	4.02	77	3.03			2343	5267	2822	6344	84	5.14	1,23	2,71	✓
RT 1500 - 032 - A	RT 1500 - 032 - B	32	1.26	116	4.57	84	3.31			2405	5406	2921	6566	103	6.27	1,31	2,89	✓
RT 1500 - 038 - A	RT 1500 - 038 - B	38	1.50	128	5.04	90	3.54			2444	5493	2984	6708	119	7.23	1,38	3,04	✓
RT 1500 - 050 - A	RT 1500 - 050 - B	50	1.97	152	5.98	102	4.02			2499	5617	3073	6909	150	9.17	1,53	3,37	✓
RT 1500 - 063 - A	RT 1500 - 063 - B	63	2.48	178	7.01	115	4.53			2538	5707	3139	7056	185	11.26	1,69	3,73	✓
RT 1500 - 075 - A	RT 1500 - 075 - B	75	2.95	202	7.95	127	5.00			2565	5765	3182	7152	216	13.19	1,83	4.03	✓
RT 1500 - 080 - A	RT 1500 - 080 - B	80	3.15	212	8.35	132	5.20	2573	5785	3196	7185	229	13.99	1,89	4.17	✓		
RT 1500 - 100 - A	RT 1500 - 100 - B	100	3.94	252	9.92	152	5.98	2601	5847	3242	7287	282	17.21	2,12	4.67	✓		
RT 1500 - 125 - A	RT 1500 - 125 - B	125	4.92	302	11.89	177	6.97	2624	5899	3280	7373	348	21.24	2,41	5.31	✓		

♦ Disposable

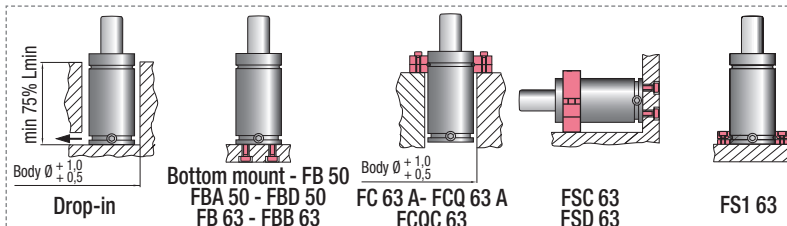

HOW TO ORDER

p. 103

INSTALLATION GUIDELINE

p. 205

RT 2400

K 32 R (Nissan)
SMS DNH 3203n Rev.3 (TOYOTA)

E24.54.815.G (PSA)

EM24.54.700 (Renault)



OSAS + OSM = OVER STROKE ACTIVE SAFETY + OVER STROKE MARKER

ACTIVE SAFETY



OSAS



USAS



OPAS

Il nuovo codice sarà fornito solo ad esaurimento del vecchio

The new code will be supplied only when the old will be out of stock

Der neue Kode wird nur angegeben, wenn der alte nicht mehr lieferbar ist

Le nouveau code sera fourni uniquement lorsque le vieux stock sera écoulé

El nuevo código será suministrado sólo cuando se agoten las existencias del antiguo

O novo código irá ser fornecido apenas quando o antigo esgotar stock

eASU MANIFOLD p. 247

p. 262

* F_{1i} = Isothermal end force at 100% Cu p. 16

** F_{1p} = Polytrophic end force at 100% Cu

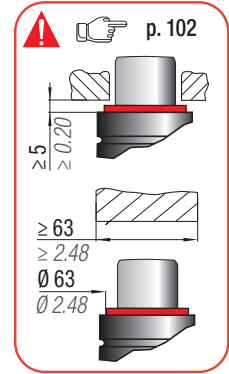
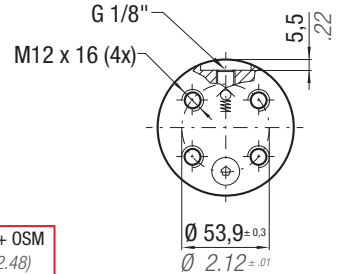
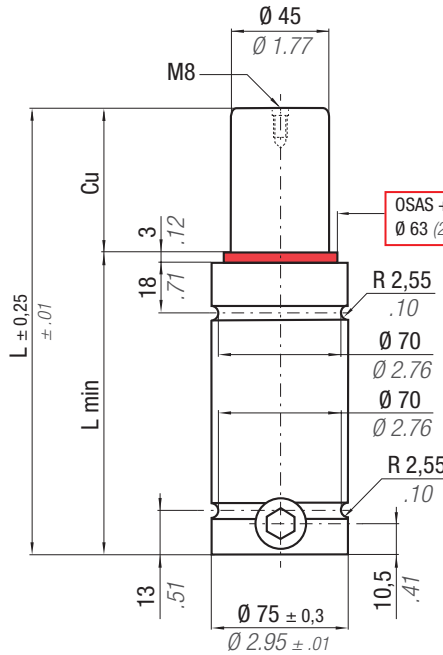

N ₂	0 - 80 °C 32 - 176 °F	ΔP ± 0,33 %/°C	P max 150 bar 2175 psi	P min 20 bar 290 psi	S 15,90 cm ² 2.465 in ²	SPM ~ 20 - 100 (at 20°C)	Max Speed 1,8 m/s 70.8 in/s	Maintenance kit 39BMRV02400D
----------------	--------------------------	---------------------------	------------------------------	----------------------------	-----------------------------------------------------	--------------------------------	-----------------------------------	---------------------------------

CODE PHASING OUT from 04/2021	NEW	Cu		L		L min		F ₀		F _{1i} *		F _{1p} **		V ₀		PED 2014/68/EU		
		mm	inch	mm	inch	mm	inch	daN	lb	daN	lb	daN	lb	cm ³	in ³		~Kg	~lb
RT 2400 - 010 - A	♦ RT 2400 - 010 - B	10	0.39	79	3.11	69	2.72	2385 ± 5%	5362	3146	7073	3606	8106	77	4.67	1,44	3.17	✓
RT 2400 - 013 - A	♦ RT 2400 - 013 - B	13	0.51	85	3.35	72	2.83			3272	7356	3799	8539	89	5.41	1,64	3.62	✓
RT 2400 - 016 - A	♦ RT 2400 - 016 - B	16	0.63	91	3.58	75	2.95			3374	7586	3957	8895	101	6.15	1,74	3.84	✓
RT 2400 - 019 - A	♦ RT 2400 - 019 - B	19	0.75	97	3.82	78	3.07			3459	7776	4089	9193	113	6.88	1,78	3.92	✓
RT 2400 - 025 - A	RT 2400 - 025 - B	25	0.98	109	4.29	84	3.31			3591	8073	4297	9661	137	8.34	1,88	4.14	✓
RT 2400 - 032 - A	RT 2400 - 032 - B	32	1.26	123	4.84	91	3.58			3703	8325	4476	10063	165	10.06	1,99	4.39	✓
RT 2400 - 038 - A	RT 2400 - 038 - B	38	1.50	135	5.31	97	3.82			3776	8488	4594	10327	189	11.52	2,08	4.59	✓
RT 2400 - 050 - A	RT 2400 - 050 - B	50	1.97	159	6.26	109	4.29			3882	8726	4766	10713	237	14.46	2,27	5.00	✓
RT 2400 - 063 - A	RT 2400 - 063 - B	63	2.48	185	7.28	122	4.80			3960	8902	4894	11001	289	17.63	2,48	5.47	✓
RT 2400 - 075 - A	RT 2400 - 075 - B	75	2.95	209	8.23	134	5.28			4012	9020	4980	11195	337	20.57	2,67	5.89	✓
RT 2400 - 080 - A	RT 2400 - 080 - B	80	3.15	219	8.62	139	5.47	4030	9060	5009	11261	357	21.79	2,74	6.04	✓		
RT 2400 - 100 - A	RT 2400 - 100 - B	100	3.94	259	10.20	159	6.26	4087	9187	5102	11471	437	26.67	3,06	6.75	✓		
RT 2400 - 125 - A	RT 2400 - 125 - B	125	4.92	309	12.17	184	7.24	4134	9295	5182	11649	537	32.79	3,45	7.61	✓		

♦ Disposable

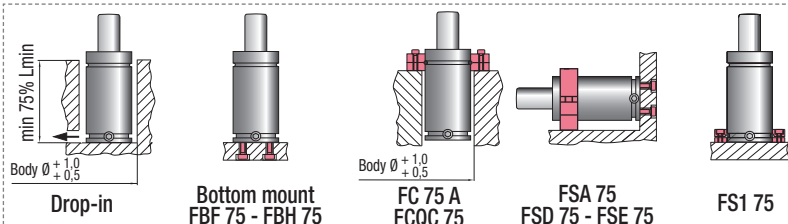

HOW TO ORDER p. 103

INSTALLATION GUIDELINE p. 205

K 32 R (Nissan)	E24.54.815.G (PSA)	EM24.54.700 (Renault)
SMS DNH 3203n Rev.3 (TOYOTA)		

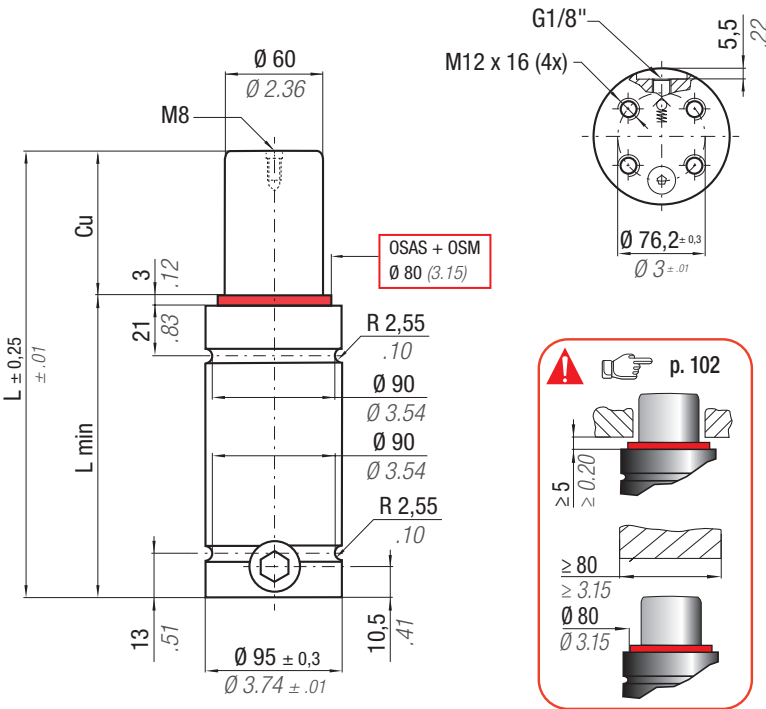

OSAS + OSM = OVER STROKE ACTIVE SAFETY + OVER STROKE SAFETY MARKER



Il nuovo codice sarà fornito solo ad esaurimento del vecchio
 The new code will be supplied only when the old will be out of stock
 Der neue Kode wird nur angegeben, wenn der alte nicht mehr lieferbar ist
 Le nouveau code sera fourni uniquement lorsque le vieux stock sera écoulé
 El nuevo código será suministrado sólo cuando se agoten las existencias del antiguo
 O novo código irá ser fornecido apenas quando o antigo esgotar stock

ACTIVE SAFETY



OSAS



USAS



OPAS

easu MANIFOLD p. 247

p. 262

* F_{1i} =

Isothermal end force at 100% Cu

p. 16

** F_{1p} =

Polytrophic end force at 100% Cu

p. 16

N ₂		0 - 80 °C 32 - 176 °F	ΔP ± 0,33 %/°C	P max 150 bar 2175 psi	P min 20 bar 290 psi	S 28,27 cm ² 4.382 in ²	SPM ~ 20 - 100 (at 20°C)	Max Speed 1,8 m/s 70.8 in/s	Maintenance kit 39BMRV04200C
CODE	NEW	Cu	L	L min	F ₀	F _{1i} *	F _{1p} **	V ₀	PED
PHASING OUT from 04/2021		mm inch	mm inch	mm inch	Initial force daN lb	End force * daN lb	End force ** daN lb	cm ³ in ³	~Kg ~lb 2014/68/EU
RT 4200 - 016 - A	◆ RT 4200 - 016 - B	16 0.63	94 3.70	78 3.07	4240 9532 ± 5%	6103 13720	7197 16179	172 10.48	2,97 6.55 ✓
RT 4200 - 019 - A	◆ RT 4200 - 019 - B	19 0.75	100 3.94	81 3.19		6269 14093	7458 16767	192 11.71	3,05 6.72 ✓
RT 4200 - 025 - A	RT 4200 - 025 - B	25 0.98	112 4.41	87 3.43		6531 14682	7874 17702	232 14.18	3,20 7.05 ✓
RT 4200 - 032 - A	RT 4200 - 032 - B	32 1.26	126 4.96	94 3.70		6755 15186	8236 18515	280 17.06	3,37 7.43 ✓
RT 4200 - 038 - A	RT 4200 - 038 - B	38 1.50	138 5.43	100 3.94		6902 15517	8475 19052	320 19.52	3,52 7.76 ✓
RT 4200 - 050 - A	RT 4200 - 050 - B	50 1.97	162 6.38	112 4.41		7117 16001	8827 19844	401 24.45	3,82 8.42 ✓
RT 4200 - 063 - A	RT 4200 - 063 - B	63 2.48	188 7.40	125 4.92		7278 16361	9092 20440	488 29.80	4,14 9.13 ✓
RT 4200 - 075 - A	RT 4200 - 075 - B	75 2.95	212 8.35	137 5.39		7386 16604	9272 20843	569 34.73	4,44 9.79 ✓
RT 4200 - 080 - A	RT 4200 - 080 - B	80 3.15	222 8.74	142 5.59		7423 16687	9333 20982	603 36.79	4,57 10.08 ✓
RT 4200 - 100 - A	RT 4200 - 100 - B	100 3.94	262 10.31	162 6.38		7539 16949	9529 21421	738 45.01	5,07 11.18 ✓
RT 4200 - 125 - A	RT 4200 - 125 - B	125 4.92	312 12.28	187 7.36	7639 17173	9696 21798	906 55.29	5,69 12.54 ✓	

◆ Disposable

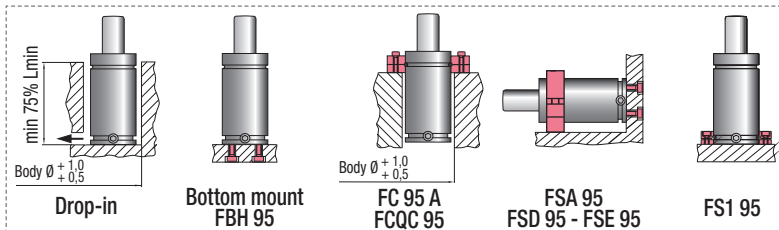

HOW TO ORDER

p. 103

INSTALLATION GUIDELINE

p. 205



OSAS + OSM = OVER STROKE ACTIVE SAFETY + OVER STROKE MARKER

ACTIVE SAFETY



OSAS



USAS



OPAS

Il nuovo codice sarà fornito solo ad esaurimento del vecchio

The new code will be supplied only when the old will be out of stock

Der neue Kode wird nur angegeben, wenn der alte nicht mehr lieferbar ist

Le nouveau code sera fourni uniquement lorsque le vieux stock sera écoulé

El nuevo código será suministrado sólo cuando se agoten las existencias del antiguo

O novo código irá ser fornecido apenas quando o antigo esgotar stock

easU MANIFOLD p. 247

p. 262

* F_{1i} = Isothermal end force at 100% Cu p. 16

** F_{1p} = Polytrophic end force at 100% Cu

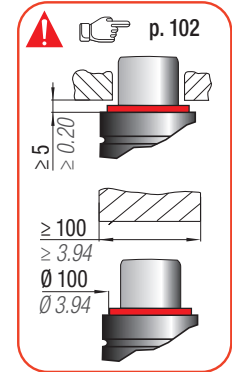
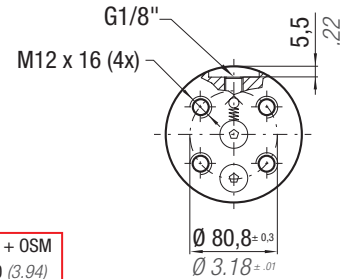
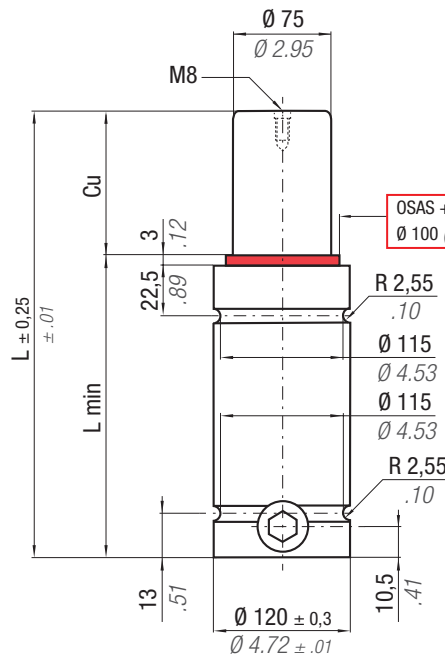

	0 - 80 °C 32 - 176 °F	ΔP ± 0,33 %/°C	P max 150 bar 2175 psi	P min 20 bar 290 psi	S 44,18 cm ² 6,848 in ²	SPM ~ 20 - 100 (at 20°C)	Max Speed 1,8 m/s 70,8 in/s	Maintenance kit 39BMRV06600C
--	--------------------------	---------------------------	------------------------------	----------------------------	-----------------------------------------------------	--------------------------------	-----------------------------------	---------------------------------

CODE PHASING OUT from 04/2021	NEW	Cu		L		L min		F ₀		F _{1i} *		F _{1p} **		V ₀		~Kg	~lb	PED 2014/68/EU
		mm	inch	mm	inch	mm	inch	daN	lb	daN	lb	daN	lb	cm ³	in ³			
RT 6600 - 016 - A	♦ RT 6600 - 016 - B	16	0.63	104	4.09	88	3.46	6630 ± 5%	14904	9056	20359	10500	23606	306	18.69	5,41	11,93	✓
RT 6600 - 019 - A	♦ RT 6600 - 019 - B	19	0.75	110	4.33	91	3.58			9306	20920	10887	24474	338	20.64	5,53	12,19	✓
RT 6600 - 025 - A	RT 6600 - 025 - B	25	0.98	122	4.80	97	3.82			9712	21832	11521	25901	402	24.54	5,77	12,72	✓
RT 6600 - 032 - A	RT 6600 - 032 - B	32	1.26	136	5.35	104	4.09			10073	22644	12093	27187	477	29.08	6,05	13,34	✓
RT 6600 - 038 - A	RT 6600 - 038 - B	38	1.50	148	5.83	110	4.33			10316	23192	12483	28063	541	32.98	6,25	13,78	✓
RT 6600 - 050 - A	RT 6600 - 050 - B	50	1.97	172	6.77	122	4.80			10683	24016	13075	29394	668	40.78	6,77	14,93	✓
RT 6600 - 063 - A	RT 6600 - 063 - B	63	2.48	198	7.80	135	5.31			10964	24648	13534	30427	807	49.23	7,25	15,98	✓
RT 6600 - 075 - A	RT 6600 - 075 - B	75	2.95	222	8.74	147	5.79			11157	25083	13852	31141	935	57.03	7,77	17,13	✓
RT 6600 - 080 - A	RT 6600 - 080 - B	80	3.15	232	9.13	152	5.98			11225	25234	13963	31390	988	60.28	7,97	17,57	✓
RT 6600 - 100 - A	RT 6600 - 100 - B	100	3.94	272	10.71	172	6.77			11439	25715	14318	32188	1201	73.28	8,76	19,31	✓
RT 6600 - 125 - A	RT 6600 - 125 - B	125	4.92	322	12.68	197	7.76	11625	26133	14628	32885	1467	89.53	9,76	21,52	✓		

♦ Disposable

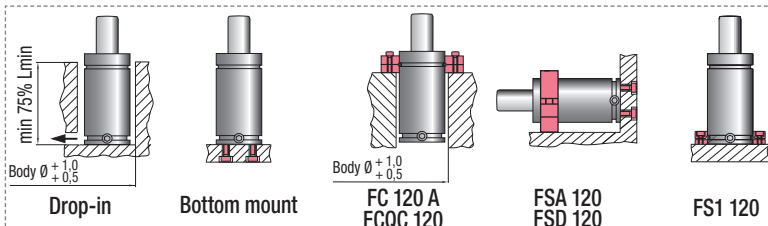

HOW TO ORDER

p. 103

INSTALLATION GUIDELINE

p. 205



ACTIVE SAFETY



OSAS



USAS



OPAS

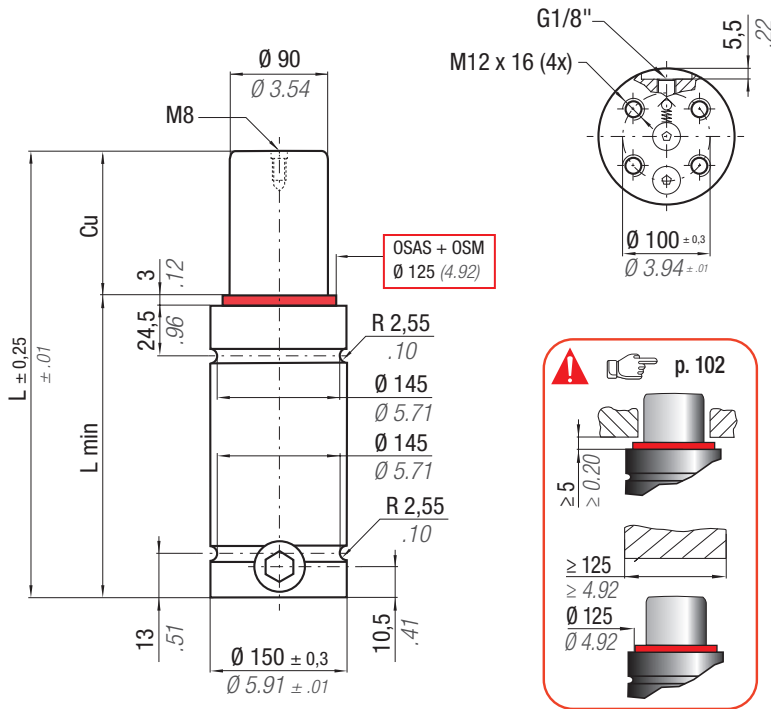

OSAS + OSM = OVER STROKE ACTIVE SAFETY + OVER STROKE MARKER

Il nuovo codice sarà fornito solo ad esaurimento del vecchio

The new code will be supplied only when the old will be out of stock

Der neue Kode wird nur angegeben, wenn der alte nicht mehr lieferbar ist

Le nouveau code sera fourni uniquement lorsque le vieux stock sera écoulé

El nuevo código será suministrado sólo cuando se agoten las existencias del antiguo

O novo código irá ser fornecido apenas quando o antigo esgotar stock

easu MANIPOL **p. 247**

p. 262

* $F_{1i} =$

Isothermal end force at 100% Cu

p. 16

** $F_{1p} =$

Polytrophic end force at 100% Cu

p. 16

		0 - 80 °C 32 - 176 °F	ΔP $\pm 0,33 \% / ^\circ C$	P max 150 bar 2175 psi	P min 20 bar 290 psi	S 63,62 cm ² 9.864 in ²	SPM ~ 20 - 100 (at 20°C)	Max Speed 1,8 m/s 70.8 in/s	Maintenance kit 39BMRV09500C						
CODE	NEW	Cu	L	L min	F0	F_{1i} *	F_{1p} **	V0							
PHASING OUT from 04/2021		mm	inch	mm	inch	daN	lb	daN	lb	cm ³	in ³	~Kg	~lb	2014/68/EU	
RT 9500 - 019 - A	◆ RT 9500 - 019 - B	19	0.75	116	4.57	9540 ± 5% 150 bar 2175 psi + 20 °C +68 °F	13135	29529	15266	34320	513	31.32	9,58	21.12	✓
RT 9500 - 025 - A	RT 9500 - 025 - B	25	0.98	128	5.04		13676	30745	16106	36208	609	37.19	9,95	21.94	✓
RT 9500 - 032 - A	RT 9500 - 032 - B	32	1.26	142	5.59		14157	31826	16862	37908	722	44.03	10,39	22.91	✓
RT 9500 - 038 - A	RT 9500 - 038 - B	38	1.50	154	6.06		14481	32554	17376	39063	818	49.90	10,76	23.72	✓
RT 9500 - 050 - A	RT 9500 - 050 - B	50	1.97	178	7.01		14968	33649	18156	40817	1010	61.63	11,51	25.38	✓
RT 9500 - 063 - A	RT 9500 - 063 - B	63	2.48	204	8.03		15341	34488	18760	42174	1218	74.35	12,32	27.16	✓
RT 9500 - 075 - A	RT 9500 - 075 - B	75	2.95	228	8.98		15597	35064	19177	43113	1411	86.07	13,07	28.81	✓
RT 9500 - 080 - A	RT 9500 - 080 - B	80	3.15	238	9.37		15686	35264	19323	43440	1491	90.97	13,38	29.50	✓
RT 9500 - 100 - A	RT 9500 - 100 - B	100	3.94	278	10.94		15970	35902	19788	44486	1811	110.52	14,63	32.25	✓
RT 9500 - 125 - A	RT 9500 - 125 - B	125	4.92	328	12.91		16216	36456	20195	45399	2212	134.97	16,19	35.69	✓

◆ Disposable

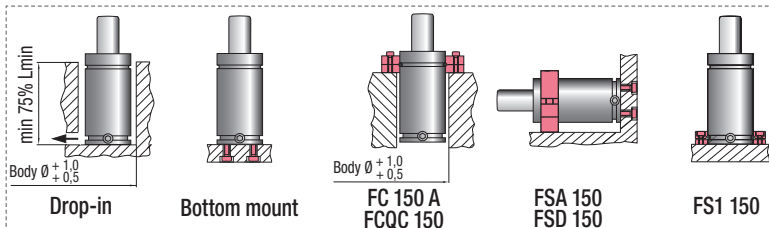

HOW TO ORDER

p. 103

INSTALLATION GUIDELINE

p. 205

MB	Renault	Suzuki

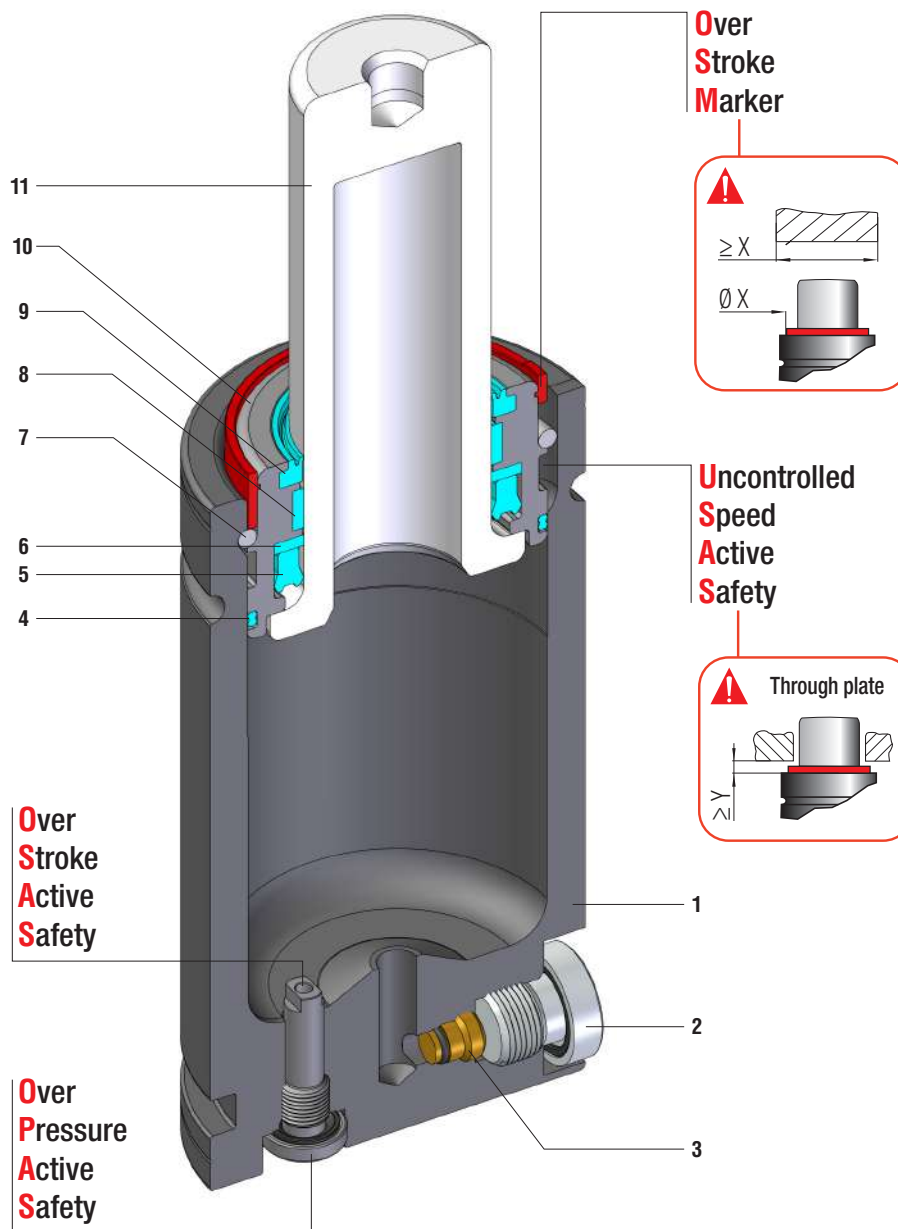

Forze ISO, altezza ridotta - ISO forces, reduced height - ISO Kräfte, Reduzierte Höhe
 Forces ISO, Hauteur réduite - Fuerzas ISO, altura reducida - Forças ISO, altura reduzida

SEALING	ROD SEAL
DESIGN	BUSH - BODY DESIGN

1	Body	5	Rod seal	9	Rod wiper
2	Plug	6	Back-up ring	10	Bush
3	Valve	7	Retaining ring	11	Rod (nitrited superfinished)
4	Dual ring seal	8	Guide ring		

RANGE CHART

Model	Body Ø		Stroke Cu		Initial force F0						
	mm	inch	mm	inch	daN	lb	OSAS	USAS	OPAS	SKUDO	SW
S 500	45	1.77	6 - 125	0.24 - 4.92	470	1057	✓	✓	✓	-	✓
S 750	50	1.97	6 - 125	0.24 - 4.92	740	1664	✓	✓	✓	-	✓
S 1500	75	2.95	25 - 100	0.98 - 3.94	1530	3440	✓	✓	✓	-	✓
S 3000	95	3.74	25 - 100	0.98 - 3.94	2945	6621	✓	✓	✓	-	✓

Built-in as standard
 Optional upon request

HOW TO ORDER

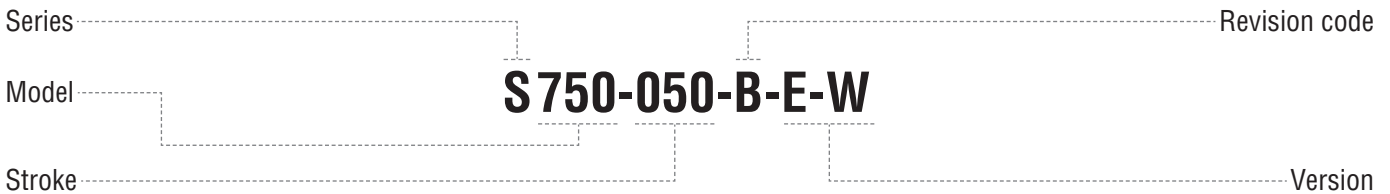

Available versions

S 750-050-C Standard code	S 750-050-C-W Add "-W" to standard code	S 750-050-C-N Add "-N" to standard code	S 750-050-C-N-W Add "-N-W" to standard code	S 750-050-B-E Add "-E" to standard code	S 750-050-B-E-W Add "-E-W" to standard code
Self contained	Self contained + Secondary wiper	Linkable	Linkable + Secondary wiper	Easy Manifold	Easy Manifold + Secondary wiper



OSAS + OSM = OVER STROKE ACTIVE SAFETY + OVER STROKE MARKER

ACTIVE SAFETY



OSAS



USAS



OPAS

Il nuovo codice sarà fornito solo ad esaurimento del vecchio

The new code will be supplied only when the old will be out of stock

Der neue Kode wird nur angegeben, wenn der alte nicht mehr lieferbar ist

Le nouveau code sera fourni uniquement lorsque le vieux stock sera écoulé

El nuevo código será suministrado sólo cuando se agoten las existencias del antiguo

O novo código irá ser fornecido apenas quando o antigo esgotar stock



p. 262

* F_{1i} =

Isothermal end force at 100% Cu



p. 16

** F_{1p} =

Polytropic end force at 100% Cu

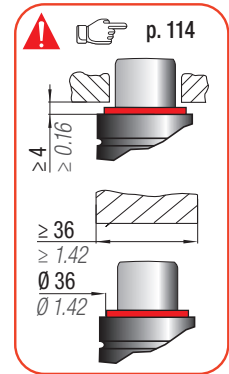
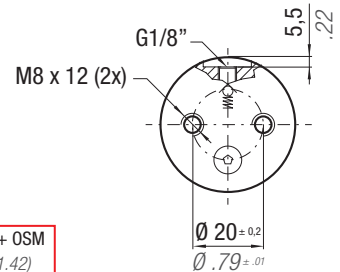
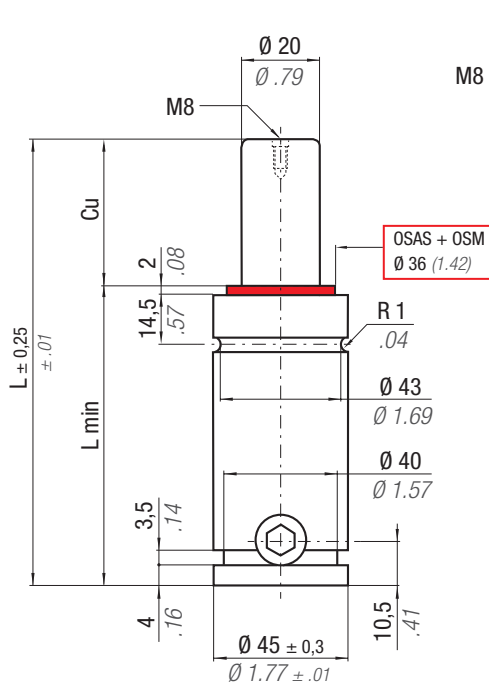

N ₂		0 - 80 °C 32 - 176 °F	ΔP ± 0,33 %/°C	P max 150 bar 2175 psi	P min 20 bar 290 psi	S 3,14 cm ² 0.487 in ²	SPM ~ 40 - 100 (at 20°C)	Max Speed 1,8 m/s 70.8 in/s	Maintenance kit 39BMS00500B	
CODE PHASING OUT from 04/2021	NEW	Cu	L	L min	F ₀	F _{1i} *	F _{1p} **	V ₀	PED 2014/68/EU	
S 500 - 006 - A	◆ S 500 - 006 - B	6 0.24	62 2.44	56 2.20	470 1057 ± 5% 150 bar 2175 psi + 20 °C +68 °F	597 1343	676 1520	10,4 0.63	0,54 1.19	✓
S 500 - 013 - A	◆ S 500 - 013 - B	13 0.51	76 2.99	63 2.48		651 1464	758 1704	17,2 1.05	0,58 1.28	✓
S 500 - 019 - A	S 500 - 019 - B	19 0.75	88 3.46	69 2.72		675 1517	794 1785	22,9 1.40	0,62 1.37	✓
S 500 - 025 - A	S 500 - 025 - B	25 0.98	100 3.94	75 2.95		689 1550	817 1837	28,7 1.75	0,67 1.48	✓
S 500 - 038 - A	S 500 - 038 - B	38 1.50	126 4.96	88 3.46		708 1592	847 1904	41,2 2.51	0,77 1.70	✓
S 500 - 050 - A	S 500 - 050 - B	50 1.97	150 5.91	100 3.94		718 1613	862 1938	52,8 3.22	0,85 1.87	✓
S 500 - 063 - A	S 500 - 063 - B	63 2.48	176 6.93	113 4.45		724 1629	873 1963	65,3 3.98	0,90 1.98	✓
S 500 - 080 - A	S 500 - 080 - B	80 3.15	210 8.27	130 5.12		730 1642	882 1983	81,6 4.98	1,01 2.23	✓
S 500 - 100 - A	S 500 - 100 - B	100 3.94	250 9.84	150 5.91		735 1652	889 2000	100,9 6.16	1,16 2.56	✓
S 500 - 125 - A	S 500 - 125 - B	125 4.92	300 11.81	175 6.89		738 1660	895 2013	124,9 7.62	1,35 2.98	✓

◆ Disposable

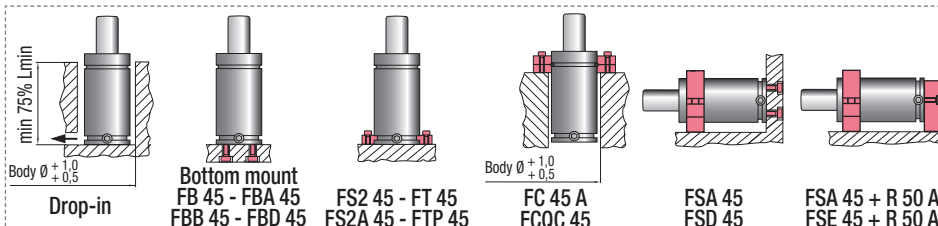

HOW TO ORDER

p. 115

INSTALLATION GUIDELINE

p. 205

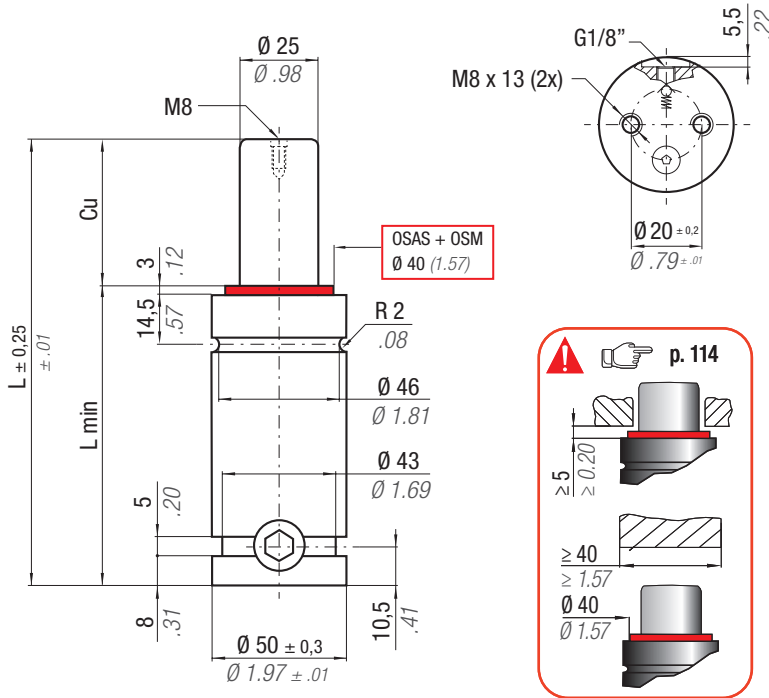

OSAS + OSM = OVER STROKE ACTIVE SAFETY + OVER STROKE MARKER



Il nuovo codice sarà fornito solo ad esaurimento del vecchio
 The new code will be supplied only when the old will be out of stock
 Der neue Kode wird nur angegeben, wenn der alte nicht mehr lieferbar ist
 Le nouveau code sera fourni uniquement lorsque le vieux stock sera écoulé
 El nuevo código será suministrado sólo cuando se agoten las existencias del antiguo
 O novo código irá ser fornecido apenas quando o antigo esgotar stock

ACTIVE SAFETY



OSAS



USAS



OPAS

easu MANIFOLD p. 247

p. 262

* F_{1i} = Isothermal end force at 100% Cu

p. 16

** F_{1p} = Polytrophic end force at 100% Cu

		0 - 80 °C 32 - 176 °F	ΔP ± 0,33 %/°C	P max 150 bar 2175 psi	P min 20 bar 290 psi	S 4,91 cm ² 0,761 in ²	SPM ~ 30 - 80 (at 20°C)	Max Speed 1,8 m/s 70,8 in/s	Maintenance kit 39BMS00750B	
CODE PHASING OUT from 04/2021	NEW	Cu	L	L min	F0	F _{1i} *	F _{1p} **	V0		
S 750 - 006 - B	◆ S 750 - 006 - C	6 0.24	62 2.44	56 2.20	740 1664 ± 5% 150 bar 2175 psi + 20 °C +68 °F	906 2038	1016 2283	18,4 1.12	0,60 1.32	✓
S 750 - 013 - B	◆ S 750 - 013 - C	13 0.51	76 2.99	63 2.48		994 2234	1147 2579	28,7 1.75	0,66 1.46	✓
S 750 - 019 - B	S 750 - 019 - C	19 0.75	88 3.46	69 2.72		1035 2326	1211 2722	37,5 2.29	0,71 1.57	✓
S 750 - 025 - B	S 750 - 025 - C	25 0.98	100 3.94	75 2.95		1062 2387	1253 2818	46,3 2.83	0,75 1.65	✓
S 750 - 038 - B	S 750 - 038 - C	38 1.50	126 4.96	88 3.46		1098 2468	1309 2944	65,5 4.00	0,85 1.87	✓
S 750 - 050 - B	S 750 - 050 - C	50 1.97	150 5.91	100 3.94		1117 2511	1340 3012	83,1 5.07	0,95 2.09	✓
S 750 - 063 - B	S 750 - 063 - C	63 2.48	176 6.93	113 4.45		1130 2541	1362 3061	102,2 6.24	1,05 2.31	✓
S 750 - 080 - B	S 750 - 080 - C	80 3.15	210 8.27	130 5.12		1142 2568	1381 3104	127,2 7.76	1,18 2.60	✓
S 750 - 100 - B	S 750 - 100 - C	100 3.94	250 9.84	150 5.91		1152 2589	1396 3138	156,7 9.56	1,33 2.93	✓
S 750 - 125 - B	S 750 - 125 - C	125 4.92	300 11.81	175 6.89		1159 2607	1408 3166	193,4 11.80	1,52 3.35	✓

◆ Disposable

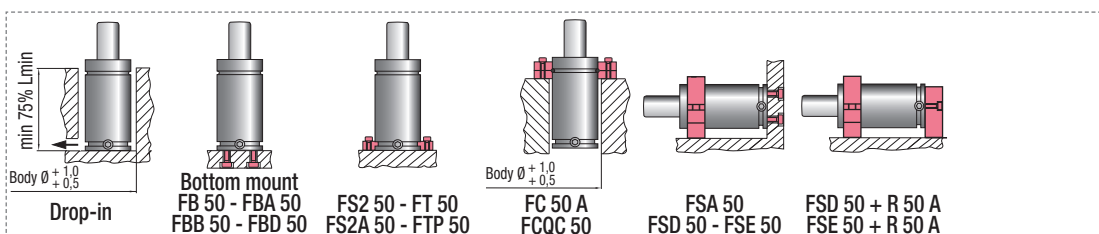

HOW TO ORDER
 p. 115
INSTALLATION GUIDELINE
 p. 205



OSAS + OSM = OVER STROKE ACTIVE SAFETY + OVER STROKE MARKER

ACTIVE SAFETY



OSAS



USAS



OPAS

Il nuovo codice sarà fornito solo ad esaurimento del vecchio

The new code will be supplied only when the old will be out of stock

Der neue Kode wird nur angegeben, wenn der alte nicht mehr lieferbar ist

Le nouveau code sera fourni uniquement lorsque le vieux stock sera écoulé

El nuevo código será suministrado sólo cuando se agoten las existencias del antiguo

O novo código irá ser fornecido apenas quando o antigo esgotar stock

eaSU MANIFOLD p. 247

p. 262

* F_{1i} = Isothermal end force at 100% Cu p. 16

** F_{1p} = Polyphropic end force at 100% Cu

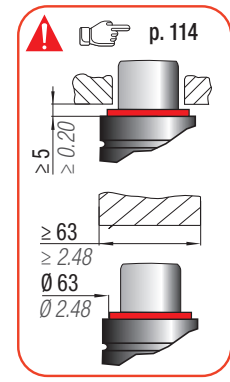
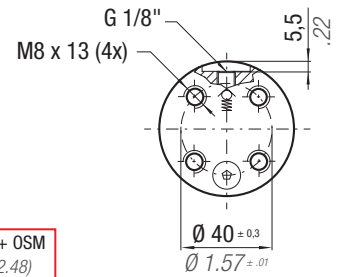
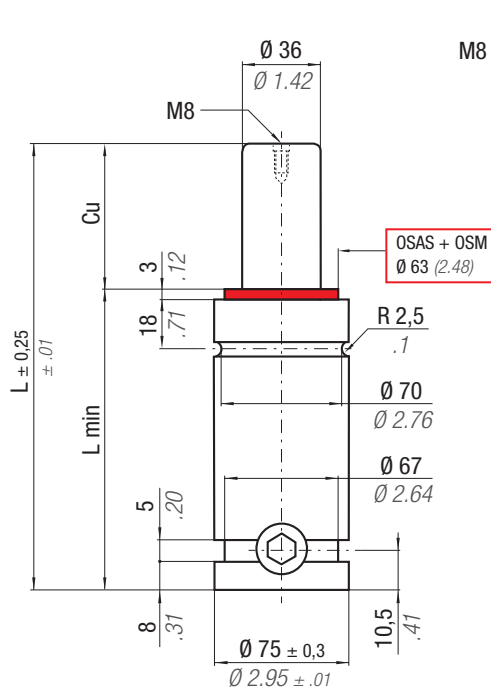

N₂	0 - 80 °C 32 - 176 °F	ΔP ± 0,33 %/°C	P max 150 bar 2175 psi	P min 20 bar 290 psi	S 10,18 cm ² 1,578 in ²	SPM ~ 20 - 80 (at 20°C)	Max Speed 1,8 m/s 70.8 in/s	Maintenance kit 39BMS01500B
----------------------	--------------------------	---------------------------	-------------------------------------	-----------------------------------	------------------------------------------------------------	--------------------------------------	------------------------------------------	---------------------------------------

CODE PHASING OUT from 04/2021	NEW	Cu		L		L min		F ₀ Initial force		F _{1i} * End force *		F _{1p} ** End force **		V ₀		PED 2014/68/EU		
		mm	inch	mm	inch	mm	inch	daN	lb	daN	lb	daN	lb	cm ³	in ³		~Kg	~lb
S 1500 - 025 - A	S 1500 - 025 - B	25	0.98	110	4.33	85	3.35	1530	3440	2238	5031	2655	5969	93	5.65	2,25	4.96	✓
S 1500 - 038 - A	S 1500 - 038 - B	38	1.50	136	5.35	98	3.86	± 5%		2319	5214	2784	6258	131	7.97	2,53	5.58	✓
S 1500 - 050 - A	S 1500 - 050 - B	50	1.97	160	6.30	110	4.33	150 bar 2175 psi		2363	5312	2854	6416	166	10.11	2,78	6.13	✓
S 1500 - 063 - A	S 1500 - 063 - B	63	2.48	186	7.32	123	4.84			2395	5383	2905	6530	204	12.43	3,06	6.75	✓
S 1500 - 080 - A	S 1500 - 080 - B	80	3.15	220	8.66	140	5.51			2422	5445	2949	6630	253	15.46	3,42	7.54	✓
S 1500 - 100 - A	S 1500 - 100 - B	100	3.94	260	10.24	160	6.30	+ 20 °C +68 °F		2444	5494	2984	6708	312	19.03	3,84	8.47	✓

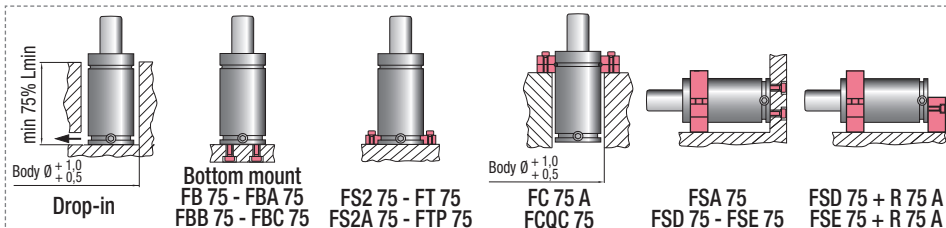

HOW TO ORDER p. 115

INSTALLATION GUIDELINE p. 205



ACTIVE SAFETY



OSAS



USAS



OPAS

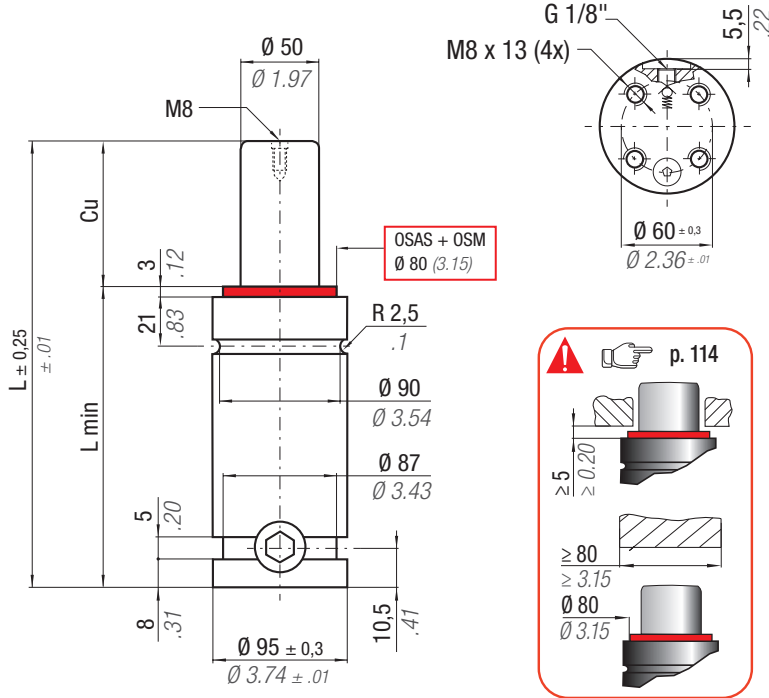

OSAS + OSM = OVER STROKE ACTIVE SAFETY + OVER STROKE MARKER

Il nuovo codice sarà fornito solo ad esaurimento del vecchio

The new code will be supplied only when the old will be out of stock

Der neue Kode wird nur angegeben, wenn der alte nicht mehr lieferbar ist

Le nouveau code sera fourni uniquement lorsque le vieux stock sera épuisé

El nuevo código será suministrado sólo cuando se agoten las existencias del antiguo

O novo código irá ser fornecido apenas quando o antigo esgotar stock

easu MANIFOLD p. 247

p. 262

* $F_{1i} =$

Isothermal end force at 100% Cu p. 16

** $F_{1p} =$

Polytrophic end force at 100% Cu p. 16

	0 - 80 °C 32 - 176 °F	ΔP ± 0,33 %/°C	P max 150 bar 2175 psi	P min 20 bar 290 psi	S 19,63 cm ² 3.043 in ²	SPM ~ 15 - 60 (at 20°C)	Max Speed 1,8 m/s 70.8 in/s	Maintenance kit 39BMS03000B
--	--------------------------	---------------------------	-------------------------------------	-----------------------------------	------------------------------------------------------------	--------------------------------------	------------------------------------------	---------------------------------------

CODE PHASING OUT from 04/2021	NEW	Cu		L		L min		F ₀ Initial force		F _{1i} * End force *		F _{1p} ** End force **		V ₀		PED 2014/68/EU		
		mm	inch	mm	inch	mm	inch	daN	lb	daN	lb	daN	lb	cm ³	in ³	~Kg	~lb	✓
S 3000 - 025 - A	S 3000 - 025 - B	25	0.98	120	4.72	95	3.74	2945	6621	4562	10256	5511	12390	160	9.73	4,13	9.11	✓
S 3000 - 038 - A	S 3000 - 038 - B	38	1.50	146	5.75	108	4.25	± 5%		4779	10744	5862	13178	223	13.63	4,61	10.16	✓
S 3000 - 050 - A	S 3000 - 050 - B	50	1.97	170	6.69	120	4.72	150 bar 2175 psi		4900	11016	6060	13623	282	17.21	5,04	11.11	✓
S 3000 - 063 - A	S 3000 - 063 - B	63	2.48	196	7.72	133	5.24			4988	11214	6205	13949	346	21.10	5,51	12.15	✓
S 3000 - 080 - A	S 3000 - 080 - B	80	3.15	230	9.06	150	5.91			5066	11389	6334	14239	429	26.19	6,13	13.51	✓
S 3000 - 100 - A	S 3000 - 100 - B	100	3.94	270	10.63	170	6.69	+ 20 °C +68 °F		5128	11528	6437	14470	527	32.17	6,86	15.12	✓

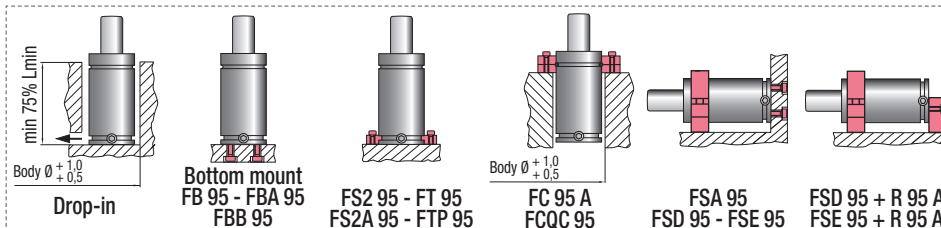

HOW TO ORDER

p. 115

INSTALLATION GUIDELINE

p. 205

ISO	VDI	BMW	FCA
Ford	Mazda	MB	Nissan
PSA	Renault	Suzuki	VW

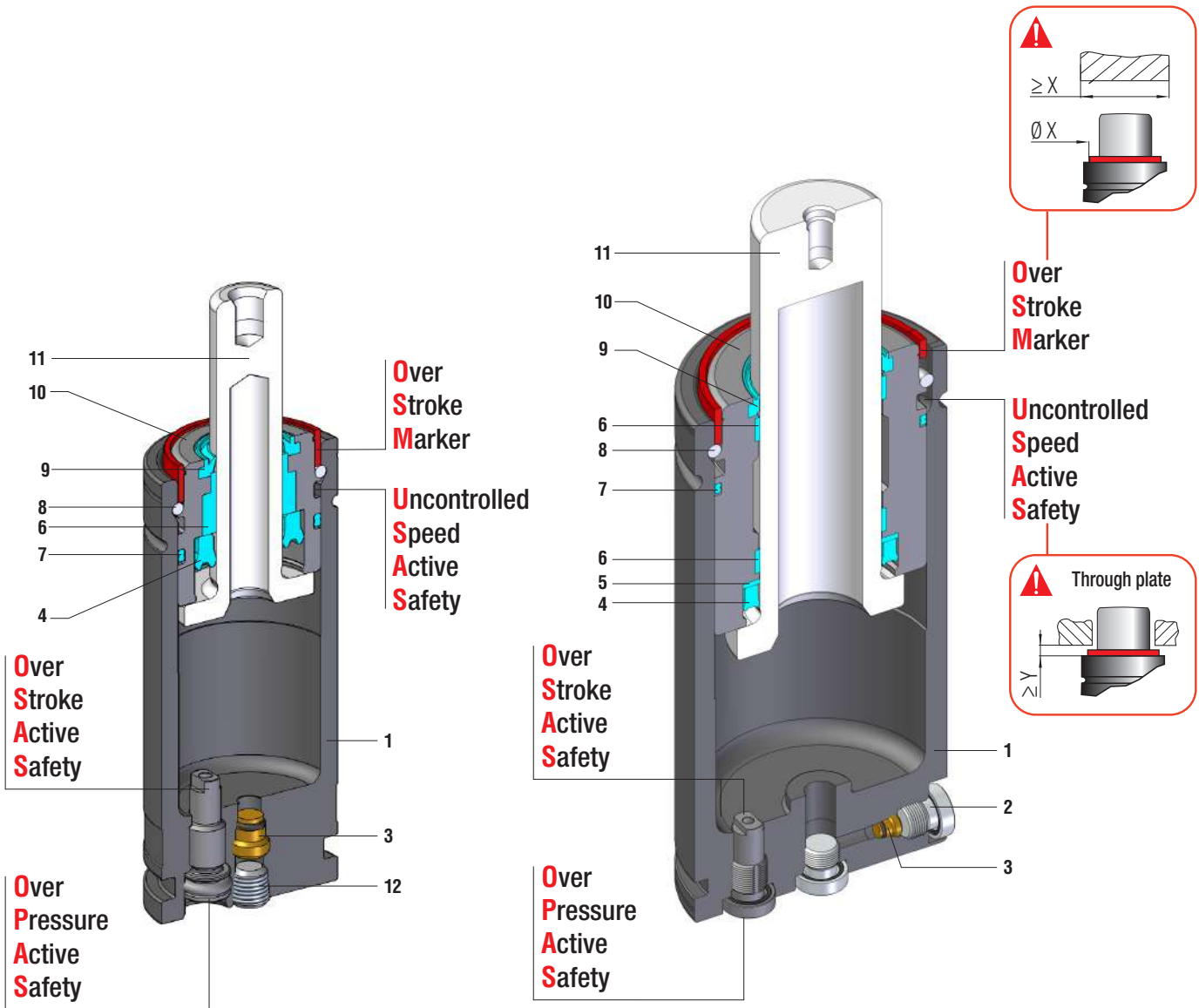

SC 200

SC 150; 250 ÷ SC 10000

ISO 11901 standard - ISO 11901 standard - ISO 11901 standard
 Conforme ISO 11901 - ISO 11901 standard - Norma ISO 11901

SEALING	ROD SEAL
DESIGN	BUSH - BODY DESIGN

1	Body	5	Back-up ring	9	Rod wiper
2	Plug	6	Guide ring	10	Bush
3	Valve	7	Dual ring seal	11	Rod (nitrited superfinished)
4	Rod seal	8	Retaining ring	12	Stopper

RANGE CHART

Model	Body Ø		Stroke Cu		Initial force F0						
	mm	inch	mm	inch	daN	lb	OSAS	USAS	OPAS	SKUDO	SW
SC 150	32	1.26	10 - 125	0.39 - 4.92	170	382	✓	✓	✓	-	✓
SC 200	32	1.26	10 - 125	0.39 - 4.92	170	382	✓	✓	✓	-	✓
SC 250	38	1.50	10 - 125	0.39 - 4.92	260	585	✓	✓	✓	-	✓
SCF 250	M 38 X 1,5		10 - 125	0.39 - 4.92	260	585	✓	✓	✓	-	✓
SC 500	45	1.77	10 - 200	0.39 - 6.30	470	1057	✓	✓	✓	-	✓
SC 750	50	1.97	13 - 300	0.51 - 11.81	740	1664	✓	✓	✓	-	✓
SC 1500	75	2.95	13 - 300	0.51 - 11.81	1530	3440	✓	✓	✓	-	✓
SC 3000	95	3.74	13 - 300	0.51 - 11.81	2945	6621	✓	✓	✓	-	✓
SC 5000	120	4.72	25 - 300	0.98 - 11.81	4980	11195	✓	✓	✓	-	✓
SC 7500	150	5.91	25 - 300	0.98 - 11.81	7540	16950	✓	✓	✓	-	✓
SC 10000	195	7.68	25 - 300	0.98 - 11.81	10600	23830	✓	✓	✓	-	✓

✓ Built-in as standard

✓ Optional upon request

HOW TO ORDER

Series _____ Revision code _____

Model **SC 1500-050-E-E-W**

Stroke _____ Version _____

SC
SCF

Available versions

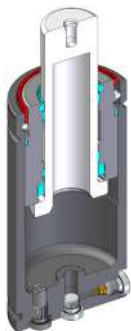

SC 1500-050-E
Standard code

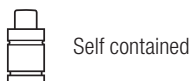

Self contained

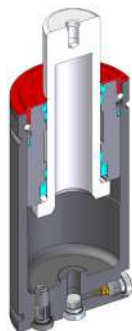

SC 1500-050-E-W
Add "-W" to standard code



Self contained



+ Secondary wiper

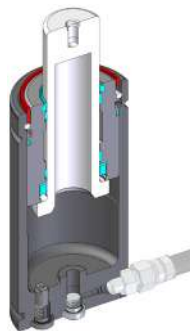

SC 1500-050-E-N
Add "-N" to standard code

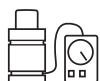

Linkable

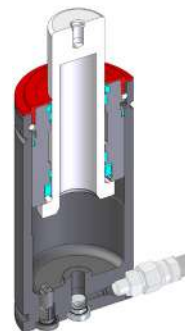

SC 1500-050-E-N-W
Add "-N-W" to standard code

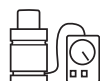

Linkable



+ Secondary wiper

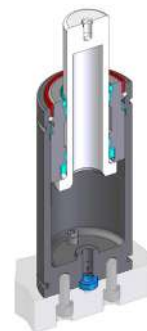

SC 1500-050-E-E
Add "-E" to standard code

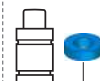

Easy Manifold

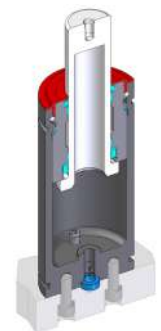

SC 1500-050-E-E-W
Add "-E-W" to standard code

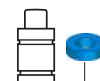

Easy Manifold



+ Secondary wiper

B2 4006 (BMW)	075.90.55 (FCA)	B8 3180 220 000 001(MB)	E24.54.815.G (PSA)
EM24.54.700 (Renault)			



OSAS + OSM = OVER STROKE ACTIVE SAFETY + OVER STROKE MARKER

ACTIVE SAFETY



Il nuovo codice sarà fornito solo ad esaurimento del vecchio

The new code will be supplied only when the old will be out of stock

Der neue Kode wird nur angegeben, wenn der alte nicht mehr lieferbar ist

Le nouveau code sera fourni uniquement lorsque le vieux stock sera épuisé

El nuevo código será suministrado sólo cuando se agoten las existencias del antiguo

O novo código irá ser fornecido apenas quando o antigo esgotar stock



easU MANIFOLD p. 247

p. 262

* F_{1i} = Isothermal end force at 100% Cu p. 16

** F_{1p} = Polytropic end force at 100% Cu

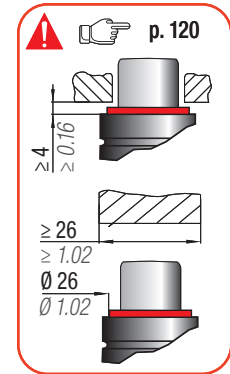
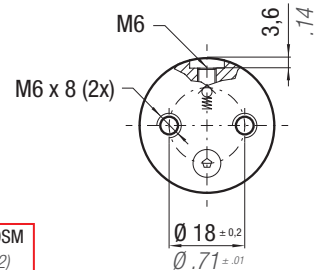
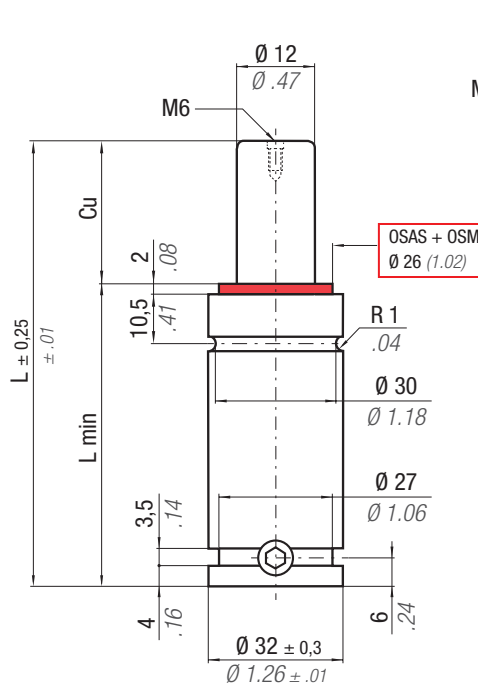

		0 - 80 °C 32 - 176 °F	ΔP ± 0,33 %/°C	P max 150 bar 2175 psi	P min 20 bar 290 psi	S 1,13 cm ² 0.175 in ²	SPM ~ 80 - 100 (at 20°C)	Max Speed 1,8 m/s 70.8 in/s	Maintenance kit 39BMSC00150E	
CODE PHASING OUT from 04/2021	NEW	Cu	L	L min	F ₀ Initial force	F _{1i} * End force *	F _{1p} ** End force **	V ₀		
SC 150 - 010 - D	◆ SC 150 - 010 - E	10 0.39	70 2.76	60 2.36	170 382 ± 5% 150 bar 2175 psi + 20 °C +68 °F	192 431	209 469	11,6 0.71	0,28 0.62	✓
SC 150 - 013 - D	◆ SC 150 - 013 - E	12,7 0.51	75,4 2.97	62,7 2.47		195 438	213 479	13,1 0.80	0,29 0.64	✓
SC 150 - 016 - D	SC 150 - 016 - E	16 0.63	82 3.23	66 2.60		198 445	218 490	14,8 0.90	0,30 0.66	✓
SC 150 - 025 - D	SC 150 - 025 - E	25 0.98	100 3.94	75 2.95		203 457	226 508	20,0 1.22	0,33 0.73	✓
SC 150 - 038 - D	SC 150 - 038 - E	38 1.50	126 4.96	88 3.46		208 467	233 523	27,3 1.67	0,36 0.79	✓
SC 150 - 050 - D	SC 150 - 050 - E	50 1.97	150 5.91	100 3.94		211 473	237 532	34,1 2.08	0,40 0.88	✓
SC 150 - 063 - D	SC 150 - 063 - E	63,5 2.48	177 6.97	113,5 4.47		212 478	239 538	41,7 2.54	0,44 0.97	✓
SC 150 - 080 - D	SC 150 - 080 - E	80 3.15	210 8.27	130 5.12		214 481	242 544	50,9 3.11	0,49 1.08	✓
SC 150 - 100 - D	SC 150 - 100 - E	100 3.94	250 9.84	150 5.91		216 485	245 550	61,6 3.76	0,55 1.21	✓
SC 150 - 125 - D	SC 150 - 125 - E	125 4.92	300 11.81	175 6.89		218 490	247 556	74,7 4.56	0,64 1.41	✓

◆ Disposable

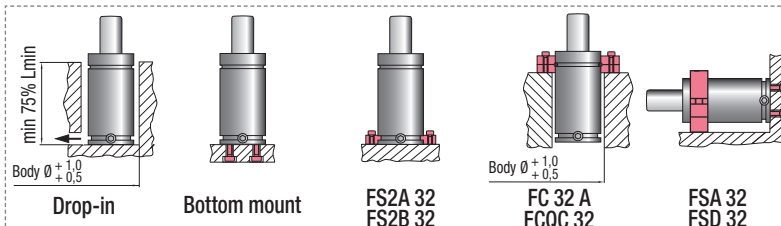

HOW TO ORDER

p. 121

INSTALLATION GUIDELINE

p. 205

ISO 11901 - 1	VDI 3003	B2 4006 (BMW)	075.90.55 (FCA)
B8 3180 220 000 001(MB)	E24.54.815.G (PSA)	EM24.54.700 (Renault)	39D 878 (VW)
90.25.00 (GM)			



ACTIVE SAFETY



OPAS

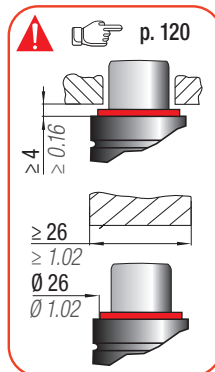
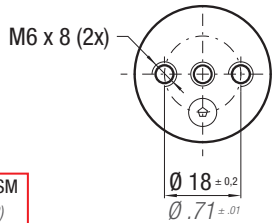
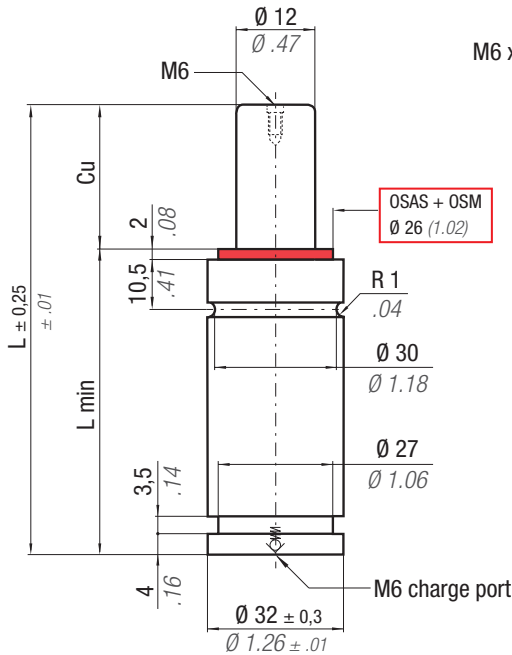

OSAS + OSM = OVER STROKE ACTIVE SAFETY + OVER STROKE MARKER

easu MANIFOLD p. 247

p. 262

* F_{1i} = Isothermal end force at 100% Cu p. 16

** F_{1p} = Polytrophic end force at 100% Cu

HOW TO ORDER

SC 200 - 050 - A - YW Force color code

Force color code	P		F ₀	
	bar	psi	Initial force ± 5% at +20°C +68°F	
	daN	lb	daN	lb
GR	45	653	50	112
BU	90	1305	100	225
RD	135	1958	150	337
YW	180	2610	200	450
BK	20-180	290-2610	22-200	49-450

Pressione da specificare in fase d'ordine.
 Pressure to be specified when ordering.
 Druck bei Bestellung anzugeben.
 Pression à préciser lors de la commande.
 La presión se debe especificar al realizar el pedido.
 Pressão a ser especificada no pedido.

CODE	Cu		L		L min		F _{1i} *		F _{1p} **		V ₀		Maintenance kit	
	mm	inch	mm	inch	mm	inch	daN	lb	daN	lb	cm ³	in ³	~Kg	~lb
◆ SC 200 - 010 - A ...	10	0.39	70	2.76	60	2.36	1,15 x F0		1,28 x F0		9,6	0.59	0,26	0.56
◆ SC 200 - 013 - A ...	12,7	0.51	75,4	2.97	62,7	2.47	1,17 x F0		1,30 x F0		11,1	0.68	0,26	0.58
SC 200 - 016 - A ...	16	0.63	82	3.23	66	2.60	1,19 x F0		1,33 x F0		13,0	0.79	0,27	0.60
SC 200 - 025 - A ...	25	0.98	100	3.94	75	2.95	1,22 x F0		1,37 x F0		18,0	1.10	0,30	0.65
SC 200 - 038 - A ...	38	1.50	126	4.96	88	3.46	1,24 x F0		1,40 x F0		25,3	1.54	0,33	0.73
SC 200 - 050 - A ...	50	1.97	150	5.91	100	3.94	1,25 x F0		1,42 x F0		32,0	1.95	0,37	0.81
SC 200 - 063 - A ...	63,5	2.48	177	6.97	113,5	4.47	1,26 x F0		1,43 x F0		39,6	2.42	0,41	0.89
SC 200 - 080 - A ...	80	3.15	210	8.27	130	5.12	1,26 x F0		1,44 x F0		48,9	2.98	0,45	0.99
SC 200 - 100 - A ...	100	3.94	250	9.84	150	5.91	1,27 x F0		1,46 x F0		59,6	3.64	0,51	1.13
SC 200 - 125 - A ...	125	4.92	300	11.81	175	6.89	1,28 x F0		1,47 x F0		72,7	4.44	0,59	1.30

◆ Disposable

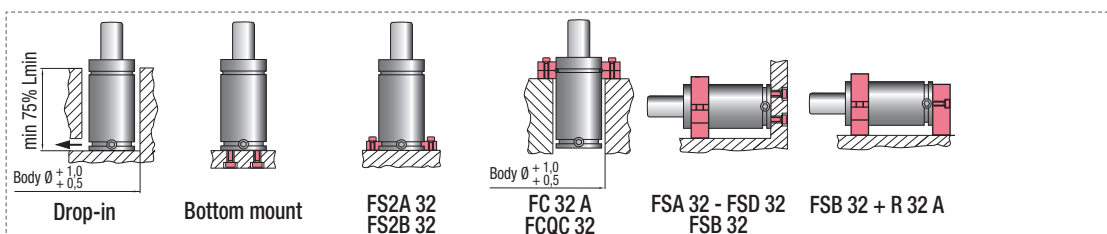

HOW TO ORDER

p. 121

INSTALLATION GUIDELINE

p. 205

ISO 11901 - 1	VDI 3003	B2 4006 (BMW)	075.90.55 (FCA)
B8 3180 220 000 001(MB)	K 32 S (Nissan)	E24.54.815.G (PSA)	EM24.54.700 (Renault)
SES-K 5404e (Suzuki)	39D 878 (VW)		



OSAS + OSM = OVER STROKE ACTIVE SAFETY + OVER STROKE MARKER

ACTIVE SAFETY



OSAS



USAS



OPAS

Il nuovo codice sarà fornito solo ad esaurimento del vecchio

The new code will be supplied only when the old will be out of stock

Der neue Kode wird nur angegeben, wenn der alte nicht mehr lieferbar ist

Le nouveau code sera fourni uniquement lorsque le vieux stock sera écoulé

El nuevo código será suministrado sólo cuando se agoten las existencias del antiguo

O novo código irá ser fornecido apenas quando o antigo esgotar stock

easu MANIFOLD p. 247 p. 262

* F_{1i} = Isothermal end force at 100% Cu p. 16
 ** F_{1p} = Polytropic end force at 100% Cu

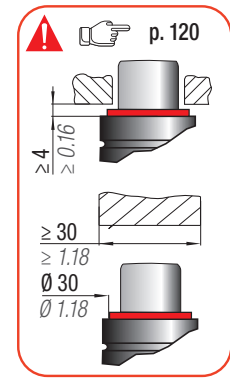
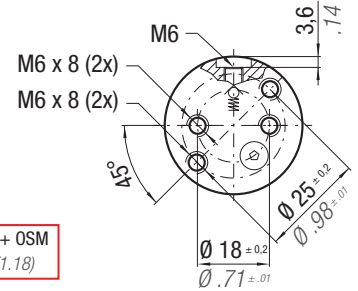
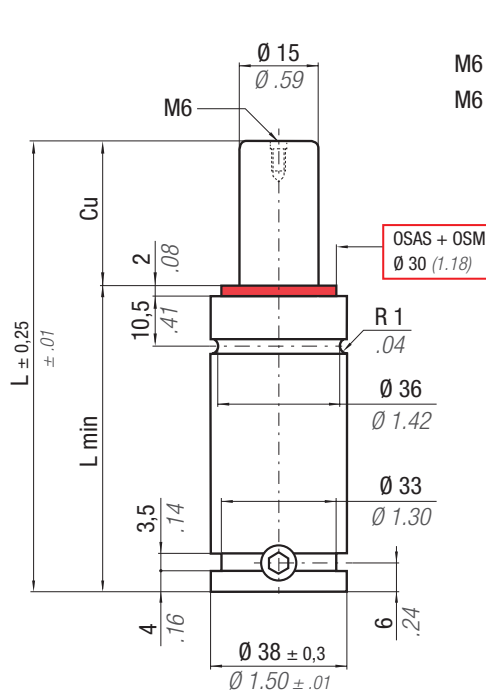

N ₂	0 - 80 °C 32 - 176 °F	ΔP ± 0,33 %/°C	P max 150 bar 2175 psi	P min 20 bar 290 psi	S 1,77 cm ² 0,274 in ²	SPM ~ 80 - 100 (at 20°C)	Max Speed 1,8 m/s 70,8 in/s	Maintenance kit 39BMS00250E
----------------	--------------------------	---------------------------	------------------------------	----------------------------	----------------------------------------------------	--------------------------------	-----------------------------------	--------------------------------

CODE PHASING OUT from 04/2021	NEW	Cu		L		L min		F ₀		F _{1i} *		F _{1p} **		V ₀		PED 2014/68/EU		
		mm	inch	mm	inch	mm	inch	daN	lb	daN	lb	daN	lb	cm ³	in ³		~Kg	~lb
SC 250 - 010 - D	♦ SC 250 - 010 - E	10	0.39	70	2.76	60	2.36	260 ± 5% 585 150 bar 2175 psi + 20 °C +68 °F		305	685	334	750	16,0	0,98	0,40	0,88	✓
SC 250 - 013 - D	♦ SC 250 - 013 - E	12,7	0,50	75,4	2,97	62,7	2,47			310	698	342	769	18,1	1,10	0,41	0,90	✓
SC 250 - 016 - D	SC 250 - 016 - E	16	0,63	82	3,23	66	2,60			316	711	350	788	20,6	1,26	0,43	0,95	✓
SC 250 - 019 - D	SC 250 - 019 - E	19	0,75	88	3,46	69	2,72			320	720	357	802	22,9	1,40	0,45	0,99	✓
SC 250 - 025 - D	SC 250 - 025 - E	25	0,98	100	3,94	75	2,95			327	734	366	823	27,4	1,67	0,48	1,06	✓
SC 250 - 038 - D	SC 250 - 038 - E	38	1,50	126	4,96	88	3,46			336	755	380	853	37,3	2,28	0,54	1,19	✓
SC 250 - 050 - D	SC 250 - 050 - E	50	1,97	150	5,91	100	3,94			341	766	387	870	46,5	2,84	0,60	1,32	✓
SC 250 - 063 - D	SC 250 - 063 - E	63,5	2,50	177	6,97	113,5	4,47			345	775	393	884	56,7	3,46	0,66	1,46	✓
SC 250 - 080 - D	SC 250 - 080 - E	80	3,15	210	8,27	130	5,12			348	782	398	894	69,3	4,23	0,74	1,63	✓
SC 250 - 100 - D	SC 250 - 100 - E	100	3,94	250	9,84	150	5,91			351	789	403	905	84,2	5,14	0,81	1,79	✓
SC 250 - 125 - D	SC 250 - 125 - E	125	4,92	300	11,81	175	6,89	355	798	409	919	101,6	6,20	0,98	2,16	✓		

♦ Disposable

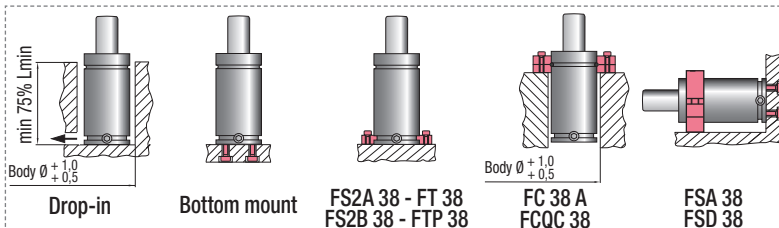

HOW TO ORDER

p. 121

INSTALLATION GUIDELINE

p. 205

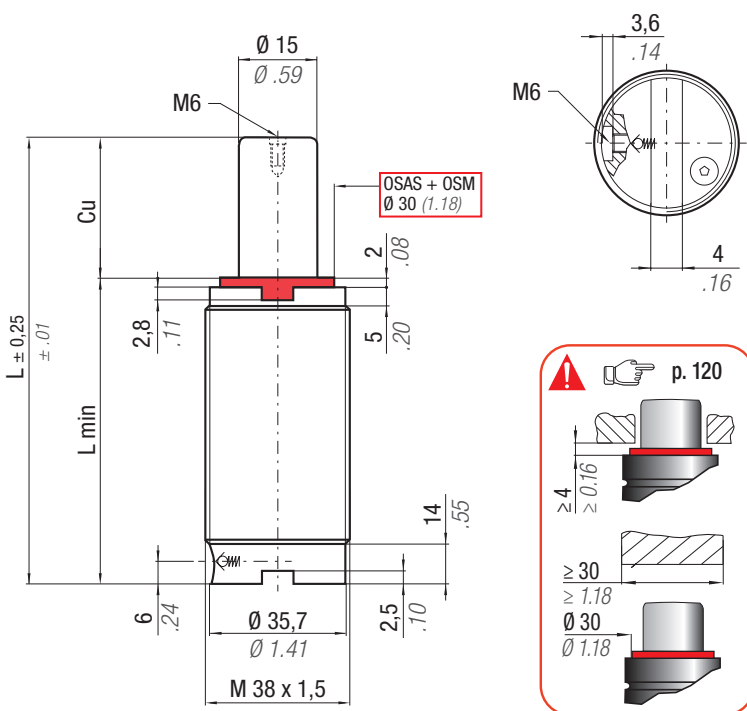

OSAS + OSM = OVER STROKE ACTIVE SAFETY + OVER STROKE MARKER



Il nuovo codice sarà fornito solo ad esaurimento del vecchio
 The new code will be supplied only when the old will be out of stock
 Der neue Kode wird nur angegeben, wenn der alte nicht mehr lieferbar ist
 Le nouveau code sera fourni uniquement lorsque le vieux stock sera écoulé
 El nuevo código será suministrado sólo cuando se agoten las existencias del antiguo
 O novo código irá ser fornecido apenas quando o antigo esgotar stock

ACTIVE SAFETY



OSAS



USAS



OPAS



* F_{1i} = Isothermal end force at 100% Cu p. 16
 ** F_{1p} = Polytrophic end force at 100% Cu

CODE PHASING OUT from 04/2021	NEW	ΔP		P_{max}	P_{min}	S	SPM	Max Speed	Maintenance kit								
		mm	inch	150 bar 2175 psi	20 bar 290 psi	1,77 cm ² 0.274 in ²	~ 80 - 100 (at 20°C)	1,8 m/s 70.8 in/s	39BMSC00250E								
SCF 250 - 010 - D	◆ SCF 250 - 010 - E	10	0.39	70	2.76	60	2.36	260 ± 5%	305	685	334	750	16,0	0.98	0,37	0.81	✓
SCF 250 - 013 - D	◆ SCF 250 - 013 - E	12,7	0.50	75,4	2.97	62,7	2.47		310	698	342	769	18,1	1.10	0,38	0.84	✓
SCF 250 - 016 - D	SCF 250 - 016 - E	16	0.63	82	3.23	66	2.60		316	711	350	788	20,6	1.26	0,39	0.86	✓
SCF 250 - 019 - D	SCF 250 - 019 - E	19	0.75	88	3.46	69	2.72		320	720	357	802	22,9	1.40	0,42	0.92	✓
SCF 250 - 025 - D	SCF 250 - 025 - E	25	0.98	100	3.94	75	2.95		327	734	366	823	27,4	1.67	0,44	0.97	✓
SCF 250 - 038 - D	SCF 250 - 038 - E	38	1.50	126	4.96	88	3.46		336	755	380	853	37,3	2.28	0,50	1.10	✓
SCF 250 - 050 - D	SCF 250 - 050 - E	50	1.97	150	5.91	100	3.94		341	766	387	870	46,5	2.84	0,55	1.21	✓
SCF 250 - 063 - D	SCF 250 - 063 - E	63,5	2.50	177	6.97	113,5	4.47		345	775	393	884	56,7	3.46	0,63	1.39	✓
SCF 250 - 080 - D	SCF 250 - 080 - E	80	3.15	210	8.27	130	5.12		348	782	398	894	69,3	4.23	0,70	1.54	✓
SCF 250 - 100 - D	SCF 250 - 100 - E	100	3.94	250	9.84	150	5.91		351	789	403	905	84,2	5.14	0,75	1.65	✓
SCF 250 - 125 - D	SCF 250 - 125 - E	125	4.92	300	11.81	175	6.89	355	798	409	919	101,6	6.20	0,93	2.05	✓	

◆ Disposable

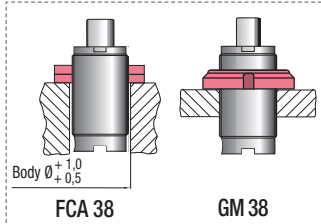
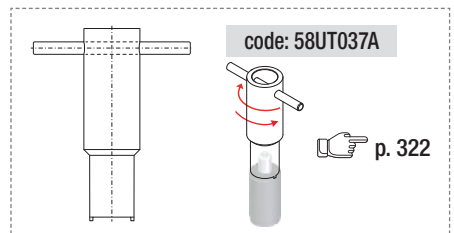

HOW TO ORDER

Hand icon p. 121

INSTALLATION GUIDELINE

Hand icon p. 205

ISO 11901 - 1	VDI 3003	B2 4006 (BMW)	075.90.55 (FCA)
PG23D (Mazda)	B8 3180 220 000 001(MB)	K 32 S (Nissan)	E24.54.815.G (PSA)
EM24.54.700 (Renault)	SES-K 5404e (Suzuki)	39D 878 (VW)	



OSAS + OSM = OVER STROKE ACTIVE SAFETY + OVER STROKE MARKER

ACTIVE SAFETY

Il nuovo codice sarà fornito solo ad esaurimento del vecchio

The new code will be supplied only when the old will be out of stock

Der neue Kode wird nur angegeben, wenn der alte nicht mehr lieferbar ist

Le nouveau code sera fourni uniquement lorsque le vieux stock sera écoulé

El nuevo código será suministrado sólo cuando se agoten las existencias del antiguo

O novo código irá ser fornecido apenas quando o antigo esgotar stock



OSAS



USAS



OPAS

easu MANIFOLD p. 247

p. 262

* F_{1i} =

Isothermal end force at 100% Cu



p. 16

** F_{1p} =

Polytropic end force at 100% Cu

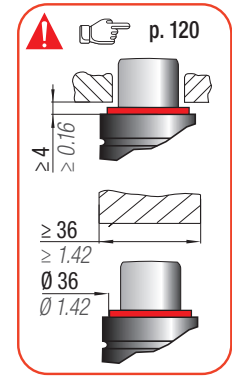
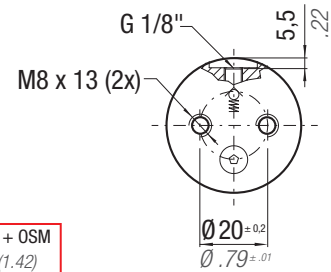
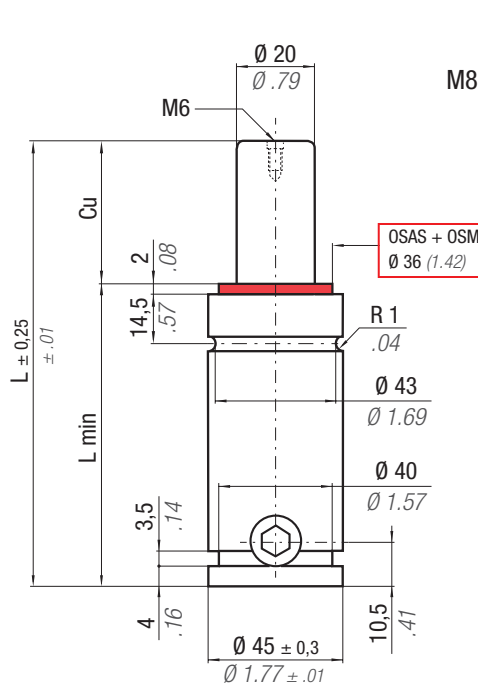

N ₂	0 - 80 °C 32 - 176 °F	ΔP ± 0,33 %/°C	P max 150 bar 2175 psi	P min 20 bar 290 psi	S 3,14 cm ² 0,487 in ²	SPM ~ 40 - 80 (at 20°C)	Max Speed 1,8 m/s 70,8 in/s	Maintenance kit 39BMS00500D
----------------	--------------------------	---------------------------	------------------------------	----------------------------	----------------------------------------------------	-------------------------------	-----------------------------------	--------------------------------

CODE PHASING OUT from 04/2021	NEW	Cu		L		L min		F ₀		F _{1i} *		F _{1p} **		V ₀		~Kg	~lb	PED 2014/68/EU
		mm	inch	mm	inch	mm	inch	daN	lb	daN	lb	daN	lb	cm ³	in ³			
SC 500 - 010 - D	♦ SC 500 - 010 - E	10	0.39	105	4.13	95	3.74	470 ± 5% 150 bar 2175 psi + 20 °C + 68 °F	1057	614	1381	701	1576	15,8	0,96	0,90	1,98	✓
SC 500 - 013 - D	♦ SC 500 - 013 - E	12,7	0,50	110,4	4,35	97,7	3,85			631	1418	727	1634	18,4	1,12	1,00	2,20	✓
-	■ SC 500 - 016 - E	16	0,63	117	4,61	101	3,98			647	1455	751	1688	21,5	1,31	1,00	2,20	✓
SC 500 - 025 - D	SC 500 - 025 - E	25	0,98	135	5,31	110	4,33			675	1516	794	1785	30,2	1,84	1,09	2,40	✓
SC 500 - 038 - D	SC 500 - 038 - E	38	1,50	161	6,34	123	4,84			696	1565	828	1862	42,7	2,61	1,20	2,65	✓
SC 500 - 050 - D	SC 500 - 050 - E	50	1,97	185	7,28	135	5,31			708	1591	847	1903	54,2	3,31	1,29	2,84	✓
SC 500 - 063 - D	SC 500 - 063 - E	63,5	2,50	212	8,35	148,5	5,85			716	1611	860	1934	67,2	4,10	1,38	3,04	✓
SC 500 - 080 - D	SC 500 - 080 - E	80	3,15	245	9,65	165	6,50			723	1626	871	1959	83,1	5,07	1,50	3,31	✓
SC 500 - 100 - D	SC 500 - 100 - E	100	3,94	285	11,22	185	7,28			729	1639	880	1979	102,3	6,24	1,64	3,62	✓
SC 500 - 125 - D	SC 500 - 125 - E	125	4,92	335	13,19	210	8,27			734	1649	888	1996	126,4	7,71	1,85	4,08	✓
SC 500 - 160 - D	SC 500 - 160 - E	160	6,30	405	15,94	245	9,65			738	1659	895	2011	160,1	9,77	2,10	4,63	✓
SC 500 - 200 - D	SC 500 - 200 - E	200	7,87	485	19,09	285	11,22			741	1666	900	2023	198,6	12,12	2,36	5,20	✓

♦ Disposable

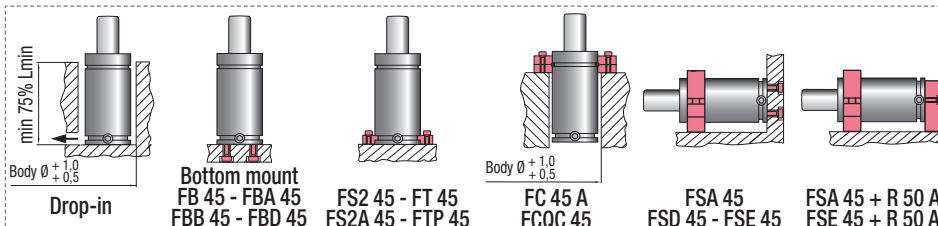

HOW TO ORDER

p. 121

INSTALLATION GUIDELINE

p. 205

ISO 11901 - 1	VDI 3003	B2 4006 (BMW)	075.90.55 (FCA)
W-DX35-6203 (Ford)	PG23D (Mazda)	B8 3180 220 000 001(MB)	K 32 S (Nissan)
E24.54.815.G (PSA)	EM24.54.700 (Renault)	SES-K 5404e (Suzuki)	39D 878 (VW)



ACTIVE SAFETY



OSAS



USAS



OPAS

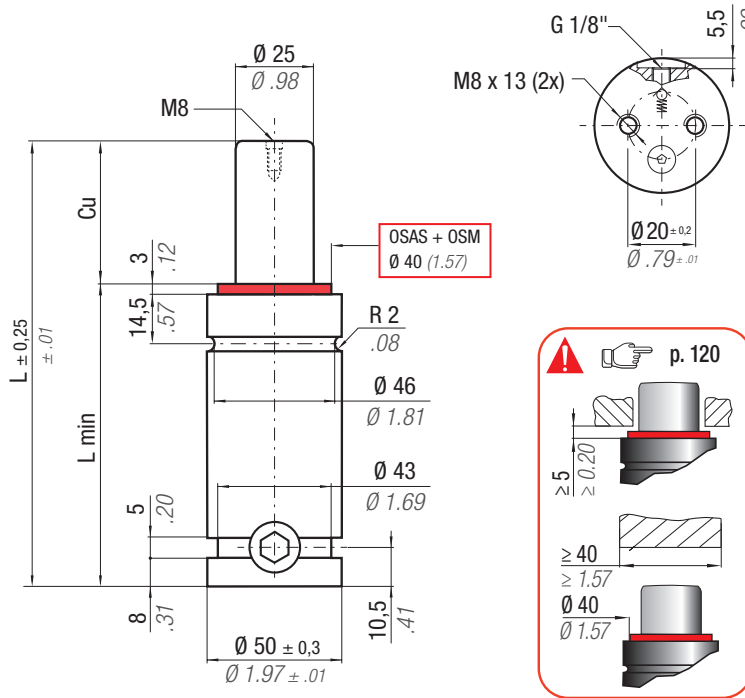

OSAS + OSM = OVER STROKE ACTIVE SAFETY + OVER STROKE MARKER

Il nuovo codice sarà fornito solo ad esaurimento del vecchio

The new code will be supplied only when the old will be out of stock

Der neue Kode wird nur angegeben, wenn der alte nicht mehr lieferbar ist

Le nouveau code sera fourni uniquement lorsque le vieux stock sera épuisé

El nuevo código será suministrado sólo cuando se agoten las existencias del antiguo

O novo código irá ser fornecido apenas quando o antigo esgotar stock

easu MANIPOL p. 247

p. 262

* $F_{1i} =$

Isothermal end force at 100% Cu

p. 16

** $F_{1p} =$

Polytrophic end force at 100% Cu

p. 16

	0 - 80 °C 32 - 176 °F	ΔP ± 0,33 %/°C	P max 150 bar 2175 psi	P min 20 bar 290 psi	S 4,91 cm ² 0.761 in ²	SPM ~ 15 - 50 (at 20°C)	Max Speed 1,8 m/s 70.8 in/s	Maintenance kit 39BMS00750D
--	--------------------------	---------------------------	-------------------------------------	-----------------------------------	-----------------------------------------------------------	--------------------------------------	------------------------------------------	---------------------------------------

CODE PHASING OUT from 04/2021	NEW	Cu		L		L min		F0 Initial force		F1i *		F1p **		V0		PED 2014/68/EU		
		mm	inch	mm	inch	mm	inch	daN	lb	daN	lb	daN	lb	cm ³	in ³	~Kg	~lb	✓
SC 750 - 013 - D	◆ SC 750 - 013 - E	12,7	0.50	120,4	4.74	107,7	4.24	740 ± 5%	1664	922	2073	1039	2335	36	2.21	1,24	2,73	✓
-	■ SC 750 - 016 - E	16	0.63	127	5.00	111	4.37			949	2133	1079	2426	41	2.50	1,28	2,81	✓
SC 750 - 025 - D	SC 750 - 025 - E	25	0.98	145	5.71	120	4.72			1002	2252	1160	2607	54	3.28	1,34	2,95	✓
SC 750 - 038 - D	SC 750 - 038 - E	38	1.50	171	6.73	133	5.24			1049	2359	1233	2772	73	4.42	1,45	3,20	✓
SC 750 - 050 - D	SC 750 - 050 - E	50	1.97	195	7.68	145	5.71			1077	2422	1277	2871	90	5.47	1,54	3,40	✓
SC 750 - 063 - D	SC 750 - 063 - E	63,5	2.50	222	8.74	158,5	6.24			1099	2471	1312	2949	109	6.65	1,65	3,64	✓
SC 750 - 075 - D	SC 750 - 075 - E	75	2.95	245	9.65	170	6.69			1113	2502	1334	2998	126	7.66	1,75	3,86	✓
SC 750 - 080 - D	SC 750 - 080 - E	80	3.15	255	10.04	175	6.89			1118	2513	1342	3016	133	8.10	1,79	3,95	✓
SC 750 - 088 - D	SC 750 - 088 - E	87,5	3.44	270	10.63	182,5	7.19			1128	2535	1357	3052	144	8.76	1,85	4.08	✓
SC 750 - 100 - D	SC 750 - 100 - E	100	3.94	295	11.61	195	7.68			1134	2549	1367	3073	161	9.85	1,96	4.32	✓
SC 750 - 113 - D	SC 750 - 113 - E	113	4.45	320	12.60	207	8.15	1144	2571	1383	3109	179	10.94	2,06	4.54	✓		
SC 750 - 125 - D	SC 750 - 125 - E	125	4.92	345	13.58	220	8.66	1147	2579	1389	3122	197	12.03	2,16	4.76	✓		
SC 750 - 138 - D	SC 750 - 138 - E	138	5.43	370	14.57	232	9.13	1158	2604	1407	3162	214	13.05	2,27	5.00	✓		
SC 750 - 150 - D	SC 750 - 150 - E	150	5.91	395	15.55	245	9.65	1168	2626	1423	3198	229	13.97	2,39	5.27	✓		
SC 750 - 160 - D	SC 750 - 160 - E	160	6.30	415	16.34	255	10.04	1177	2646	1437	3230	241	14.71	2,49	5.49	✓		
SC 750 - 175 - D	SC 750 - 175 - E	175	6.89	445	17.52	270	10.63	1189	2673	1456	3273	259	15.82	2,64	5.82	✓		
SC 750 - 200 - D	SC 750 - 200 - E	200	7.87	495	19.49	295	11.61	1206	2711	1483	3335	289	17.65	2,89	6.37	✓		
SC 750 - 225 - D	SC 750 - 225 - E	225	8.86	545	21.46	320	12.60	1220	2742	1506	3386	320	19.50	3,13	6.90	✓		
SC 750 - 250 - D	SC 750 - 250 - E	250	9.84	595	23.43	345	13.58	1232	2769	1526	3430	350	21.34	3,32	7.32	✓		
SC 750 - 275 - D	SC 750 - 275 - E	275	10.82	645	25.39	370	14.57	1242	2791	1542	3467	380	23.18	3,63	8.00	✓		
SC 750 - 300 - D	SC 750 - 300 - E	300	11.81	695	27.36	395	15.55	1250	2811	1557	3500	410	25.02	3,88	8.55	✓		

◆ Disposable

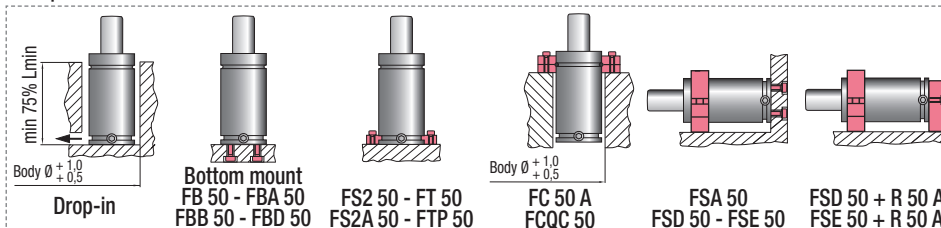

HOW TO ORDER

p. 121

INSTALLATION GUIDELINE

p. 205

ISO 11901 - 1	VDI 3003	B2 4006 (BMW)	075.90.55 (FCA)
W-DX35-6203 (Ford)	PG23D (Mazda)	B8 3180 220 000 001(MB)	K 32 S (Nissan)
E24.54.815.G (PSA)	EM24.54.700 (Renault)	SES-K 5404e (Suzuki)	39D 878 (VW)



OSAS + OSM = OVER STROKE ACTIVE SAFETY + OVER STROKE MARKER

ACTIVE SAFETY

Il nuovo codice sarà fornito solo ad esaurimento del vecchio

The new code will be supplied only when the old will be out of stock

Der neue Kode wird nur angegeben, wenn der alte nicht mehr lieferbar ist

Le nouveau code sera fourni uniquement lorsque le vieux stock sera écoulé

El nuevo código será suministrado sólo cuando se agoten las existencias del antiguo

O novo código irá ser fornecido apenas quando o antigo esgotar stock



OSAS



USAS



OPAS

easU MANIFOLD p. 247 p. 262

* F_{1i} = Isothermal end force at 100% Cu p. 16
 ** F_{1p} = Polytrophic end force at 100% Cu

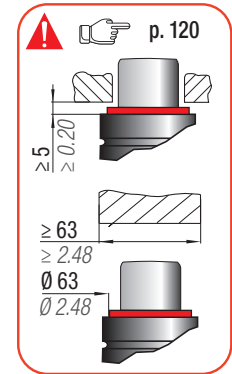
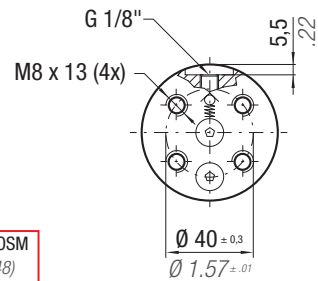
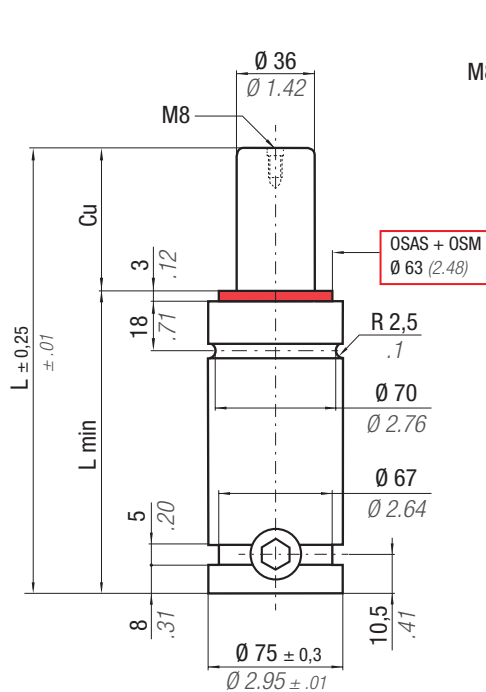

N ₂	0 - 80 °C 32 - 176 °F	ΔP ± 0,33 %/°C	P max 150 bar 2175 psi	P min 20 bar 290 psi	S 10,18 cm ² 1.578 in ²	SPM ~ 15 - 50 (at 20°C)	Max Speed 1,8 m/s 70.8 in/s	Maintenance kit 39BMSC01500DH
----------------	--------------------------	---------------------------	------------------------------	----------------------------	-----------------------------------------------------	-------------------------------	-----------------------------------	----------------------------------

CODE PHASING OUT from 04/2021	NEW	Cu		L		L min		F ₀		F _{1i} *		F _{1p} **		V ₀		PED 2014/68/EU		
		mm	inch	mm	inch	mm	inch	daN	lb	daN	lb	daN	lb	cm ³	in ³		~Kg	~lb
SC 1500 - 013 - D	♦ SC 1500 - 013 - E	13	0.51	135	5.31	122	4.80	1530 ± 5% 150 bar 2175 psi + 20 °C +68 °F	3440	1831	4116	2034	4573	93	5.70	3,26	7.19	✓
-	■ SC 1500 - 016 - E	16	0.63	142	5.59	126	4.96			1863	4188	2080	4676	106	6.47	3,29	7.25	✓
SC 1500 - 025 - D	SC 1500 - 025 - E	25	0.98	160	6.30	135	5.31			1949	4382	2210	4969	137	8.37	3,47	7.65	✓
SC 1500 - 038 - D	SC 1500 - 038 - E	38	1.50	186	7.32	148	5.83			2026	4555	2327	5231	183	11.16	3,67	8.09	✓
SC 1500 - 050 - D	SC 1500 - 050 - E	50	1.97	210	8.27	160	6.30			2072	4658	2397	5388	225	13.72	3,85	8.49	✓
SC 1500 - 063 - D	SC 1500 - 063 - E	63,5	2.50	237	9.33	173,5	6.83			2108	4739	2452	5513	272	16.62	4,05	8.93	✓
SC 1500 - 075 - D	SC 1500 - 075 - E	75	2.95	260	10.24	185	7.28			2130	4789	2487	5591	313	19.08	4,23	9.33	✓
SC 1500 - 080 - D	SC 1500 - 080 - E	80	3.15	270	10.63	190	7.48			2139	4808	2500	5620	330	20.15	4,30	9.48	✓
SC 1500 - 088 - D	SC 1500 - 088 - E	87,5	3.44	285	11.22	197,5	7.78			2157	4849	2528	5683	356	21.69	4,42	9.74	✓
SC 1500 - 100 - D	SC 1500 - 100 - E	100	3.94	310	12.20	210	8.27			2165	4866	2540	5711	400	24.43	4,60	10.14	✓
SC 1500 - 113 - D	SC 1500 - 113 - E	113	4.45	335	13.19	222	8.74			2181	4903	2566	5768	444	27.11	4,78	10.54	✓
SC 1500 - 125 - D	SC 1500 - 125 - E	125	4.92	360	14.17	235	9.25			2187	4917	2575	5789	488	29.79	4,97	10.96	✓
SC 1500 - 138 - D	SC 1500 - 138 - E	137,5	5.41	385	15.16	247,5	9.74			2199	4943	2594	5831	532	32.47	5,16	11.38	✓
SC 1500 - 150 - D	SC 1500 - 150 - E	150	5.91	410	16.14	260	10.24			2203	4952	2600	5844	576	35.15	5,35	11.79	✓
SC 1500 - 160 - D	SC 1500 - 160 - E	160	6.30	430	16.93	270	10.63			2208	4963	2608	5862	611	37.29	5,50	12.13	✓
SC 1500 - 175 - D	SC 1500 - 175 - E	175	6.89	460	18.11	285	11.22			2215	4978	2618	5886	664	40.51	5,73	12.63	✓
SC 1500 - 200 - D	SC 1500 - 200 - E	200	7.87	510	20.08	310	12.20			2228	5008	2639	5933	748	45.66	6,13	13.51	✓
SC 1500 - 225 - D	SC 1500 - 225 - E	225	8.86	560	22.05	335	13.19			2250	5058	2674	6011	824	50.27	6,60	14.55	✓
SC 1500 - 250 - D	SC 1500 - 250 - E	250	9.84	610	24.02	360	14.17			2268	5099	2703	6077	899	54.88	7,08	15.61	✓
SC 1500 - 275 - D	SC 1500 - 275 - E	275	10.83	660	22.05	385	15.16			2284	5135	2728	6133	975	59.48	7,55	16.64	✓
SC 1500 - 300 - D	SC 1500 - 300 - E	300	11.81	710	27.95	410	16.14			2298	5166	2750	6182	1050	64.09	8,02	17.68	✓

♦ Disposable

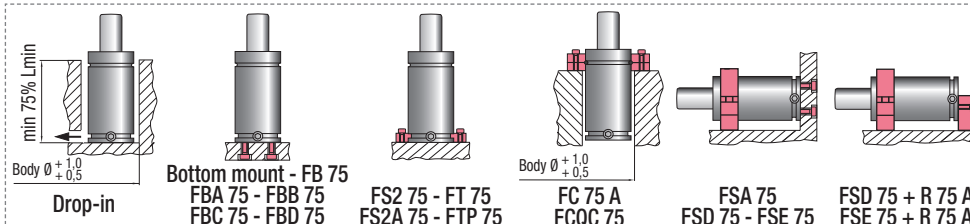

HOW TO ORDER

p. 121

INSTALLATION GUIDELINE

p. 205

ISO 11901 - 1	VDI 3003	B2 4006 (BMW)	075.90.55 (FCA)
W-DX35-6203 (Ford)	PG23D (Mazda)	B8 3180 220 000 001(MB)	K 32 S (Nissan)
E24.54.815.G (PSA)	EM24.54.700 (Renault)	SES-K 5404e (Suzuki)	39D 878 (VW)



ACTIVE SAFETY



OSAS



USAS



OPAS

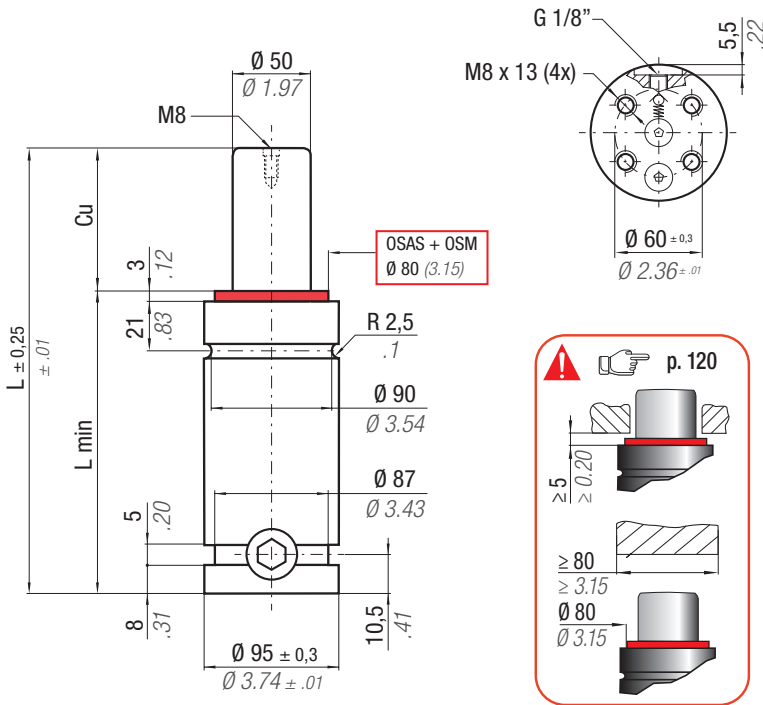

OSAS + OSM = OVER STROKE ACTIVE SAFETY + OVER STROKE MARKER

Il nuovo codice sarà fornito solo ad esaurimento del vecchio

The new code will be supplied only when the old will be out of stock

Der neue Kode wird nur angegeben, wenn der alte nicht mehr lieferbar ist

Le nouveau code sera fourni uniquement lorsque le vieux stock sera épuisé

El nuevo código será suministrado sólo cuando se agoten las existencias del antiguo

O novo código irá ser fornecido apenas quando o antigo esgotar stock

easu MANIPOL p. 247

p. 262

* $F_{1i} =$

Isothermal end force at 100% Cu

p. 16

** $F_{1p} =$

Polytrophic end force at 100% Cu

	0 - 80 °C 32 - 176 °F	ΔP ± 0,33 %/°C	P max 150 bar 2175 psi	P min 20 bar 290 psi	S 19,63 cm ² 3.043 in ²	SPM ~ 15 - 50 (at 20°C)	Max Speed 1,8 m/s 70.8 in/s	Maintenance kit 39BMSOC3000E
--	--------------------------	---------------------------	-------------------------------------	-----------------------------------	------------------------------------------------------------	--------------------------------------	------------------------------------------	----------------------------------------

CODE PHASING OUT from 04/2021	NEW	Cu		L		L min		F0 Initial force		F1i * End force *		F1p ** End force **		V0		PED 2014/68/EU		
		mm	inch	mm	inch	mm	inch	daN	lb	daN	lb	daN	lb	cm ³	in ³	~Kg	~lb	✓
SC 3000 - 013 - D	SC 3000 - 013 - E	13	0.51	145	5.71	132	5.20	2945	6621	3532	7940	3923	8820	180	11.00	5,57	12.28	✓
SC 3000 - 025 - D	SC 3000 - 025 - E	25	0.98	170	6.69	145	5.71			3802	8547	4327	9726	254	15.51	5,90	13.01	✓
SC 3000 - 038 - D	SC 3000 - 038 - E	38	1.50	196	7.72	158	6.22			3988	8964	4609	10362	332	20.25	6,21	13.69	✓
SC 3000 - 050 - D	SC 3000 - 050 - E	50	1.97	220	8.66	170	6.69			4103	9225	4788	10764	404	24.64	6,50	14.33	✓
SC 3000 - 063 - D	SC 3000 - 063 - E	63,5	2.50	247	9.72	183,5	7.22			4197	9435	4934	11091	484	29.55	6,83	15.06	✓
SC 3000 - 075 - D	SC 3000 - 075 - E	75	2.95	270	10.63	195	7.68			4257	9571	5028	11303	553	33.75	7,10	15.65	✓
SC 3000 - 080 - D	SC 3000 - 080 - E	80	3.15	280	11.02	200	7.87			4279	9620	5062	11381	583	35.58	7,22	15.92	✓
SC 3000 - 088 - D	SC 3000 - 088 - E	87,5	3.44	295	11.61	207,5	8.17			4320	9712	5126	11525	628	38.31	7,41	16.34	✓
SC 3000 - 100 - D	SC 3000 - 100 - E	100	3.94	320	12.60	220	8.66			4350	9780	5175	11633	703	42.87	7,67	16.91	✓
SC 3000 - 113 - D	SC 3000 - 113 - E	113	4.45	345	13.58	232	9.13			4394	9878	5243	11787	777	47.43	7,97	17.57	✓
SC 3000 - 125 - D	SC 3000 - 125 - E	125	4.92	370	14.57	245	9.65	4412	9917	5271	11850	853	52.02	8,27	18.23	✓		
SC 3000 - 138 - D	SC 3000 - 138 - E	138	5.43	395	15.55	257	10.12	4444	9990	5322	11965	927	56.59	8,57	18.89	✓		
SC 3000 - 150 - D	SC 3000 - 150 - E	150	5.91	420	16.54	270	10.63	4457	10019	5343	12011	1002	61.15	8,87	19.56	✓		
SC 3000 - 160 - D	SC 3000 - 160 - E	160	6.30	440	17.32	280	11.02	4471	10052	5366	12064	1062	64.79	9,11	20.08	✓		
SC 3000 - 175 - D	SC 3000 - 175 - E	175	6.89	470	18.50	295	11.61	4491	10095	5397	12133	1151	70.26	9,47	20.88	✓		
SC 3000 - 200 - D	SC 3000 - 200 - E	200	7.87	520	20.47	320	12.60	4517	10155	5439	12228	1301	79.38	10,08	22.22	✓		
SC 3000 - 225 - D	SC 3000 - 225 - E	225	8.86	570	22.44	345	13.58	4538	10202	5473	12304	1450	88.50	10,68	23.55	✓		
SC 3000 - 250 - D	SC 3000 - 250 - E	250	9.84	620	24.41	370	14.57	4556	10241	5501	12367	1600	97.62	11,28	24.87	✓		
SC 3000 - 275 - D	SC 3000 - 275 - E	275	10.83	670	26.38	395	15.55	4570	10274	5524	12419	1749	106.74	11,88	26.19	✓		
SC 3000 - 300 - D	SC 3000 - 300 - E	300	11.81	720	28.35	420	16.54	4582	10302	5544	12463	1899	115.85	12,49	27.54	✓		

◆ Disposable

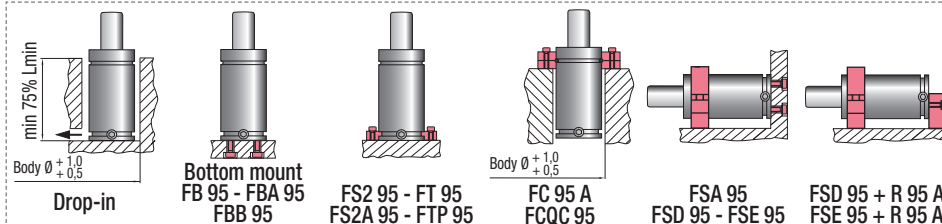

HOW TO ORDER

p. 121

INSTALLATION GUIDELINE

p. 205

SC 5000

ISO 11901 - 1	VDI 3003	B2 4006 (BMW)	075.90.55 (FCA)
W-DX35-6203 (Ford)	PG23D (Mazda)	B8 3180 220 000 001(MB)	K 32 S (Nissan)
E24.54.815.G (PSA)	EM24.54.700 (Renault)	SES-K 5404e (Suzuki)	39D 878 (VW)



OSAS + OSM = OVER STROKE ACTIVE SAFETY + OVER STROKE MARKER

ACTIVE SAFETY

Il nuovo codice sarà fornito solo ad esaurimento del vecchio

The new code will be supplied only when the old will be out of stock

Der neue Kode wird nur angegeben, wenn der alte nicht mehr lieferbar ist

Le nouveau code sera fourni uniquement lorsque le vieux stock sera écoulé

El nuevo código será suministrado sólo cuando se agoten las existencias del antiguo

O novo código irá ser fornecido apenas quando o antigo esgotar stock



easU MANIFOLD p. 247 p. 262

* F_{1i} = Isothermal end force at 100% Cu p. 16
 ** F_{1p} = Polytrophic end force at 100% Cu

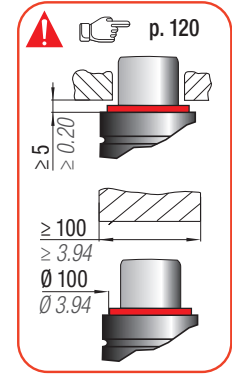
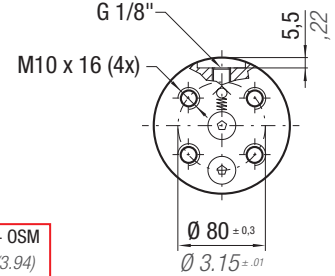
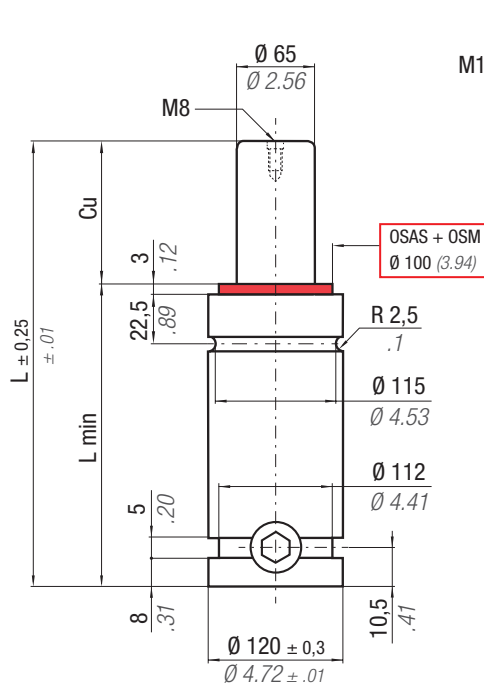

N ₂	0 - 80 °C 32 - 176 °F	ΔP ± 0,33 %/°C	P max 150 bar 2175 psi	P min 20 bar 290 psi	S 33,18 cm ² 5.143 in ²	SPM ~ 15 - 50 (at 20°C)	Max Speed 1,8 m/s 70.8 in/s	Maintenance kit 39BMS05000E
----------------	--------------------------	---------------------------	-------------------------------------	-----------------------------------	------------------------------------------------------------	--------------------------------------	------------------------------------------	---------------------------------------

CODE PHASING OUT from 04/2021	NEW	Cu		L		L min		F ₀		F _{1i} *		F _{1p} **		V ₀		PED 2014/68/EU		
		mm	inch	mm	inch	mm	inch	daN	lb	daN	lb	daN	lb	cm ³	in ³		~Kg	~lb
SC 5000 - 025 - D	SC 5000 - 025 - E	25	0.98	190	7.48	165	6.50	4980 ± 5%	11195	6344	14261	7189	16161	450	27.46	10,94	24.12	✓
SC 5000 - 038 - D	SC 5000 - 038 - E	38	1.50	216	8.50	178	7.01			6688	15036	7712	17338	574	35.00	11,46	25.26	✓
SC 5000 - 050 - D	SC 5000 - 050 - E	50	1.97	240	9.45	190	7.48			6914	15543	8059	18118	688	41.96	11,94	26.32	✓
SC 5000 - 063 - D	SC 5000 - 063 - E	63,5	2.50	267	10.51	203,5	8.01			7102	15966	8352	18776	816	49.80	12,56	27.69	✓
SC 5000 - 075 - D	SC 5000 - 075 - E	75	2.95	290	11.42	215	8.46			7226	16245	8547	19213	925	56.47	12,94	28.53	✓
SC 5000 - 080 - D	SC 5000 - 080 - E	80	3.15	300	11.81	220	8.66			7273	16349	8619	19377	973	59.37	13,15	28.99	✓
SC 5000 - 088 - D	SC 5000 - 088 - E	87,5	3.44	315	12.40	227,5	8.96			7354	16533	8748	19666	1044	63.72	13,39	29.52	✓
SC 5000 - 100 - D	SC 5000 - 100 - E	100	3.94	340	13.39	240	9.45			7424	16689	8858	19913	1163	70.97	13,89	30.62	✓
SC 5000 - 113 - D	SC 5000 - 113 - E	113	4.45	365	14.37	252	9.92			7514	16891	9001	20234	1282	78.22	14,40	31.75	✓
SC 5000 - 125 - D	SC 5000 - 125 - E	125	4.92	390	15.35	265	10.43			7560	16994	9074	20398	1401	85.48	14,90	32.85	✓
SC 5000 - 138 - D	SC 5000 - 138 - E	138	5.43	415	16.34	277	10.91			7627	17146	9181	20640	1520	92.73	15,40	33.95	✓
SC 5000 - 150 - D	SC 5000 - 150 - E	150	5.91	440	17.32	290	11.42			7659	17218	9232	20755	1638	99.98	15,90	35.05	✓
SC 5000 - 160 - D	SC 5000 - 160 - E	160	6.30	460	18.11	300	11.81			7691	17291	9284	20872	1733	105.78	16,30	35.94	✓
SC 5000 - 175 - D	SC 5000 - 175 - E	175	6.89	490	19.29	315	12.40			7750	17424	9379	21085	1869	114.04	16,90	37.26	✓
SC 5000 - 200 - D	SC 5000 - 200 - E	200	7.87	540	21.26	340	13.39			7809	17555	9473	21296	2107	128.55	17,91	39.48	✓
SC 5000 - 225 - D	SC 5000 - 225 - E	225	8.86	590	23.23	365	14.37			7856	17660	9549	21466	2344	143.05	18,91	41.69	✓
SC 5000 - 250 - D	SC 5000 - 250 - E	250	9.84	640	25.20	390	15.35			7894	17747	9611	21607	2582	157.56	19,91	43.89	✓
SC 5000 - 275 - D	SC 5000 - 275 - E	275	10.83	690	27.17	415	16.34			7927	17820	9664	21725	2820	172.06	20,92	46.12	✓
SC 5000 - 300 - D	SC 5000 - 300 - E	300	11.81	740	29.13	440	17.32			7954	17882	9708	21825	3057	186.56	21,92	48.33	✓

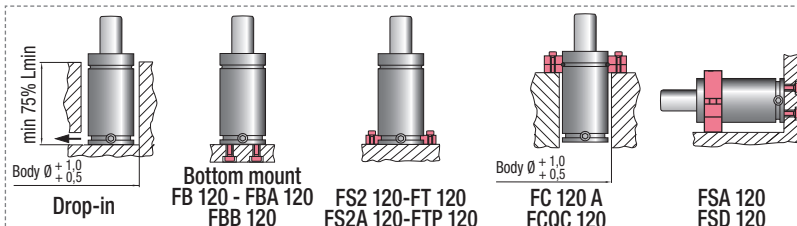

HOW TO ORDER p. 121

INSTALLATION GUIDELINE p. 205

ISO 11901 - 1	VDI 3003	B2 4006 (BMW)	075.90.55 (FCA)
W-DX35-6203 (Ford)	PG23D (Mazda)	B8 3180 220 000 001(MB)	E24.54.815.G (PSA)
EM24.54.700 (Renault)	39D 878 (VW)		

SC 7500



ACTIVE SAFETY

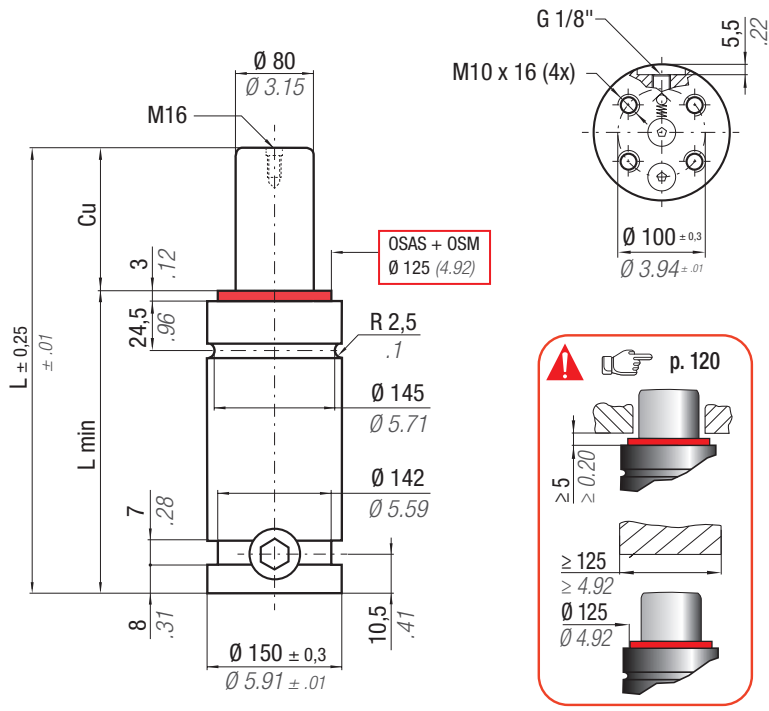

OSAS + OSM = OVER STROKE ACTIVE SAFETY + OVER STROKE MARKER

Il nuovo codice sarà fornito solo ad esaurimento del vecchio
 The new code will be supplied only when the old will be out of stock
 Der neue Kode wird nur angegeben, wenn der alte nicht mehr lieferbar ist
 Le nouveau code sera fourni uniquement lorsque le vieux stock sera épuisé
 El nuevo código será suministrado sólo cuando se agoten las existencias del antiguo
 O novo código irá ser fornecido apenas quando o antigo esgotar stock

easu MANIPOL p. 247 p. 262

* F_{1i} = Isothermal end force at 100% Cu p. 16
 ** F_{1p} = Polytrophic end force at 100% Cu

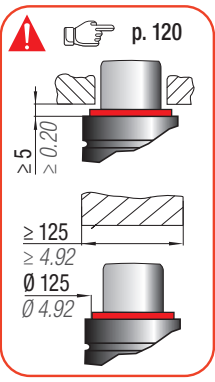

N ₂	0 - 80 °C 32 - 176 °F	ΔP ± 0,33 %/°C	P max 150 bar 2175 psi	P min 20 bar 290 psi	S 50,27 cm ² 7.792 in ²	SPM ~ 15 - 50 (at 20°C)	Max Speed 1,8 m/s 70.8 in/s	Maintenance kit 39BMSC07500DH
----------------	--------------------------	---------------------------	-------------------------------------	-----------------------------------	------------------------------------------------------------	--------------------------------------	------------------------------------------	-----------------------------------------

CODE PHASING OUT from 04/2021	NEW	Cu		L		L min		F ₀ Initial force		F _{1i} * End force *		F _{1p} ** End force **		V ₀		PED 2014/68/EU		
		mm	inch	mm	inch	mm	inch	daN	lb	daN	lb	daN	lb	cm ³	in ³		~Kg	~lb
SC 7500 - 025 - D	SC 7500 - 025 - E	25	0.98	205	8.07	180	7.09	7540 ± 5%	16950	9357	21035	10511	23630	757	46.22	18,71	41.25	✓
SC 7500 - 038 - D	SC 7500 - 038 - E	38	1.50	231	9.09	193	7.60			9845	22132	11246	25282	951	58.05	19,50	42.99	✓
SC 7500 - 050 - D	SC 7500 - 050 - E	50	1.97	255	10.04	205	8.07			10171	22866	11743	26400	1130	68.96	20,24	44.62	✓
SC 7500 - 063 - D	SC 7500 - 063 - E	63,5	2.50	282	11.10	218,5	8.60			10448	23488	12170	27359	1331	81.23	21,06	46.43	✓
SC 7500 - 075 - D	SC 7500 - 075 - E	75	2.95	305	12.10	230	9.06			10633	23904	12456	28003	1503	91.69	21,76	47.97	✓
SC 7500 - 080 - D	SC 7500 - 080 - E	80	3.15	315	12.40	235	9.25			10702	24060	12564	28246	1577	96.24	22,07	48.66	✓
SC 7500 - 088 - D	SC 7500 - 088 - E	87,5	3.44	330	12.99	242,5	9.55			10822	24329	12751	28666	1689	103.06	22,45	49.49	✓
SC 7500 - 100 - D	SC 7500 - 100 - E	100	3.94	355	13.98	255	10.04			10930	24572	12921	29047	1875	114.43	23,23	51.21	✓
SC 7500 - 113 - D	SC 7500 - 113 - E	113	4.45	380	14.96	267	10.51			11076	24900	13150	29562	2057	125.52	23,98	52.87	✓
SC 7500 - 125 - D	SC 7500 - 125 - E	125	4.92	405	15.94	280	11.02			11138	25039	13248	29782	2248	137.17	24,76	54.59	✓
SC 7500 - 138 - D	SC 7500 - 138 - E	138	5.43	430	16.93	292	11.50	11249	25289	13424	30177	2430	148.26	25,51	56.24	✓		
SC 7500 - 150 - D	SC 7500 - 150 - E	150	5.91	455	17.91	305	12.10	11291	25382	13490	30326	2620	159.91	26,28	57.94	✓		
SC 7500 - 160 - D	SC 7500 - 160 - E	160	6.30	475	18.70	315	12.40	11341	25496	13570	30506	2769	169.00	26,90	59.30	✓		
SC 7500 - 175 - D	SC 7500 - 175 - E	175	6.89	505	19.88	330	12.99	11408	25646	13676	30745	2993	182.64	27,81	61.31	✓		
SC 7500 - 200 - D	SC 7500 - 200 - E	200	7.87	555	21.85	355	13.98	11501	25856	13824	31079	3366	205.38	29,34	64.68	✓		
SC 7500 - 225 - D	SC 7500 - 225 - E	225	8.86	605	23.82	380	14.96	11577	26025	13945	31350	3738	228.12	30,87	68.06	✓		
SC 7500 - 250 - D	SC 7500 - 250 - E	250	9.84	655	25.79	405	15.94	11639	26166	14045	31574	4111	250.85	32,39	71.41	✓		
SC 7500 - 275 - D	SC 7500 - 275 - E	275	10.83	705	27.76	430	16.93	11692	26284	14129	31764	4483	273.59	33,92	74.78	✓		
SC 7500 - 300 - D	SC 7500 - 300 - E	300	11.81	755	29.72	455	17.91	11736	26385	14201	31926	4856	296.33	35,45	78.15	✓		

SC
SCF

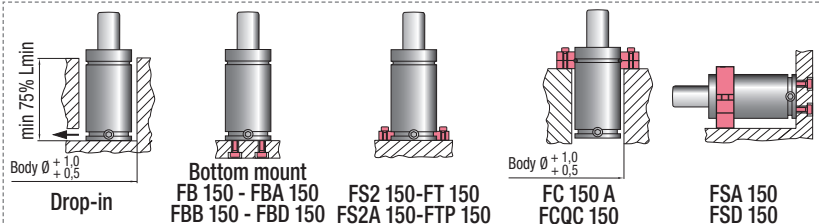

HOW TO ORDER

p. 121

INSTALLATION GUIDELINE

p. 205



OSAS + OSM = OVER STROKE ACTIVE SAFETY + OVER STROKE MARKER

ACTIVE SAFETY

Il nuovo codice sarà fornito solo ad esaurimento del vecchio

The new code will be supplied only when the old will be out of stock

Der neue Kode wird nur angegeben, wenn der alte nicht mehr lieferbar ist

Le nouveau code sera fourni uniquement lorsque le vieux stock sera écoulé

El nuevo código será suministrado sólo cuando se agoten las existencias del antiguo

O novo código irá ser fornecido apenas quando o antigo esgotar stock



OSAS



USAS



OPAS

easU MANIFOLD p. 247 p. 262

* F_{1i} = Isothermal end force at 100% Cu p. 16
 ** F_{1p} = Polytropic end force at 100% Cu

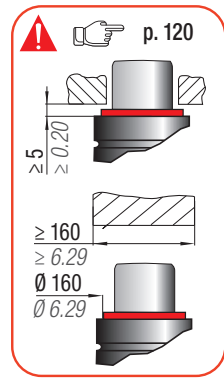
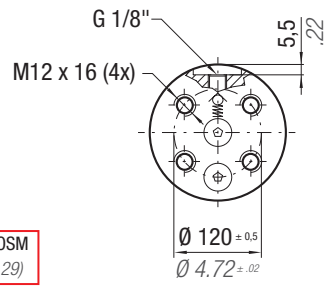
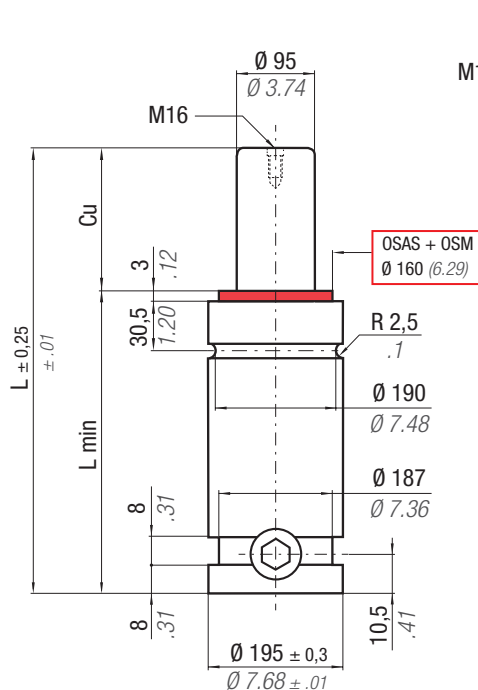

N₂	0 - 80 °C 32 - 176 °F	ΔP ± 0,33 %/°C	P max 150 bar 2175 psi	P min 20 bar 290 psi	S 70,88 cm ² 10.986 in ²	SPM ~ 15 - 50 (at 20°C)	Max Speed 1,8 m/s 70.8 in/s	Maintenance kit 39BMSC10000D
----------------------	--------------------------	---------------------------	-------------------------------------	-----------------------------------	-------------------------------------------------------------	--------------------------------------	------------------------------------------	----------------------------------------

CODE PHASING OUT from 04/2021	NEW	Cu		L		L min		F ₀		F _{1i} *		F _{1p} **		V ₀		PED 2014/68/EU		
		mm	inch	mm	inch	mm	inch	daN	lb	daN	lb	daN	lb	cm ³	in ³		~Kg	~lb
SC 10000 - 025 - D	◆ SC 10000 - 025 - E	25	0.98	210	8.27	185	7.28	10600 ± 5%	23830	12918	29040	14411	32398	1174	71.65	33,73	74.36	✓
SC 10000 - 038 - D	SC 10000 - 038 - E	38	1.50	236	9.29	198	7.80			13498	30345	15277	34345	1482	90.45	35,08	77.34	✓
SC 10000 - 050 - D	SC 10000 - 050 - E	50	1.97	260	10.24	210	8.27			13879	31200	15852	35636	1767	107.81	36,32	80.07	✓
SC 10000 - 063 - D	SC 10000 - 063 - E	63,5	2.50	287	11.30	223,5	8.80			14197	31916	16336	36726	2087	127.34	37,72	83.16	✓
SC 10000 - 080 - D	SC 10000 - 080 - E	80	3.15	320	12.60	240	9.45			14486	32565	16779	37720	2478	151.20	39,44	86.95	✓
SC 10000 - 100 - D	SC 10000 - 100 - E	100	3.94	360	14.17	260	10.24			14742	33140	17174	38608	2952	180.14	41,51	91.51	✓
SC 10000 - 125 - D	SC 10000 - 125 - E	125	4.92	410	16.14	285	11.22			14972	33659	17531	39412	3545	216.30	44,11	97.25	✓
SC 10000 - 160 - D	SC 10000 - 160 - E	160	6.30	480	18.90	320	12.60			15196	34163	17881	40197	4374	266.92	47,74	105.25	✓
SC 10000 - 200 - D	SC 10000 - 200 - E	200	7.87	560	22.05	360	14.17			15415	34654	18222	40966	5288	322.68	52,17	115.02	✓
SC 10000 - 250 - D	SC 10000 - 250 - E	250	9.84	660	25.98	410	16.14			15774	35462	18789	42240	6281	383.26	58,87	129.79	✓
SC 10000 - 300 - D	SC 10000 - 300 - E	300	11.81	760	29.92	460	18.11	16046	36072	19219	43207	7273	443.84	65,57	144.56	✓		

◆ Disposable

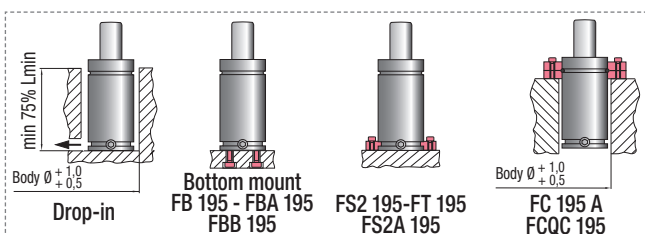

HOW TO ORDER p. 121

INSTALLATION GUIDELINE p. 205

THIS PAGE IS INTENTIONALLY LEFT BLANK

ISO	VDI	BMW
FCA	VW	

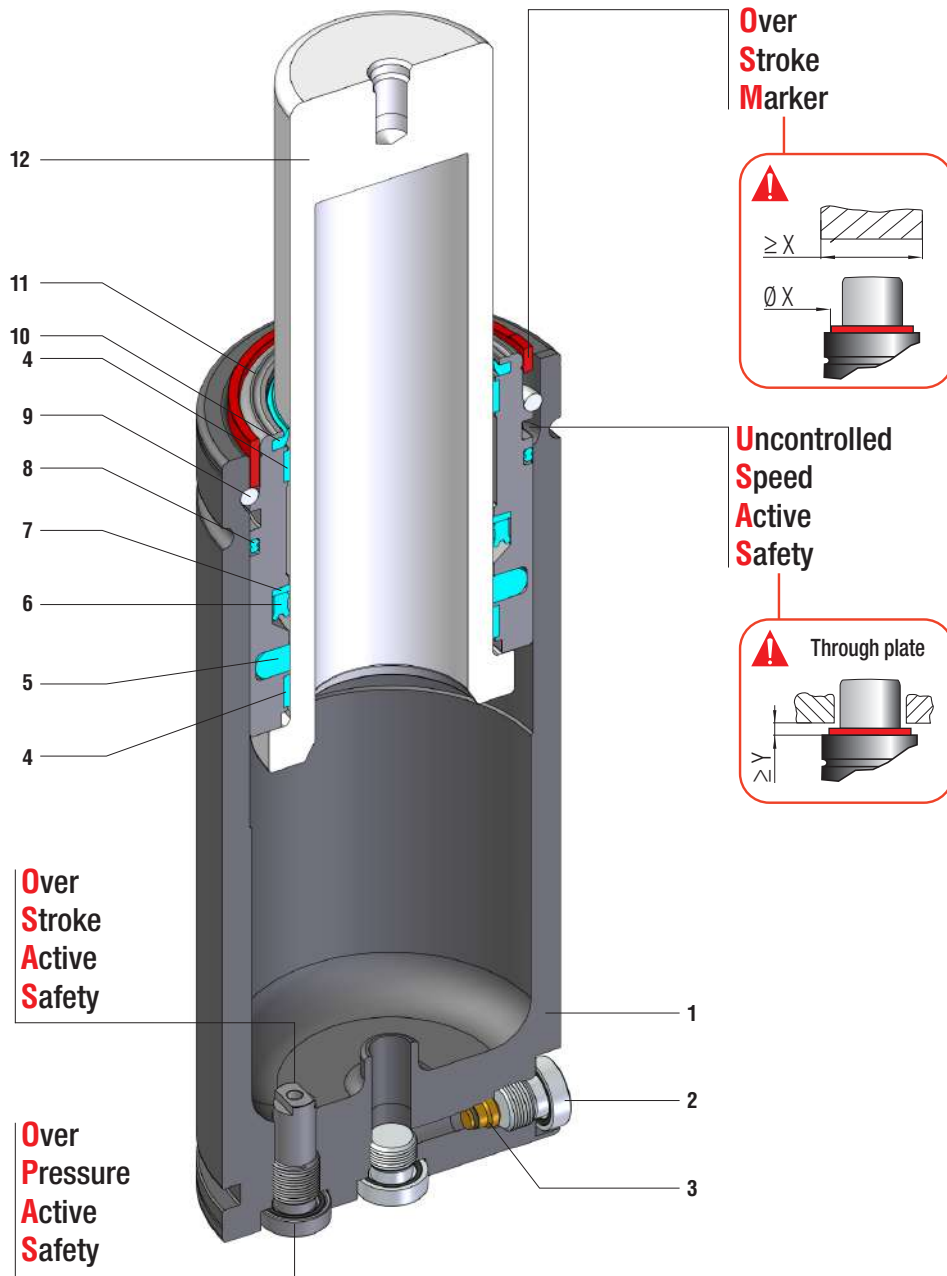

ISO standard, forza potenziata - ISO standard, high force - ISO Standard, erhöhte Kraft
 Standard ISO, force majorée - ISO standard, fuerza potenciada - Norma ISO, forța permitida

SEALING	ROD SEAL
DESIGN	BUSH - BODY DESIGN

1	Body	5	Rod seal	9	Retaining ring
2	Plug	6	Rod seal	10	Rod wiper
3	Valve	7	Back-up ring	11	Bush
4	Guide ring	8	Dual ring seal	12	Rod (nitrited superfinished)

RANGE CHART

Model	Body Ø		Stroke Cu		Initial force F0						
	mm	inch	mm	inch	daN	lb	OSAS	USAS	OPAS	SKUDO	SW
H 300	32	1.26	10 - 125	0.39 - 4.92	300	674	✓	✓	✓	-	✓
H 500	38	1.50	10 - 125	0.39 - 4.92	470	1057	✓	✓	✓	-	✓
HF 500	M 38 X 1,5		10 - 125	0.39 - 4.92	470	1057	✓	✓	✓	-	✓
H 700	45	1.77	10 - 200	0.51 - 7.87	680	1529	✓	✓	✓	-	✓
H 1000	50	1.97	13 - 300	0.51 - 11.81	920	2383	✓	✓	✓	-	✓
H 1500	63	2.48	13 - 300	0.51 - 11.81	1530	3440	✓	✓	✓	-	✓
H 2400	75	2.95	25 - 300	0.98 - 11.81	2385	5362	✓	✓	✓	-	✓
H 4200	95	3.74	25 - 300	0.98 - 11.81	4240	9532	✓	✓	✓	-	✓
H 6600	120	4.72	25 - 300	0.98 - 11.81	6630	14905	✓	✓	✓	-	✓
H 9500	150	5.91	25 - 300	0.98 - 11.81	9540	21446	✓	✓	✓	-	✓
H 18500	195	7.68	25 - 300	0.98 - 11.81	18400	41365	✓	✓	✓	-	✓
H 20000	195	7.68	25 - 300	0.98 - 11.81	19910	44756	✓	✓	✓	-	✓

✓ Built-in as standard

✓ Optional upon request

HOW TO ORDER

Series _____ Revision code _____

Model **H 1000-050-E-E-W**

Stroke _____ Version _____

H
HF

Available versions

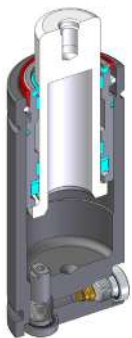

H 1000-050-E
Standard code



Self contained

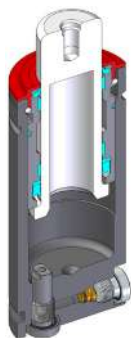

H 1000-050-E-W
Add "-W" to standard code



Self contained



+
Secondary wiper

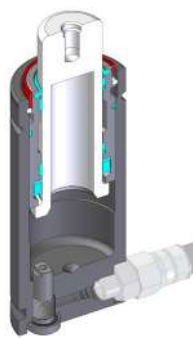

H 1000-050-E-N
Add "-N" to standard code



Linkable

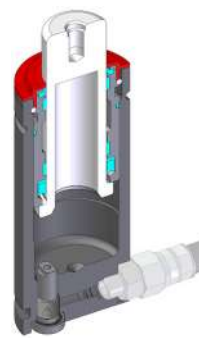

H 1000-050-E-N-W
Add "-N-W" to standard code



Linkable



+
Secondary wiper

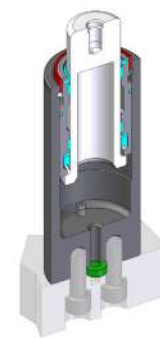

H 1000-050-E-E
Add "-E" to standard code



Easy
Manifold

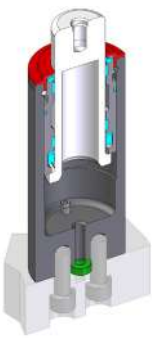

H 1000-050-E-E-W
Add "-E-W" to standard code



Easy
Manifold



+
Secondary wiper



OSAS + OSM = OVER STROKE ACTIVE SAFETY + OVER STROKE MARKER

ACTIVE SAFETY



OSAS



USAS



OPAS

Il nuovo codice sarà fornito solo ad esaurimento del vecchio
 The new code will be supplied only when the old will be out of stock
 Der neue Kode wird nur angegeben, wenn der alte nicht mehr lieferbar ist
 Le nouveau code sera fourni uniquement lorsque le vieux stock sera écoulé
 El nuevo código será suministrado sólo cuando se agoten las existencias del antiguo
 O novo código irá ser fornecido apenas quando o antigo esgotar stock

easU MANIFOLD p. 247

p. 262

* F_{1i} = Isothermal end force at 100% Cu p. 16

** F_{1p} = Polytrophic end force at 100% Cu

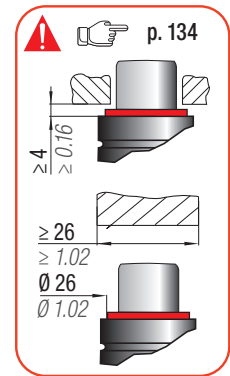
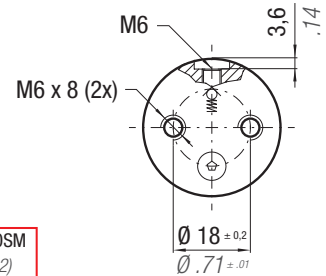
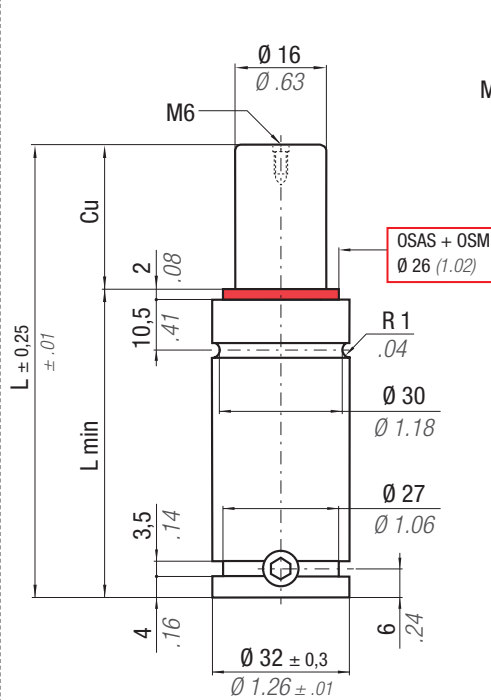

N ₂		0 - 80 °C 32 - 176 °F	ΔP ± 0,33 %/°C	P max 150 bar 2175 psi	P min 20 bar 290 psi	S 2,01 cm ² 0,312 in ²	SPM ~ 30 - 100 (at 20°C)	Max Speed 1,8 m/s 70,8 in/s	Maintenance kit 39BMH00300C	
CODE PHASING OUT from 04/2021	NEW	Cu	L	L min	F ₀	F _{1i} *	F _{1p} **	V ₀		PED 2014/68/EU
H 300 - 010 - C	◆ H 300 - 010 - D	10 0.39	70 2.76	60 2.36	300 674 ± 5% 150 bar 2175 psi + 20 °C +68 °F	372 837	418 939	12,4 0.76	0,22 0.49	✓
H 300 - 013 - C	H 300 - 013 - D	13 0.51	75,7 2.98	62,7 2.47		386 867	437 983	14,0 0.85	0,23 0.51	✓
H 300 - 016 - C	H 300 - 016 - D	16 0.63	82 3.23	66 2.60		394 887	451 1013	16,0 0.98	0,24 0.53	✓
H 300 - 025 - C	H 300 - 025 - D	25 0.98	100 3.94	75 2.95		416 934	483 1086	21,3 1.30	0,26 0.57	✓
H 300 - 038 - C	H 300 - 038 - D	38 1.50	126 4.96	88 3.46		434 976	512 1150	29,0 1.77	0,31 0.68	✓
H 300 - 050 - C	H 300 - 050 - D	50 1.97	150 5.91	100 3.94		445 999	528 1188	36,1 2.20	0,35 0.77	✓
H 300 - 063 - C	H 300 - 063 - D	63 2.48	176,5 6.95	113,5 4.47		451 1014	539 1212	44,1 2.69	0,39 0.86	✓
H 300 - 080 - C	H 300 - 080 - D	80 3.15	210 8.27	130 5.12		460 1033	552 1242	53,9 3.29	0,44 0.97	✓
H 300 - 100 - C	H 300 - 100 - D	100 3.94	250 9.84	150 5.91		465 1046	562 1262	65,8 4.02	0,51 1.12	✓
H 300 - 125 - C	H 300 - 125 - D	125 4.92	300 11.81	175 6.89		476 1070	579 1301	78,9 4.81	0,59 1.30	✓

◆ Disposable

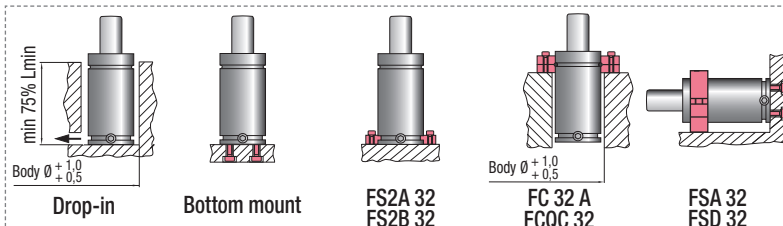

HOW TO ORDER p. 135

INSTALLATION GUIDELINE p. 205



ACTIVE SAFETY



OSAS



USAS



OPAS

OSAS + OSM = OVER STROKE ACTIVE SAFETY + OVER STROKE MARKER

Il nuovo codice sarà fornito solo ad esaurimento del vecchio

The new code will be supplied only when the old will be out of stock

Der neue Kode wird nur angegeben, wenn der alte nicht mehr lieferbar ist

Le nouveau code sera fourni uniquement lorsque le vieux stock sera épuisé

El nuevo código será suministrado sólo cuando se agoten las existencias del antiguo

O novo código irá ser fornecido apenas quando o antigo esgotar stock

easu MANIFOLD p. 247

p. 262

* $F_{1i} =$

Isothermal end force at 100% Cu

p. 16

** $F_{1p} =$

Polytrophic end force at 100% Cu

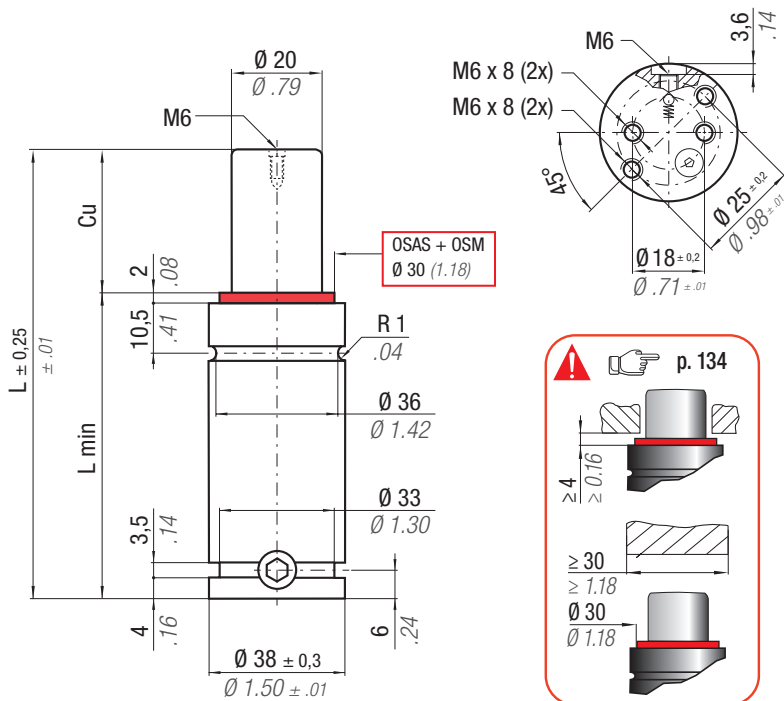

	0 - 80 °C 32 - 176 °F	ΔP ± 0,33 %/°C	P max 150 bar 2175 psi	P min 20 bar 290 psi	S 3,14 cm ² 0.487 in ²	SPM ~ 30 - 100 (at 20°C)	Max Speed 1,8 m/s 70.8 in/s	Maintenance kit 39BMH00500C		
CODE PHASING OUT from 04/2021	NEW	Cu	L	L min	F0	F _{1i} *	F _{1p} **	V0		
H 500 - 010 - C	◆ H 500 - 010 - D	10 0.39	70 2.76	60 2.36	470 1057 ± 5% 150 bar 2175 psi + 20 °C +68 °F	595 1338	673 1512	17,6 1.07	0,32 0.71	✓
H 500 - 013 - C	H 500 - 013 - D	13 0.51	75,7 2.98	62,7 2.47		617 1386	705 1585	20,2 1.23	0,33 0.73	✓
H 500 - 016 - C	H 500 - 016 - D	16 0.63	82 3.23	66 2.60		634 1426	732 1646	22,7 1.39	0,34 0.75	✓
H 500 - 019 - C	H 500 - 019 - D	19 0.75	88 3.46	69 2.72		649 1459	755 1697	25,3 1.54	0,36 0.79	✓
H 500 - 025 - C	H 500 - 025 - D	25 0.98	100 3.94	75 2.95		673 1512	791 1778	30,4 1.86	0,39 0.86	✓
H 500 - 038 - C	H 500 - 038 - D	38 1.50	126 4.96	88 3.46		706 1587	843 1896	41,5 2.53	0,45 0.99	✓
H 500 - 050 - C	H 500 - 050 - D	50 1.97	150 5.91	100 3.94		725 1630	874 1965	51,7 3.15	0,50 1.10	✓
H 500 - 063 - C	H 500 - 063 - D	63 2.48	176,5 6.95	113,5 4.47		737 1658	894 2010	63,1 3.85	0,57 1.26	✓
H 500 - 080 - C	H 500 - 080 - D	80 3.15	210 8.27	130 5.12		753 1692	919 2065	77,2 4.71	0,64 1.41	✓
H 500 - 100 - C	H 500 - 100 - D	100 3.94	250 9.84	150 5.91		763 1716	936 2104	94,3 5.75	0,74 1.63	✓
H 500 - 125 - C	H 500 - 125 - D	125 4.92	300 11.81	175 6.89	772 1737	951 2137	115,5 7.05	0,86 1.90	✓	

◆ Disposable

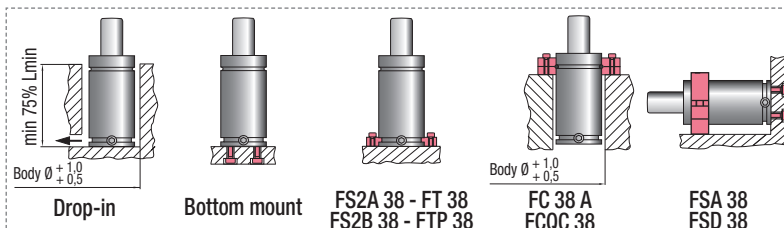

HOW TO ORDER

p. 135

INSTALLATION GUIDELINE

p. 205



OSAS + OSM = OVER STROKE ACTIVE SAFETY + OVER STROKE MARKER

ACTIVE SAFETY



OSAS



USAS



OPAS

Il nuovo codice sarà fornito solo ad esaurimento del vecchio

The new code will be supplied only when the old will be out of stock

Der neue Kode wird nur angegeben, wenn der alte nicht mehr lieferbar ist

Le nouveau code sera fourni uniquement lorsque le vieux stock sera épuisé

El nuevo código será suministrado sólo cuando se agoten las existencias del antiguo

O novo código irá ser fornecido apenas quando o antigo esgotar stock



p. 262

* F_{1i} =

Isothermal end force at 100% Cu



p. 16

** F_{1p} =

Polytrophic end force at 100% Cu

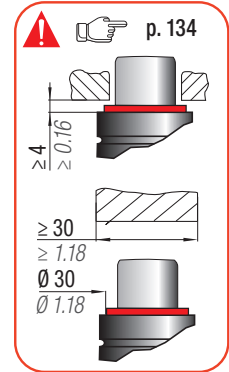
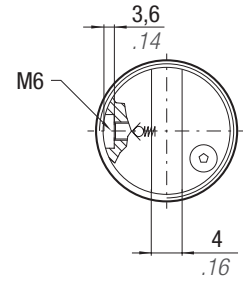
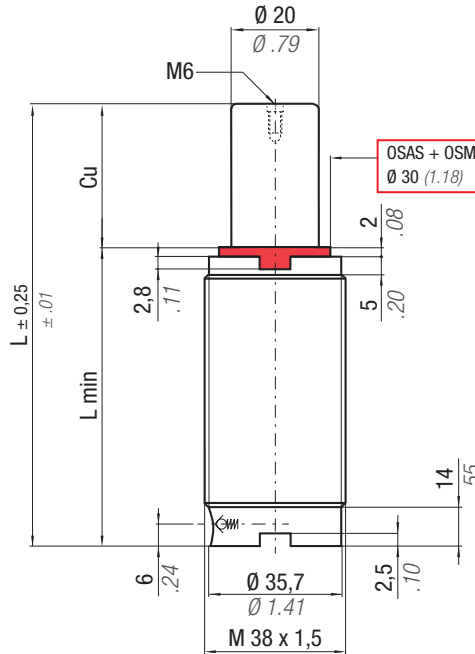

N₂	0 - 80 °C 32 - 176 °F	ΔP ± 0,33 %/°C	P max 150 bar 2175 psi	P min 20 bar 290 psi	S 3,14 cm ² 0,487 in ²	SPM ~ 30 - 100 (at 20°C)	Max Speed 1,8 m/s 70,8 in/s	Maintenance kit 39BMH00500C
----------------------	--------------------------	--------------------------	-------------------------------------	-----------------------------------	-----------------------------------------------------------	---------------------------------------	------------------------------------------	---------------------------------------

CODE PHASING OUT from 04/2021	NEW	Cu		L		L min		F ₀		F _{1i} *		F _{1p} **		V ₀		~Kg	~lb	PED 2014/68/EU								
		mm	inch	mm	inch	mm	inch	daN	lb	daN	lb	daN	lb	cm ³	in ³											
HF 500 - 010 - C	♦ HF 500 - 010 - D	10	0.39	70	2.76	60	2.36	470 ± 5% 1057 150 bar 2175 psi + 20 °C +68 °F	595	1338	673	1512	17,6	1,07	0,31	0,68	✓									
HF 500 - 013 - C	HF 500 - 013 - D	13	0.51	75,7	2.98	62,7	2.47											617	1386	705	1585	20,2	1.23	0,32	0,71	✓
HF 500 - 016 - C	HF 500 - 016 - D	16	0.63	82	3.23	66	2.60											634	1426	732	1646	22,7	1.39	0,34	0,75	✓
HF 500 - 019 - C	HF 500 - 019 - D	19	0.75	88	3.46	69	2.72											649	1459	755	1697	25,3	1.54	0,35	0,77	✓
HF 500 - 025 - C	HF 500 - 025 - D	25	0.98	100	3.94	75	2.95											673	1512	791	1778	30,4	1.86	0,38	0,84	✓
HF 500 - 038 - C	HF 500 - 038 - D	38	1.50	126	4.96	88	3.46											706	1587	843	1896	41,5	2.53	0,44	0,97	✓
HF 500 - 050 - C	HF 500 - 050 - D	50	1.97	150	5.91	100	3.94											725	1630	874	1965	51,7	3.15	0,50	1.10	✓
HF 500 - 063 - C	HF 500 - 063 - D	63	2.48	176,5	6.95	113,5	4.47											737	1658	894	2010	63,1	3.85	0,56	1.23	✓
HF 500 - 080 - C	HF 500 - 080 - D	80	3.15	210	8.27	130	5.12											753	1692	919	2065	77,2	4.71	0,64	1.41	✓
HF 500 - 100 - C	HF 500 - 100 - D	100	3.94	250	9.84	150	5.91											763	1716	936	2104	94,3	5.75	0,73	1.61	✓
HF 500 - 125 - C	HF 500 - 125 - D	125	4.92	300	11.81	175	6.89											772	1737	951	2137	115,5	7.05	0,85	1.87	✓

♦ Disposable

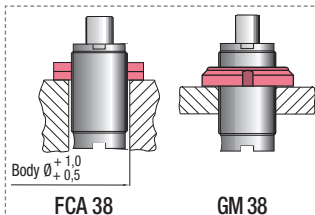
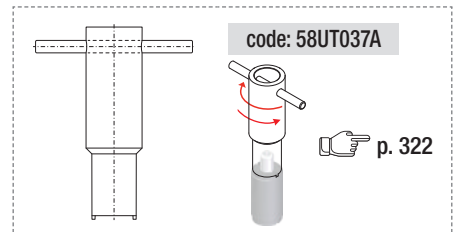

HOW TO ORDER
Hand icon p. 135

INSTALLATION GUIDELINE
Hand icon p. 205

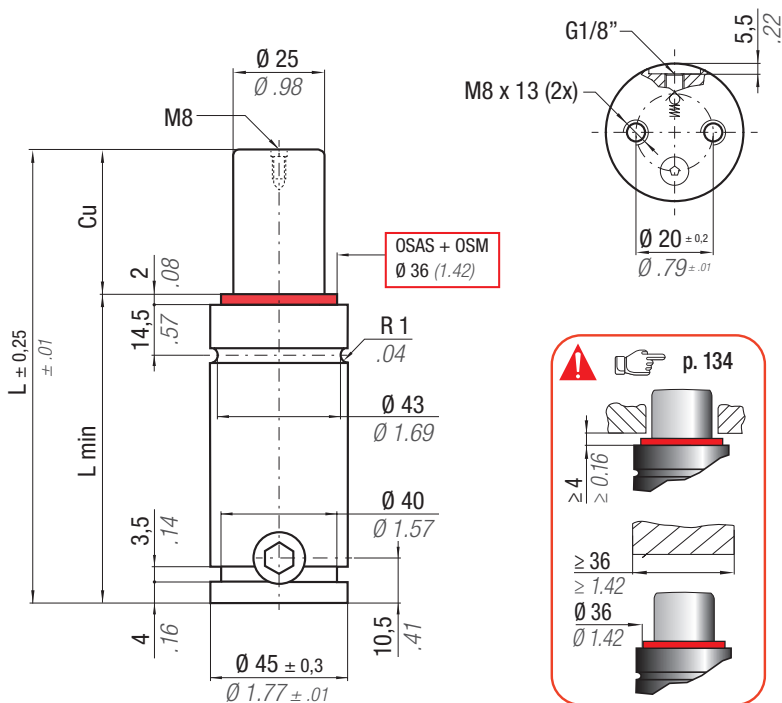

OSAS + OSM = OVER STROKE ACTIVE SAFETY + OVER STROKE MARKER



Il nuovo codice sarà fornito solo ad esaurimento del vecchio
The new code will be supplied only when the old will be out of stock

ACTIVE SAFETY

Der neue Kode wird nur angegeben, wenn der alte nicht mehr lieferbar ist



Le nouveau code sera fourni uniquement lorsque le vieux stock sera écoulé



El nuevo código será suministrado sólo cuando se agoten las existencias del antiguo

O novo código irá ser fornecido apenas quando o antigo esgotar stock

easu MANIFOLD p. 247

p. 262



* $F_{1i} =$

Isothermal end force at 100% Cu

p. 16

** $F_{1p} =$

Polytrophic end force at 100% Cu

	0 - 80 °C 32 - 176 °F	ΔP ± 0,33 %/°C	P max 150 bar 2175 psi	P min 20 bar 290 psi	S 4,91 cm ² 0.761 in ²	SPM ~ 20 - 100 (at 20°C)	Max Speed 1,8 m/s 70.8 in/s	Maintenance kit 39BMH00700D
--	--------------------------	---------------------------	-------------------------------------	-----------------------------------	-----------------------------------------------------------	---------------------------------------	------------------------------------------	---------------------------------------

CODE PHASING OUT from 04/2021	NEW	Cu		L		L min		F0 Initial force		F _{1i} * End force *		F _{1p} ** End force **		V0		PED 2014/68/EU	
		mm	inch	mm	inch	mm	inch	daN	lb	daN	lb	daN	lb	cm ³	in ³	~Kg	~lb
H 700 - 010 - D	◆ H 700 - 010 - E	10	0.39	105	4.13	95	3.74	740 1664 ± 5% 150 bar 2175 psi + 20 °C +68 °F	967	2173	1106	2487	24,0	1.46	0,90	1.98	✓
H 700 - 013 - D	H 700 - 013 - E	13	0.50	110,7	4.35	97,7	3.85		1010	2271	1173	2636	27,4	1.67	0,91	2.01	✓
H 700 - 025 - D	H 700 - 025 - E	25	0.98	135	5.31	110	4.33		1108	2490	1325	2980	42,2	2.58	1,00	2.20	✓
H 700 - 038 - D	H 700 - 038 - E	38	1.50	161	6.34	123	4.84		1168	2625	1422	3196	58,1	3.55	1,09	2.40	✓
H 700 - 050 - D	H 700 - 050 - E	50	1.97	185	7.28	135	5.31		1202	2703	1478	3323	72,7	4.44	1,17	2.58	✓
H 700 - 063 - D	H 700 - 063 - E	63	2.48	211,5	8.33	148,5	5.85		1224	2752	1514	3403	89,0	5.43	1,26	2.78	✓
-	■ H 700 - 075 - E	75	2.95	235	9.25	160	6.30		1246	2801	1549	3482	103,2	6.30	1,34	2.95	✓
H 700 - 080 - D	H 700 - 080 - E	80	3.15	245	9.65	165	6.50		1252	2814	1559	3505	109,2	6.66	1,37	3.02	✓
H 700 - 100 - D	H 700 - 100 - E	100	3.94	285	11.22	185	7.28		1271	2856	1590	3575	133,5	8.15	1,51	3.33	✓
H 700 - 125 - D	H 700 - 125 - E	125	4.92	335	13.19	210	8.27		1287	2892	1617	3635	163,9	10.00	1,67	3.68	✓
-	■ H 700 - 150 - E	150	5.91	385	15.16	235	9.25	1298	2918	1636	3678	194,3	11.85	1,86	4.10	✓	
H 700 - 160 - D	H 700 - 160 - E	160	6.30	405	15.94	245	9.65	1301	2926	1642	3691	206,5	12.60	1,91	4.21	✓	
-	■ H 700 - 175 - E	175	6.89	435	17.13	260	10.24	1306	2936	1650	3709	224,7	13.71	2,03	4.48	✓	
■ H 700 - 200 - D	H 700 - 200 - E	200	7.87	485	19.09	285	11.22	1313	2951	1660	3733	255,2	15.57	2,20	4.85	✓	

◆ Disposable

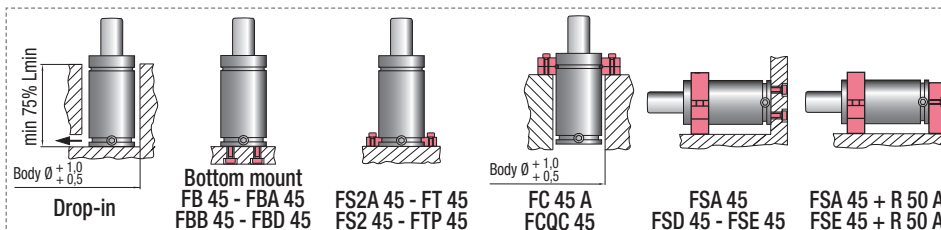

HOW TO ORDER

p. 135

INSTALLATION GUIDELINE

p. 205



OSAS + OSM = OVER STROKE ACTIVE SAFETY + OVER STROKE MARKER

ACTIVE SAFETY



OSAS



USAS



OPAS

Il nuovo codice sarà fornito solo ad esaurimento del vecchio
The new code will be supplied only when the old will be out of stock
Der neue Kode wird nur angegeben, wenn der alte nicht mehr lieferbar ist
Le nouveau code sera fourni uniquement lorsque le vieux stock sera écoulé
El nuevo código será suministrado sólo cuando se agoten las existencias del antiguo
O novo código irá ser fornecido apenas quando o antigo esgotar stock

easU MANIFOLD p. 247

p. 262

* F_{1i} =

Isothermal end force at 100% Cu p. 16

** F_{1p} =

Polytropic end force at 100% Cu p. 16

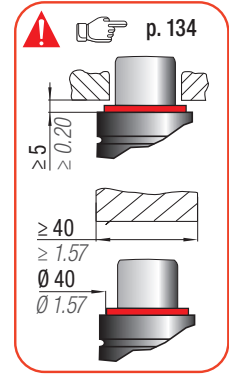
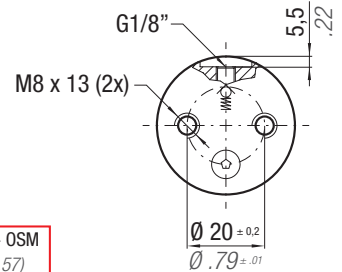
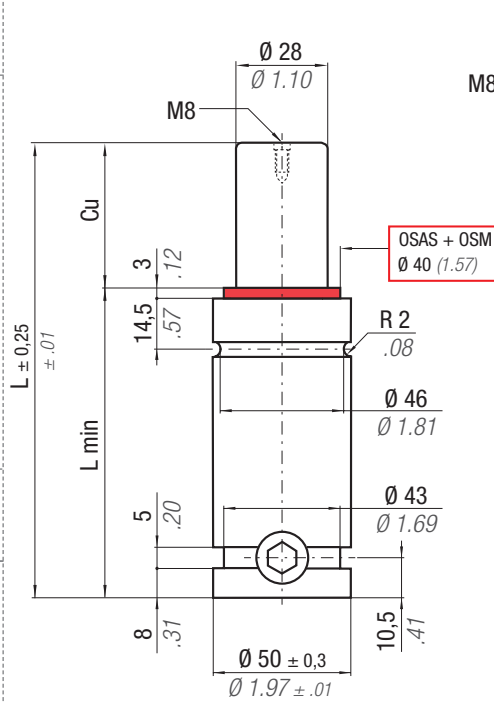

	0 - 80 °C 32 - 176 °F	ΔP ± 0,33 %/°C	P max 150 bar 2175 psi	P min 20 bar 290 psi	S 6,15 cm ² 0,953 in ²	SPM ~ 15 - 100 (at 20°C)	Max Speed 1,8 m/s 70,8 in/s	Maintenance kit 39BMH01000D
--	--------------------------	---------------------------	-------------------------------------	-----------------------------------	-----------------------------------------------------------	---------------------------------------	------------------------------------------	---------------------------------------

CODE PHASING OUT from 04/2021	NEW	Cu		L		L min		F ₀		F _{1i} *		F _{1p} **		V ₀		PED 2014/68/EU		
		mm	inch	mm	inch	mm	inch	daN	lb	daN	lb	daN	lb	cm ³	in ³		~Kg	~lb
H 1000 - 013 - D	◆ H 1000 - 013 - E	13	0.50	120,7	4.74	107,7	4.24	920 2068 ± 5% 150 bar 2175 psi + 20 °C +68 °F		1201	2701	1371	3082	40	2.47	1,21	2.67	✓
-	■ H 1000 - 016 - E	16	0.63	127	5.00	111	4.37			1237	2781	1425	3204	45,3	2.76	1,25	2.76	✓
H 1000 - 025 - D	H 1000 - 025 - E	25	0.98	145	5.71	120	4.72			1324	2976	1559	3505	59	3.60	1,32	2.91	✓
H 1000 - 038 - D	H 1000 - 038 - E	38	1.50	171	6.73	133	5.24			1405	3159	1687	3793	79	4.81	1,43	3.15	✓
H 1000 - 050 - D	H 1000 - 050 - E	50	1.97	195	7.68	145	5.71			1455	3271	1767	3973	97	5.92	1,53	3.37	✓
H 1000 - 063 - D	H 1000 - 063 - E	63	2.48	221	8.74	158	6.22			1493	3357	1830	4113	117	7.13	1,64	3.62	✓
H 1000 - 075 - D	H 1000 - 075 - E	75	2.95	245	9.65	170	6.69			1520	3417	1873	4210	135	8.24	1,74	3.84	✓
H 1000 - 080 - D	H 1000 - 080 - E	80	3.15	255	10.04	175	6.89			1529	3438	1888	4244	143	8.70	1,78	3.92	✓
H 1000 - 100 - D	H 1000 - 100 - E	100	3.94	295	11.61	195	7.68			1559	3504	1937	4354	173	10.56	1,96	4.32	✓
H 1000 - 125 - D	H 1000 - 125 - E	125	4.92	345	13.58	220	8.66			1585	3562	1979	4450	211	12.88	2,17	4.78	✓
H 1000 - 150 - D	H 1000 - 150 - E	150	5.91	395	15.55	245	9.65			1603	3604	2010	4519	249	15.20	2,38	5.25	✓
H 1000 - 160 - D	H 1000 - 160 - E	160	6.30	415	16.34	255	10.04			1609	3617	2020	4541	264	16.13	2,46	5.42	✓
H 1000 - 175 - D	H 1000 - 175 - E	175	6.89	445	17.52	270	10.63			1617	3635	2033	4570	287	17.52	2,59	5.71	✓
H 1000 - 200 - D	H 1000 - 200 - E	200	7.87	495	19.49	295	11.61			1627	3659	2051	4610	325	19.84	2,79	6.15	✓
H 1000 - 250 - D	H 1000 - 250 - E	250	9.84	595	23.43	345	13.58			1643	3694	2077	4669	401	24.48	3,21	7.08	✓
H 1000 - 300 - D	H 1000 - 300 - E	300	11.81	695	27.36	395	15.55			1654	3718	2095	4710	477	29.13	3,63	8.00	✓

◆ Disposable

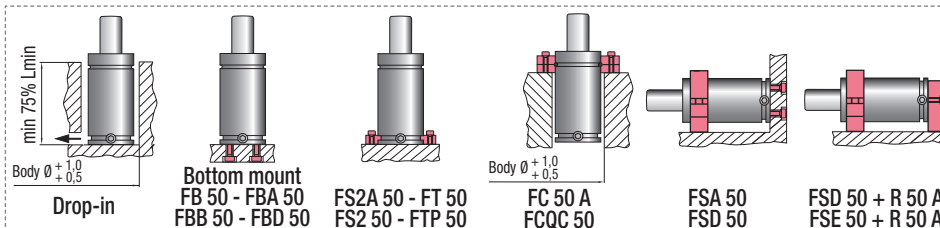

HOW TO ORDER

p. 135

INSTALLATION GUIDELINE

p. 205



ACTIVE SAFETY



OSAS



USAS



OPAS

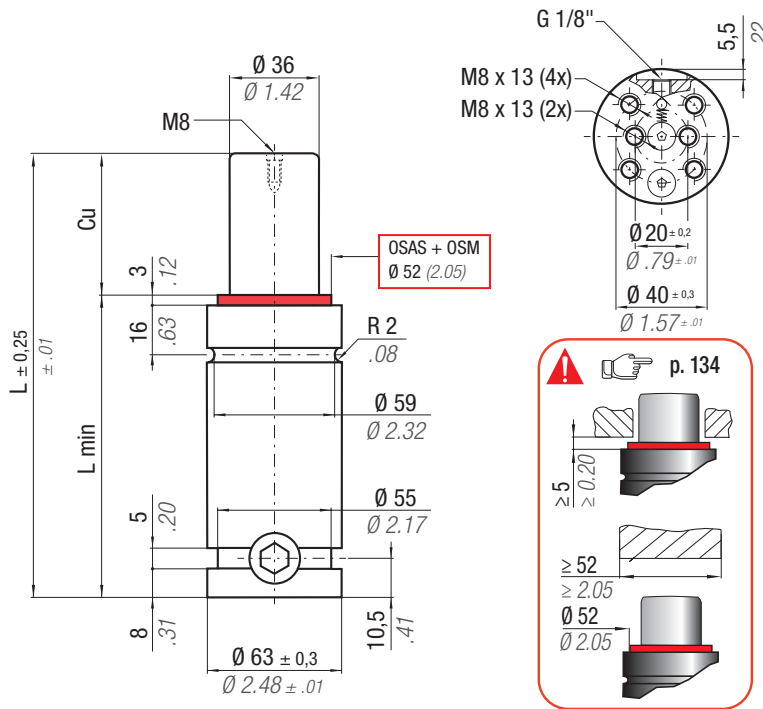

OSAS + OSM = OVER STROKE ACTIVE SAFETY + OVER STROKE SAFETY MARKER

Il nuovo codice sarà fornito solo ad esaurimento del vecchio

The new code will be supplied only when the old will be out of stock

Der neue Kode wird nur angegeben, wenn der alte nicht mehr lieferbar ist

Le nouveau code sera fourni uniquement lorsque le vieux stock sera écoulé

El nuevo código será suministrado sólo cuando se agoten las existencias del antiguo

O novo código irá ser fornecido apenas quando o antigo esgotar stock

easu MANIFOLD p. 247

p. 262

* $F_{1i} =$

Isothermal end force at 100% Cu

p. 16

** $F_{1p} =$

Polytrophic end force at 100% Cu

N ₂		0 - 80 °C 32 - 176 °F	ΔP ± 0,33 %/°C	P max 150 bar 2175 psi	P min 20 bar 290 psi	S 10,17 cm ² 1.576 in ²	SPM ~ 15 - 100 (at 20°C)	Max Speed 1,8 m/s 70.8 in/s	Maintenance kit 39BMH01500CH
CODE	NEW	Cu	L	L min	F ₀	F _{1i} *	F _{1p} **	V ₀	PED
PHASING OUT from 04/2021		mm inch	mm inch	mm inch	Initial force daN lb	End force * daN lb	End force ** daN lb	cm ³ in ³	~Kg ~lb
H 1500 - 013 - C	◆ H 1500 - 013 - D	13 0,51	120,7 4,75	107,7 4,24	1530 3440 ± 5% 150 bar 2175 psi + 20 °C +68 °F	1982 4456	2260 5081	67 4.10	1,98 4.37
H 1500 - 025 - C	H 1500 - 025 - D	25 0,98	145 5,71	120 4,72		2177 4895	2560 5755	99 6.02	2,13 4.70
H 1500 - 038 - C	H 1500 - 038 - D	38 1,50	171 6,73	133 5,24		2306 5183	2762 6210	132 8.06	2,29 5.05
H 1500 - 050 - C	H 1500 - 050 - D	50 1,97	195 7,68	145 5,71		2383 5358	2887 6490	163 9.95	2,44 5.38
H 1500 - 063 - C	H 1500 - 063 - D	63 2,48	221 8,70	158 6,22		2443 5493	2983 6707	197 11.99	2,60 5.73
H 1500 - 075 - C	H 1500 - 075 - D	75 2,95	245 9,65	170 6,69		2484 5585	3050 6857	227 13.88	2,75 6.06
H 1500 - 080 - C	H 1500 - 080 - D	80 3,15	255 10,04	175 6,89		2499 5617	3074 6910	240 14.66	2,81 6.19
H 1500 - 100 - C	H 1500 - 100 - D	100 3,94	295 11,61	195 7,68		2544 5720	3148 7078	292 17.80	3,03 6.68
H 1500 - 125 - C	H 1500 - 125 - D	125 4,92	345 13,58	220 8,66		2584 5809	3214 7224	356 21.73	3,34 7.36
H 1500 - 150 - C	H 1500 - 150 - D	150 5,91	395 15,55	245 9,65		2612 5873	3260 7329	420 25.65	3,64 8.02
H 1500 - 160 - C	H 1500 - 160 - D	160 6,30	415 16,34	255 10,04		2621 5893	3275 7363	446 27.22	3,77 8.31
H 1500 - 175 - C	H 1500 - 175 - D	175 6,89	445 17,52	270 10,63		2633 5920	3295 7408	485 29.58	3,95 8.71
H 1500 - 200 - C	H 1500 - 200 - D	200 7,87	495 19,49	295 11,61		2650 5957	3322 7469	549 33.51	4,26 9.39
H 1500 - 250 - C	H 1500 - 250 - D	250 9,84	595 23,43	345 13,58		2722 6119	3443 7740	661 40.36	4,99 11.00
H 1500 - 300 - C	H 1500 - 300 - D	300 11,81	695 27,36	395 15,55		2804 6303	3582 8052	764 46.59	5,81 12.81

◆ Disposable

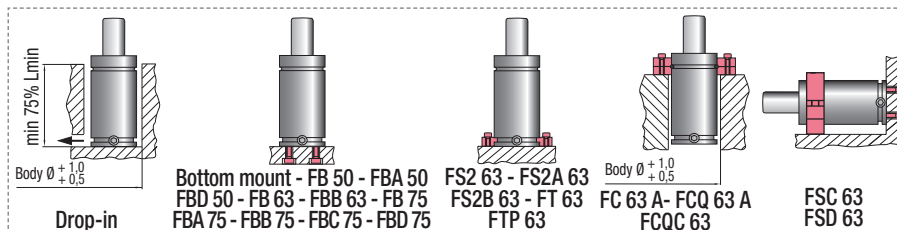

HOW TO ORDER

p. 135

INSTALLATION GUIDELINE

p. 205

ISO 11901 - 4 39D 838 (VW)	VDI 3003 Blatt 4	B2 4008 (BMW)	075.90.65 (FCA)
-------------------------------	------------------	---------------	-----------------



OSAS + OSM = OVER STROKE ACTIVE SAFETY + OVER STROKE MARKER

ACTIVE SAFETY



OSAS



USAS



OPAS

Il nuovo codice sarà fornito solo ad esaurimento del vecchio
The new code will be supplied only when the old will be out of stock
Der neue Kode wird nur angegeben, wenn der alte nicht mehr lieferbar ist
Le nouveau code sera fourni uniquement lorsque le vieux stock sera écoulé
El nuevo código será suministrado sólo cuando se agoten las existencias del antiguo
O novo código irá ser fornecido apenas quando o antigo esgotar stock

easu MANIFOLD p. 247 p. 262

* F_{1i} = Isothermal end force at 100% Cu p. 16
** F_{1p} = Polytrophic end force at 100% Cu

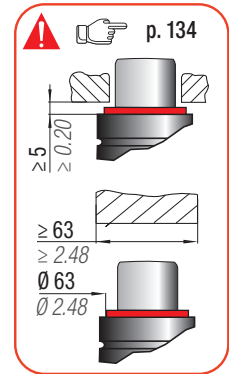
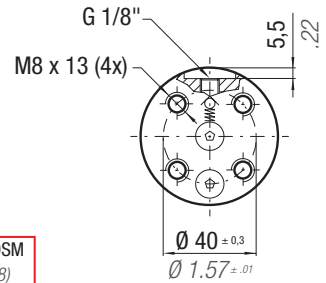
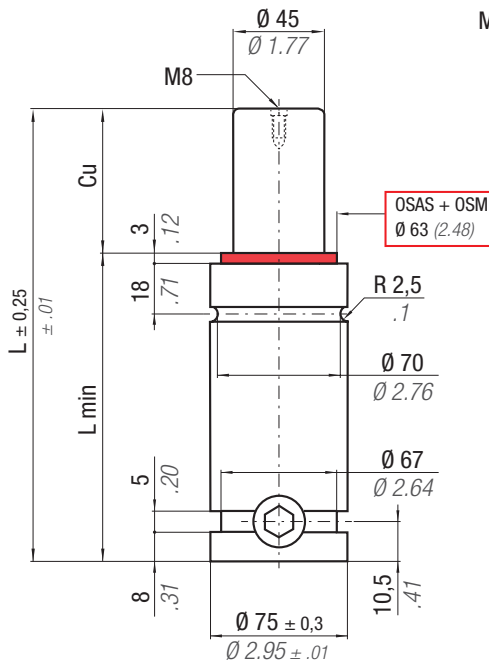

N ₂	0 - 80 °C 32 - 176 °F	ΔP ± 0,33 %/°C	P max 150 bar 2175 psi	P min 20 bar 290 psi	S 15,90 cm ² 2.465 in ²	SPM ~ 15 - 100 (at 20°C)	Max Speed 1,8 m/s 70.8 in/s	Maintenance kit 39BMH02400DH
----------------	--------------------------	---------------------------	------------------------------	----------------------------	-----------------------------------------------------	--------------------------------	-----------------------------------	---------------------------------

CODE PHASING OUT from 04/2021	NEW	Cu		L		L min		F ₀		F _{1i} *		F _{1p} **		V ₀		~Kg	~lb	PED 2014/68/EU	
		mm	inch	mm	inch	mm	inch	daN	lb	daN	lb	daN	lb	cm ³	in ³				
H 2400 - 025 - D	H 2400 - 025 - E	25	0.98	160	6.30	135	5.31	2385	5362	± 5%	3282	7378	3814	8574	169	10.32	3,34	7.36	✓
H 2400 - 038 - D	H 2400 - 038 - E	38	1.50	186	7.32	148	5.83				3495	7857	4146	9321	220	13.44	3,55	7.83	✓
H 2400 - 050 - D	H 2400 - 050 - E	50	1.97	210	8.27	160	6.30				3632	8165	4363	9807	267	16.31	3,75	8.27	✓
H 2400 - 063 - D	H 2400 - 063 - E	63	2.48	236	9.31	173	6.81				3741	8410	4537	10200	318	19.42	3,96	8.73	✓
H 2400 - 075 - D	H 2400 - 075 - E	75	2.95	260	10.24	185	7.28				3818	8583	4662	10480	366	22.30	4,15	9.15	✓
H 2400 - 080 - D	H 2400 - 080 - E	80	3.15	270	10.63	190	7.48				3845	8644	4706	10579	385	23.50	4,23	9.33	✓
H 2400 - 100 - D	H 2400 - 100 - E	100	3.94	310	12.20	210	8.27				3933	8842	4850	10902	464	28.29	4,51	9.94	✓
H 2400 - 125 - D	H 2400 - 125 - E	125	4.92	360	14.17	235	9.25				4012	9019	4979	11192	562	34.28	4,91	10.82	✓
H 2400 - 150 - D	H 2400 - 150 - E	150	5.91	410	16.14	260	10.24				4068	9146	5072	11402	660	40.28	5,32	11.73	✓
H 2400 - 160 - D	H 2400 - 160 - E	160	6.30	430	16.93	270	10.63				4087	9187	5103	11471	699	42.68	5,49	12.10	✓
H 2400 - 175 - D	H 2400 - 175 - E	175	6.89	460	18.11	285	11.22	4111	9243	5144	11563	758	46.27	5,73	12.63	✓			
H 2400 - 200 - D	H 2400 - 200 - E	200	7.87	510	20.08	310	12.20	4145	9319	5200	11690	856	52.26	6,14	13.54	✓			
H 2400 - 250 - D	H 2400 - 250 - E	250	9.84	610	24.02	360	14.17	4195	9431	5283	11876	1053	64.25	6,95	15.32	✓			
H 2400 - 275 - D	H 2400 - 275 - E	275	10.83	660	25.98	385	15.16	4214	9473	5314	11947	1151	70.24	7,36	16.23	✓			
H 2400 - 300 - D	H 2400 - 300 - E	300	11.81	710	27.95	410	16.14	4230	9509	5341	12007	1249	76.22	7,77	17.13	✓			

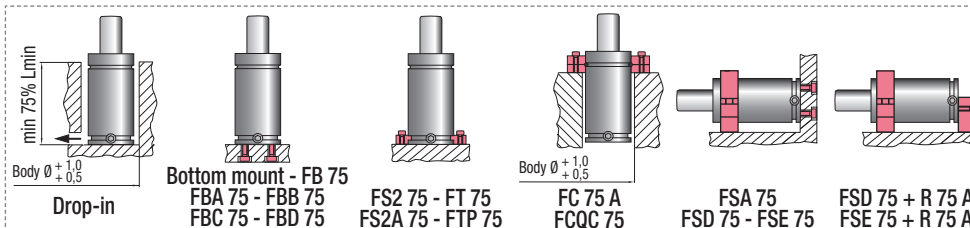

HOW TO ORDER
 p. 135
INSTALLATION GUIDELINE
 p. 205

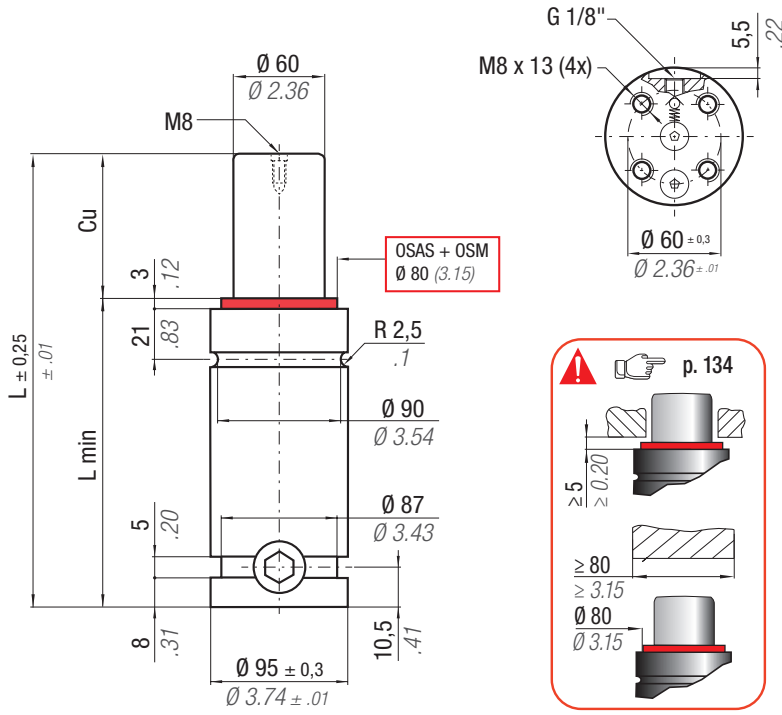

OSAS + OSM = OVER STROKE ACTIVE SAFETY + OVER STROKE MARKER



Il nuovo codice sarà fornito solo ad esaurimento del vecchio
 The new code will be supplied only when the old will be out of stock
 Der neue Kode wird nur angegeben, wenn der alte nicht mehr lieferbar ist
 Le nouveau code sera fourni uniquement lorsque le vieux stock sera écoulé
 El nuevo código será suministrado sólo cuando se agoten las existencias del antiguo
 O novo código irá ser fornecido apenas quando o antigo esgotar stock

ACTIVE SAFETY



OSAS



USAS



OPAS

easu MANIFOLD p. 247

p. 262

* F_{1i} = Isothermal end force at 100% Cu

p. 16

** F_{1p} = Polytrophic end force at 100% Cu

p. 16

N ₂	0 - 80 °C 32 - 176 °F	ΔP ± 0,33 %/°C	P max 150 bar 2175 psi	P min 20 bar 290 psi	S 28,27 cm ² 4.382 in ²	SPM ~ 15 - 100 (at 20°C)	Max Speed 1,8 m/s 70.8 in/s	Maintenance kit 39BMH04200DH
----------------	--------------------------	---------------------------	-------------------------------------	-----------------------------------	------------------------------------------------------------	---------------------------------------	------------------------------------------	----------------------------------------

CODE PHASING OUT from 04/2021	NEW	Cu		L		L min		F ₀ Initial force		F _{1i} * End force *		F _{1p} ** End force **		V ₀		PED 2014/68/EU		
		mm	inch	mm	inch	mm	inch	daN	lb	daN	lb	daN	lb	cm ³	in ³	~Kg	~lb	✓
H 4200 - 025 - D	H 4200 - 025 - E	25	0.98	170	6.69	145	5.71	4240 9532 ± 5%	150 bar 2175 psi	5877	13212	6846	15389	295	17.99	5,76	12.70	✓
H 4200 - 038 - D	H 4200 - 038 - E	38	1.50	196	7.72	158	6.22			6312	14190	7526	16919	378	23.09	6,12	13.49	✓
H 4200 - 050 - D	H 4200 - 050 - E	50	1.97	220	8.66	170	6.69			6601	14840	7987	17955	455	27.79	6,45	14.22	✓
H 4200 - 063 - D	H 4200 - 063 - E	63	2.48	246	9.70	183	7.20			6838	15371	8369	18815	539	32.88	6,80	14.99	✓
H 4200 - 075 - D	H 4200 - 075 - E	75	2.95	270	10.63	195	7.68			7008	15755	8648	19441	616	37.58	7,13	15.72	✓
H 4200 - 080 - D	H 4200 - 080 - E	80	3.15	280	11.02	200	7.87			7069	15892	8748	19666	648	39.54	7,27	16.03	✓
H 4200 - 100 - D	H 4200 - 100 - E	100	3.94	320	12.60	220	8.66			7269	16342	9078	20408	777	47.38	7,76	17.11	✓
H 4200 - 125 - D	H 4200 - 125 - E	125	4.92	370	14.57	245	9.65			7447	16742	9374	21074	938	57.22	8,45	18.63	✓
H 4200 - 150 - D	H 4200 - 150 - E	150	5.91	420	16.54	270	10.63			7581	17043	9599	21578	1098	67.02	9,13	20.13	✓
H 4200 - 160 - D	H 4200 - 160 - E	160	6.30	440	17.32	280	11.02			7656	17211	9724	21861	1156	70.56	9,40	20.72	✓
H 4200 - 175 - D	H 4200 - 175 - E	175	6.89	470	18.50	295	11.61	7712	17338	9820	22077	1253	76.44	9,82	21.65	✓		
H 4200 - 200 - D	H 4200 - 200 - E	200	7.87	520	20.47	320	12.60	7791	17515	9953	22376	1413	86.24	10,50	23.15	✓		
H 4200 - 250 - D	H 4200 - 250 - E	250	9.84	620	24.41	370	14.57	7908	17777	10151	22821	1734	105.83	11,87	26.17	✓		
H 4200 - 300 - D	H 4200 - 300 - E	300	11.81	720	28.35	420	16.54	8123	18260	10519	23648	2016	123.02	13,24	29.19	✓		

H HF

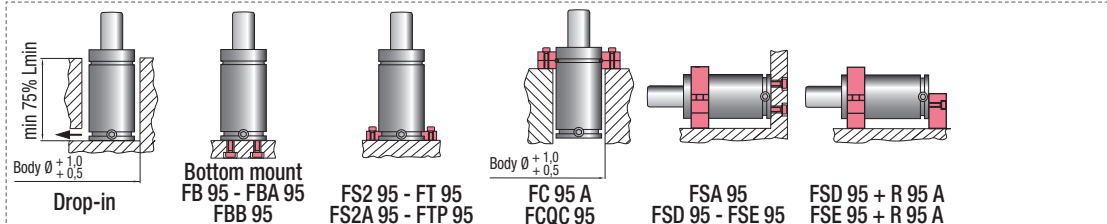

HOW TO ORDER
 p. 135
INSTALLATION GUIDELINE
 p. 205

ISO 11901 - 4 39D 838 (VW)	VDI 3003 Blatt 4	B2 4008 (BMW)	075.90.65 (FCA)
-------------------------------	------------------	---------------	-----------------



OSAS + OSM = OVER STROKE ACTIVE SAFETY + OVER STROKE MARKER

ACTIVE SAFETY



OSAS



USAS



OPAS

Il nuovo codice sarà fornito solo ad esaurimento del vecchio
 The new code will be supplied only when the old will be out of stock
 Der neue Kode wird nur angegeben, wenn der alte nicht mehr lieferbar ist
 Le nouveau code sera fourni uniquement lorsque le vieux stock sera écoulé
 El nuevo código será suministrado sólo cuando se agoten las existencias del antiguo
 O novo código irá ser fornecido apenas quando o antigo esgotar stock

easU MANIFOLD p. 247

p. 262

* F_{1i} = Isothermal end force at 100% Cu p. 16

** F_{1p} = Polytrophic end force at 100% Cu

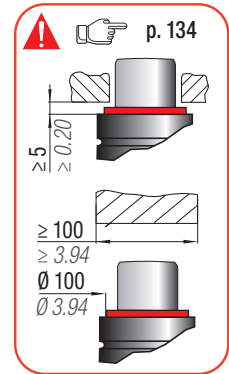
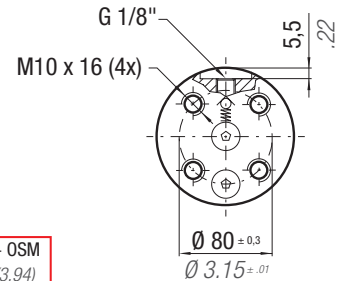
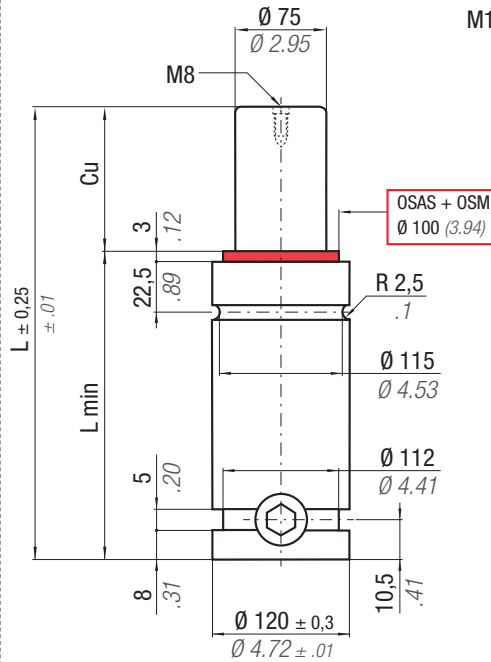

N₂	0 - 80 °C 32 - 176 °F	ΔP ± 0,33 %/°C	P max 150 bar 2175 psi	P min 20 bar 290 psi	S 44,18 cm ² 6.848 in ²	SPM ~ 15 - 100 (at 20°C)	Max Speed 1,8 m/s 70.8 in/s	Maintenance kit 39BMH06600DH
----------------------	--------------------------	---------------------------	-------------------------------------	-----------------------------------	------------------------------------------------------------	---------------------------------------	------------------------------------------	----------------------------------------

CODE PHASING OUT from 04/2021	NEW	Cu		L		L min		F ₀		F _{1i} *		F _{1p} **		V ₀		~Kg	~lb	PED 2014/68/EU
		mm	inch	mm	inch	mm	inch	daN	lb	daN	lb	daN	lb	cm ³	in ³			
H 6600 - 025 - D	H 6600 - 025 - E	25	0.98	190	7.48	165	6.50	6630 ± 5%	14904	8646	19437	9874	22198	551	33.65	10,35	22.82	✓
H 6600 - 038 - D	H 6600 - 038 - E	38	1.50	216	8.50	178	7.01			9243	20779	10789	24255	688	42.00	10,89	24.01	✓
H 6600 - 050 - D	H 6600 - 050 - E	50	1.97	240	9.45	190	7.48			9656	21708	11434	25704	815	49.70	11,37	25.07	✓
H 6600 - 063 - D	H 6600 - 063 - E	63	2.48	266	10.47	203	7.99			10004	22490	11984	26941	951	58.05	11,93	26.30	✓
H 6600 - 075 - D	H 6600 - 075 - E	75	2.95	290	11.42	215	8.46			10261	23067	12394	27863	1078	65.76	12,39	27.32	✓
H 6600 - 080 - D	H 6600 - 080 - E	80	3.15	300	11.81	220	8.66			10354	23276	12543	28199	1130	68.98	12,60	27.78	✓
H 6600 - 100 - D	H 6600 - 100 - E	100	3.94	340	13.39	240	9.45			10663	23972	13044	29324	1341	81.82	13,30	29.32	✓
H 6600 - 125 - D	H 6600 - 125 - E	125	4.92	390	15.35	265	10.43			10950	24617	13512	30377	1604	97.88	14,33	31.59	✓
H 6600 - 150 - D	H 6600 - 150 - E	150	5.91	440	17.32	290	11.42			11166	25101	13866	31171	1867	113.93	15,35	33.84	✓
H 6600 - 160 - D	H 6600 - 160 - E	160	6.30	460	18.11	300	11.81			11237	25262	13984	31437	1972	120.36	15,75	34.72	✓
H 6600 - 175 - D	H 6600 - 175 - E	175	6.89	490	19.29	315	12.40			11333	25477	14142	31793	2130	129.99	16,36	36.07	✓
H 6600 - 200 - D	H 6600 - 200 - E	200	7.87	540	21.26	340	13.39			11466	25777	14364	32291	2393	146.05	17,38	38.32	✓
H 6600 - 250 - D	H 6600 - 250 - E	250	9.84	640	25.20	390	15.35			11667	26228	14698	33042	2920	178.16	19,42	42.81	✓
H 6600 - 300 - D	H 6600 - 300 - E	300	11.81	740	29.13	440	17.32			11846	26630	14998	33718	3432	209.42	21,57	47.55	✓

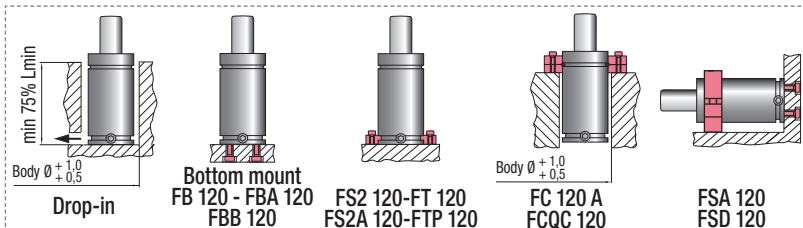

HOW TO ORDER

p. 135

INSTALLATION GUIDELINE

p. 205

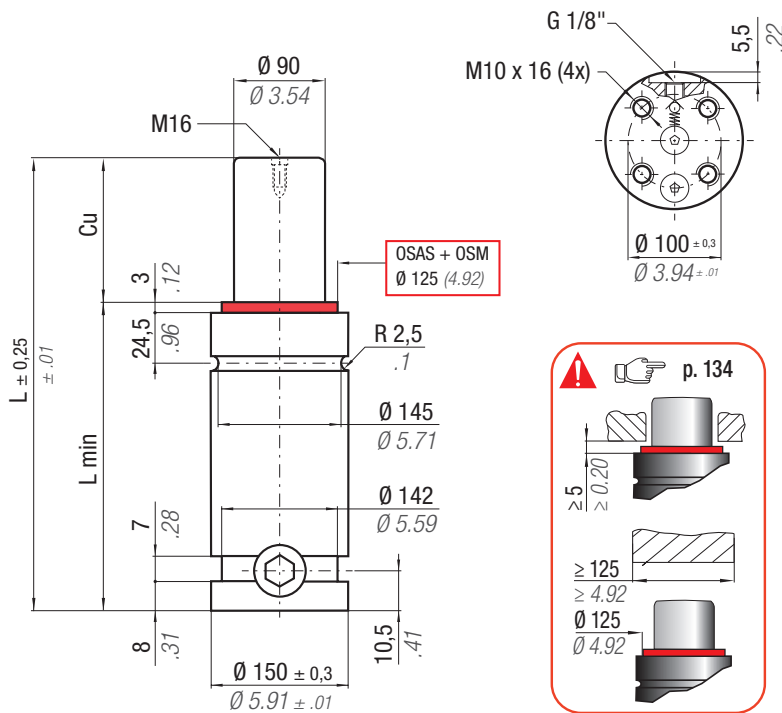

OSAS + OSM = OVER STROKE ACTIVE SAFETY + OVER STROKE MARKER



Il nuovo codice sarà fornito solo ad esaurimento del vecchio

The new code will be supplied only when the old will be out of stock

Der neue Kode wird nur angegeben, wenn der alte nicht mehr lieferbar ist

Le nouveau code sera fourni uniquement lorsque le vieux stock sera épuisé

El nuevo código será suministrado sólo cuando se agoten las existencias del antiguo

O novo código irá ser fornecido apenas quando o antigo esgotar stock

ACTIVE SAFETY



OSAS



USAS



OPAS

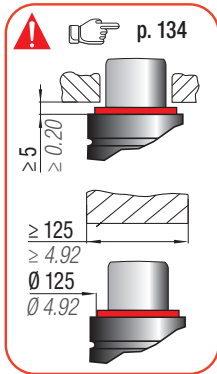

easu MANIFOLD p. 247

p. 262

* F_{1i} =

Isothermal end force at 100% Cu

p. 16

** F_{1p} =

Polytrophic end force at 100% Cu

p. 16

N ₂	0 - 80 °C 32 - 176 °F	ΔP ± 0,33 %/°C	P max 150 bar 2175 psi	P min 20 bar 290 psi	S 63,62 cm ² 9.861 in ²	SPM ~ 15 - 80 (at 20°C)	Max Speed 1,8 m/s 70.8 in/s	Maintenance kit 39BMH09500C
----------------	--------------------------	-------------------	------------------------------	----------------------------	-----------------------------------------------------	-------------------------------	-----------------------------------	--------------------------------

CODE PHASING OUT from 04/2021	NEW	Cu		L		L min		F ₀ Initial force		F _{1i} * End force *		F _{1p} ** End force **		V ₀		PED 2014/68/EU		
		mm	inch	mm	inch	mm	inch	daN	lb	daN	lb	daN	lb	cm ³	in ³	-Kg	-lb	✓
H 9500 - 025 - C	H 9500 - 025 - D	25	0.98	205	8.07	180	7.09	9540 ± 5%	21446	12146	27306	13759	30931	867	52.89	18,00	39.68	✓
H 9500 - 038 - C	H 9500 - 038 - D	38	1.50	231	9.09	193	7.60			12927	29061	14945	33598	1074	65.53	18,82	41.49	✓
H 9500 - 050 - C	H 9500 - 050 - D	50	1.97	255	10.04	205	8.07			13470	30282	15785	35485	1265	77.18	19,58	43.17	✓
H 9500 - 063 - C	H 9500 - 063 - D	63	2.48	281	11.06	218	8.58			13930	31315	16504	37103	1472	89.82	20,41	45.00	✓
H 9500 - 075 - C	H 9500 - 075 - D	75	2.95	305	12.01	230	9.06			14270	32081	17042	38311	1663	101.48	21,17	46.67	✓
H 9500 - 080 - C	H 9500 - 080 - D	80	3.15	315	12.40	235	9.25			14394	32358	17238	38752	1743	106.34	21,49	47.38	✓
H 9500 - 100 - C	H 9500 - 100 - D	100	3.94	355	13.98	255	10.04			14806	33285	17896	40232	2061	125.78	22,76	50.18	✓
H 9500 - 125 - C	H 9500 - 125 - D	125	4.92	405	15.94	280	11.02			15189	34147	18515	41622	2459	150.07	24,35	53.68	✓
H 9500 - 150 - C	H 9500 - 150 - D	150	5.91	455	17.91	305	12.01			15478	34795	18983	42674	2857	174.36	25,94	57.19	✓
H 9500 - 160 - C	H 9500 - 160 - D	160	6.30	475	18.70	315	12.40			15574	35012	19139	43027	3017	184.08	26,58	58.60	✓
H 9500 - 175 - C	H 9500 - 175 - D	175	6.89	505	19.88	330	12.99			15702	35300	19349	43498	3255	198.66	27,53	60.69	✓
H 9500 - 200 - C	H 9500 - 200 - D	200	7.87	555	21.85	355	13.98			15882	35704	19644	44161	3654	222.96	29,12	64.20	✓
H 9500 - 250 - C	H 9500 - 250 - D	250	9.84	655	25.79	405	15.94			16152	36311	20088	45161	4450	271.54	32,30	71.21	✓
H 9500 - 300 - C	H 9500 - 300 - D	300	11.81	755	29.72	455	17.91			16345	36746	20408	45879	5246	320.13	35,47	78.20	✓

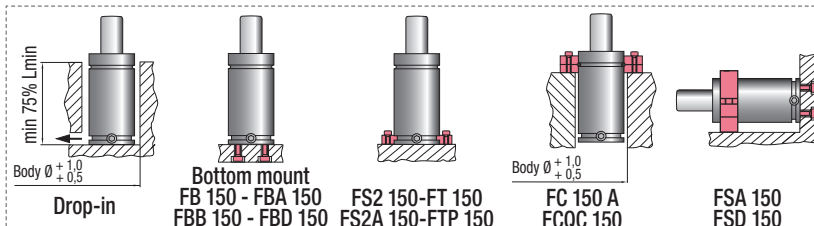

HOW TO ORDER

p. 135

INSTALLATION GUIDELINE

p. 205



OSAS + OSM = **OVER STROKE ACTIVE SAFETY** + **OVER STROKE MARKER**

ACTIVE SAFETY

Il nuovo codice sarà fornito solo ad esaurimento del vecchio

The new code will be supplied only when the old will be out of stock

Der neue Kode wird nur angegeben, wenn der alte nicht mehr lieferbar ist

Le nouveau code sera fourni uniquement lorsque le vieux stock sera écoulé

El nuevo código será suministrado sólo cuando se agoten las existencias del antiguo

O novo código irá ser fornecido apenas quando o antigo esgotar stock



OSAS



USAS



OPAS

easu MANIFOLD p. 247

* F_{1i} = Isothermal end force at 100% Cu p. 16

** F_{1p} = Polytropic end force at 100% Cu

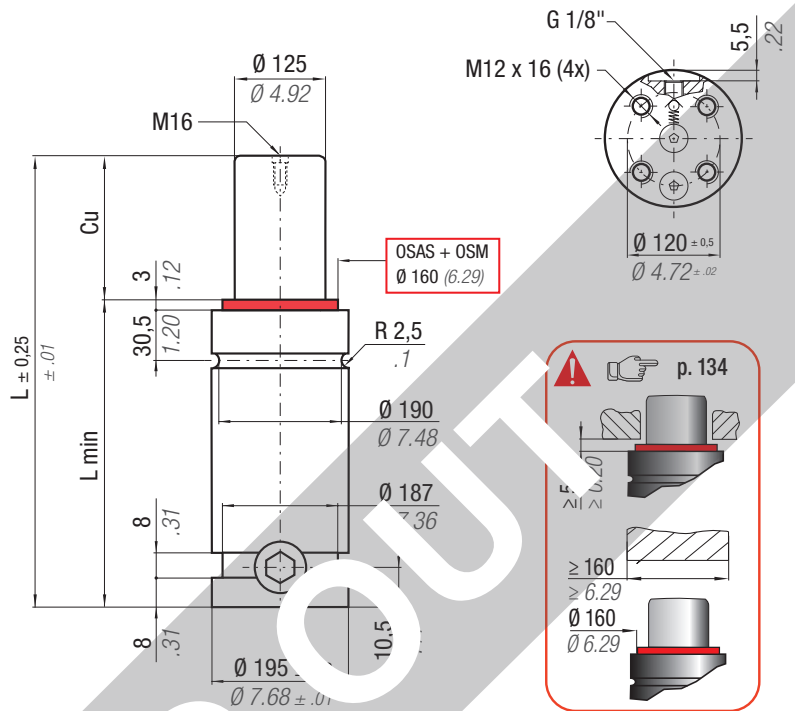

		ΔP	P max	P min	S	SPM	Max Speed	Maintenance kit		
N ₂	0 - 80 °C 32 - 176 °F	± 0,33 %/°C	150 bar 2175 psi	20 bar 290 psi	12,2 19,019 m ²	~ 10 - 70 (at 20°C)	1,8 m/s 70,8 in/s	39BMH18500C		
CODE	NEW	Cu	L	L min	F ₀	F _{1i} *	F _{1p} **	V ₀		
PHASING OUT from 04/2021		mm / inch	mm / inch	mm / inch	daN / lb	daN / lb	daN / lb	cm ³ / in ³	~Kg / ~lb	2014/68/EU
H 18500 - 025 - C	◆ H 18500 - 025 - D	25 / 0.98	211 / 8.27	195 / 7.72	18400 / 41363 ± 5%	23870 / 53662	27205 / 61158	1564 / 95.44	31,06 / 68.48	✓
H 18500 - 038 - C	H 18500 - 038 - D	38 / 1.50	236 / 9.29	195 / 7.80		25611 / 57576	29871 / 67152	1924 / 117.42	32,53 / 71.72	✓
H 18500 - 050 - C	H 18500 - 050 - D	50 / 1.97	260 / 10.24	200 / 8.27		26853 / 60367	31808 / 71508	2257 / 137.72	33,89 / 74.71	✓
H 18500 - 063 - C	H 18500 - 063 - D	63 / 2.48	280 / 11.02	223 / 8.80		27923 / 62774	33503 / 75318	2617 / 159.70	35,36 / 77.96	✓
H 18500 - 075 - C	H 18500 - 075 - D	75 / 2.95	300 / 11.81	235 / 9.25		28728 / 64584	34791 / 78214	2950 / 179.99	36,70 / 80.91	✓
H 18500 - 080 - C	H 18500 - 080 - D	80 / 3.15	300 / 12.60	240 / 9.45		29023 / 65245	35265 / 79280	3088 / 188.44	37,28 / 82.19	✓
H 18500 - 100 - C	H 18500 - 100 - D	100 / 3.94	360 / 14.17	260 / 10.24		30016 / 67478	36876 / 82901	3642 / 222.26	39,54 / 87.17	✓
H 18500 - 125 - C	H 18500 - 125 - D	125 / 4.92	410 / 16.14	285 / 11.22		30954 / 69587	38414 / 86359	4335 / 264.54	42,37 / 93.41	✓
H 18500 - 150 - C	H 18500 - 150 - D	150 / 5.91	460 / 18.11	310 / 12.20		31668 / 71192	39595 / 89014	5028 / 306.81	45,19 / 99.63	✓
H 18500 - 160 - C	H 18500 - 160 - D	160 / 6.30	480 / 18.90	320 / 12.60		+ 20 °C + 68 °F	31908 / 71732	39994 / 89911	5305 / 323.72	46,33 / 102.14
H 18500 - 175 - C	H 18500 - 175 - D	175 / 6.89	510 / 20.08	335 / 13.19	32229 / 72454	40530 / 91116	5721 / 349.09	48,00 / 108.00	✓	
H 18500 - 200 - C	H 18500 - 200 - D	200 / 7.87	560 / 22.05	360 / 14.17	32683 / 73473	41289 / 92821	6413 / 391.36	50,85 / 112.11	✓	
H 18500 - 250 - C	H 18500 - 250 - D	250 / 9.84	660 / 25.98	410 / 16.14	33369 / 75016	42444 / 95418	7799 / 475.91	56,51 / 124.58	✓	
H 18500 - 300 - C	H 18500 - 300 - D	300 / 11.81	760 / 29.92	460 / 18.11	33864 / 76130	43283 / 97303	9184 / 560.45	62,16 / 137.04	✓	

◆ Disposable

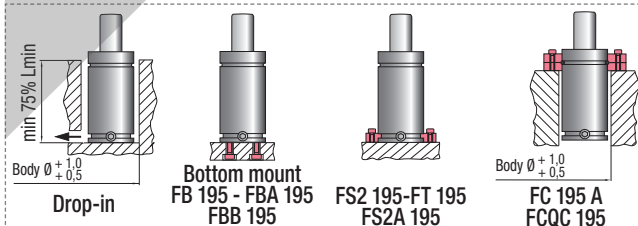

HOW TO ORDER

p. 135

INSTALLATION GUIDELINE

p. 205

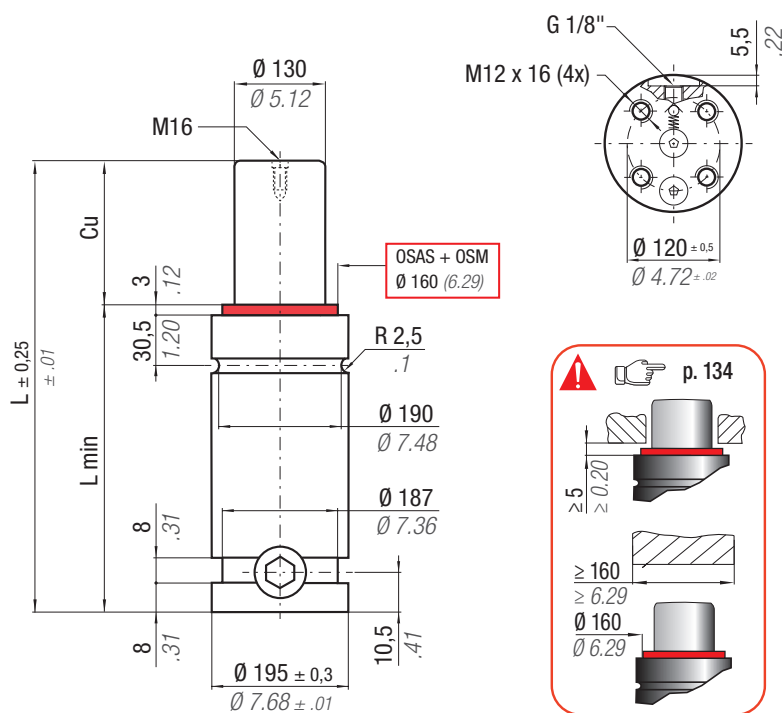

OSAS + OSM = OVER STROKE ACTIVE SAFETY + OVER STROKE MARKER



easys MANIFOLD p. 247

p. 262

ACTIVE SAFETY

* $F_{1i} =$

Isothermal end force at 100% Cu p. 16

** $F_{1p} =$

Polytrophic end force at 100% Cu



OSAS



USAS



OPAS

	$0 - 80^\circ\text{C}$ $32 - 176^\circ\text{F}$	ΔP $\pm 0,33\% / ^\circ\text{C}$	P max 150 bar 2175 psi	P min 20 bar 290 psi	S 132,67 cm ² 20.563 in ²	SPM ~ 10 - 70 (at 20°C)	Max Speed 1,8 m/s 70.8 in/s	Maintenance kit 39BMH20000A
--	----------------------------------------------------	---------------------------------------------	-------------------------------------	-----------------------------------	--------------------------------------------------------------	--------------------------------------	------------------------------------------	---------------------------------------

CODE	Cu		L		L min		F ₀ Initial force		F _{1i} * End force		F _{1p} ** End force		V ₀		PED 2014/68/EU		
	mm	inch	mm	inch	mm	inch	daN	lb	daN	lb	daN	lb	cm ³	in ³	~Kg	~lb	
♦ H 20000 - 025 - A	25	0.98	210	8.27	185	7.28			26635	59878	30667	68942	1530	93,33	31.67	69,82	✓
H 20000 - 038 - A	38	1.50	236	9.29	198	7.80			28821	64792	34054	76556	1888	115,17	33.26	73,33	✓
H 20000 - 050 - A	50	1.97	260	10.24	210	8.27			30393	68326	36541	82147	2219	135,36	34.72	76,54	✓
H 20000 - 063 - A	63	2.50	286	11.30	223	8.80			31757	71393	38734	87077	2577	157,20	36.31	80,05	✓
H 20000 - 075 - A	75	2.95	310	12.20	235	9.25			32787	73708	40411	90848	2907	177,33	37.78	83,29	✓
H 20000 - 080 - A	80	3.15	320	12.60	240	9.45			33165	74558	41031	92241	3045	185,75	38.39	84,64	✓
H 20000 - 100 - A	100	3.94	360	14.17	260	10.24			34444	77433	43145	96994	3596	219,36	40.83	90,01	✓
H 20000 - 125 - A	125	4.92	410	16.14	285	11.22			35658	80162	45176	101560	4285	261,39	43.88	96,74	✓
H 20000 - 150 - A	150	5.91	460	18.11	310	12.20			36586	82249	46744	105085	4974	303,41	46.94	103,48	✓
H 20000 - 160 - A	160	6.30	480	18.90	320	12.60			36899	82952	47276	106281	5249	320,19	48.16	106,17	✓
H 20000 - 175 - A	175	6.89	510	20.56	335	13.19			37319	83896	47991	107888	5663	345,44	49.99	110,21	✓
H 20000 - 200 - A	200	7.87	560	22.05	360	14.17			37911	85227	49005	110168	6352	387,47	53.05	116,96	✓
H 20000 - 250 - A	250	9.84	660	25.98	410	16.14			37448	84186	48211	108383	8056	491,42	56.59	124,76	✓
H 20000 - 300 - A	300	11.81	760	29.92	460	18.11			38068	85580	49274	110772	9482	578,40	62.32	137,39	✓

♦ Disposable

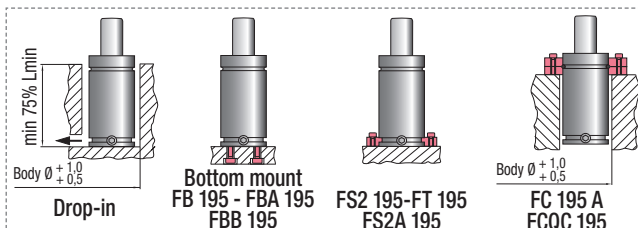

HOW TO ORDER

p. 135

INSTALLATION GUIDELINE

p. 205

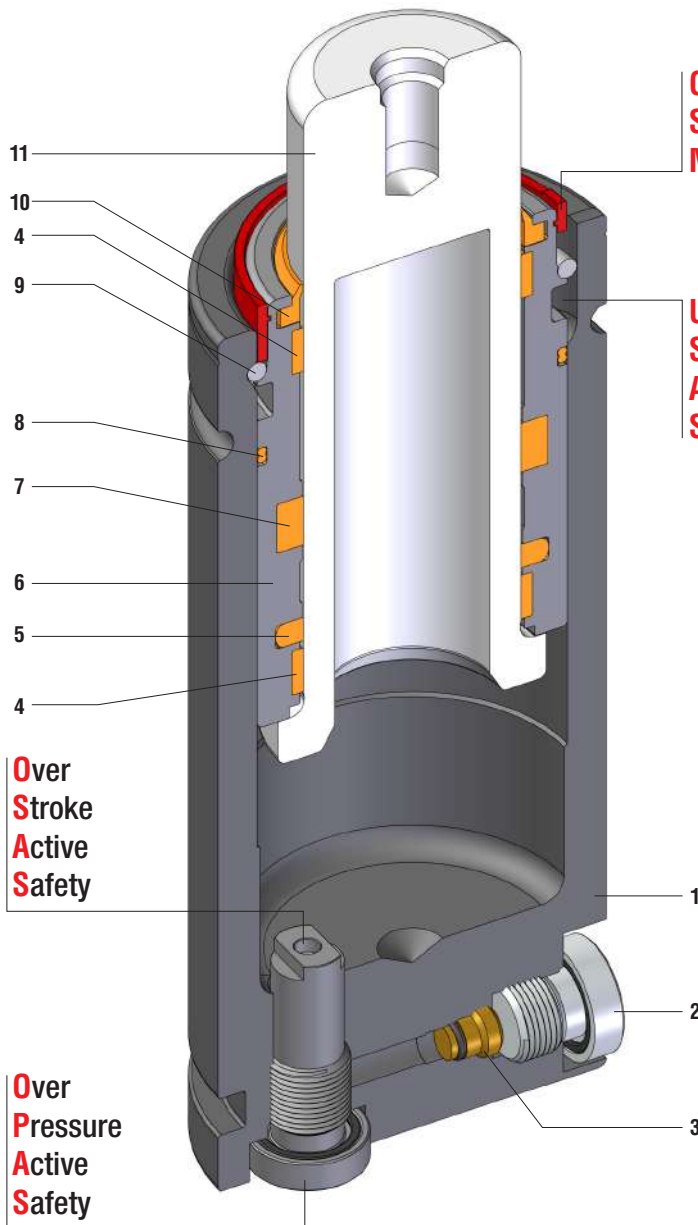

Over Stroke Marker

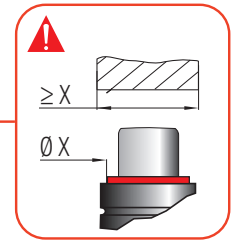

Uncontrolled Speed Active Safety

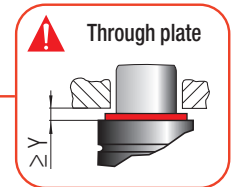

Over Stroke Active Safety

Over Pressure Active Safety

UP to 120°C / 248°F

LONG LIFE thanks to special seals and guides for High Temperature

Per alta temperatura, ISO standard, forza potenziata - For high temperature, ISO standard, high force
 Für Hochtemperatur, ISO Standard, erhöhte Kraft - Pour haute température, standard ISO, force majorée
 Para alta temperatura, ISO standard, fuerza potenciada - De alta temperatura, norma ISO, força permitida

SEALING	ROD SEAL
DESIGN	BUSH - BODY DESIGN

1	Body	5	Rod seal*	9	Retaining ring
2	Plug	6	Bush	10	Rod wiper*
3	Valve	7	Rod seal*	11	Rod (nitrited superfinished)
4	Guide ring*	8	Dual ring seal*		

*special design and materials for high temperature.

RANGE CHART

Model	Body Ø		Stroke Cu		Initial force FO								
	mm	inch	mm	inch	daN	lb	HIGH TEMPERATURE		OSAS	USAS	OPAS	SKUDO	SW
HT 500 T1	38	1.50	10 - 125	0.39 - 4.92	495	1113	✓	-	✓	✓	✓	-	✓
HT 700 T1	45	1.77	10 - 200	0.39 - 7.87	775	1742	✓	-	✓	✓	✓	-	✓
HT 1000 T1	50	1.97	13 - 300	0.51 - 11.81	970	2181	✓	-	✓	✓	✓	-	✓
HT 500 T2	38	1.50	10 - 125	0.39 - 4.92	480	1079	-	✓	✓	✓	✓	-	✓
HT 700 T2	45	1.77	10 - 200	0.39 - 7.87	750	1686	-	✓	✓	✓	✓	-	✓
HT 1000 T2	50	1.97	13 - 300	0.51 - 11.81	940	2113	-	✓	✓	✓	✓	-	✓

✓ Built-in as standard

✓ Optional upon request

T1

Temperatura di esercizio
Working temperature
Betriebstemperatur
Température de fonctionnement
Temperatura de funcionamiento
Temperatura de funcionamiento

P max

80 ÷ 100°C
176 ÷ 212°F

125 bar
1813 psi

T2

Temperatura di esercizio
Working temperature
Betriebstemperatur
Température de fonctionnement
Temperatura de funcionamiento
Temperatura de funcionamiento

P max

100 ÷ 120°C
212 ÷ 248°F

115 bar
1668 psi



HOW TO ORDER

Series _____ Revision code _____

Model **HT1000-010-B-E-W-T1** Working temperature _____

Stroke _____ Version _____

Available versions



HT 1000-010-B-T1/T2
Standard code



Self contained

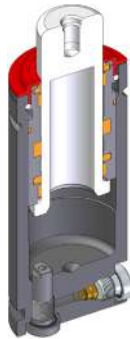

HT 1000-010-B-W-T1/T2
Add "-W" to standard code



Self contained



+ Secondary wiper

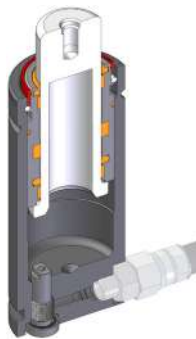

HT 1000-010-B-N-T1/T2
Add "-N" to standard code



Linkable

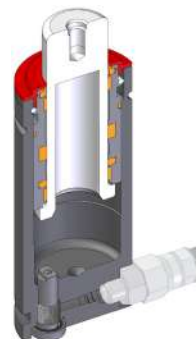

HT 1000-010-B-N-W-T1/T2
Add "-N-W" to standard code



Linkable



+ Secondary wiper



HT 1000-010-B-E-T1/T2
Add "-E" to standard code



Easy Manifold



HT 1000-010-B-E-W-T1/T2
Add "-E-W" to standard code



Easy Manifold



+ Secondary wiper



ACTIVE SAFETY



OSAS + OSM = OVER STROKE ACTIVE SAFETY + OVER STROKE MARKER

Il nuovo codice sarà fornito solo ad esaurimento del vecchio

The new code will be supplied only when the old will be out of stock

Der neue Kode wird nur angegeben, wenn der alte nicht mehr lieferbar ist

Le nouveau code sera fourni uniquement lorsque le vieux stock sera écoulé

El nuevo código será suministrado sólo cuando se agoten las existencias del antiguo

O novo código irá ser fornecido apenas quando o antigo esgotar stock

easU MANIFOLD p. 247

p. 262

* F_{1i} = Isothermal end force at 100% Cu p. 16

** F_{1p} = Polytrophic end force at 100% Cu

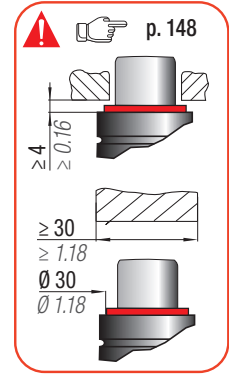
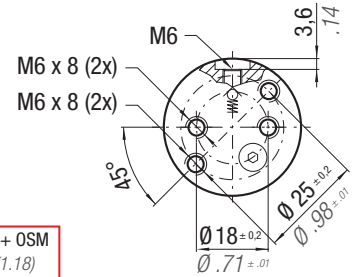
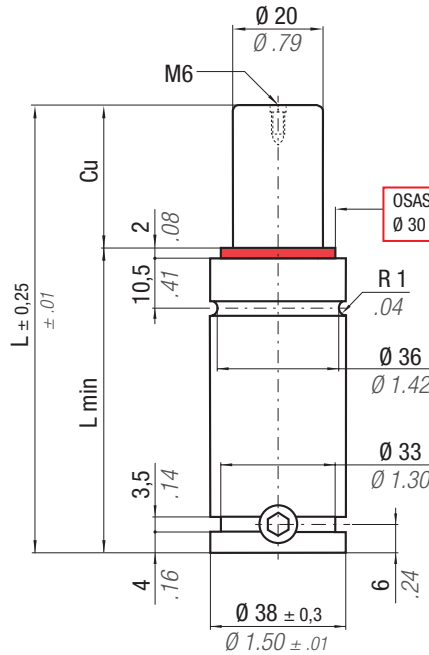

	80 - 100 °C 176 - 212 °F	ΔP ± 0,33 %/°C	P max 125 bar 1813 psi	P min 20 bar 290 psi	S 3,14 cm ² 0,478 in ²	SPM ~ 5 - 20	Max Speed 1 m/s 39,4 in/s	Maintenance kit 39BMMMGS00038B
--	-----------------------------	---------------------------	-------------------------------------	-----------------------------------	-----------------------------------------------------------	------------------------	----------------------------------------	------------------------------------------

CODE PHASING OUT from 04/2021	NEW	Cu		L		L min		F ₀ Initial force daN lb	F _{1i} *		F _{1p} **		V ₀		~Kg ~lb	PED 2014/68/EU	
		mm	inch	mm	inch	mm	inch		daN	lb	daN	lb	cm ³	in ³			
HT 500 - 010 - A - T1	HT 500 - 010 - B - T1	10	0.39	70	2.76	60	2.36	390 877 + 20°C + 68°F 495 1113 + 100°C + 212°F	655	1473	758	1705	14,5	0,88	0,31	0,68	✓
HT 500 - 013 - A - T1	HT 500 - 013 - B - T1	13	0.51	75,7	2.98	62,7	2.47		681	1530	800	1798	16,9	1.03	0,32	0,71	✓
HT 500 - 016 - A - T1	HT 500 - 016 - B - T1	16	0.63	82	3.23	66	2.60		695	1563	823	1851	19,7	1.20	0,34	0,75	✓
HT 500 - 019 - A - T1	HT 500 - 019 - B - T1	19	0.75	88	3.46	69	2.72		692	1556	818	1840	23,6	1.44	0,35	0,77	✓
HT 500 - 025 - A - T1	HT 500 - 025 - B - T1	25	0.98	100	3.94	75	2.95		731	1643	882	1983	27,3	1.67	0,38	0,84	✓
HT 500 - 038 - A - T1	HT 500 - 038 - B - T1	38	1.50	126	4.96	88	3.46		759	1707	930	2091	38,4	2.34	0,44	0,97	✓
HT 500 - 050 - A - T1	HT 500 - 050 - B - T1	50	1.97	150	5.91	100	3.94		775	1742	957	2151	48,6	2.97	0,50	1.10	✓
HT 500 - 063 - A - T1	HT 500 - 063 - B - T1	63	2.48	176,5	6.95	113,5	4.47		783	1761	972	2184	60,0	3.66	0,56	1.23	✓
HT 500 - 080 - A - T1	HT 500 - 080 - B - T1	80	3.15	210	8.27	130	5.12		796	1789	993	2232	74,1	4.52	0,64	1.41	✓
HT 500 - 100 - A - T1	HT 500 - 100 - B - T1	100	3.94	250	9.84	150	5.91		804	1806	1006	2262	91,2	5.57	0,73	1.61	✓
HT 500 - 125 - A - T1	HT 500 - 125 - B - T1	125	4.92	300	11.81	175	6.89		811	1823	1019	2291	112,3	6.85	0,85	1.87	✓

◆ Disposable

End force at 100°C / 212°F

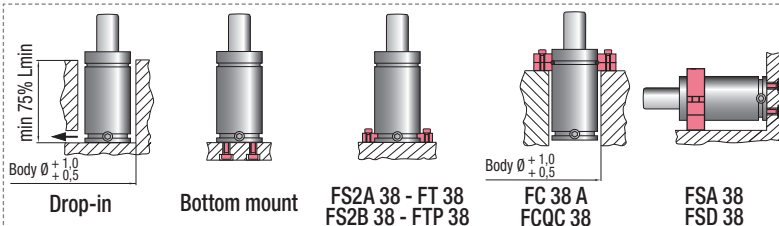

HOW TO ORDER

p. 149

INSTALLATION GUIDELINE

p. 205

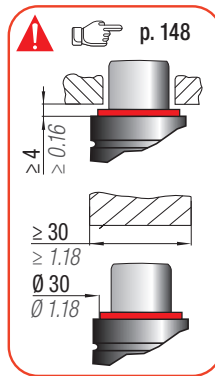
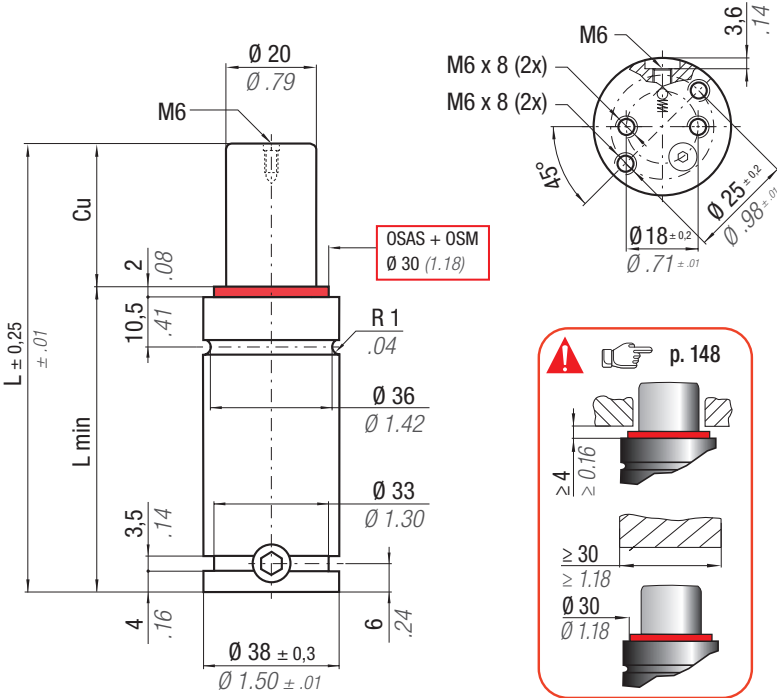

OSAS + OSM = OVER STROKE ACTIVE SAFETY + OVER STROKE MARKER

Il nuovo codice sarà fornito solo ad esaurimento del vecchio

The new code will be supplied only when the old will be out of stock

Der neue Kode wird nur angegeben, wenn der alte nicht mehr lieferbar ist

Le nouveau code sera fourni uniquement lorsque le vieux stock sera écoulé

El nuevo código será suministrado sólo cuando se agoten las existencias del antiguo

O novo código irá ser fornecido apenas quando o antigo esgotar stock

easu MANIFOLD p. 247

p. 262

* $F_{1i} =$

Isothermal end force at 100% Cu

p. 16

** $F_{1p} =$

Polytrophic end force at 100% Cu



ACTIVE SAFETY



		100 - 120 °C 212 - 248 °F	ΔP $\pm 0,33 \% / ^\circ C$	P max 115 bar 1668 psi	P min 20 bar 290 psi	S 3,14 cm ² 0.487 in ²	SPM ~ 5 - 20	Max Speed 1 m/s 39.4 in/s	Maintenance kit 39BMMMGS00038B
--	--	------------------------------	----------------------------------------	-------------------------------------	-----------------------------------	-----------------------------------------------------------	------------------------	----------------------------------------	------------------------------------------

CODE PHASING OUT from 04/2021	NEW	Cu		L		L min		F ₀ Initial force		F _{1i} * End force *		F _{1p} ** End force **		V ₀		PED 2014/68/EU		
		mm	inch	mm	inch	mm	inch	daN	lb	daN	lb	daN	lb	cm ³	in ³	~Kg	~lb	✓
HT 500 - 010 - A - T2	HT 500 - 010 - B - T2	10	0.39	70	2.76	60	2.36			631	1419	737	1656	14,5	0.88	0,31	0,68	✓
HT 500 - 013 - A - T2	HT 500 - 013 - B - T2	13	0.51	75,7	2.98	62,7	2.47			655	1473	777	1746	16,9	1.03	0,32	0,71	✓
HT 500 - 016 - A - T2	HT 500 - 016 - B - T2	16	0.63	82	3.23	66	2.60	360	809	669	1504	800	1798	19,7	1.20	0,34	0,75	✓
HT 500 - 019 - A - T2	HT 500 - 019 - B - T2	19	0.75	88	3.46	69	2.72			666	1498	795	1787	23,6	1.44	0,35	0,77	✓
HT 500 - 025 - A - T2	HT 500 - 025 - B - T2	25	0.98	100	3.94	75	2.95			703	1579	857	1926	27,3	1.67	0,38	0,84	✓
HT 500 - 038 - A - T2	HT 500 - 038 - B - T2	38	1.50	126	4.96	88	3.46			729	1640	903	2031	38,4	2.34	0,44	0,97	✓
HT 500 - 050 - A - T2	HT 500 - 050 - B - T2	50	1.97	150	5.91	100	3.94	480	1079	744	1673	929	2089	48,6	2.97	0,50	1.10	✓
HT 500 - 063 - A - T2	HT 500 - 063 - B - T2	63	2.48	176,5	6.95	113,5	4.47			752	1691	944	2121	60,0	3.66	0,56	1.23	✓
HT 500 - 080 - A - T2	HT 500 - 080 - B - T2	80	3.15	210	8.27	130	5.12			764	1718	964	2168	74,1	4.52	0,64	1.41	✓
HT 500 - 100 - A - T2	HT 500 - 100 - B - T2	100	3.94	250	9.84	150	5.91			771	1734	977	2198	91,2	5.57	0,73	1.61	✓
HT 500 - 125 - A - T2	HT 500 - 125 - B - T2	125	4.92	300	11.81	175	6.89			778	1749	990	2225	112,3	6.85	0,85	1.87	✓

◆ Disposable

End force at 120°C / 248°F

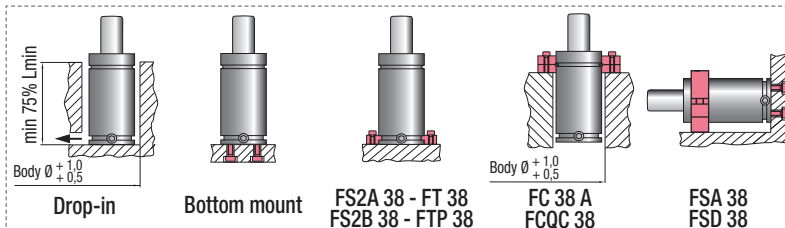

HOW TO ORDER

p. 149

INSTALLATION GUIDELINE

p. 205

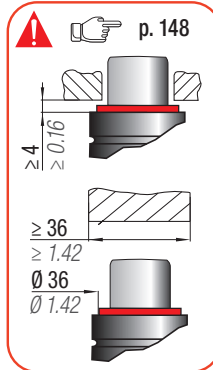
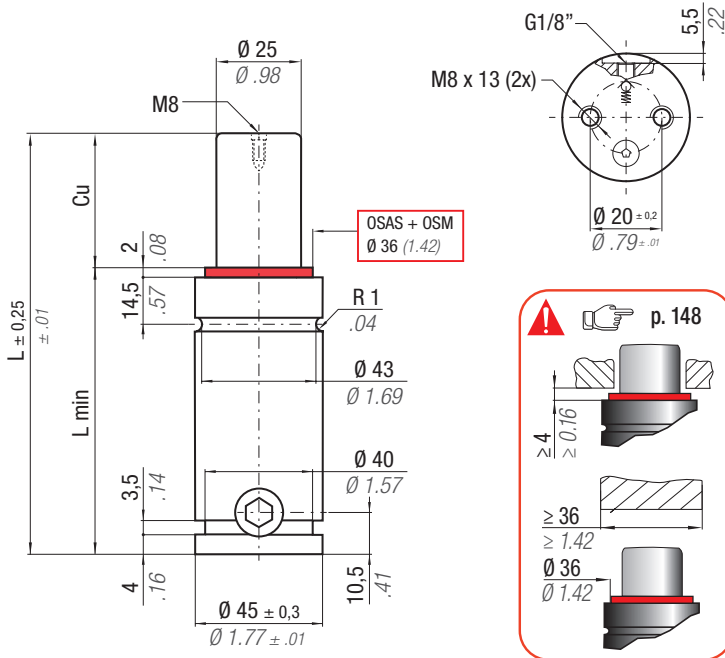

OSAS + OSM = OVER STROKE ACTIVE SAFETY + OVER STROKE MARKER

Il nuovo codice sarà fornito solo ad esaurimento del vecchio

The new code will be supplied only when the old will be out of stock

Der neue Kode wird nur angegeben, wenn der alte nicht mehr lieferbar ist

Le nouveau code sera fourni uniquement lorsque le vieux stock sera épuisé

El nuevo código será suministrado sólo cuando se agoten las existencias del antiguo

O novo código irá ser fornecido apenas quando o antigo esgotar stock

easu MANIFOLD p. 247

p. 262

* $F_{1i} =$

Isothermal end force at 100% Cu p. 16

** $F_{1p} =$

Polytrophic end force at 100% Cu



ACTIVE SAFETY



	100 - 120 °C 212 - 248 °F	ΔP ± 0,33 %/°C	P max 115 bar 1668 psi	P min 20 bar 290 psi	S 4,91 cm ² 0.761 in ²	SPM ~ 5 - 20	Max Speed 1 m/s 39.4 in/s	Maintenance kit 39BMMMGS00045B
--	------------------------------	---------------------------	-------------------------------------	-----------------------------------	-----------------------------------------------------------	------------------------	----------------------------------------	------------------------------------------

CODE PHASING OUT from 04/2021	NEW	Cu		L		L min		F0 Initial force		F1i * End force *		F1p ** End force **		V0		PED 2014/68/EU		
		mm	inch	mm	inch	mm	inch	daN	lb	daN	lb	daN	lb	cm ³	in ³	~Kg	~lb	✓
HT 700 - 010 - A - T2	HT 700 - 010 - B - T2	10	0.39	105	4.13	95	3.74			970	2181	1125	2528	24,0	1.46	0,90	1.98	✓
HT 700 - 013 - A - T2	HT 700 - 013 - B - T2	13	0.50	110,7	4.35	97,7	3.85			1011	2273	1192	2680	27,4	1.67	0,91	2.01	✓
HT 700 - 025 - A - T2	HT 700 - 025 - B - T2	25	0.98	135	5.31	110	4.33	565	1270	1103	2479	1347	3029	42,2	2.58	1,00	2.20	✓
HT 700 - 038 - A - T2	HT 700 - 038 - B - T2	38	1.50	161	6.34	123	4.84	+ 20°C		1159	2605	1445	3249	58,1	3.55	1,09	2.40	✓
HT 700 - 050 - A - T2	HT 700 - 050 - B - T2	50	1.97	185	7.28	135	5.31	+ 68°F		1191	2678	1503	3378	72,7	4.44	1,17	2.58	✓
HT 700 - 063 - A - T2	HT 700 - 063 - B - T2	63	2.48	211,5	8.33	148,5	5.85			1211	2723	1539	3459	89,0	5.43	1,26	2.78	✓
HT 700 - 080 - A - T2	HT 700 - 080 - B - T2	80	3.15	245	9.65	165	6.50	750	1686	1237	2781	1585	3563	109,2	6.66	1,37	3.02	✓
HT 700 - 100 - A - T2	HT 700 - 100 - B - T2	100	3.94	285	11.22	185	7.28	+ 120°C		1255	2820	1616	3634	133,5	8.15	1,51	3.33	✓
HT 700 - 125 - A - T2	HT 700 - 125 - B - T2	125	4.92	335	13.19	210	8.27	+ 248°F		1270	2854	1644	3695	163,9	10.00	1,67	3.68	✓
HT 700 - 160 - A - T2	HT 700 - 160 - B - T2	160	6.30	405	15.94	245	9.65			1283	2885	1669	3752	206,5	12.60	1,91	4.21	✓
HT 700 - 200 - A - T2	HT 700 - 200 - B - T2	200	7.87	485	19.09	285	11.22			1294	2908	1688	3794	255,2	15.57	2,20	4.85	✓

◆ Disposable

End force at 120°C / 248°F

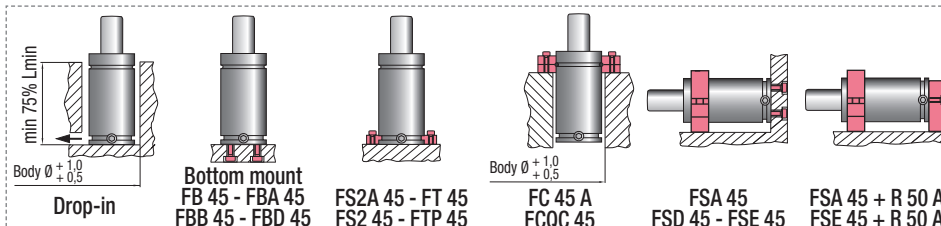

HOW TO ORDER

p. 149

INSTALLATION GUIDELINE

p. 205

HT 1000 T1

80 ÷ 100°C / 176 ÷ 212°F



OSAS + OSM = OVER STROKE ACTIVE SAFETY + OVER STROKE MARKER



HIGH TEMP.

ACTIVE SAFETY



OSAS



USAS



OPAS

Il nuovo codice sarà fornito solo ad esaurimento del vecchio
The new code will be supplied only when the old will be out of stock

Der neue Kode wird nur angegeben, wenn der alte nicht mehr lieferbar ist

Le nouveau code sera fourni uniquement lorsque le vieux stock sera écoulé

El nuevo código será suministrado sólo cuando se agoten las existencias del antiguo

O novo código irá ser fornecido apenas quando o antigo esgotar stock

easu MANIFOLD p. 247

p. 262

* F_{1i} = Isothermal end force at 100% Cu p. 16

** F_{1p} = Polytropic end force at 100% Cu

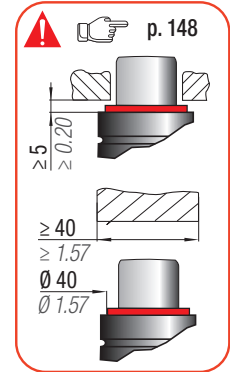
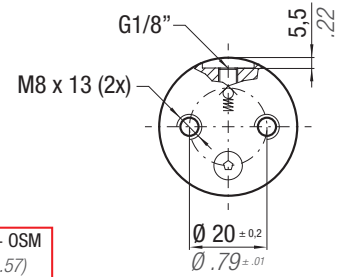
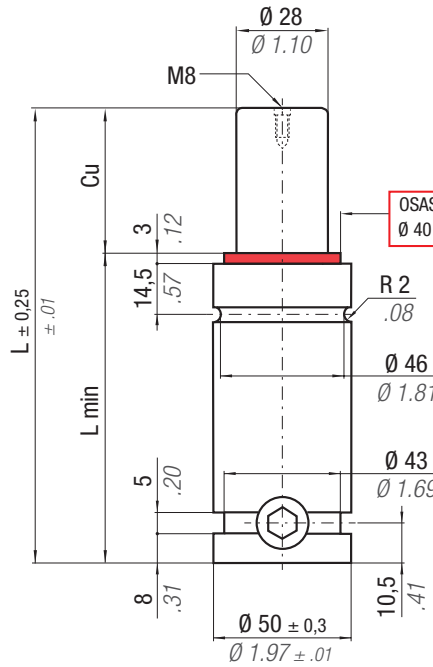

N ₂	80 - 100 °C 176 - 212 °F	ΔP ± 0,33 %/°C	P max 125 bar 1813 psi	P min 20 bar 290 psi	S 6,15 cm ² 0,953 in ²	SPM ~ 5 - 20	Max Speed 1 m/s 39.4 in/s	Maintenance kit 39BMHT01000A
----------------	-----------------------------	---------------------------	------------------------------	----------------------------	----------------------------------------------------	-----------------	---------------------------------	---------------------------------

CODE PHASING OUT from 04/2021	NEW	Cu		L		L min		F ₀		F _{1i} *		F _{1p} **		V ₀		~Kg	~lb	PED 2014/68/EU																																																																																																																														
		mm	inch	mm	inch	mm	inch	daN	lb	daN	lb	daN	lb	cm ³	in ³																																																																																																																																	
HT 1000-013-A-T1	HT 1000-013-B-T1	13	0.50	120,7	4.74	107,7	4.24	770 1731 + 20°C + 68°F	1252	2814	1435	3225	40	2.47	1,21	2.67	✓																																																																																																																															
HT 1000-025-A-T1	HT 1000-025-B-T1	25	0.98	145	5.71	120	4.72											970 2181 + 100°C + 212°F	1373	3088	1632	3668	59	3.60	1,32	2.91	✓																																																																																																																					
HT 1000-038-A-T1	HT 1000-038-B-T1	38	1.50	171	6.73	133	5.24																					1454	3269	1766	3970	79	4.81	1,43	3.15	✓																																																																																																												
HT 1000-050-A-T1	HT 1000-050-B-T1	50	1.97	195	7.68	145	5.71																														1503	3380	1850	4158	97	5.92	1,53	3.37	✓																																																																																																			
HT 1000-063-A-T1	HT 1000-063-B-T1	63	2.48	221	8.74	158	6.22																																							1542	3465	1915	4305	117	7.13	1,64	3.62	✓																																																																																										
HT 1000-075-A-T1	HT 1000-075-B-T1	75	2.95	245	9.65	170	6.69																																																1568	3525	1960	4407	135	8.24	1,74	3.84	✓																																																																																	
HT 1000-080-A-T1	HT 1000-080-B-T1	80	3.15	255	10.04	175	6.89																																																									1577	3545	1976	4442	143	8.70	1,78	3.92	✓																																																																								
HT 1000-100-A-T1	HT 1000-100-B-T1	100	3.94	295	11.61	195	7.68																																																																		1606	3611	2027	4557	173	10.56	1,96	4.32	✓																																																															
HT 1000-125-A-T1	HT 1000-125-B-T1	125	4.92	345	13.58	220	8.66																																																																											1632	3668	2072	4657	211	12.88	2,17	4.78	✓																																																						
HT 1000-150-A-T1	HT 1000-150-B-T1	150	5.91	395	15.55	245	9.65																																																																																				1650	3709	2104	4729	249	15.20	2,38	5.25	✓																																													
HT 1000-160-A-T1	HT 1000-160-B-T1	160	6.30	415	16.34	255	10.04																																																																																													1656	3722	2114	4753	264	16.13	2,46	5.42	✓																																				
HT 1000-175-A-T1	HT 1000-175-B-T1	175	6.89	445	17.52	270	10.63																																																																																																						1663	3739	2128	4783	287	17.52	2,59	5.71	✓																											
HT 1000-200-A-T1	HT 1000-200-B-T1	200	7.87	495	19.49	295	11.61																																																																																																															1674	3763	2146	4825	325	19.84	2,79	6.15	✓																		
HT 1000-250-A-T1	HT 1000-250-B-T1	250	9.84	595	23.43	345	13.58																																																																																																																								1689	3797	2174	4887	401	24.48	3,21	7.08	✓									
HT 1000-300-A-T1	HT 1000-300-B-T1	300	11.81	695	27.36	395	15.55																																																																																																																																	1700	3821	2193	4929	477	29.13	3,63	8.00	✓

◆ Disposable

End force at 100°C / 212°F

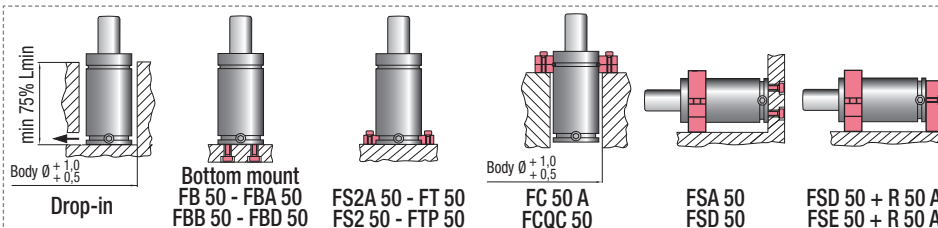

HOW TO ORDER

p. 149

INSTALLATION GUIDELINE

p. 205



ACTIVE SAFETY



OSAS + OSM = OVER STROKE ACTIVE SAFETY + OVER STROKE MARKER

Il nuovo codice sarà fornito solo ad esaurimento del vecchio

The new code will be supplied only when the old will be out of stock

Der neue Kode wird nur angegeben, wenn der alte nicht mehr lieferbar ist

Le nouveau code sera fourni uniquement lorsque le vieux stock sera épuisé

El nuevo código será suministrado sólo cuando se agoten las existencias del antiguo

O novo código irá ser fornecido apenas quando o antigo esgotar stock

easu MANIFOLD p. 247

p. 262

* $F_{1i} =$

Isothermal end force at 100% Cu

p. 16

** $F_{1p} =$

Polytrophic end force at 100% Cu

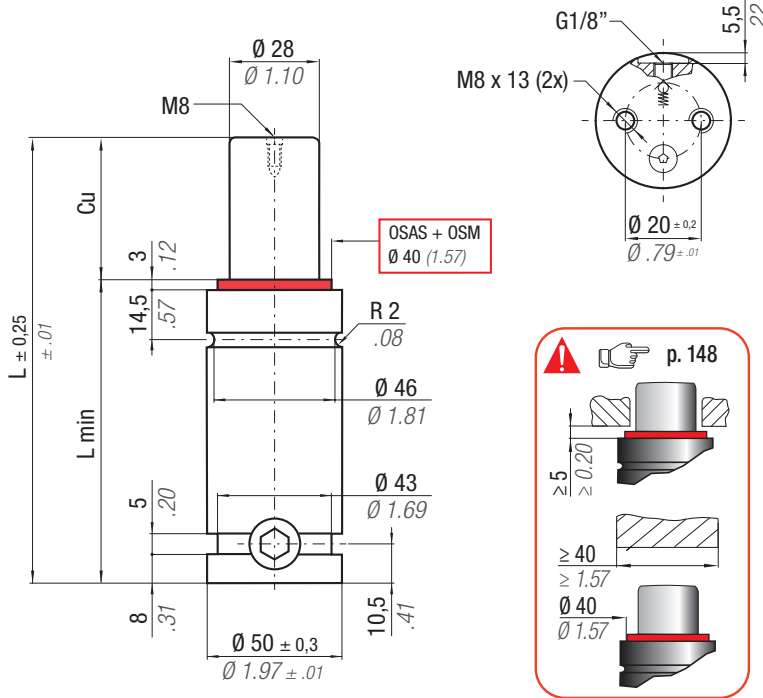

	100 - 120 °C 212 - 248 °F	ΔP ± 0,33 %/°C	P max 115 bar 1668 psi	P min 20 bar 290 psi	S 6,15 cm ² 0.953 in ²	SPM ~ 5 - 20	Max Speed 1 m/s 39.4 in/s	Maintenance kit 39BMT01000A
--	------------------------------	---------------------------	-------------------------------------	-----------------------------------	-----------------------------------------------------------	------------------------	----------------------------------------	---------------------------------------

CODE PHASING OUT from 04/2021	NEW	Cu		L		L min		F0 Initial force		F _{1i} * End force *		F _{1p} ** End force **		V0		PED 2014/68/EU		
		mm	inch	mm	inch	mm	inch	daN	lb	daN	lb	daN	lb	cm ³	in ³	~Kg	~lb	✓
HT 1000-013-A-T2	HT 1000-013-B-T2	13	0.50	120,7	4.74	107,7	4.24			1206	2712	1393	3133	40	2.47	1,21	2.67	✓
HT 1000-025-A-T2	HT 1000-025-B-T2	25	0.98	145	5.71	120	4.72			1322	2971	1585	3563	59	3.60	1,32	2.91	✓
HT 1000-038-A-T2	HT 1000-038-B-T2	38	1.50	171	6.73	133	5.24			1398	3142	1715	3856	79	4.81	1,43	3.15	✓
HT 1000-050-A-T2	HT 1000-050-B-T2	50	1.97	195	7.68	145	5.71			1444	3247	1797	4039	97	5.92	1,53	3.37	✓
HT 1000-063-A-T2	HT 1000-063-B-T2	63	2.48	221	8.74	158	6.22	705	1585	1480	3328	1860	4181	117	7.13	1,64	3.62	✓
HT 1000-075-A-T2	HT 1000-075-B-T2	75	2.95	245	9.65	170	6.69	+ 20°C		1505	3383	1904	4280	135	8.24	1,74	3.84	✓
HT 1000-080-A-T2	HT 1000-080-B-T2	80	3.15	255	10.04	175	6.89	+ 68°F		1514	3403	1919	4315	143	8.70	1,78	3.92	✓
HT 1000-100-A-T2	HT 1000-100-B-T2	100	3.94	295	11.61	195	7.68			1541	3465	1969	4426	173	10.56	1,96	4.32	✓
HT 1000-125-A-T2	HT 1000-125-B-T2	125	4.92	345	13.58	220	8.66	940	2113	1565	3519	2012	4524	211	12.88	2,17	4.78	✓
HT 1000-150-A-T2	HT 1000-150-B-T2	150	5.91	395	15.55	245	9.65	+ 120°C		1582	3557	2043	4593	249	15.20	2,38	5.25	✓
HT 1000-160-A-T2	HT 1000-160-B-T2	160	6.30	415	16.34	255	10.04	+ 248°F		1588	3570	2053	4616	264	16.13	2,46	5.42	✓
HT 1000-175-A-T2	HT 1000-175-B-T2	175	6.89	445	17.52	270	10.63			1595	3586	2067	4646	287	17.52	2,59	5.71	✓
HT 1000-200-A-T2	HT 1000-200-B-T2	200	7.87	495	19.49	295	11.61			1605	3608	2085	4687	325	19.84	2,79	6.15	✓
HT 1000-250-A-T2	HT 1000-250-B-T2	250	9.84	595	23.43	345	13.58			1619	3641	2111	4746	401	24.48	3,21	7.08	✓
HT 1000-300-A-T2	HT 1000-300-B-T2	300	11.81	695	27.36	395	15.55			1629	3663	2130	4788	477	29.13	3,63	8.00	✓

◆ Disposable

End force at 120°C / 248°F

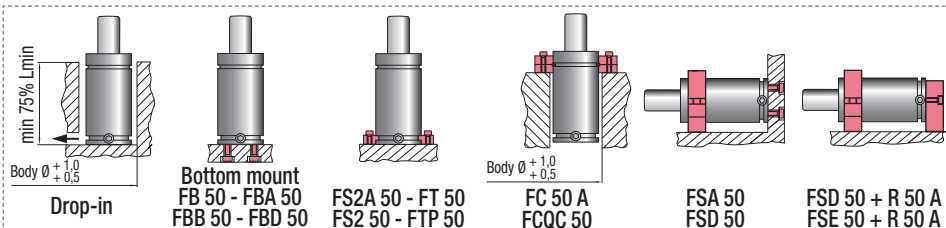

HOW TO ORDER

p. 149

INSTALLATION GUIDELINE

p. 205

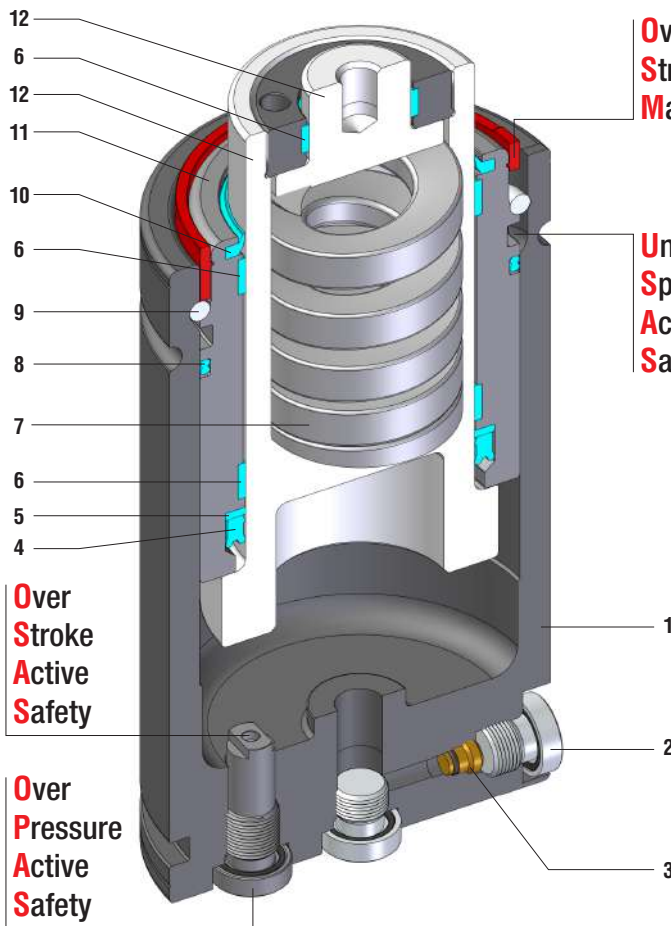

Over Stroke Marker

Uncontrolled Speed Active Safety

Over Stroke Active Safety

Over Pressure Active Safety

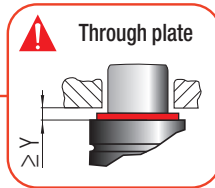
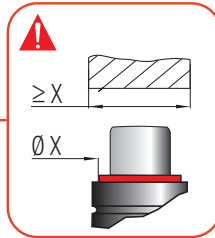

INITIAL IMPACT VIBRATIONS

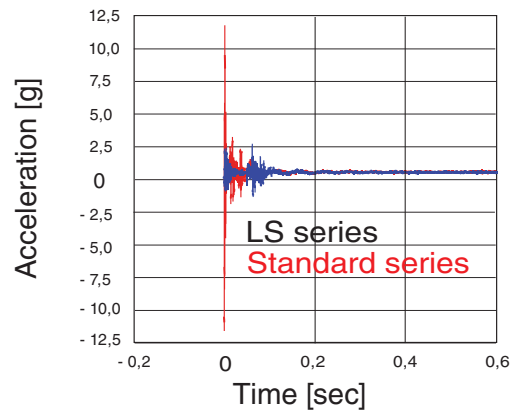

FORCE CURVE

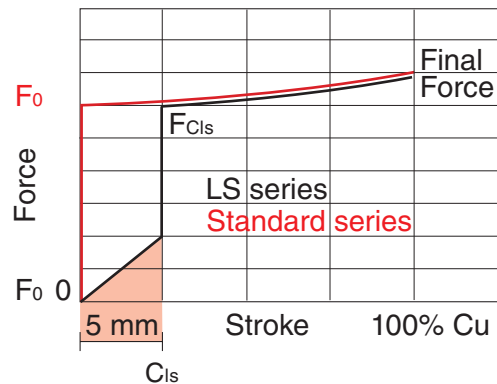

- 55 % noise
- 50 % vibrations

Forza iniziale nulla - Zero force on contact - Ausgangsleistung null
Force iniziale nulle - Fuerza inicial cero - Força inicial nula

SEALING	ROD SEAL
DESIGN	BUSH - BODY DESIGN

1	Body	5	Back-up ring	9	Retaining ring
2	Plug	6	Guide ring	10	Rod wiper
3	Valve	7	Spring	11	Bush
4	Rod seal	8	Dual ring seal	12	Rod (nitrited superfinished)

RANGE CHART

Model	Body Ø		Stroke Cu		Initial force F0						
	mm	inch	mm	inch	daN	lb	OSAS	USAS	OPAS	SKUDO	SW
LS 1500	75	2.95	25 - 300	0.98 - 11.81	1590	3574	✓	✓	✓	-	-
LS 2400	75	2.95	25 - 300	0.98 - 11.81	2385	5362	✓	✓	✓	-	-
LS 3000	95	3.74	25 - 300	0.98 - 11.81	2830	6362	✓	✓	✓	-	-
LS 4200	95	3.74	25 - 300	0.98 - 11.81	4240	9532	✓	✓	✓	-	-
LS 5000	120	4.72	25 - 300	0.98 - 11.81	4418	9932	✓	✓	✓	-	-
LS 6600	120	4.72	25 - 300	0.98 - 11.81	6630	14905	✓	✓	✓	-	-
LS 7500	150	5.91	25 - 300	0.98 - 11.81	7630	17152	✓	✓	✓	-	-
LS 9500	150	5.91	25 - 300	0.98 - 11.81	9540	21446	✓	✓	✓	-	-

✓ Built-in as standard

✓ Optional upon request

HOW TO ORDER



Available versions

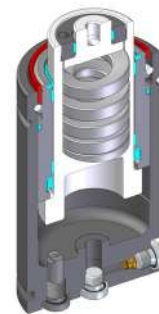

LS 7500-050-C
Standard code



Self contained

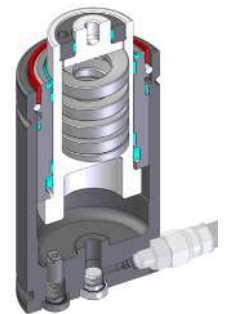

LS 7500-050-C-N
Add "-N" to standard code



Linkable

ACTIVE SAFETY



OSAS



USAS



OPAS

Il nuovo codice sarà fornito solo ad esaurimento del vecchio

The new code will be supplied only when the old will be out of stock

Der neue Kode wird nur angegeben, wenn der alte nicht mehr lieferbar ist

Le nouveau code sera fourni uniquement lorsque le vieux stock sera éoulé

El nuevo código será suministrado sólo cuando se agoten las existencias del antiguo

O novo código irá ser fornecido apenas quando o antigo esgotar stock



p. 262

* $F_{1i} =$

Isothermal end force at 100% Cu



p. 16

** $F_{1p} =$

Polytropic end force at 100% Cu

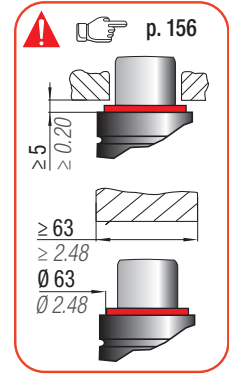
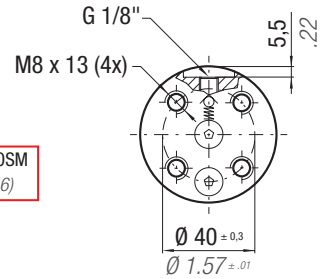
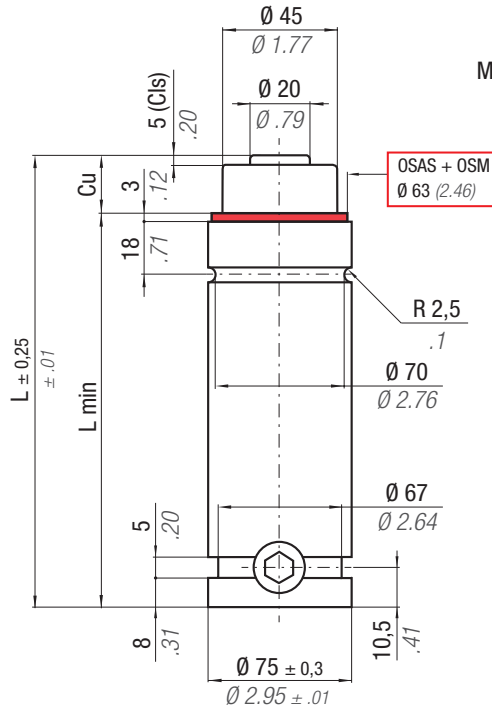

N ₂		0 - 80 °C 32 - 176 °F	ΔP ± 0,33 %/°C	P max 100 bar 1450 psi	P min 20 bar 290 psi	S 15,90 cm ² 2.465 in ²	SPM ~ 15 - 60 (at 20°C)	Max Speed 1,8 m/s 70.8 in/s	Maintenance kit 39BMLS01500B		
CODE	NEW	Cu	L	L min	F ₀	F Cls	F _{1i} *	F _{1p} **	V ₀		PED
PHASING OUT from 04/2021		mm inch	mm inch	mm inch	Initial force daN lb	daN lb	daN lb	daN lb	cm ³ in ³	~Kg ~lb	2014/68/EU
LS 1500 - 025 - A	LS 1500 - 025 - B	25 0.98	160 6.30	135 5.31			2322 5220	2890 6497	108 6.61	3,55 7.83	✓
LS 1500 - 038 - A	LS 1500 - 038 - B	38 1.50	186 7.32	148 5.83			2457 5525	3137 7052	160 9.73	3,77 8.31	✓
LS 1500 - 050 - A	LS 1500 - 050 - B	50 1.97	210 8.27	160 6.30	0 0	1590 3574	2528 5683	3270 7351	207 12.61	3,96 8.73	✓
LS 1500 - 063 - A	LS 1500 - 063 - B	63,5 2.50	237 9.33	173,5 6.83	± 5%	± 5%	2579 5798	3366 7567	260 15.84	4,18 9.22	✓
LS 1500 - 080 - A	LS 1500 - 080 - B	80 3.15	270 10.63	190 7.48			2621 5892	3445 7745	324 19.80	4,45 9.81	✓
LS 1500 - 100 - A	LS 1500 - 100 - B	100 3.94	310 12.20	210 8.27	100 bar 1450 psi	100 bar 1450 psi	2654 5966	3509 7889	403 24.59	4,80 10.58	✓
LS 1500 - 125 - A	LS 1500 - 125 - B	125 4.92	360 14.17	235 9.25			2682 6029	3561 8005	501 30.58	5,20 11.46	✓
LS 1500 - 160 - A	LS 1500 - 160 - B	160 6.30	430 16.93	270 10.63	+ 20 °C +68 °F	+ 20 °C +68 °F	2706 6083	3608 8111	639 38.98	5,77 12.72	✓
LS 1500 - 200 - A	LS 1500 - 200 - B	200 7.87	510 20.08	310 12.20			2725 6126	3644 8192	796 48.56	6,42 14.15	✓
LS 1500 - 250 - A	LS 1500 - 250 - B	250 9.84	610 24.02	360 14.17			2739 6158	3673 8257	992 60.54	7,24 15.96	✓
LS 1500 - 300 - A	LS 1500 - 300 - B	300 11.81	710 27.95	410 16.14			2749 6180	3692 8300	1188 72.52	8,05 17.75	✓

◆ Disposable



HOW TO ORDER

Icon p. 157

INSTALLATION GUIDELINE

Icon p. 205

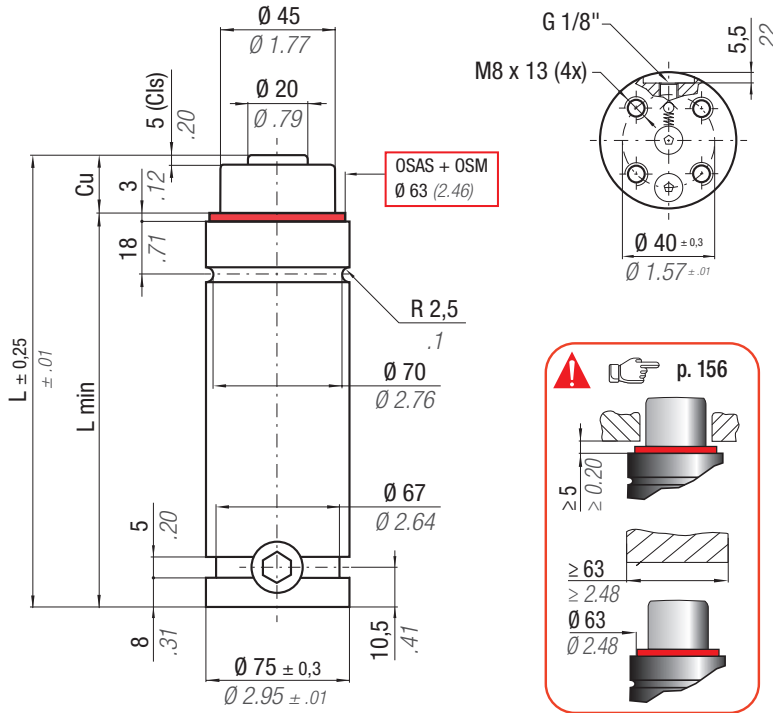

Il nuovo codice sarà fornito solo ad esaurimento del vecchio

The new code will be supplied only when the old will be out of stock

Der neue Kode wird nur angegeben, wenn der alte nicht mehr lieferbar ist

Le nouveau code sera fourni uniquement lorsque le vieux stock sera écoulé

El nuevo código será suministrado sólo cuando se agoten las existencias del antiguo

O novo código irá ser fornecido apenas quando o antigo esgotar stock

ACTIVE SAFETY



OSAS



USAS



OPAS



* F_{1i} =

Isothermal end force at 100% Cu



** F_{1p} =

Polytrophic end force at 100% Cu



N ₂		0 - 80 °C 32 - 176 °F	ΔP ± 0,33 %/°C	P max 150 bar 2175 psi	P min 20 bar 290 psi	S 15,90 cm ² 2.465 in ²	SPM ~ 15 - 60 (at 20°C)	Max Speed 1,8 m/s 70.8 in/s	Maintenance kit 39BMLS01500B		
CODE	NEW	Cu	L	L min	F ₀	F Cls	F _{1i} *	F _{1p} **	V ₀	PED 2014/68/EU	
PHASING OUT from 04/2021		mm inch	mm inch	mm inch	Initial force daN lb	daN lb	End force * daN lb	End force ** daN lb	cm ³ in ³		~Kg ~lb
LS 2400 - 025 - A	LS 2400 - 025 - B	25 0.98	160 6.30	135 5.31			3607 8109	4323 9718	108 6.61	3,55 7,83	✓
LS 2400 - 038 - A	LS 2400 - 038 - B	38 1.50	186 7.32	148 5.83			3836 8624	4692 10548	160 9.73	3,77 8,31	✓
LS 2400 - 050 - A	LS 2400 - 050 - B	50 1.97	210 8.27	160 6.30	0 0	2385 5362	3958 8898	4890 10993	207 12.61	3,96 8,73	✓
LS 2400 - 063 - A	LS 2400 - 063 - B	63,5 2.50	237 9.33	173,5 6.83	± 5%	± 5%	4045 9094	5034 11317	260 15.84	4,18 9,22	✓
LS 2400 - 080 - A	LS 2400 - 080 - B	80 3.15	270 10.63	190 7.48			4116 9253	5152 11582	324 19.80	4,45 9,81	✓
LS 2400 - 100 - A	LS 2400 - 100 - B	100 3.94	310 12.20	210 8.27	150 bar 2175 psi	150 bar 2175 psi	4173 9381	5247 11796	403 24.59	4,80 10,58	✓
LS 2400 - 125 - A	LS 2400 - 125 - B	125 4.92	360 14.17	235 9.25			4221 9489	5326 11973	501 30.58	5,20 11,46	✓
LS 2400 - 160 - A	LS 2400 - 160 - B	160 6.30	430 16.93	270 10.63	+ 20 °C +68 °F	+ 20 °C +68 °F	4263 9584	5396 12131	639 38.98	5,77 12,72	✓
LS 2400 - 200 - A	LS 2400 - 200 - B	200 7.87	510 20.08	310 12.20			4294 9653	5449 12250	796 48.56	6,42 14,15	✓
LS 2400 - 250 - A	LS 2400 - 250 - B	250 9.84	610 24.02	360 14.17			4319 9709	5492 12347	992 60.54	7,24 15,96	✓
LS 2400 - 300 - A	LS 2400 - 300 - B	300 11.81	710 27.95	410 16.14			4336 9748	5521 12412	1188 72.52	8,05 17,75	✓

◆ Disposable

LS

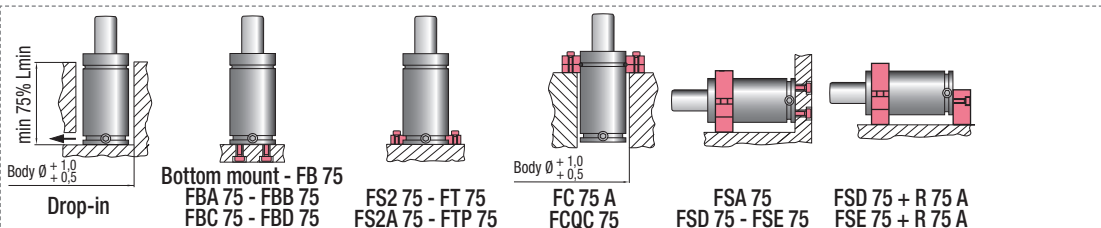

HOW TO ORDER

Icon pointing to p. 157

INSTALLATION GUIDELINE

Icon pointing to p. 205

ACTIVE SAFETY



OSAS



USAS



OPAS

Il nuovo codice sarà fornito solo ad esaurimento del vecchio

The new code will be supplied only when the old will be out of stock

Der neue Kode wird nur angegeben, wenn der alte nicht mehr lieferbar ist

Le nouveau code sera fourni uniquement lorsque le vieux stock sera écoulé

El nuevo código será suministrado sólo cuando se agoten las existencias del antiguo

O novo código irá ser fornecido apenas quando o antigo esgotar stock



p. 262

* F_{1i} =

Isothermal end force at 100% Cu



p. 16

** F_{1p} =

Polytropic end force at 100% Cu

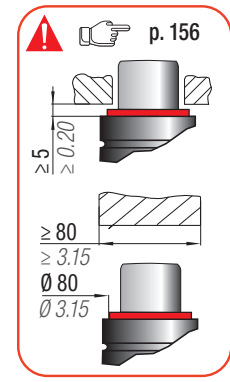
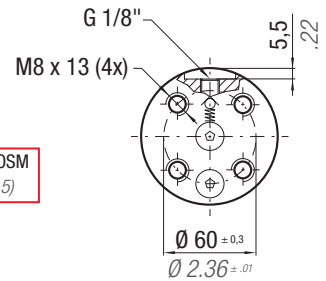
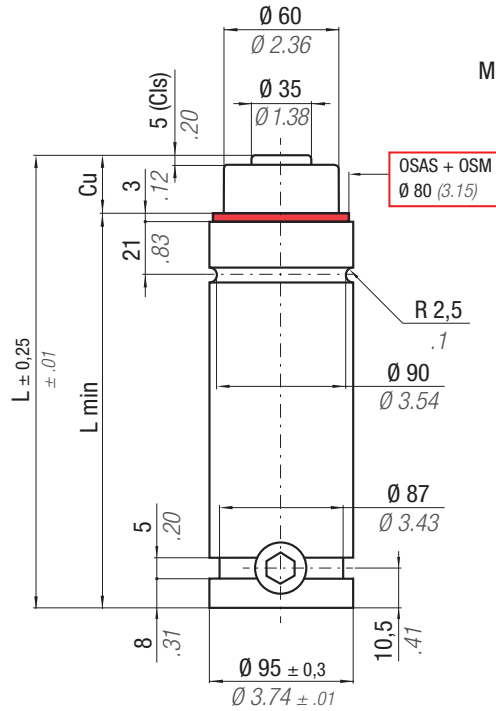

N ₂		0 - 80 °C 32 - 176 °F	ΔP ± 0,33 %/°C	P max 100 bar 1450 psi	P min 20 bar 290 psi	S 28,27 cm ² 4.382 in ²	SPM ~ 15 - 60 (at 20°C)	Max Speed 1,8 m/s 70.8 in/s	Maintenance kit 39BMLS03000B		
CODE	NEW	Cu	L	L min	F ₀	F CIs	F _{1i} *	F _{1p} **	V ₀		PED 2014/68/EU
PHASING OUT from 04/2021		mm inch	mm inch	mm inch	Initial force daN lb	daN lb	End force * daN lb	End force ** daN lb	cm ³ in ³	~Kg ~lb	
LS 3000 - 025 - A	LS 3000 - 025 - B	25 0.98	170 6.69	145 5.71			4066 9141	5027 11301	200 12.17	6,02 13.27	✓
LS 3000 - 038 - A	LS 3000 - 038 - B	38 1.50	196 7.72	158 6.22			4373 9831	5586 12558	283 17.27	6,37 14.04	✓
LS 3000 - 050 - A	LS 3000 - 050 - B	50 1.97	220 8.66	170 6.69	0 0	2830 6362	4548 10224	5912 13292	360 21.97	6,70 14.77	✓
LS 3000 - 063 - A	LS 3000 - 063 - B	63,5 2.50	247 9.72	183,5 7.22	± 5%	± 5%	4681 10522	6164 13858	447 27.26	7,07 15.59	✓
LS 3000 - 080 - A	LS 3000 - 080 - B	80 3.15	280 11.02	200 7.87			4792 10772	6378 14338	553 33.73	7,52 16.58	✓
LS 3000 - 100 - A	LS 3000 - 100 - B	100 3.94	320 12.60	220 8.66	100 bar 1450 psi	100 bar 1450 psi	4884 10979	6556 14739	681 41.57	8,07 17.79	✓
LS 3000 - 125 - A	LS 3000 - 125 - B	125 4.92	370 14.57	245 9.65			4959 11149	6704 15071	842 51.40	8,77 19.33	✓
LS 3000 - 160 - A	LS 3000 - 160 - B	160 6.30	440 17.32	280 11.02	+ 20 °C +68 °F	+ 20 °C +68 °F	5032 11312	6846 15391	1067 65.12	9,73 21.45	✓
LS 3000 - 200 - A	LS 3000 - 200 - B	200 7.87	520 20.47	320 12.60			5086 11433	6953 15630	1324 80.80	10,83 23.88	✓
LS 3000 - 250 - A	LS 3000 - 250 - B	250 9.84	620 24.41	370 14.57			5130 11533	7041 15829	1645 100.39	12,20 26.90	✓
LS 3000 - 300 - A	LS 3000 - 300 - B	300 11.81	720 28.35	420 16.54			5161 11602	7102 15965	1966 119.98	13,57 29.92	✓

◆ Disposable

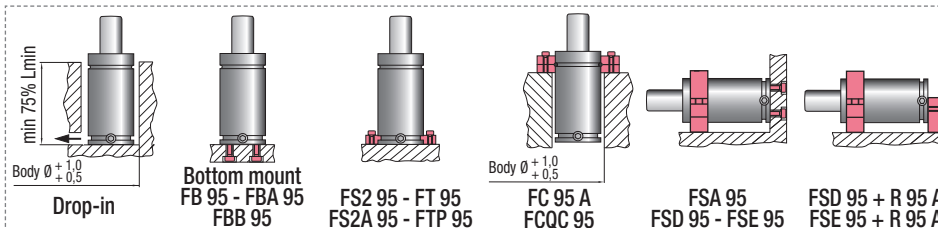

HOW TO ORDER

Icon pointing to page 157

INSTALLATION GUIDELINE

Icon pointing to page 205

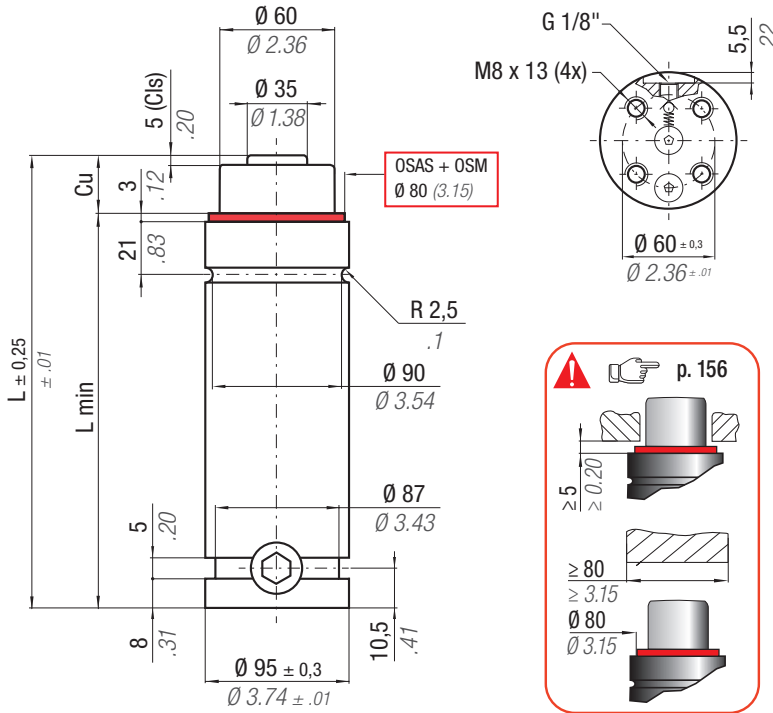

Il nuovo codice sarà fornito solo ad esaurimento del vecchio

The new code will be supplied only when the old will be out of stock

Der neue Kode wird nur angegeben, wenn der alte nicht mehr lieferbar ist

Le nouveau code sera fourni uniquement lorsque le vieux stock sera écoulé

El nuevo código será suministrado sólo cuando se agoten las existencias del antiguo

O novo código irá ser fornecido apenas quando o antigo esgotar stock

ACTIVE SAFETY



OSAS



USAS



OPAS



* $F_{1i} =$

Isothermal end force at 100% Cu



** $F_{1p} =$

Polytrophic end force at 100% Cu



N ₂		0 - 80 °C 32 - 176 °F	ΔP ± 0,33 %/°C	P max 150 bar 2175 psi	P min 20 bar 290 psi	S 28,27 cm ² 4.382 in ²	SPM ~ 15 - 60 (at 20°C)	Max Speed 1,8 m/s 70.8 in/s	Maintenance kit 39BMLS03000B		
CODE	NEW	Cu	L	L min	F ₀	F CIs	F _{1i} *	F _{1p} **	V ₀	PED 2014/68/EU	
PHASING OUT from 04/2021		mm inch	mm inch	mm inch	Initial force daN lb	daN lb	End force * daN lb	End force ** daN lb	cm ³ in ³		
LS 4200 - 025 - A	LS 4200 - 025 - B	25 0.98	170 6.69	145 5.71			6306 14176	7517 16898	200 12.17	6,02 13.27	✓
LS 4200 - 038 - A	LS 4200 - 038 - B	38 1.50	196 7.72	158 6.22			6827 15348	8352 18777	283 17.27	6,37 14.04	✓
LS 4200 - 050 - A	LS 4200 - 050 - B	50 1.97	220 8.66	170 6.69	0 0	4240 9532	7126 16019	8840 19874	360 21.97	6,70 14.77	✓
LS 4200 - 063 - A	LS 4200 - 063 - B	63,5 2.50	247 9.72	183,5 7.22	± 5%	± 5%	7353 16530	9217 20721	447 27.26	7,07 15.59	✓
LS 4200 - 080 - A	LS 4200 - 080 - B	80 3.15	280 11.02	200 7.87			7544 16960	9536 21439	553 33.73	7,52 16.58	✓
LS 4200 - 100 - A	LS 4200 - 100 - B	100 3.94	320 12.60	220 8.66	150 bar 2175 psi	150 bar 2175 psi	7703 17316	9803 22039	681 41.57	8,07 17.79	✓
LS 4200 - 125 - A	LS 4200 - 125 - B	125 4.92	370 14.57	245 9.65			7833 17608	10024 22534	842 51.40	8,77 19.33	✓
LS 4200 - 160 - A	LS 4200 - 160 - B	160 6.30	440 17.32	280 11.02	+ 20 °C +68 °F	+ 20 °C +68 °F	7957 17889	10236 23013	1067 65.12	9,73 21.45	✓
LS 4200 - 200 - A	LS 4200 - 200 - B	200 7.87	520 20.47	320 12.60			8051 18099	10396 23371	1324 80.80	10,83 23.88	✓
LS 4200 - 250 - A	LS 4200 - 250 - B	250 9.84	620 24.41	370 14.57			8128 18272	10528 23668	1645 100.39	12,20 26.90	✓
LS 4200 - 300 - A	LS 4200 - 300 - B	300 11.81	720 28.35	420 16.54			8180 18390	10619 23872	1966 119.98	13,57 29.92	✓

◆ Disposable

LS

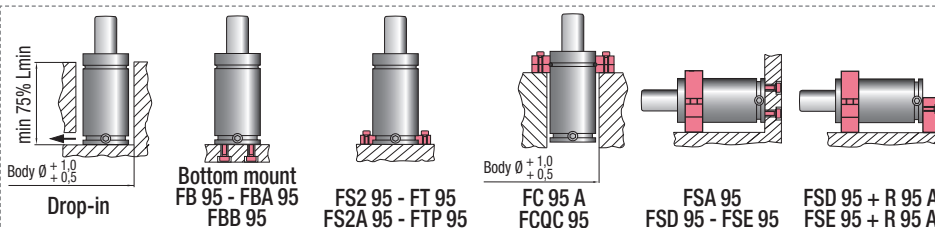

HOW TO ORDER

Icon pointing to p. 157

INSTALLATION GUIDELINE

Icon pointing to p. 205

ACTIVE SAFETY



OSAS



USAS



OPAS

Il nuovo codice sarà fornito solo ad esaurimento del vecchio

The new code will be supplied only when the old will be out of stock

Der neue Kode wird nur angegeben, wenn der alte nicht mehr lieferbar ist

Le nouveau code sera fourni uniquement lorsque le vieux stock sera écoulé

El nuevo código será suministrado sólo cuando se agoten las existencias del antiguo

O novo código irá ser fornecido apenas quando o antigo esgotar stock



p. 262

* $F_{1i} =$

Isothermal end force at 100% Cu



p. 16

** $F_{1p} =$

Polytrophic end force at 100% Cu

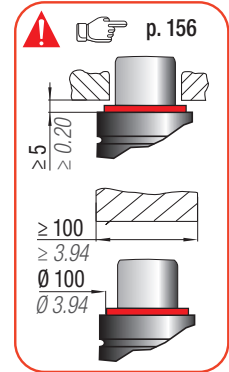
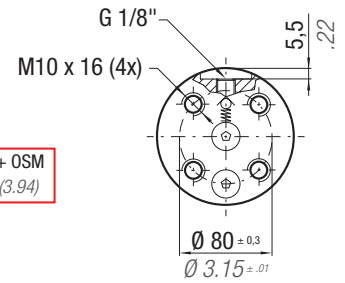
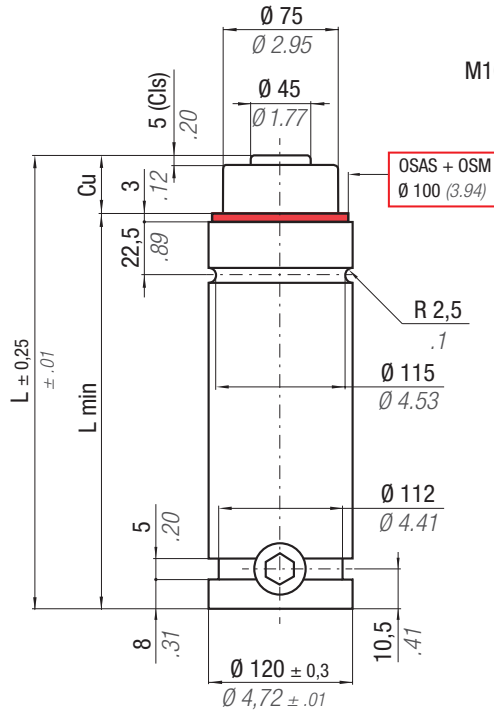

N ₂		0 - 80 °C 32 - 176 °F	ΔP $\pm 0,33 \% / ^\circ C$	P max 100 bar 1450 psi	P min 20 bar 290 psi	S 44,18 cm ² 6.848 in ²	SPM ~ 15 - 60 (at 20°C)	Max Speed 1,8 m/s 70.8 in/s	Maintenance kit 39BMLS05000B		
CODE	NEW	Cu	L	L min	F ₀	F CIs	F _{1i} *	F _{1p} **	V ₀	PED	
PHASING OUT from 04/2021		mm inch	mm inch	mm inch	Initial force daN lb	daN lb	End force * daN lb	End force ** daN lb	cm ³ in ³	~Kg ~lb	2014/68/EU
LS 5000 - 025 - A	LS 5000 - 025 - B	25 0.98	190 7.48	165 6.50			6021 13536	7267 16336	357 21.80	10,60 23.37	✓
LS 5000 - 038 - A	LS 5000 - 038 - B	38 1.50	216 8.50	178 7.01			6537 14695	8185 18401	483 29.47	12,00 26.46	✓
LS 5000 - 050 - A	LS 5000 - 050 - B	50 1.97	240 9.45	190 7.48	0 0	4418 9932	6858 15417	8775 19727	599 36.54	13,20 29.10	✓
LS 5000 - 063 - A	LS 5000 - 063 - B	63,5 2.50	267 10.51	203,5 8.01	$\pm 5\%$	$\pm 5\%$	7118 16002	9261 20819	729 44.50	13,60 29.98	✓
LS 5000 - 080 - A	LS 5000 - 080 - B	80 3.15	300 11.81	220 8.66			7346 16515	9695 21796	889 54.23	14,10 31.09	✓
LS 5000 - 100 - A	LS 5000 - 100 - B	100 3.94	340 13.39	240 9.45	100 bar 1450 psi	100 bar 1450 psi	7544 16959	10075 22650	1082 66.02	15,40 33.95	✓
LS 5000 - 125 - A	LS 5000 - 125 - B	125 4.92	390 15.35	265 10.43			7718 17350	10413 23410	1323 80.76	16,90 37.26	✓
LS 5000 - 160 - A	LS 5000 - 160 - B	160 6.30	460 18.11	300 11.81	+ 20 °C +68 °F	+ 20 °C +68 °F	7883 17722	10738 24140	1662 101.40	18,70 41.23	✓
LS 5000 - 200 - A	LS 5000 - 200 - B	200 7.87	540 21.26	340 13.39			8009 18006	10989 24704	2048 124.98	21,70 47.84	✓
LS 5000 - 250 - A	LS 5000 - 250 - B	250 9.84	640 25.20	390 15.35			8116 18246	11202 25182	2531 154.46	24,80 54.67	✓
LS 5000 - 300 - A	LS 5000 - 300 - B	300 11.81	740 29.13	440 17.32			8190 18412	11350 25516	3014 183.93	28,00 61.73	✓

◆ Disposable

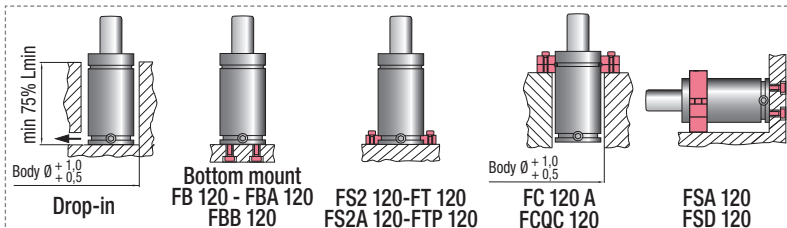

HOW TO ORDER
p. 157

INSTALLATION GUIDELINE
p. 205

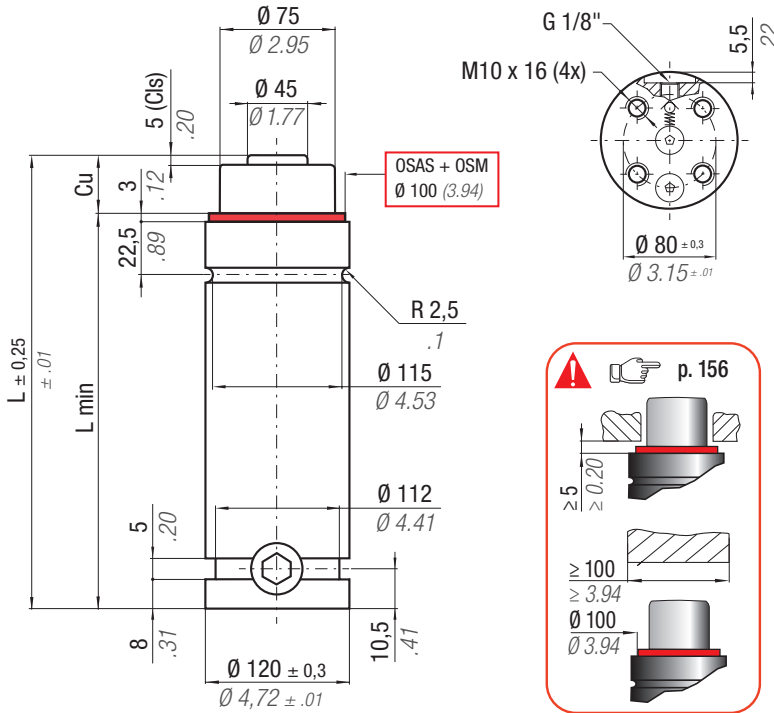

Il nuovo codice sarà fornito solo ad esaurimento del vecchio

The new code will be supplied only when the old will be out of stock

Der neue Kode wird nur angegeben, wenn der alte nicht mehr lieferbar ist

Le nouveau code sera fourni uniquement lorsque le vieux stock sera écoulé

El nuevo código será suministrado sólo cuando se agoten las existencias del antiguo

O novo código irá ser fornecido apenas quando o antigo esgotar stock



* F_{1i} =

Isothermal end force at 100% Cu



** F_{1p} =

Polytrophic end force at 100% Cu

ACTIVE SAFETY



OSAS



USAS



OPAS

		0 - 80 °C 32 - 176 °F	ΔP ± 0,33 %/°C	P max 150 bar 2175 psi	P min 20 bar 290 psi	S 44,18 cm ² 6.848 in ²	SPM ~ 15 - 60 (at 20°C)	Max Speed 1,8 m/s 70.8 in/s	Maintenance kit 39BMLS05000B		
CODE	NEW	Cu	L	L min	F ₀	F Cis	F _{1i} *	F _{1p} **	V ₀		
PHASING OUT from 04/2021		mm inch	mm inch	mm inch	Initial force daN lb	daN lb	End force * daN lb	End force ** daN lb	cm ³ in ³	~Kg ~lb	2014/68/EU
LS 6600 - 025 - A	LS 6600 - 025 - B	25 0.98	190 7.48	165 6.50			9292 20890	10865 24426	357 21.80	10,60 23.37	✓
LS 6600 - 038 - A	LS 6600 - 038 - B	38 1.50	216 8.50	178 7.01			10164 22849	12238 27513	483 29.47	12,00 26.46	✓
LS 6600 - 050 - A	LS 6600 - 050 - B	50 1.97	240 9.45	190 7.48	0 0	6630 14905	10710 24078	13121 29496	599 36.54	13,20 29.10	✓
LS 6600 - 063 - A	LS 6600 - 063 - B	63,5 2.50	267 10.51	203,5 8.01	± 5%	± 5%	11154 25076	13847 31130	729 44.50	13,60 29.98	✓
LS 6600 - 080 - A	LS 6600 - 080 - B	80 3.15	300 11.81	220 8.66			11546 25956	14497 32590	889 54.23	14,10 31.09	✓
LS 6600 - 100 - A	LS 6600 - 100 - B	100 3.94	340 13.39	240 9.45	150 bar 2175 psi	150 bar 2175 psi	11885 26719	15065 33867	1082 66.02	15,40 33.95	✓
LS 6600 - 125 - A	LS 6600 - 125 - B	125 4.92	390 15.35	265 10.43			12185 27392	15571 35004	1323 80.76	16,90 37.26	✓
LS 6600 - 160 - A	LS 6600 - 160 - B	160 6.30	460 18.11	300 11.81	+ 20 °C +68 °F	+ 20 °C +68 °F	12470 28033	16056 36096	1662 101.40	18,70 41.23	✓
LS 6600 - 200 - A	LS 6600 - 200 - B	200 7.87	540 21.26	340 13.39			12688 28524	16431 36938	2048 124.98	21,70 47.84	✓
LS 6600 - 250 - A	LS 6600 - 250 - B	250 9.84	640 25.20	390 15.35			12873 28939	16749 37653	2531 154.46	24,80 54.67	✓
LS 6600 - 300 - A	LS 6600 - 300 - B	300 11.81	740 29.13	440 17.32			13001 29228	16971 38153	3014 183.93	28,00 61.73	✓

◆ Disposable

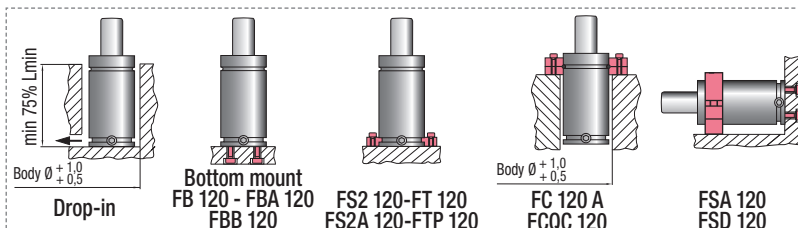

HOW TO ORDER

p. 157

INSTALLATION GUIDELINE

p. 205

Il nuovo codice sarà fornito solo ad esaurimento del vecchio

The new code will be supplied only when the old will be out of stock

Der neue Kode wird nur angegeben, wenn der alte nicht mehr lieferbar ist

Le nouveau code sera fourni uniquement lorsque le vieux stock sera écoulé

El nuevo código será suministrado sólo cuando se agoten las existencias del antiguo

O novo código irá ser fornecido apenas quando o antigo esgotar stock

ACTIVE SAFETY



OSAS



USAS



OPAS



p. 262

* $F_{1i} =$

Isothermal end force at 100% Cu



p. 16

** $F_{1p} =$

Polytropic end force at 100% Cu

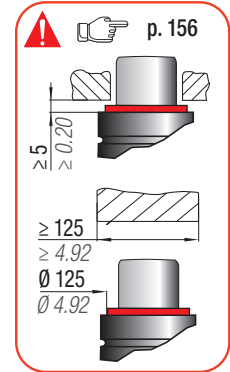
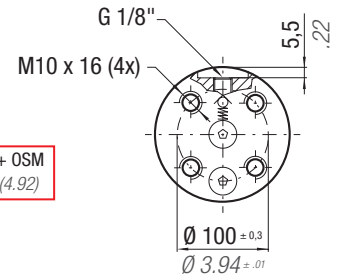
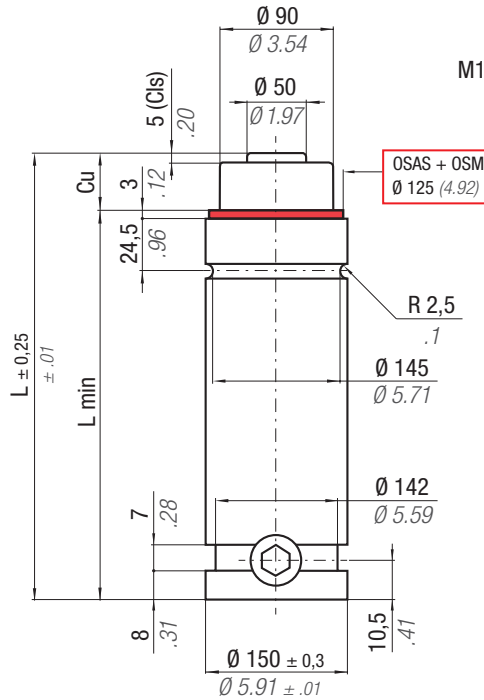

N ₂		0 - 80 °C 32 - 176 °F	ΔP ± 0,33 %/°C	P max 120 bar 1740 psi	P min 20 bar 290 psi	S 63,61 cm ² 9.860 in ²	SPM ~ 15 - 60 (at 20°C)	Max Speed 1,8 m/s 70.8 in/s	Maintenance kit 39BMLS07500A		
CODE	NEW	Cu	L	L min	F ₀	F Cls	F _{1i} *	F _{1p} **	V ₀		PED
PHASING OUT from 04/2021		mm inch	mm inch	mm inch	Initial force daN lb	daN lb	daN lb	daN lb	cm ³ in ³	~Kg ~lb	2014/68/EU
LS 7500 - 025 - B	LS 7500 - 025 - C	25 0.98	205 8.07	180 7.09			9817 22070	11303 25411	638 38.91	19,95 43.98	✓
LS 7500 - 038 - B	LS 7500 - 038 - C	38 1.50	231 9.09	193 7.60			10576 23776	12544 28200	838 51.13	21,15 46.63	✓
LS 7500 - 050 - B	LS 7500 - 050 - C	50 1.97	255 10.04	205 8.07	0 0	7630 17152	11065 24875	13362 30039	1023 62.40	21,95 48.39	✓
LS 7500 - 063 - B	LS 7500 - 063 - C	63,5 2.50	282 11.10	218,5 8.60	± 5%	± 5%	11469 25784	14050 31585	1230 75.08	22,75 50.16	✓
LS 7500 - 080 - B	LS 7500 - 080 - C	80 3.15	315 12.40	235 9.25			11832 26600	14675 32991	1484 90.58	24,55 54.12	✓
LS 7500 - 100 - B	LS 7500 - 100 - C	100 3.94	355 13.98	255 10.04	120 bar 1740 psi	120 bar 1740 psi	12151 27316	15230 34239	1792 109.37	26,25 57.87	✓
LS 7500 - 125 - B	LS 7500 - 125 - C	125 4.92	405 15.94	280 11.02			12435 27956	15732 35366	2177 132.85	28,15 62.06	✓
LS 7500 - 160 - B	LS 7500 - 160 - C	160 6.30	475 18.70	315 12.40	+ 20 °C +68 °F	+ 20 °C +68 °F	12710 28572	16219 36461	2716 165.73	31,55 69.56	✓
LS 7500 - 200 - B	LS 7500 - 200 - C	200 7.87	555 21.85	355 13.98			12922 29050	16599 37316	3332 203.31	35,15 77.49	✓
LS 7500 - 250 - B	LS 7500 - 250 - C	250 9.84	655 25.79	405 15.94			13103 29457	16925 38049	4101 250.28	38,65 85.21	✓
LS 7500 - 300 - B	LS 7500 - 300 - C	300 11.81	755 29.72	455 17.91			13229 29741	17154 38564	4871 297.26	42,55 93.81	✓

◆ Disposable

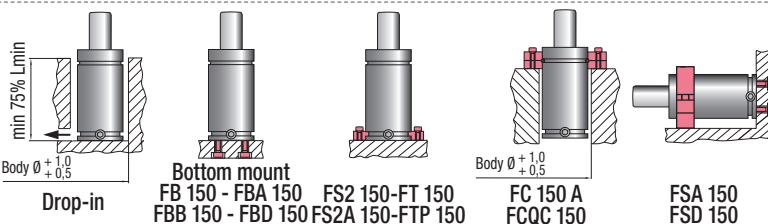

HOW TO ORDER

Hand icon p. 157

INSTALLATION GUIDELINE

Hand icon p. 205

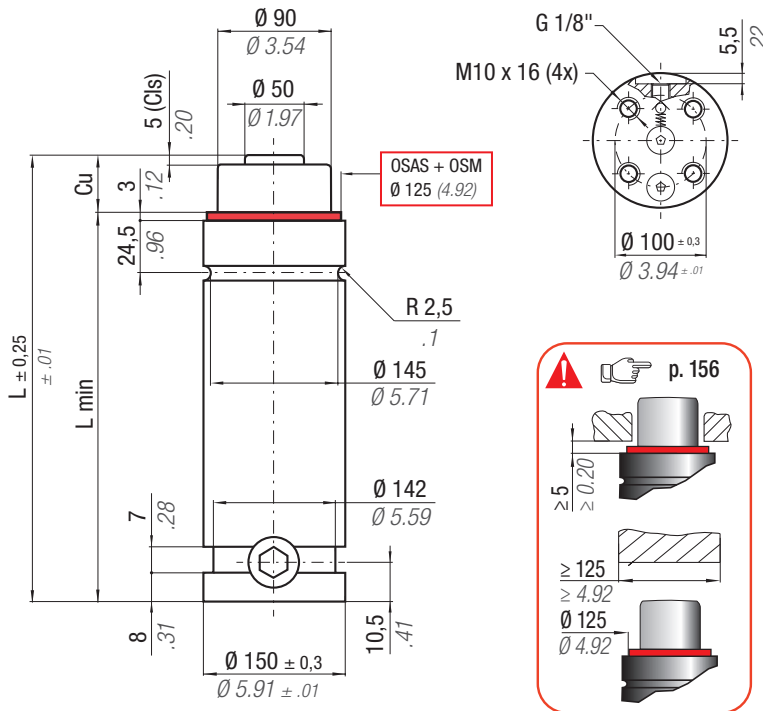

Il nuovo codice sarà fornito solo ad esaurimento del vecchio

The new code will be supplied only when the old will be out of stock

Der neue Kode wird nur angegeben, wenn der alte nicht mehr lieferbar ist

Le nouveau code sera fourni uniquement lorsque le vieux stock sera écoulé

El nuevo código será suministrado sólo cuando se agoten las existencias del antiguo

O novo código irá ser fornecido apenas quando o antigo esgotar stock

ACTIVE SAFETY



OSAS



USAS



OPAS



* F_{1i} =

Isothermal end force at 100% Cu



** F_{1p} =

Polytrophic end force at 100% Cu



		0 - 80 °C 32 - 176 °F	ΔP ± 0,33 %/°C	P max 150 bar 2175 psi	P min 20 bar 290 psi	S 63,61 cm ² 9.860 in ²	SPM ~ 15 - 60 (at 20°C)	Max Speed 1,8 m/s 70.8 in/s	Maintenance kit 39BMLS07500A	
CODE	NEW	Cu	L	L min	F ₀	F CIs	F _{1i} *	F _{1p} **	V ₀	
PHASING OUT from 04/2021		mm inch	mm inch	mm inch	Initial force daN lb	daN lb	End force * daN lb	End force ** daN lb	cm ³ in ³	~Kg ~lb 2014/68/EU
LS 9500 - 025 - B	LS 9500-025 - C	25 0.98	205 8.07	180 7.09			12436 27958	14197 31916	638 38.91	19,95 43.98 ✓
LS 9500 - 038 - B	LS 9500-038 - C	38 1.50	231 9.09	193 7.60			13451 30239	15755 35419	838 51.13	21,15 46.63 ✓
LS 9500 - 050 - B	LS 9500-050 - C	50 1.97	255 10.04	205 8.07	0 0	9540 21446	14107 31713	16783 37729	1023 62.40	21,95 48.39 ✓
LS 9500 - 063 - B	LS 9500-063 - C	63,5 2.50	282 11.10	218,5 8.60	± 5%	± 5%	14650 32935	17647 39671	1230 75.08	22,75 50.16 ✓
LS 9500 - 080 - B	LS 9500-080 - C	80 3.15	315 12.40	235 9.25			15138 34032	18432 41436	1484 90.58	24,55 54.12 ✓
LS 9500 - 100 - B	LS 9500-100 - C	100 3.94	355 13.98	255 10.04	150 bar 2175 psi	150 bar 2175 psi	15568 34998	19129 43005	1792 109.37	26,25 57.87 ✓
LS 9500 - 125 - B	LS 9500-125 - C	125 4.92	405 15.94	280 11.02			15952 35862	19759 44420	2177 132.85	28,15 62.06 ✓
LS 9500 - 160 - B	LS 9500-160 - C	160 6.30	475 18.70	315 12.40	+ 20 °C +68 °F	+ 20 °C +68 °F	16323 36695	20371 45796	2716 165.73	31,55 69.56 ✓
LS 9500 - 200 - B	LS 9500-200 - C	200 7.87	555 21.85	355 13.98			16610 37341	20848 46869	3332 203.31	35,15 77.49 ✓
LS 9500 - 250 - B	LS 9500-250 - C	250 9.84	655 25.79	405 15.94			16855 37892	21258 47789	4101 250.28	38,65 85.21 ✓
LS 9500 - 300 - B	LS 9500-300 - C	300 11.81	755 29.72	455 17.91			17027 38278	21545 48436	4871 297.26	42,55 93.81 ✓

◆ Disposable

LS

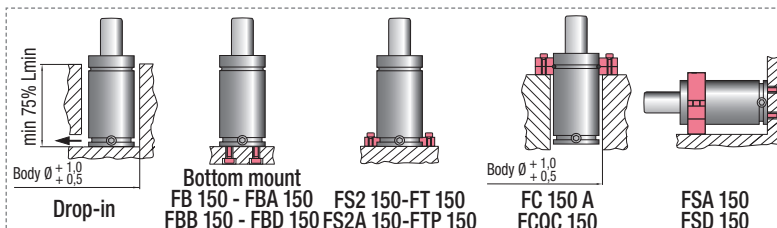

HOW TO ORDER

p. 157

INSTALLATION GUIDELINE

p. 205

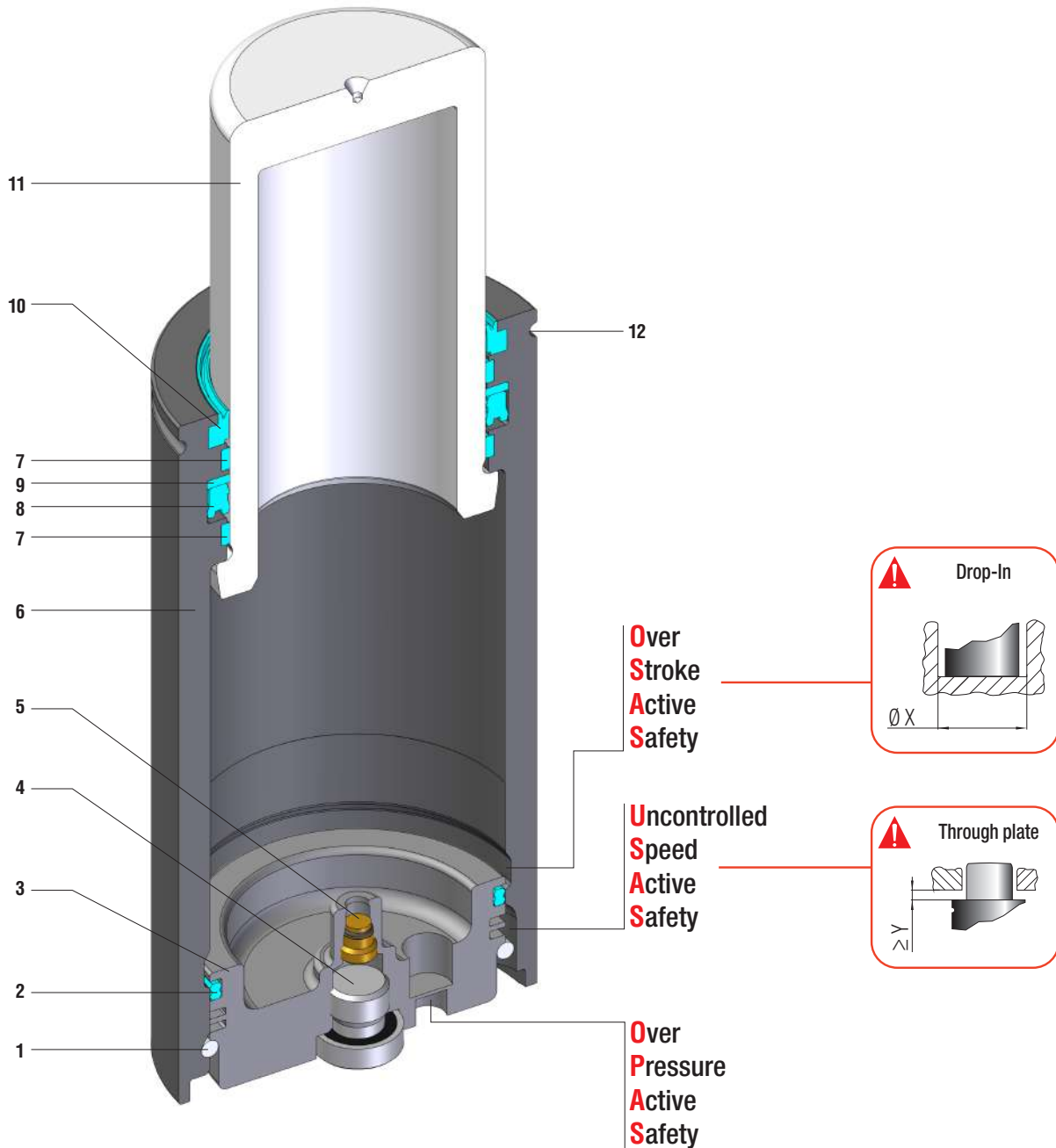

Massima forza, tenuta stelo - Maximum force, rod seal - Maximale Kraft, Kolbenstange dichtung
 Forces maximale, joint de tige - Máxima fuerza, estanqueidad vástago - Força máxima, estanquidade na haste

SEALING	ROD SEAL
DESIGN	BOTTOM BASE - BODY DESIGN

1	Retaining ring	5	Valve	9	Back-up ring
2	Dual ring seal	6	Body	10	Rod wiper
3	Bottom base	7	Guide ring	11	Rod (nitrited superfinished)
4	Plug	8	Rod seal	12	Groove for secondary wiper

RANGE CHART

Model	Body Ø		Stroke Cu		Initial force F0						
	mm	inch	mm	inch	daN	lb	OSAS	USAS	OPAS	SKUDO	SW
ML 300	25	0.98	10 - 80	0.39 - 3.15	310	697	✓	✓	-	-	✓
ML 500	32	1.26	10 - 80	0.39 - 3.15	510	1147	✓	✓	-	-	✓
ML 1000	38	1.50	10 - 80	0.39 - 3.15	980	2203	✓	✓	✓	-	✓
ML 1000 N	38	1.50	10 - 80	0.39 - 3.15	980	2203	✓	✓	✓	-	✓
ML 1800	50	1.97	15 - 80	0.59 - 3.15	1925	4327	✓	✓	✓	-	✓
ML 1800 N	50	1.97	15 - 80	0.59 - 3.15	1925	4327	✓	✓	✓	-	✓
ML 3000	63	2.48	15 - 80	0.59 - 3.15	3180	7149	✓	✓	✓	-	✓
ML 3000 N	63	2.48	15 - 80	0.59 - 3.15	3180	7149	✓	✓	✓	-	✓
ML 4700	75	2.95	15 - 80	0.59 - 3.15	4925	11701	✓	✓	✓	-	✓
ML 4700 N	75	2.95	15 - 80	0.59 - 3.15	4925	11701	✓	✓	✓	-	✓
ML 7500	95	3.74	15 - 80	0.59 - 3.15	7700	17310	✓	✓	✓	-	✓
ML 7500 N	95	3.74	15 - 80	0.59 - 3.15	7700	17310	✓	✓	✓	-	✓
ML 12000	120	4.72	15 - 80	0.59 - 3.15	12720	28595	✓	✓	✓	-	✓
ML 12000 N	120	4.72	15 - 80	0.59 - 3.15	12720	28595	✓	✓	✓	-	✓

✓ Built-in as standard

✓ Optional upon request

HOW TO ORDER

Series _____ Revision code _____

Model **ML 1800-050-D-E-W**

Stroke _____ Version _____

Available versions

ML 1800-050-D Standard code	ML 1800-050-D-W Add "-W" to standard code	ML 1800-050-D-N Add "-N" to standard code	ML 1800-050-D-N-W Add "-N-W" to standard code	ML 1800-050-D-E Add "-E" to standard code	ML 1800-050-D-E-W Add "-E-W" to standard code
Self contained	Self contained + Secondary wiper	Linkable	Linkable + Secondary wiper	Easy Manifold	Easy Manifold + Secondary wiper

ML



SW

ACTIVE SAFETY



OSAS



USAS

Il nuovo codice sarà fornito solo ad esaurimento del vecchio

The new code will be supplied only when the old will be out of stock

Der neue Kode wird nur angegeben, wenn der alte nicht mehr lieferbar ist

Le nouveau code sera fourni uniquement lorsque le vieux stock sera écoulé

El nuevo código será suministrado sólo cuando se agoten las existencias del antiguo

O novo código irá ser fornecido apenas quando o antigo esgotar stock

* $F_{1i} =$

Isothermal end force p. 16

** $F_{1p} =$

Polytropic end force at 100% Cu

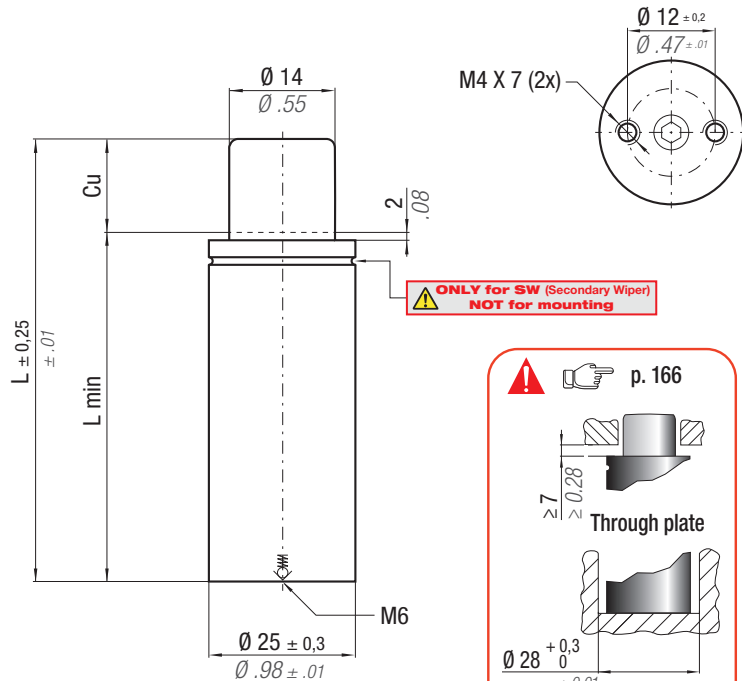

N ₂	0 - 80 °C 32 - 176 °F	ΔP ± 0,33 %/°C	P max 200 bar 2900 psi	P min 20 bar 290 psi	S 1,54 cm ² 0.239 in ²	SPM ~ 40 - 80 (at 20°C)	Max Speed 1,6 m/s 62.9 in/s	Maintenance kit Disposable	
CODE	NEW	Cu	L	L min	F ₀	F _{1i} *	F _{1p} **	V ₀	PED 2014/68/EU
PHASING OUT from 05/2019		mm inch	mm inch	mm inch	Initial force daN lb	End force * daN lb	End force ** daN lb	cm ³ in ³	~Kg ~lb
ML 300 - 010 - C	ML 300 - 010 - D	10 0.39	75 2.95	65 2.56	310 697 ± 5%	430 967	484 1087	6,8 0.41	0,17 0.37
ML 300 - 015 - C	ML 300 - 015 - D	15 0.59	85 3.35	70 2.76		467 1050	534 1201	8,5 0.52	0,18 0.40
ML 300 - 025 - C	ML 300 - 025 - D	25 0.98	105 4.13	80 3.15	200 bar 2900 psi	518 1164	605 1360	11,8 0.72	0,21 0.46
ML 300 - 038 - C	ML 300 - 038 - D	38 1.50	130 5.12	92 3.62		566 1272	674 1514	15,7 0.96	0,24 0.53
ML 300 - 050 - C	ML 300 - 050 - D	50 1.97	155 6.10	105 4.13	+20 °C +68 °F	583 1311	698 1570	20,0 1.22	0,27 0.60
ML 300 - 063 - C	ML 300 - 063 - D	63 2.48	185 7.28	122 4.80		580 1303	693 1558	25,3 1.54	0,31 0.68
ML 300 - 080 - C	ML 300 - 080 - D	80 3.15	220 8.66	140 5.51		595 1337	715 1608	31,2 1.90	0,35 0.77

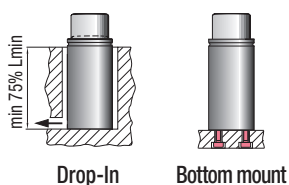

HOW TO ORDER

p. 167

INSTALLATION GUIDELINE

p. 205

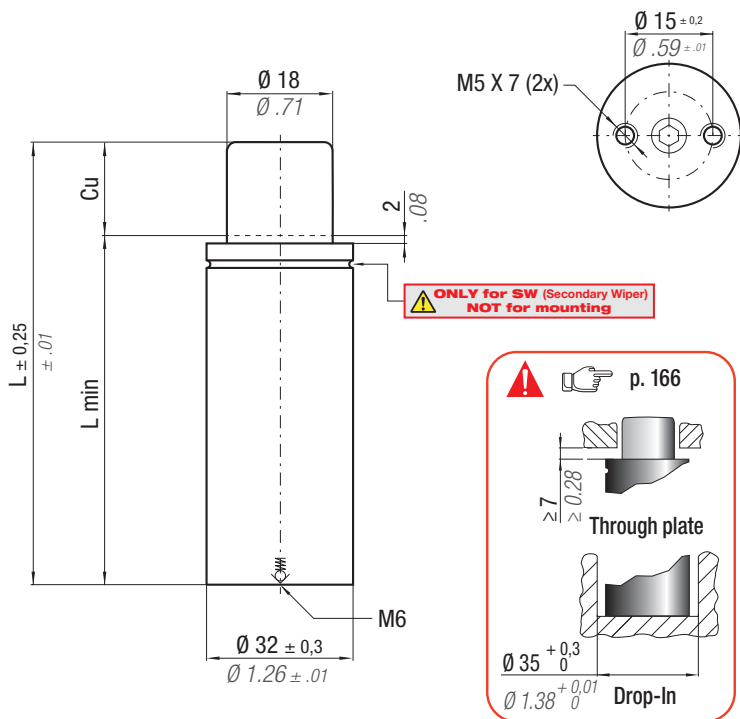

Il nuovo codice sarà fornito solo ad esaurimento del vecchio

The new code will be supplied only when the old will be out of stock

Der neue Kode wird nur angegeben, wenn der alte nicht mehr lieferbar ist

Le nouveau code sera fourni uniquement lorsque le vieux stock sera écoulé

El nuevo código será suministrado sólo cuando se agoten las existencias del antiguo

O novo código irá ser fornecido apenas quando o antigo esgotar stock

* $F_{1i} =$

Isothermal end force at 100% Cu

p. 16

** $F_{1p} =$

Polytrophic end force at 100% Cu



SW

ACTIVE SAFETY



OSAS



USAS

N ₂		0 - 80 °C 32 - 176 °F	ΔP ± 0,33 %/°C	P max 200 bar 2900 psi	P min 20 bar 290 psi	S 2,54 cm ² 0.394 in ²	SPM ~ 40 - 80 (at 20°C)	Max Speed 1,6 m/s 62.9 in/s	Maintenance kit Disposabile
CODE	NEW	Cu	L	L min	F ₀	F _{1i} *	F _{1p} **	V ₀	PED
PHASING OUT from 05/2019		mm inch	mm inch	mm inch	Initial force daN lb	End force * daN lb	End force ** daN lb	cm ³ in ³	~Kg ~lb 2014/68/EU
ML 500 - 010 - C	ML 500 - 010 - D	10 0.39	75 2.95	65 2.56	510 1147	718 1614	809 1819	11,0 0.67	0,28 0.62 ✓
ML 500 - 015 - C	ML 500 - 015 - D	15 0.59	85 3.35	70 2.76	± 5%	775 1742	887 1994	13,9 0.85	0,30 0.66 ✓
ML 500 - 025 - C	ML 500 - 025 - D	25 0.98	105 4.13	80 3.15		849 1908	990 2226	19,7 1.20	0,34 0.75 ✓
ML 500 - 038 - C	ML 500 - 038 - D	38 1.50	130 5.12	92 3.62	200 bar 2900 psi	917 2061	1087 2443	26,7 1.63	0,39 0.86 ✓
ML 500 - 050 - C	ML 500 - 050 - D	50 1.97	155 6.10	105 4.13		937 2107	1116 2510	34,1 2.08	0,43 0.95 ✓
ML 500 - 063 - C	ML 500 - 063 - D	63 2.48	190 7.48	127 5.00		892 2006	1052 2364	46,0 2.81	0,51 1.12 ✓
ML 500 - 080 - C	ML 500 - 080 - D	80 3.15	225 8.86	145 5.71	+20 °C +68 °F	916 2059	1086 2441	56,3 3.44	0,57 1.26 ✓

ML

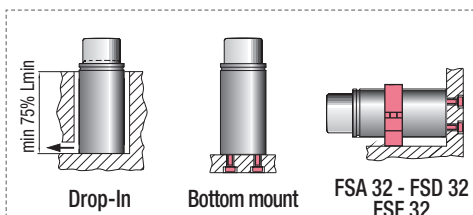

HOW TO ORDER

p. 167

INSTALLATION GUIDELINE

p. 205



SW

Il nuovo codice sarà fornito solo ad esaurimento del vecchio
 The new code will be supplied only when the old will be out of stock

ACTIVE SAFETY



OSAS

Der neue Kode wird nur angegeben, wenn der alte nicht mehr lieferbar ist



USAS

Le nouveau code sera fourni uniquement lorsque le vieux stock sera écoulé



OPAS

El nuevo código será suministrado sólo cuando se agoten las existencias del antiguo

O novo código irá ser fornecido apenas quando o antigo esgotar stock



* F_{1i} = Isothermal end force at 100% Cu p. 16
 ** F_{1p} = Polytrophic end force at 100% Cu

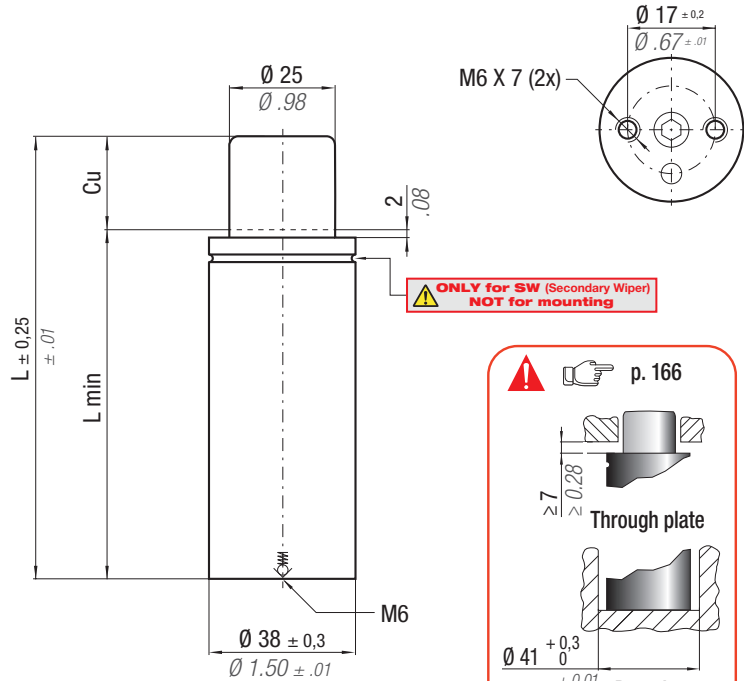

N ₂	0 - 80 °C 32 - 176 °F	ΔP ± 0,33 %/°C	P max 200 bar 2900 psi	P min 20 bar 290 psi	S 4,91 cm ² 0,761 in ²	SPM ~ 40 - 80 (at 20°C)	Max Speed 1,6 m/s 62.9 in/s	Maintenance kit 39BMMLO1000C
----------------	--------------------------	---------------------------	------------------------------	----------------------------	----------------------------------------------------	-------------------------------	-----------------------------------	---------------------------------

CODE PHASING OUT from 05/2019	NEW	Cu		L		L min		F ₀ Initial force		F _{1i} * End force *		F _{1p} ** End force **		V ₀		~Kg ~lb	PED 2014/68/EU	
		mm	inch	mm	inch	mm	inch	daN	lb	daN	lb	daN	lb	cm ³	in ³			
ML 1000 - 010 - C	ML 1000 - 010 - D	10	0.39	75	2.95	65	2.56	980	2203	1377	3096	1550	3485	21,6	1.32	0,37	0,82	✓
ML 1000 - 015 - C	ML 1000 - 015 - D	15	0.59	85	3.35	70	2.76											
ML 1000 - 025 - C	ML 1000 - 025 - D	25	0.98	105	4.13	80	3.15	200 bar	2900 psi	1700	3822	1999	4494	35,8	2.18	0,45	0,99	✓
ML 1000 - 038 - C	ML 1000 - 038 - D	38	1.50	135	5.31	97	3.82											
ML 1000 - 050 - C	ML 1000 - 050 - D	50	1.97	160	6.30	110	4.33	+20 °C	+68 °F	1871	4206	2244	5045	63,1	3.85	0,60	1,32	✓
ML 1000 - 063 - C	ML 1000 - 063 - D	63	2.48	205	8.07	142	5.59											
ML 1000 - 080 - C	ML 1000 - 080 - D	80	3.15	240	9.45	160	6.30	1805	4058	2149	4830	105,6	6.44	0,82	1,81	✓		

KIT FOR LINKING

code: 39FML01000D

Seal (1x)

Washer (4x)

Screw (2x)

Bottom base (1x)

Valve (1x)

Instructions

! Sostituire ogni 1.000.000 di cicli. Replace every 1 million cycles. Nach 1 Mio. Hübe austauschen. Reemplazar a cada 1 millón de ciclos. Substituir a cada 1 milhão de ciclos.

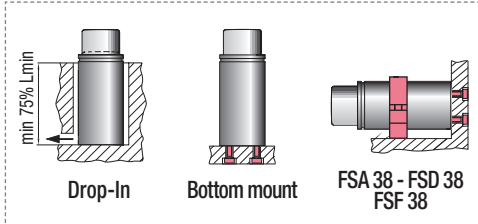
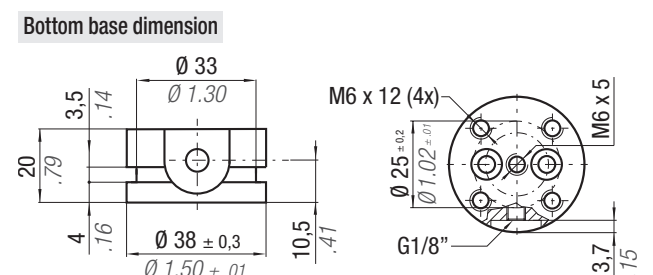

HOW TO ORDER

p. 167

INSTALLATION GUIDELINE

p. 205

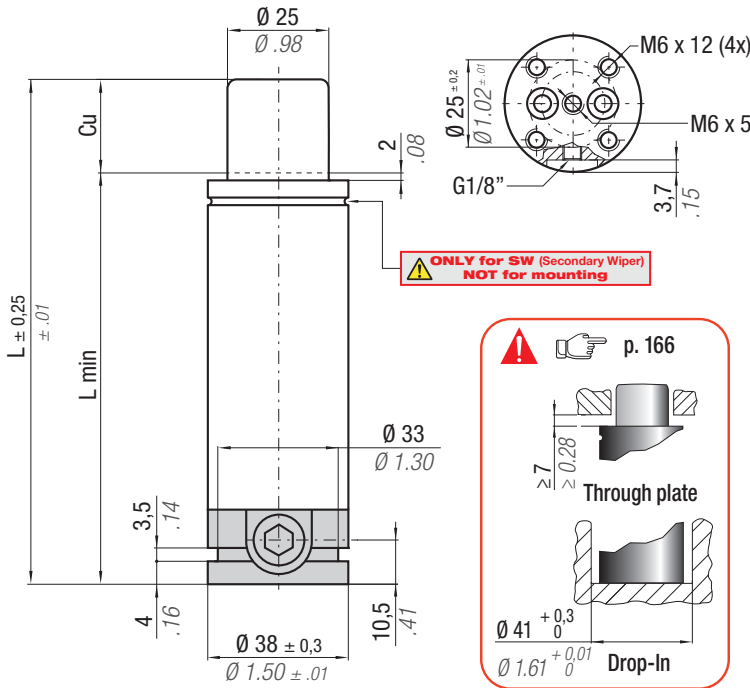

**ONLY for SW (Secondary Wiper)
NOT for mounting**

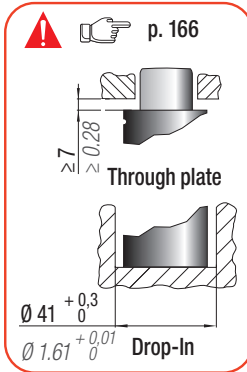

Il nuovo codice sarà fornito solo ad esaurimento del vecchio

The new code will be supplied only when the old will be out of stock

Der neue Kode wird nur angegeben, wenn der alte nicht mehr lieferbar ist

Le nouveau code sera fourni uniquement lorsque le vieux stock sera écoulé

El nuevo código será suministrado sólo cuando se agoten las existencias del antiguo

O novo código irá ser fornecido apenas quando o antigo esgotar stock



* F_{1i} =

Isothermal end force at 100% Cu



** F_{1p} =

Polytrophic end force at 100% Cu



SW

ACTIVE SAFETY



OSAS



USAS



OPAS

N ₂		0 - 80 °C 32 - 176 °F	ΔP ± 0,33 %/°C	P max 200 bar 2900 psi	P min 20 bar 290 psi	S 4,91 cm ² 0.761 in ²	SPM ~ 40 - 80 (at 20°C)	Max Speed 1,6 m/s 62.9 in/s	Maintenance kit 39BMMLO1000C
CODE	NEW	Cu	L	L min	F ₀	F _{1i} *	F _{1p} **	V ₀	
PHASING OUT from 05/2019		mm inch	mm inch	mm inch	Initial force daN lb	End force * daN lb	End force ** daN lb	cm ³ in ³	~Kg ~lb
ML1000-010-C-N	ML1000-010-D-N	10 0.39	95 3.74	85 3.35	980 2203	1377 3096	1550 3485	21,6 1.32	0,52 1.15
ML1000-015-C-N	ML1000-015-D-N	15 0.59	105 4.13	90 3.54	± 5%	1509 3392	1731 3892	26,3 1.60	0,55 1.21
ML1000-025-C-N	ML1000-025-D-N	25 0.98	125 4.92	100 3.94		1700 3822	1999 4494	35,8 2.18	0,60 1.32
ML1000-038-C-N	ML1000-038-D-N	38 1.50	155 6.10	117 4.61	200 bar	1782 4007	2116 4757	51,0 3.11	0,68 1.50
ML1000-050-C-N	ML1000-050-D-N	50 1.97	180 7.09	130 5.12	2900 psi	1871 4206	2244 5045	63,1 3.85	0,75 1.65
ML1000-063-C-N	ML1000-063-D-N	63 2.48	225 8.86	162 6.38		1721 3868	2028 4560	88,8 5.42	0,88 1.94
ML1000-080-C-N	ML1000-080-D-N	80 3.15	260 10.24	180 7.09	+20 °C +68 °F	1805 4058	2149 4830	105,6 6.44	0,98 2.16

SERVICE BOX

code: 39SKML01000A



Seal (1x)



Washer (4x)



Screw (2x)



Instructions



Sostituire ogni 1.000.000 di cicli. Rempilacez à chaque million de cycles.
Replace every 1 million cycles. Reemplazar cada 1 millón de ciclos.
Nach 1 Mio. Hübe austauschen. Substituir a cada 1 milhão de ciclos.

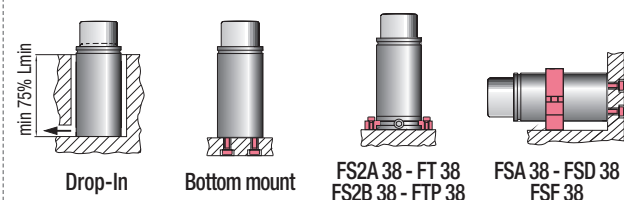

HOW TO ORDER

Hand icon p. 167

INSTALLATION GUIDELINE

Hand icon p. 205



SW

Il nuovo codice sarà fornito solo ad esaurimento del vecchio
 The new code will be supplied only when the old will be out of stock

ACTIVE SAFETY



OSAS

Der neue Kode wird nur angegeben, wenn der alte nicht mehr lieferbar ist



USAS

Le nouveau code sera fourni uniquement lorsque le vieux stock sera écoulé



OPAS

El nuevo código será suministrado sólo cuando se agoten las existencias del antiguo

O novo código irá ser fornecido apenas quando o antigo esgotar stock



* F_{1i} = Isothermal end force at 100% Cu
 p. 16

** F_{1p} = Polytrophic end force at 100% Cu
 p. 16

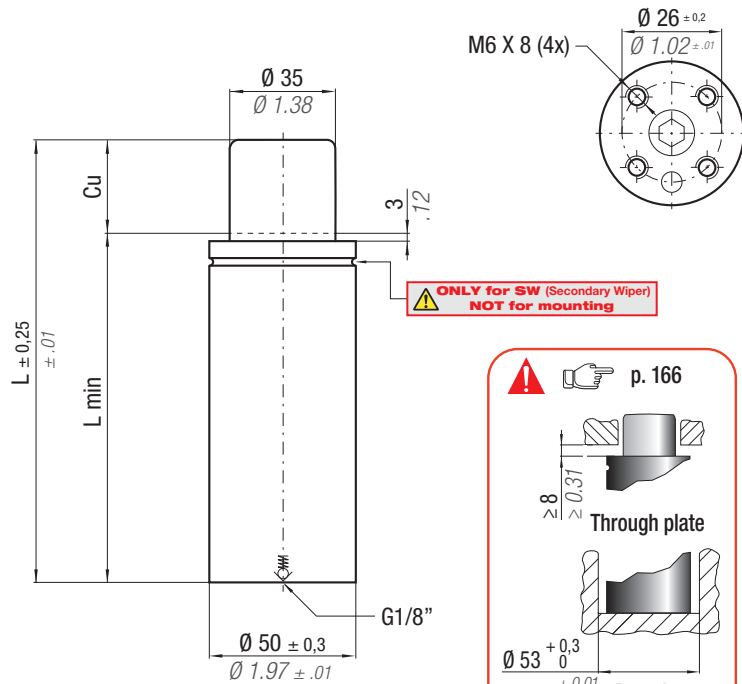

N ₂	0 - 80 °C 32 - 176 °F	ΔP ± 0,33 %/°C	P max 200 bar 2900 psi	P min 20 bar 290 psi	S 9,62 cm ² 1.491 in ²	SPM ~ 40 - 80 (at 20°C)	Max Speed 1,6 m/s 62.9 in/s	Maintenance kit 39BMMLO1800C
----------------	--------------------------	---------------------------	------------------------------	----------------------------	----------------------------------------------------	-------------------------------	-----------------------------------	---------------------------------

CODE PHASING OUT from 05/2019	NEW	Cu		L		L min		F ₀ Initial force		F _{1i} * End force *		F _{1p} ** End force **		V ₀		PED 2014/68/EU	
		mm	inch	mm	inch	mm	inch	daN	lb	daN	lb	daN	lb	cm ³	in ³		~Kg
-	ML 1800 - 010 - D	10	0.39	85	3.35	95	3.74	1925 4327 ± 5%	2597 5839	2901 6522	47	2.87	0,72	1.59	✓		
ML 1800 - 015 - C	ML 1800 - 015 - D	15	0.59	95	3.74	80	3.15									2828	6358
ML 1800 - 025 - C	ML 1800 - 025 - D	25	0.98	115	4.53	90	3.54	200 bar 2900 psi	3198	7189	3728	8381	75	4.56	0,85	1.87	✓
ML 1800 - 038 - C	ML 1800 - 038 - D	38	1.50	150	5.91	112	4.41										
ML 1800 - 050 - C	ML 1800 - 050 - D	50	1.97	175	6.89	125	4.92	+20 °C +68 °F	3471	7802	4115	9252	133	8.10	1,12	2.47	✓
ML 1800 - 063 - C	ML 1800 - 063 - D	63	2.48	205	8.07	142	5.59										
ML 1800 - 080 - C	ML 1800 - 080 - D	80	3.15	245	9.65	165	6.50		3642	8188	4362	9805	200	12.18	1,44	3.17	✓

KIT FOR LINKING

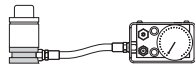

code: 39FML01800C



Seal (1x)



Washer (4x)



Screw (2x)



Bottom base (1x)



Valve (1x)



Instructions



Sostituire ogni 1.000.000 di cicli. Replace every 1 million cycles. Nach 1 Mio. Hübe austauschen. Reemplazar cada 1 millón de ciclos. Substituir a cada 1 milhão de ciclos.

Bottom base dimension

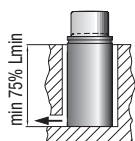
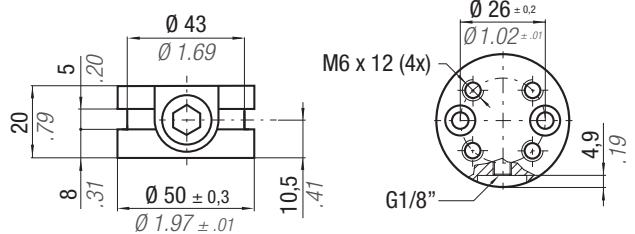

Drop-In

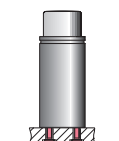

Bottom mount

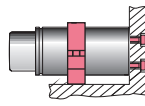

FSA 50 - FSD 50
FSE 50

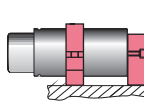

FSD 50 + R 50 A
FSE 50 + R 50 A

HOW TO ORDER

p. 167

INSTALLATION GUIDELINE

p. 205

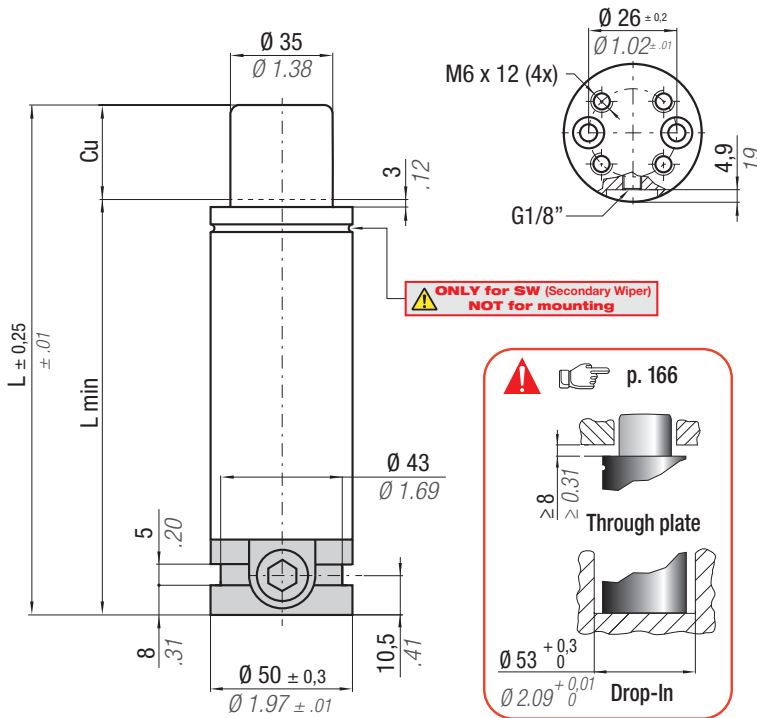

Il nuovo codice sarà fornito solo ad esaurimento del vecchio

The new code will be supplied only when the old will be out of stock

Der neue Kode wird nur angegeben, wenn der alte nicht mehr lieferbar ist

Le nouveau code sera fourni uniquement lorsque le vieux stock sera écoulé

El nuevo código será suministrado sólo cuando se agoten las existencias del antiguo

O novo código irá ser fornecido apenas quando o antigo esgotar stock



* $F_{1i} =$

Isothermal end force at 100% Cu

Hand icon p. 16

** $F_{1p} =$

Polytrophic end force at 100% Cu

Hand icon



SW

ACTIVE SAFETY



OSAS



USAS



OPAS

CODE	PHASING OUT from 05/2019	NEW	ΔP		P_{max}	P_{min}	S	SPM	Max Speed	Maintenance kit		
			mm	inch	200 bar 2900 psi	20 bar 290 psi	9,62 cm ² 1.491 in ²	~ 40 - 80 (at 20°C)	1,6 m/s 62.9 in/s	39BMMLO1800C		
			Cu	L	L_{min}	F_0	F_{1i}	F_{1p}	V_0	PED 2014/68/EU		
			mm	inch	mm	inch	daN	lb	cm ³	in ³	~Kg	~lb

SERVICE BOX

code: 39SKML01800A



Sostituire ogni 1.000.000 di cicli. Replace every 1 million cycles. Nach 1 Mio. Hübe austauschen. Reemplazar cada 1 millón de ciclos. Substituir a cada 1 milhão de ciclos.

HOW TO ORDER

Hand icon p. 167

INSTALLATION GUIDELINE

Hand icon p. 205

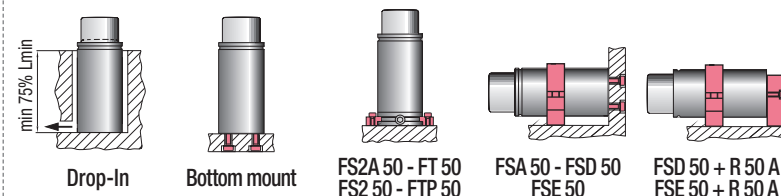



SW

ACTIVE SAFETY



OSAS



USAS



OPAS

Il nuovo codice sarà fornito solo ad esaurimento del vecchio

The new code will be supplied only when the old will be out of stock

Der neue Kode wird nur angegeben, wenn der alte nicht mehr lieferbar ist

Le nouveau code sera fourni uniquement lorsque le vieux stock sera écoulé

El nuevo código será suministrado sólo cuando se agoten las existencias del antiguo

O novo código irá ser fornecido apenas quando o antigo esgotar stock



p. 247

* F_{1i} =

Isothermal end force at 100% Cu p. 16

** F_{1p} =

Polytrophic end force at 100% Cu p. 16

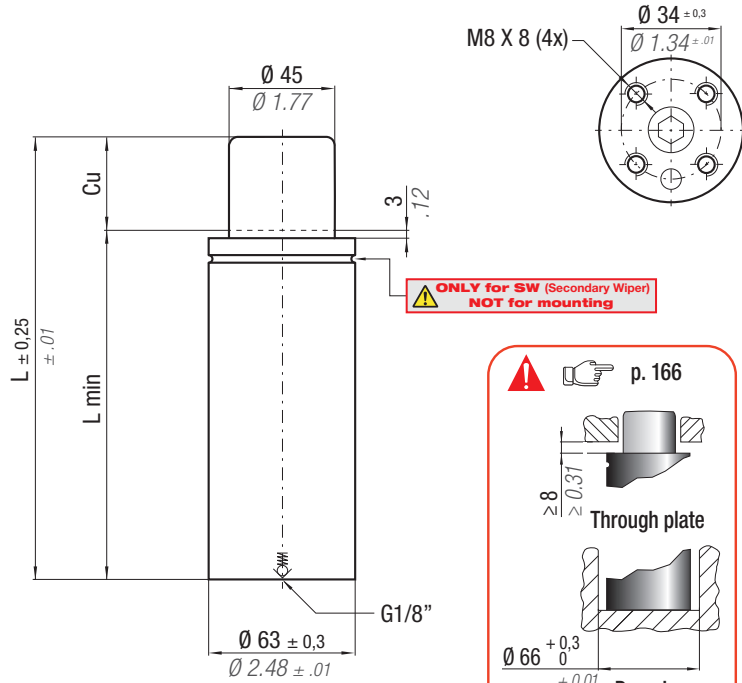

N ₂	0 - 80 °C 32 - 176 °F	ΔP ± 0,33 %/°C	P max 200 bar 2900 psi	P min 20 bar 290 psi	S 15,90 cm ² 2.464 in ²	SPM ~ 40 - 80 (at 20°C)	Max Speed 1,6 m/s 62.9 in/s	Maintenance kit 39BMMLO3000C	
CODE	NEW	Cu	L	L min	F₀	F_{1i} *	F_{1p} **	V₀	
PHASING OUT from 05/2019		mm inch	mm inch	mm inch	Initial force	End force *	End force **	cm ³ in ³	~Kg ~lb
ML 3000 - 015 - C	ML 3000 - 015 - D	15 0.59	100 3.94	85 3.35	3180 7149	4461 10029	5023 11291	105 6.40	1,25 2.76
ML 3000 - 025 - C	ML 3000 - 025 - D	25 0.98	120 4.72	95 3.74	± 5%	5013 11270	5781 12997	136 8.27	1,38 3.04
ML 3000 - 038 - C	ML 3000 - 038 - D	38 1.50	150 5.91	112 4.41	200 bar	5362 12054	6269 14094	184 11.22	1,57 3.46
ML 3000 - 050 - C	ML 3000 - 050 - D	50 1.97	180 7.09	130 5.12	2900 psi	5491 12344	6452 14505	233 14.24	1,78 3.92
ML 3000 - 063 - C	ML 3000 - 063 - D	63 2.48	210 8.27	147 5.79		5658 12720	6690 15039	282 17.19	1,98 4.37
ML 3000 - 080 - C	ML 3000 - 080 - D	80 3.15	250 9.84	170 6.69	+20 °C +68 °F	5793 13023	6882 15472	347 21.14	2,24 4.94

KIT FOR LINKING

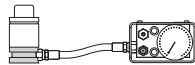

code: 39FML03000B



Seal (1x)



Washer (6x)



Screw (3x)



Bottom base (1x)



Valve (1x)



Instructions



Sostituire ogni 1.000.000 di cicli. Replace every 1 million cycles. Nach 1 Mio. Hübe austauschen. Remplacez à chaque million de cycles. Reemplazar cada 1 millón de ciclos. Substituir a cada 1 milhão de ciclos.

Bottom base dimension

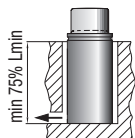
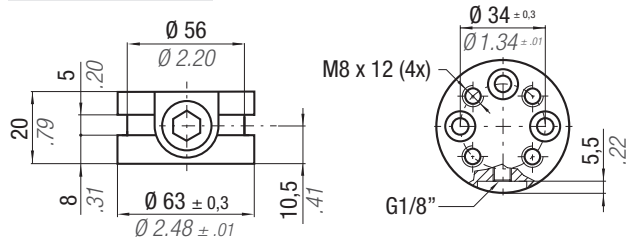

Drop-In



Bottom mount

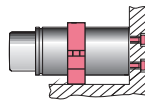

FSC 63 - FSD 63

HOW TO ORDER

p. 167

INSTALLATION GUIDELINE

p. 205

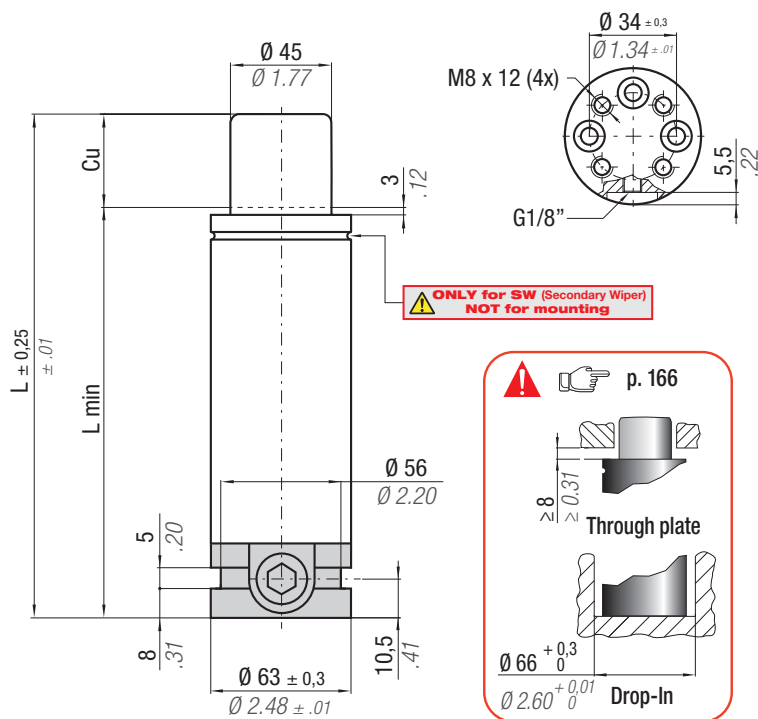

**ONLY for SW (Secondary Wiper)
NOT for mounting**

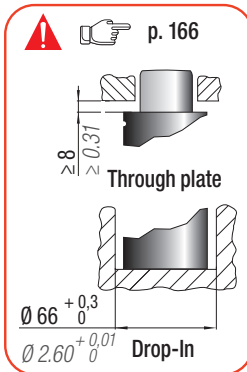

Il nuovo codice sarà fornito solo ad esaurimento del vecchio
 The new code will be supplied only when the old will be out of stock
 Der neue Kode wird nur angegeben, wenn der alte nicht mehr lieferbar ist
 Le nouveau code sera fourni uniquement lorsque le vieux stock sera écoulé
 El nuevo código será suministrado sólo cuando se agoten las existencias del antiguo
 O novo código irá ser fornecido apenas quando o antigo esgotar stock



* F_{1i} = Isothermal end force at 100% Cu
 ** F_{1p} = Polytrophic end force at 100% Cu
 p. 16



ACTIVE SAFETY



N ₂		0 - 80 °C 32 - 176 °F	ΔP ± 0,33 %/°C	P max 200 bar 2900 psi	P min 20 bar 290 psi	S 15,90 cm ² 2.464 in ²	SPM ~ 40 - 80 (at 20°C)	Max Speed 1,6 m/s 62.9 in/s	Maintenance kit 39BMMML03000C
CODE	NEW	Cu	L	L min	F ₀	F _{1i} *	F _{1p} **	V ₀	
PHASING OUT from 05/2019		mm inch	mm inch	mm inch	Initial force daN lb	End force * daN lb	End force ** daN lb	cm ³ in ³	~Kg ~lb
ML3000-015-C-N	ML3000-015-D-N	15 0.59	120 4.72	105 4.13	3180 7149	4461 10029	5023 11291	105 6.40	1,67 3,68
ML3000-025-C-N	ML3000-025-D-N	25 0.98	140 5.51	115 4.53	± 5%	5013 11270	5781 12997	136 8.27	1,80 3,97
ML3000-038-C-N	ML3000-038-D-N	38 1.50	170 6.69	132 5.20	200 bar 2900 psi	5362 12054	6269 14094	184 11.22	2,00 4,41
ML3000-050-C-N	ML3000-050-D-N	50 1.97	200 7.87	150 5.91		5491 12344	6452 14505	233 14.24	2,20 4,85
ML3000-063-C-N	ML3000-063-D-N	63 2.48	230 9.06	167 6.57		5658 12720	6690 15039	282 17.19	2,40 5.29
ML3000-080-C-N	ML3000-080-D-N	80 3.15	270 10.63	190 7.48	+20 °C +68 °F	5793 13023	6882 15472	347 21.14	2,66 5.86

SERVICE BOX

code: 39SKML03000A



! Sostituire ogni 1.000.000 di cicli. Remplacez à chaque million de cycles.
 Replace every 1 million cycles. Reemplazar cada 1 millón de ciclos.
 Nach 1 Mio. Hübe austauschen. Substituir a cada 1 milhão de ciclos.

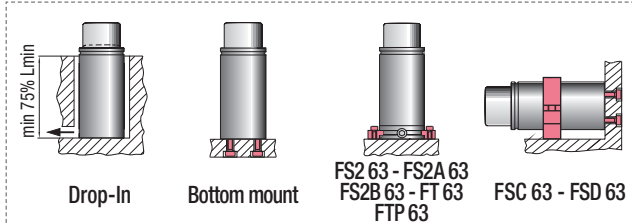

HOW TO ORDER

p. 167

INSTALLATION GUIDELINE

p. 205



SW

ACTIVE SAFETY



OSAS



USAS



OPAS

Il nuovo codice sarà fornito solo ad esaurimento del vecchio

The new code will be supplied only when the old will be out of stock

Der neue Kode wird nur angegeben, wenn der alte nicht mehr lieferbar ist

Le nouveau code sera fourni uniquement lorsque le vieux stock sera écoulé

El nuevo código será suministrado sólo cuando se agoten las existencias del antiguo

O novo código irá ser fornecido apenas quando o antigo esgotar stock

easu MANIFOLD p. 247

* F_{1i} = Isothermal end force at 100% Cu p. 16

** F_{1p} = Polytrophic end force at 100% Cu

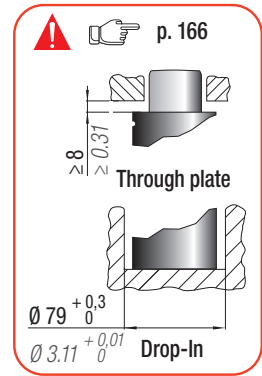
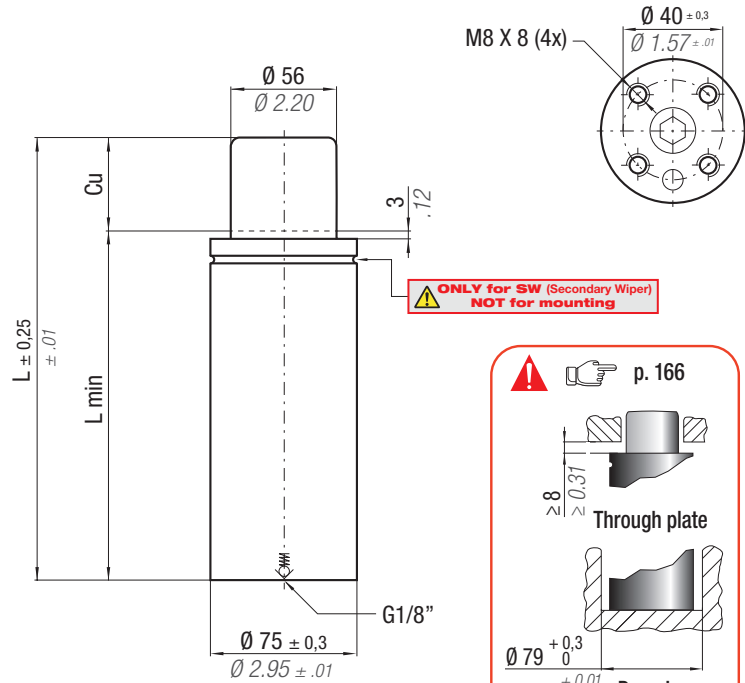

N ₂	0 - 80 °C 32 - 176 °F	ΔP ± 0,33 %/°C	P max 200 bar 2900 psi	P min 20 bar 290 psi	S 24,63 cm ² 3.817 in ²	SPM ~ 30 - 70 (at 20°C)	Max Speed 1,6 m/s 62.9 in/s	Maintenance kit 39BMMLO4700C		
CODE	NEW	Cu	L	L min	F ₀	F _{1i} *	F _{1p} **	V ₀		
PHASING OUT from 05/2019		mm inch	mm inch	mm inch	Initial force daN lb	End force * daN lb	End force ** daN lb	cm ³ in ³	~Kg ~lb	2014/68/EU
ML 4700 - 015 - C	ML 4700 - 015 - D	15 0.59	100 3.94	85 3.35	4925 11071	6982 15697	7878 17711	158 9.64	1,72 3.79	✓
ML 4700 - 025 - C	ML 4700 - 025 - D	25 0.98	120 4.72	95 3.74	± 5%	7883 17721	9119 20500	204 12.46	1,90 4.19	✓
ML 4700 - 038 - C	ML 4700 - 038 - D	38 1.50	150 5.91	112 4.41	200 bar 2900 psi	8462 19023	9933 22330	277 16.88	2,17 4.78	✓
ML 4700 - 050 - C	ML 4700 - 050 - D	50 1.97	180 7.09	130 5.12		8683 19520	10247 23035	351 21.39	2,44 5.38	✓
ML 4700 - 063 - C	ML 4700 - 063 - D	63 2.48	210 8.27	147 5.79		8963 20150	10647 23936	423 25.82	2,72 6.00	✓
ML 4700 - 080 - C	ML 4700 - 080 - D	80 3.15	250 9.84	170 6.69	+20 °C +68 °F	9191 20663	10975 24673	520 31.74	3,08 6.79	✓

KIT FOR LINKING

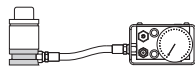

code: 39FML04700B



Seal (1x)



Washer (6x)



Screw (3x)



Bottom base (1x)



Valve (1x)



Instructions



Sostituire ogni 1.000.000 di cicli. Replace every 1 million cycles. Nach 1 Mio. Hübe austauschen. Remplacez à chaque million de cycles. Reemplazar cada 1 millón de ciclos. Substituir a cada 1 milhão de ciclos.

Bottom base dimension

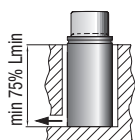
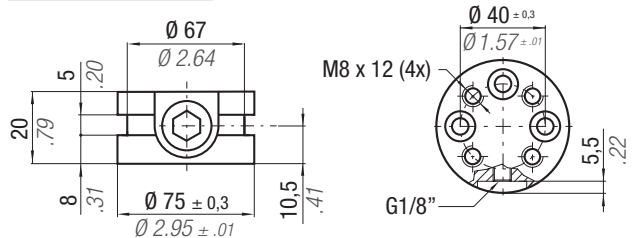

Drop-In

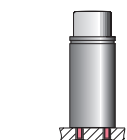

Bottom mount - FB 75
FBA 75 - FBB 75
FBC 75 - FBD 75

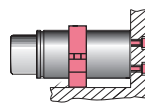

FSA 75 - FSD 75
FSE 75

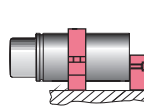

FSD 75 + R 75 A
FSE 75 + R 75 A

HOW TO ORDER

p. 167

INSTALLATION GUIDELINE

p. 205

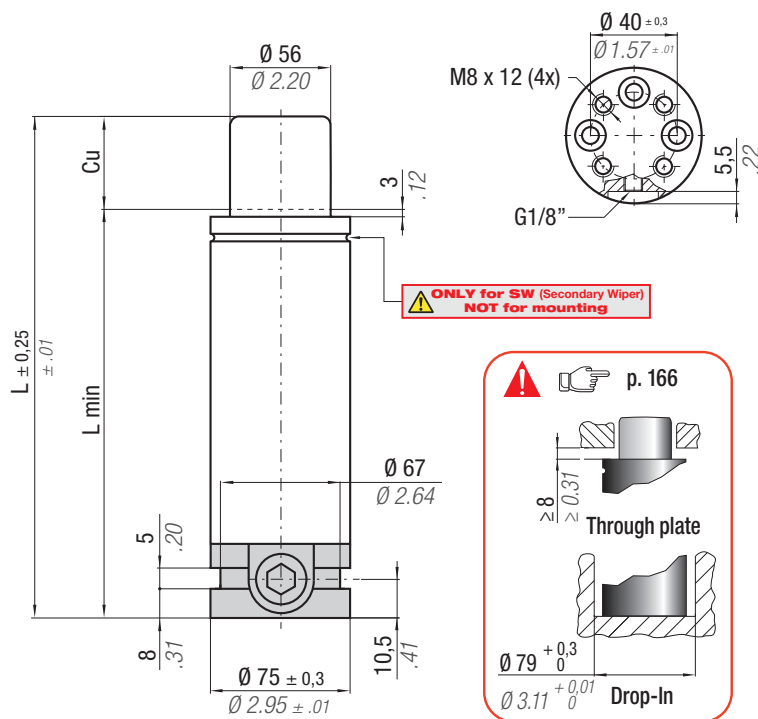

Il nuovo codice sarà fornito solo ad esaurimento del vecchio

The new code will be supplied only when the old will be out of stock

Der neue Kode wird nur angegeben, wenn der alte nicht mehr lieferbar ist

Le nouveau code sera fourni uniquement lorsque le vieux stock sera écoulé

El nuevo código será suministrado sólo cuando se agoten las existencias del antiguo

O novo código irá ser fornecido apenas quando o antigo esgotar stock



* $F_{1i} =$

Isothermal end force at 100% Cu

Hand icon p. 16

** $F_{1p} =$

Polytrophic end force at 100% Cu

Hand icon p. 16



SW

ACTIVE SAFETY



OSAS



USAS



OPAS

N ₂		0 - 80 °C 32 - 176 °F	ΔP ± 0,33 %/°C	P max 200 bar 2900 psi	P min 20 bar 290 psi	S 24,63 cm ² 3.817 in ²	SPM ~ 30 - 70 (at 20°C)	Max Speed 1,6 m/s 62.9 in/s	Maintenance kit 39BMMML04700C	
CODE	NEW	Cu	L	L min	F ₀	F _{1i} *	F _{1p} **	V ₀	PED	
PHASING OUT from 05/2019		mm inch	mm inch	mm inch	Initial force daN lb	End force * daN lb	End force ** daN lb	cm ³ in ³	~Kg ~lb	2014/68/EU
ML4700-015-C-N	ML4700-015-D-N	15 0.59	120 4.72	105 4.13	4925 11071	6982 15697	7878 17711	158 9.64	2,34 5.16	✓
ML4700-025-C-N	ML4700-025-D-N	25 0.98	140 5.51	115 4.53	± 5%	7883 17721	9119 20500	204 12.46	2,51 5.53	✓
ML4700-038-C-N	ML4700-038-D-N	38 1.50	170 6.69	132 5.20	200 bar 2900 psi	8462 19023	9933 22330	277 16.88	2,75 6.06	✓
ML4700-050-C-N	ML4700-050-D-N	50 1.97	200 7.87	150 5.91		8683 19520	10247 23035	351 21.39	3,06 6.75	✓
ML4700-063-C-N	ML4700-063-D-N	63 2.48	230 9.06	167 6.57		8963 20150	10647 23936	423 25.82	3,33 7.34	✓
ML4700-080-C-N	ML4700-080-D-N	80 3.15	270 10.63	190 7.48	+20 °C +68 °F	9191 20663	10975 24673	520 31.74	3,70 8.16	✓

SERVICE BOX

code: 39SKML04700A



Seal (1x)



Washer (6x)



Screw (3x)



Instructions



Sostituire ogni 1.000.000 di cicli. REMPLACEZ À CHAQUE MILLION DE CYCLES.
 Replace every 1 million cycles. REEMPLAZAR CADA 1 MILLÓN DE CICLOS.
 Nach 1 Mio. Hübe austauschen. Substituir a cada 1 milhão de ciclos.

HOW TO ORDER

Hand icon p. 167

INSTALLATION GUIDELINE

Hand icon p. 205

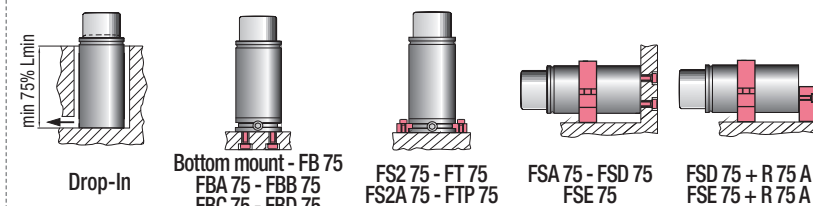



SW

ACTIVE SAFETY



OSAS



USAS



OPAS

Il nuovo codice sarà fornito solo ad esaurimento del vecchio

The new code will be supplied only when the old will be out of stock

Der neue Kode wird nur angegeben, wenn der alte nicht mehr lieferbar ist

Le nouveau code sera fourni uniquement lorsque le vieux stock sera écoulé

El nuevo código será suministrado sólo cuando se agoten las existencias del antiguo

O novo código irá ser fornecido apenas quando o antigo esgotar stock



* F_{1i} = Isothermal end force at 100% Cu p. 16

** F_{1p} = Polytrophic end force at 100% Cu p. 16

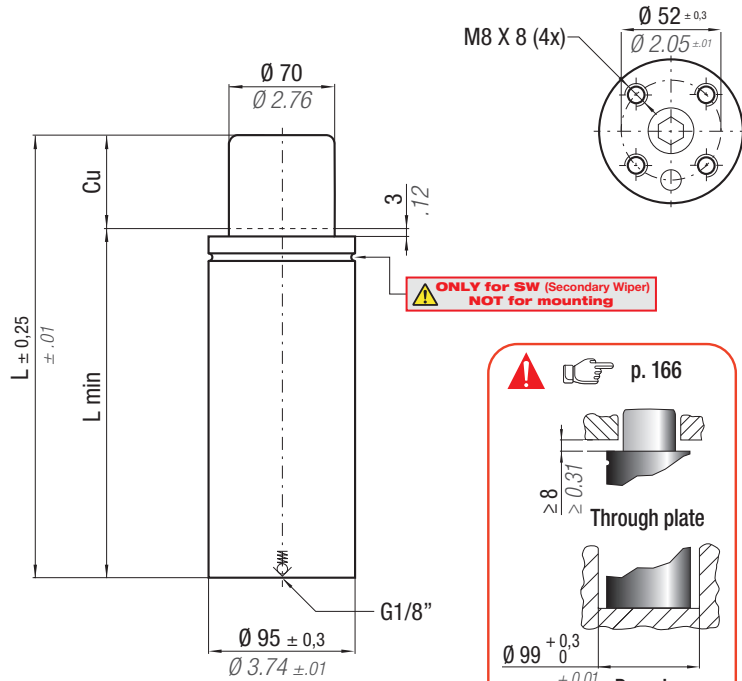

N ₂		0 - 80 °C 32 - 176 °F	ΔP ± 0,33 %/°C	P max 200 bar 2900 psi	P min 20 bar 290 psi	S 38,48 cm ² 5.964 in ²	SPM ~ 20 - 60 (at 20°C)	Max Speed 1,6 m/s 62.9 in/s	Maintenance kit 39BMMML07500C
CODE	NEW	Cu	L	L min	F ₀	F _{1i} *	F _{1p} **	V ₀	
PHASING OUT from 05/2019		mm inch	mm inch	mm inch	Initial force	End force *	End force **	cm ³ in ³	~Kg ~lb
ML 7500 - 015 - C	ML 7500 - 015 - D	15 0.59	115 4.53	100 3.94	7700 17310	10242 23024	11406 25641	295 17.98	3,30 7.28
ML 7500 - 025 - C	ML 7500 - 025 - D	25 0.98	135 5.31	110 4.33	± 5%	11442 25722	13037 29308	368 22.48	3,58 7.89
ML 7500 - 038 - C	ML 7500 - 038 - D	38 1.50	165 6.50	127 5.00	200 bar	12326 27709	14261 32060	484 29.56	4,01 8.84
ML 7500 - 050 - C	ML 7500 - 050 - D	50 1.97	190 7.48	140 5.51	2900 psi	13083 29411	15324 34449	578 35.27	4,36 9.61
ML 7500 - 063 - C	ML 7500 - 063 - D	63 2.48	220 8.66	157 6.18		13519 30391	15942 35838	694 42.34	4,75 10.47
ML 7500 - 080 - C	ML 7500 - 080 - D	80 3.15	260 10.24	180 7.09	+20 °C +68 °F	13883 31210	16462 37007	849 51.82	5,36 11.82

KIT FOR LINKING

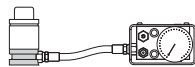

code: 39FML07500B



Seal (1x)



Washer (6x)



Screw (3x)



Bottom base (1x)



Valve (1x)



Instructions



Sostituire ogni 1.000.000 di cicli. Replace every 1 million cycles. Nach 1 Mio. Hübe austauschen. Reemplazar cada 1 millón de ciclos. Substituir a cada 1 milhão de ciclos.

Bottom base dimension

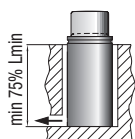
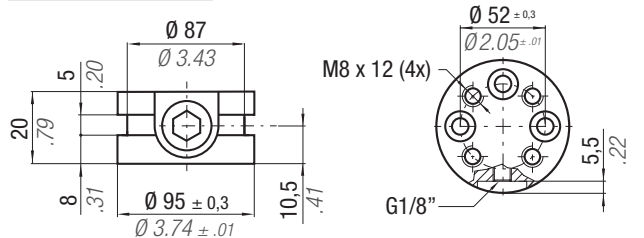

Drop-In



Bottom mount

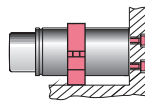

FSA 95 - FSD 95
FSE 95

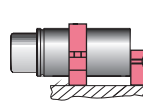

FSD 95 + R 95 A
FSE 95 + R 95 A

HOW TO ORDER

p. 167

INSTALLATION GUIDELINE

p. 205

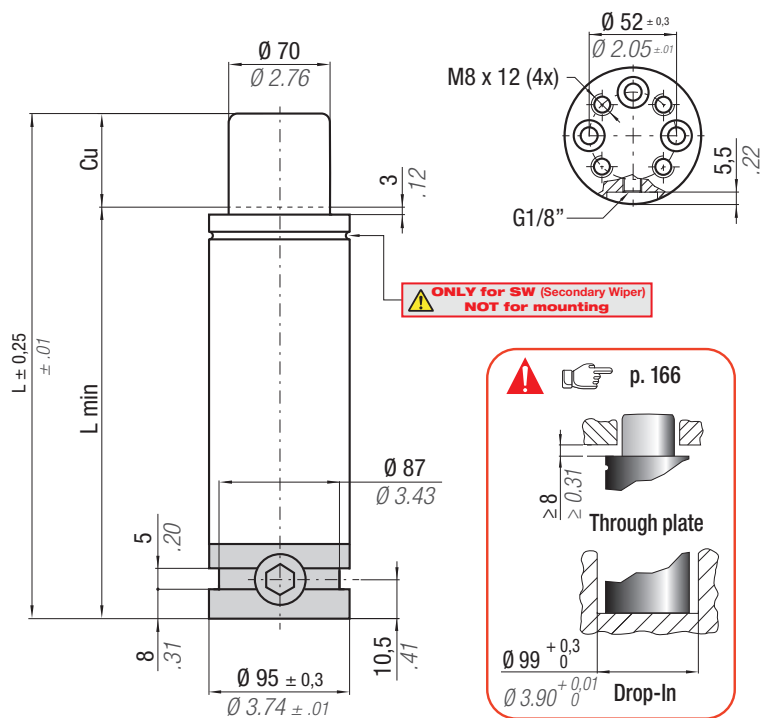

Il nuovo codice sarà fornito solo ad esaurimento del vecchio

The new code will be supplied only when the old will be out of stock

Der neue Kode wird nur angegeben, wenn der alte nicht mehr lieferbar ist

Le nouveau code sera fourni uniquement lorsque le vieux stock sera écoulé

El nuevo código será suministrado sólo cuando se agoten las existencias del antiguo

O novo código irá ser fornecido apenas quando o antigo esgotar stock



* $F_{1i} =$

Isothermal end force at 100% Cu

p. 16

** $F_{1p} =$

Polytrophic end force at 100% Cu



SW

ACTIVE SAFETY



OSAS



USAS



OPAS

N ₂		0 - 80 °C 32 - 176 °F	ΔP $\pm 0,33\%/^{\circ}C$	P max 200 bar 2900 psi	P min 20 bar 290 psi	S 38,48 cm ² 5.964 in ²	SPM ~ 20 - 60 (at 20°C)	Max Speed 1,6 m/s 62.9 in/s	Maintenance kit 39BMMML07500C
CODE	NEW	Cu	L	L min	F ₀	F _{1i} *	F _{1p} **	V ₀	
PHASING OUT from 05/2019		mm inch	mm inch	mm inch	Initial force daN lb	End force * daN lb	End force ** daN lb	cm ³ in ³	~Kg ~lb
ML7500-015-C-N	ML7500-015-D-N	15 0.59	135 5.31	120 4.72	7700 17310	10242 23024	11406 25641	295 17.98	4,32 9.52
ML7500-025-C-N	ML7500-025-D-N	25 0.98	155 6.10	130 5.12	$\pm 5\%$	11442 25722	13037 29308	368 22.48	4,60 10.14
ML7500-038-C-N	ML7500-038-D-N	38 1.50	185 7.28	147 5.79	200 bar 2900 psi	12326 27709	14261 32060	484 29.56	5,03 11.09
ML7500-050-C-N	ML7500-050-D-N	50 1.97	210 8.27	160 6.30		13083 29411	15324 34449	578 35.27	5,38 11.86
ML7500-063-C-N	ML7500-063-D-N	63 2.48	240 9.45	177 6.97		13519 30391	15942 35838	694 42.34	5,81 12.81
ML7500-080-C-N	ML7500-080-D-N	80 3.15	280 11.02	200 7.87	+20 °C +68 °F	13883 31210	16462 37007	849 51.82	6,39 14.09

SERVICE BOX

code: 39SKML04700A



Seal (1x)



Washer (6x)



Screw (3x)



Instructions



Sostituire ogni 1.000.000 di cicli. Replace every 1 million cycles. Nach 1 Mio. Hübe austauschen. Reemplazar a cada 1 millón de ciclos. Substituir a cada 1 milhão de ciclos.

HOW TO ORDER

p. 167

INSTALLATION GUIDELINE

p. 205

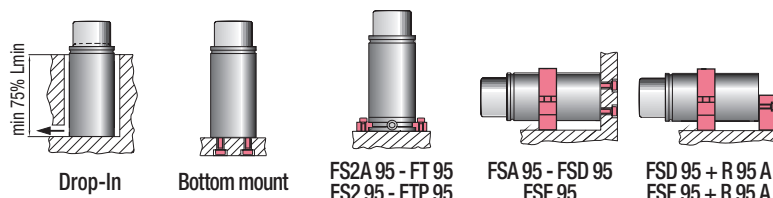



SW

Il nuovo codice sarà fornito solo ad esaurimento del vecchio
 The new code will be supplied only when the old will be out of stock

ACTIVE SAFETY



OSAS

Der neue Kode wird nur angegeben, wenn der alte nicht mehr lieferbar ist

Le nouveau code sera fourni uniquement lorsque le vieux stock sera écoulé

El nuevo código será suministrado sólo cuando se agoten las existencias del antiguo

O novo código irá ser fornecido apenas quando o antigo esgotar stock



USAS

easu MANIFOLD p. 247



OPAS

* F_{1i} = Isothermal end force at 100% Cu p. 16
 ** F_{1p} = Polytrophic end force at 100% Cu

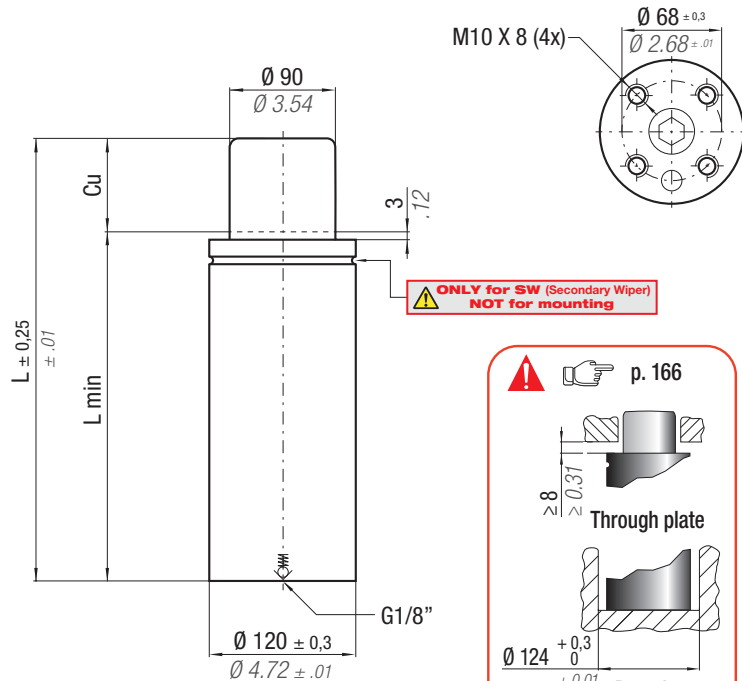

N ₂	0 - 80 °C 32 - 176 °F	ΔP ± 0,33 %/°C	P max 200 bar 2900 psi	P min 20 bar 290 psi	S 63,62 cm ² 9.861 in ²	SPM ~ 20 - 50 (at 20°C)	Max Speed 1,6 m/s 62.9 in/s	Maintenance kit 39BMML12000C									
CODE PHASING OUT from 05/2019	NEW	Cu	L	L min	F₀ Initial force	F_{1i} * End force *	F_{1p} ** End force **	V₀									
ML 12000 - 015 - C:ML 12000 - 015 - D	15	0.59	115	4.53	100	3.94	12720	28595	17910	40264	20179	45364	415	25.35	5,82	12,83	✓
ML 12000 - 025 - C:ML 12000 - 025 - D	25	0.98	135	5.31	110	4.33	± 5%		20260	45546	23413	52635	532	32.47	6,29	13,87	✓
ML 12000 - 038 - C:ML 12000 - 038 - D	38	1.50	165	6.50	127	5.00	200 bar		21844	49107	25639	57638	715	43.64	7,01	15,45	✓
ML 12000 - 050 - C:ML 12000 - 050 - D	50	1.97	195	7.68	145	5.71	2900 psi		22489	50558	26555	59699	902	55.05	7,74	17,06	✓
ML 12000 - 063 - C:ML 12000 - 063 - D	63	2.48	225	8.86	162	6.38	+20 °C		23275	52324	27678	62222	1085	66.22	8,46	18,65	✓
ML 12000 - 080 - C:ML 12000 - 080 - D	80	3.15	265	10.43	185	7.28	+68 °F		23928	53791	28617	64333	1331	81.19	9,43	20,79	✓

KIT FOR LINKING

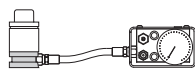

code: 39FML12000B



Seal (1x)



Washer (8x)



Screw (4x)



Bottom base (1x)



Valve (1x)



Instructions



Sostituire ogni 1.000.000 di cicli. Replace every 1 million cycles.
 Nach 1 Mio. Hübe austauschen.
 Remplacez à chaque million de cycles. Reemplazar cada 1 millón de ciclos.
 Substituir a cada 1 milhão de ciclos.

Bottom base dimension

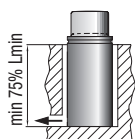
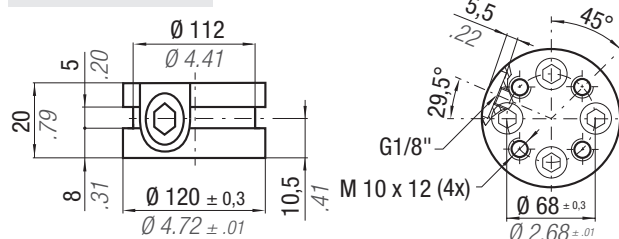

Drop-In



Bottom mount

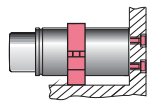

FSA 120 - FSD 120



HOW TO ORDER

p. 167

INSTALLATION GUIDELINE

p. 205

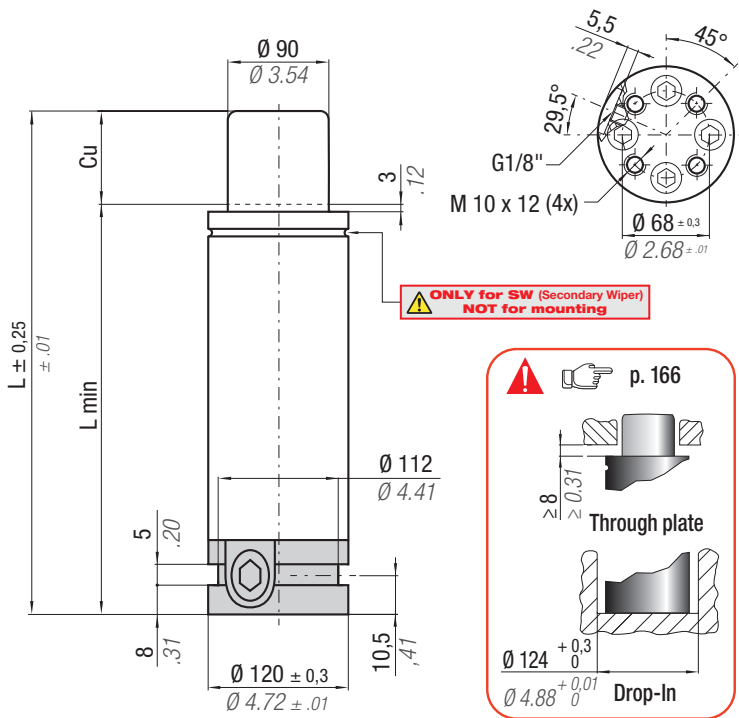

Il nuovo codice sarà fornito solo ad esaurimento del vecchio

The new code will be supplied only when the old will be out of stock

Der neue Kode wird nur angegeben, wenn der alte nicht mehr lieferbar ist

Le nouveau code sera fourni uniquement lorsque le vieux stock sera écoulé

El nuevo código será suministrado sólo cuando se agoten las existencias del antiguo

O novo código irá ser fornecido apenas quando o antigo esgotar stock



ACTIVE SAFETY



OSAS



USAS



OPAS



* F_{1i} =

Isothermal end force at 100% Cu



** F_{1p} =

Polytrophic end force at 100% Cu

N ₂		0 - 80 °C 32 - 176 °F	ΔP ± 0,33 %/°C	P max 200 bar 2900 psi	P min 20 bar 290 psi	S 63,62 cm ² 9,861 in ²	SPM ~ 20 - 50 (at 20°C)	Max Speed 1,6 m/s 62,9 in/s	Maintenance kit 39BMML12000C
CODE	NEW	Cu	L	L min	F ₀	F _{1i} *	F _{1p} **	V ₀	
PHASING OUT from 05/2019		mm inch	mm inch	mm inch	Initial force daN lb	End force * daN lb	End force ** daN lb	cm ³ in ³	~Kg ~lb
ML12000-015-C-N	ML12000-015-D-N	15 0.59	135 5.31	120 4.72	12720 28595	17910 40264	20179 45364	415 25.35	7,45 16.42
ML12000-025-C-N	ML12000-025-D-N	25 0.98	155 6.10	130 5.12	± 5%	20260 45546	23413 52635	532 32.47	7,92 17.46
ML12000-038-C-N	ML12000-038-D-N	38 1.50	185 7.28	147 5.79	200 bar 2900 psi	21844 49107	25639 57638	715 43.64	8,64 19.05
ML12000-050-C-N	ML12000-050-D-N	50 1.97	215 8.46	165 6.50		22489 50558	26555 59699	902 55.05	9,37 20.66
ML12000-063-C-N	ML12000-063-D-N	63 2.48	245 9.65	182 7.17		23275 52324	27678 62222	1085 66.22	10,09 22.24
ML12000-080-C-N	ML12000-080-D-N	80 3.15	285 11.22	205 8.07	+20 °C +68 °F	23928 53791	28617 64333	1331 81.19	11,06 24.38

SERVICE BOX

code: 39SKML12000A



Seal (1x)



Washer (8x)



Screw (4x)



Instructions



Sostituire ogni 1.000.000 di cicli. REMPLACEZ À CHAQUE MILLION DE CYCLES.
 Replace every 1 million cycles. REEMPLAZAR CADA 1 MILLÓN DE CICLOS.
 Nach 1 Mio. Hübe austauschen. Substituir a cada 1 milhão de ciclos.

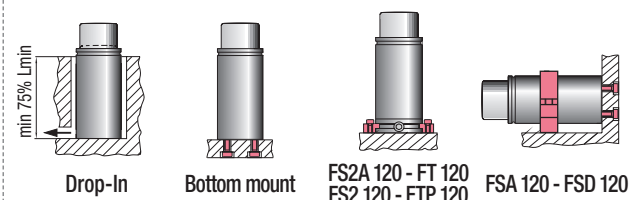

HOW TO ORDER

Icon pointing to p. 167

INSTALLATION GUIDELINE

Icon pointing to p. 205

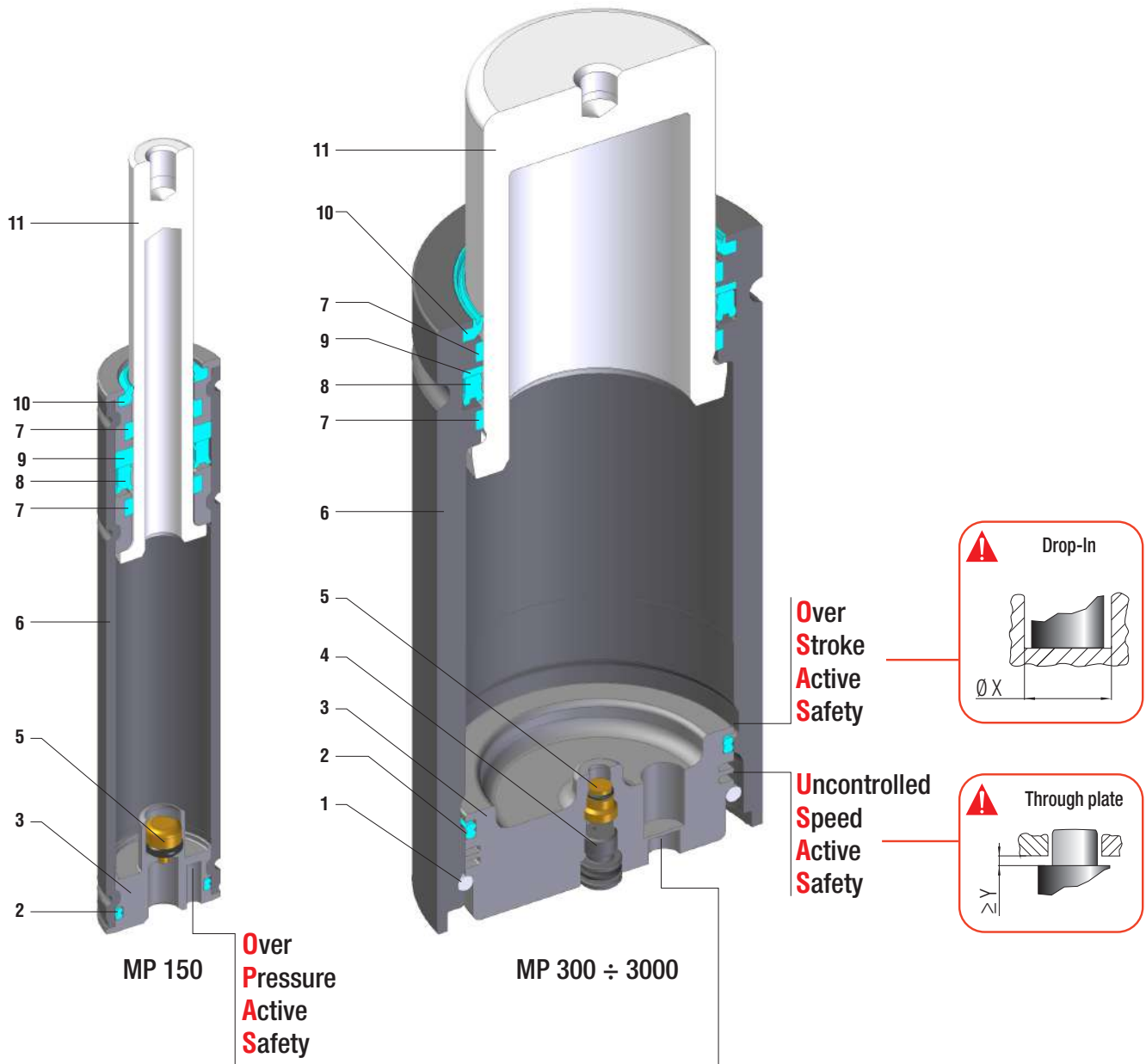

Massima forza, tenuta stelo - Maximum force, rod seal - Maximale Kraft, Kolbenstange dichtung
 Forces maximale, joint de tige - Máxima fuerza, estanqueidad vástago - Força máxima, estanquidade na haste

SEALING	ROD SEAL
DESIGN	BOTTOM BASE - BODY DESIGN

1	Retaining ring	5	Valve	9	Back-up ring
2	Dual ring seal	6	Body	10	Rod wiper
3	Bottom base	7	Guide ring	11	Rod (nitrited superfinished)
4	Plug	8	Rod seal		

RANGE CHART

Model	Body Ø		Stroke Cu		Initial force F0						
	mm	inch	mm	inch	daN	lb	OSAS	USAS	OPAS	SKUDO	SW
MP 150	19	0.75	10 - 80	0.39 - 3.15	150	337	-	-	✓	-	-
MP 300	25	0.98	10 - 80	0.39 - 3.15	300	674	✓	✓	-	-	-
MP 500	32	1.26	10 - 80	0.39 - 3.15	500	1124	✓	✓	-	-	✓
MP 1000	38	1.50	10 - 80	0.39 - 3.15	1000	2248	✓	✓	✓	-	✓
MP 2000	50	1.97	10 - 80	0.39 - 3.15	2000	4496	✓	✓	✓	-	-
MP 3000	63	2.48	10 - 80	0.39 - 3.15	3000	6744	✓	✓	✓	-	-

Built-in as standard
 Optional upon request

HOW TO ORDER

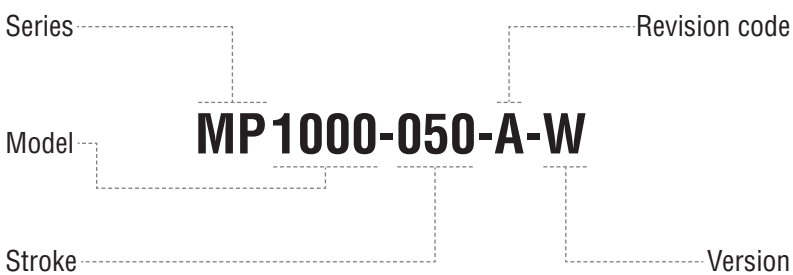

Available versions

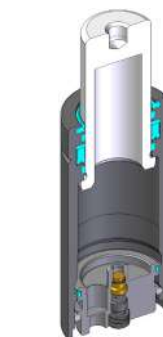

MP 1000-050-A
Standard code



Self contained



MP 1000-050-A-W
Add "-W" to standard code



Self contained



+
Secondary wiper

ACTIVE SAFETY



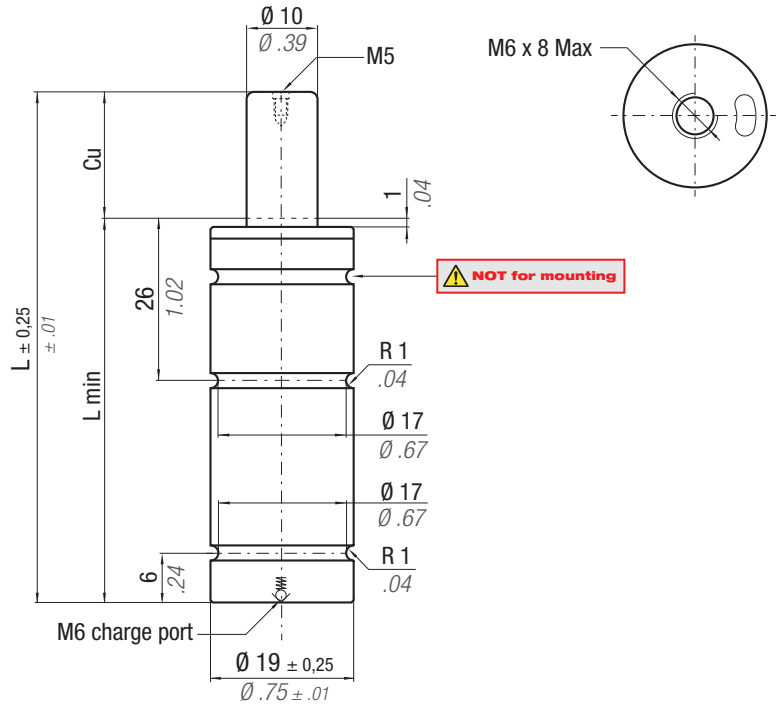

* $F_{1i} =$ Isothermal end force at 100% Cu  p. 16  ** $F_{1p} =$ Polytropic end force at 100% Cu

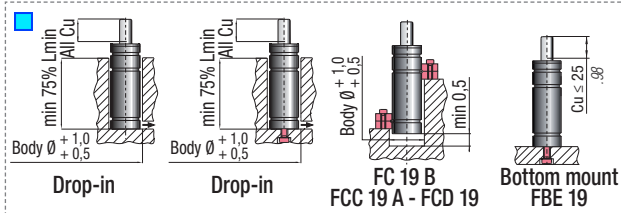

CODE	Cu		L		L min		F ₀		F _{1i} *		F _{1p} **		V ₀		Maintenance kit		
	mm	inch	mm	inch	mm	inch	daN	lb	daN	lb	daN	lb	cm ³	in ³	~Kg	~lb	
MP 150 - 010 - A	10	0.39	75	2.95	65	2.56	150 ± 5%	337	185	416	201	452	5,2	0.32	0,09	0.20	✓
MP 150 - 015 - A	15	0.59	85	3.35	70	2.76			195	438	214	481	6,4	0.39	0,09	0.20	✓
MP 150 - 020 - A	20	0.79	95	3.74	75	2.95			203	456	225	506	7,5	0.46	0,10	0.22	✓
MP 150 - 025 - A	25	0.98	105	4.13	80	3.15			209	470	234	526	8,6	0.52	0,11	0.24	✓
MP 150 - 032 - A	32	1.26	120	4.72	88	3.46			214	481	241	542	10,4	0.63	0,11	0.24	✓
MP 150 - 038 - A	38	1.50	135	5.31	97	3.82			214	481	241	542	12,4	0.76	0,12	0.26	✓
MP 150 - 045 - A	45	1.77	150	5.91	105	4.13			217	488	245	551	14,1	0.86	0,13	0.29	✓
MP 150 - 050 - A	50	1.97	160	6.30	110	4.33			220	495	249	560	15,3	0.93	0,14	0.31	✓
MP 150 - 056 - A	56	2.20	175	6.89	119	4.69			219	492	248	558	17,2	1.05	0,14	0.31	✓
MP 150 - 063 - A	63	2.48	190	7.48	127	5.00			221	497	251	564	19,0	1.16	0,15	0.33	✓
MP 150 - 080 - A	80	3.15	220	8.66	140	5.51	231	519	264	593	22,0	1.34	0,17	0.37	✓		



HOW TO ORDER
 p. 183

INSTALLATION GUIDELINE
 p. 205

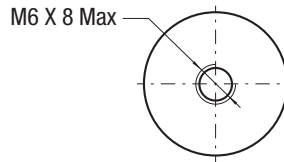
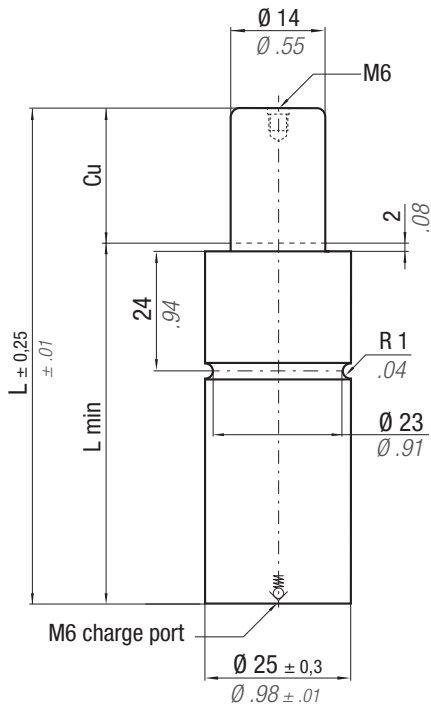

* F_{1i} =
Isothermal
end force
at 100% Cu



p. 16

** F_{1p} =
Polytropic
end force
at 100% Cu

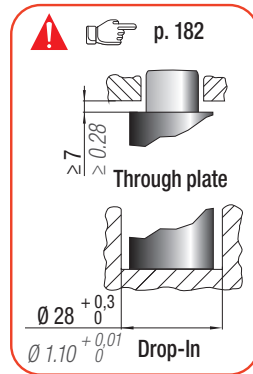

ACTIVE SAFETY



OSAS



USAS

CODE	Cu		L		L min		F ₀		F _{1i} *		F _{1p} **		V ₀		Maintenance kit		
	mm	inch	mm	inch	mm	inch	daN	lb	daN	lb	daN	lb	cm ³	in ³	~Kg	~lb	
MP 300 - 010 - A	10	0.39	75	2.95	65	2.56	300 ± 5% 195 bar 2828 psi + 20 °C +68 °F	674	430	966	481	1082	6,4	0,39	0,17	0,37	✓
MP 300 - 015 - A	15	0.59	85	3.35	70	2.76			466	1047	531	1193	8,2	0.50	0,18	0.40	✓
MP 300 - 020 - A	20	0.79	95	3.74	75	2.95			492	1107	568	1277	9,8	0.60	0,20	0.44	✓
MP 300 - 025 - A	25	0.98	105	4.13	80	3.15			513	1153	597	1342	11,5	0.70	0,21	0.46	✓
MP 300 - 032 - A	32	1.26	120	4.72	88	3.46			527	1185	617	1387	14,1	0.86	0,23	0.51	✓
MP 300 - 038 - A	38	1.50	135	5.31	97	3.82			522	1173	610	1371	17,0	1.04	0,25	0.55	✓
MP 300 - 045 - A	45	1.77	150	5.91	105	4.13			531	1194	623	1400	19,6	1.20	0,27	0.60	✓
MP 300 - 050 - A	50	1.97	160	6.30	110	4.33			540	1214	636	1429	21,3	1.30	0,28	0.62	✓
MP 300 - 056 - A	56	2.20	175	6.89	119	4.69			535	1202	628	1412	24,1	1.47	0,30	0.66	✓
MP 300 - 063 - A	63	2.48	190	7.48	127	5.00			540	1215	636	1430	26,7	1.63	0,32	0.71	✓
MP 300 - 080 - A	80	3.15	225	8.86	145	5.71	556	1250	658	1480	32,7	1.99	0,36	0.79	✓		

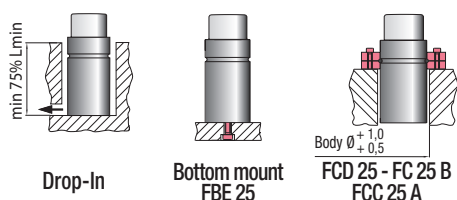

HOW TO ORDER

p. 183

INSTALLATION GUIDELINE

p. 205



ACTIVE SAFETY



OSAS



USAS

* $F_{1i} =$

Isothermal end force at 100% Cu



p. 16



** $F_{1p} =$

Polytropic end force at 100% Cu

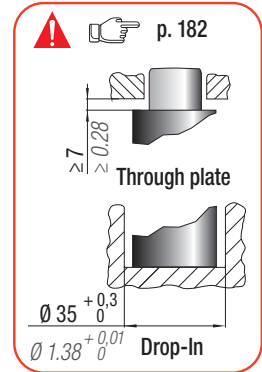
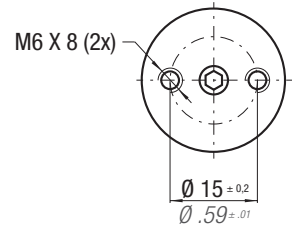
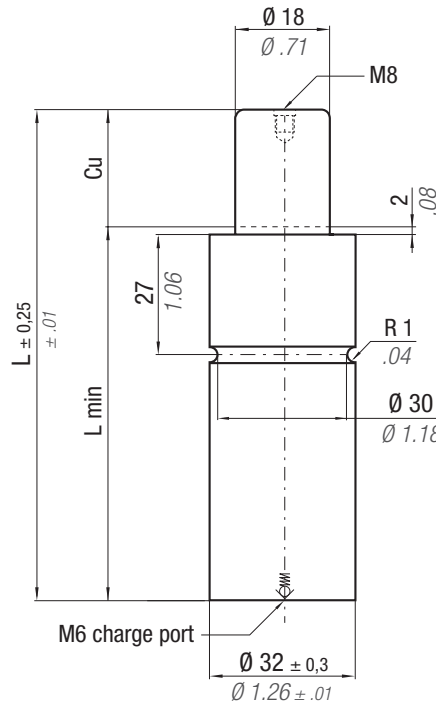

CODE	N ₂	0 - 80 °C 32 - 176 °F	ΔP ± 0,33 %/°C	P max 197 bar 2857 psi	P min 20 bar 290 psi	S 2,54 cm ² 0,394 in ²	SPM ~ 40 - 80 (at 20°C)	Max Speed 1,6 m/s 62,9 in/s	Maintenance kit Disposable	Cu	L	L min	F ₀		F _{1i} *		F _{1p} **		V ₀		PED		
													Initial force daN	lb	daN	lb	daN	lb	cm ³	in ³	~Kg	~lb	2014/68/EU
MP 500 - 010 - A										10	75	65	500 ± 5%	1124	714	1605	798	798	10,7	0,65	0,29	0,64	✓
MP 500 - 015 - A									15	85	70	770			1731	873	873	13,6	0,83	0,31	0,68	✓	
MP 500 - 020 - A									20	95	75	809			1819	928	928	16,5	1,01	0,33	0,73	✓	
MP 500 - 025 - A									25	105	80	839			1886	970	970	19,5	1,19	0,34	0,75	✓	
MP 500 - 032 - A									32	120	88	859			1931	997	997	24,1	1,47	0,37	0,82	✓	
MP 500 - 038 - A									38	135	97	849			1909	984	984	29,1	1,78	0,40	0,88	✓	
MP 500 - 045 - A									45	150	105	862			1938	1002	1002	33,6	2,05	0,43	0,95	✓	
MP 500 - 050 - A									50	160	110	875			1967	1020	1020	36,6	2,23	0,45	0,99	✓	
MP 500 - 056 - A									56	175	119	866			1947	1008	1008	41,6	2,54	0,48	1,06	✓	
MP 500 - 063 - A									63	195	132	844			1897	977	977	48,6	2,96	0,52	1,15	✓	
MP 500 - 080 - A									80	230	150	869	1954	1012	1012	59,1	3,61	0,59	1,30	✓			

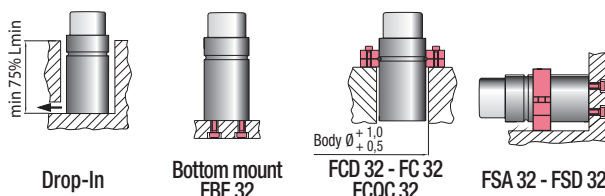

HOW TO ORDER

p. 183

INSTALLATION GUIDELINE

p. 205



ACTIVE SAFETY



OSAS



USAS



OPAS

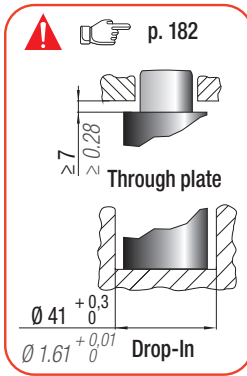
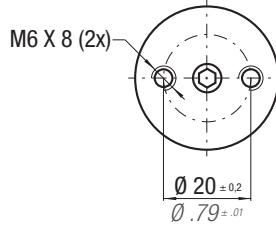
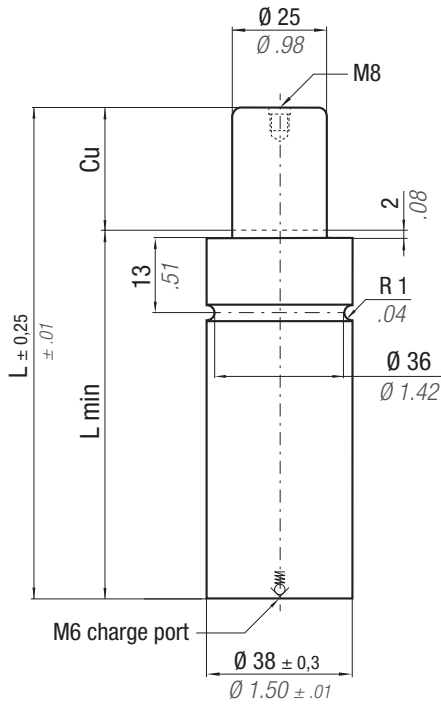

* $F_{1i} =$

Isothermal end force at 100% Cu



p. 16

** $F_{1p} =$

Polytropic end force at 100% Cu



	0 - 80 °C 32 - 176 °F	ΔP ± 0,33 %/°C	P max 205 bar 2973 psi	P min 20 bar 290 psi	S 4,91 cm ² 0.761 in ²	SPM ~ 40 - 80 (at 20°C)	Max Speed 1,6 m/s 62.9 in/s	Maintenance kit 39BMMP01000A
--	--------------------------	---------------------------	-------------------------------------	-----------------------------------	-----------------------------------------------------------	--------------------------------------	------------------------------------------	----------------------------------------

CODE	Cu		L		L min		F ₀ Initial force		F _{1i} * End force *		F _{1p} ** End force **		V ₀		Maintenance kit		PED 2014/68/EU
	mm	inch	mm	inch	mm	inch	daN	lb	daN	lb	daN	lb	cm ³	in ³	~Kg	~lb	
MP 1000 - 010 - A	10	0.39	75	2.95	65	2.56	1000 ± 5%	2248	1418	3188	1591	3577	21,5	1.31	0,37	0.82	✓
MP 1000 - 015 - A	15	0.59	85	3.35	70	2.76			1547	3478	1765	3968	26,5	1.62	0,39	0.86	✓
MP 1000 - 020 - A	20	0.79	95	3.74	75	2.95			1647	3703	1902	4276	31,6	1.93	0,41	0.90	✓
MP 1000 - 025 - A	25	0.98	105	4.13	80	3.15			1727	3882	2012	4523	36,6	2.23	0,44	0.97	✓
MP 1000 - 032 - A	32	1.26	120	4.72	88	3.46			1792	4029	2103	4728	44,4	2.71	0,48	1.06	✓
MP 1000 - 038 - A	38	1.50	135	5.31	97	3.82			1792	4029	2103	4728	52,7	3.21	0,51	1.12	✓
MP 1000 - 045 - A	45	1.77	150	5.91	105	4.13			1833	4121	2161	4858	60,6	3.70	0,55	1.21	✓
MP 1000 - 050 - A	50	1.97	160	6.3	110	4.33			1870	4204	2213	4975	65,6	4.00	0,58	1.28	✓
MP 1000 - 056 - A	56	2.20	175	6.89	119	4.69			1861	4184	2200	4946	73,9	4.51	0,62	1.37	✓
MP 1000 - 063 - A	63	2.48	205	8.07	142	5.59			1716	3858	1998	4492	93,1	5.68	0,70	1.54	✓
MP 1000 - 080 - A	80	3.15	240	9.45	160	6.30	1792	4029	2104	4730	111	6.77	0,79	1.74	✓		

MP

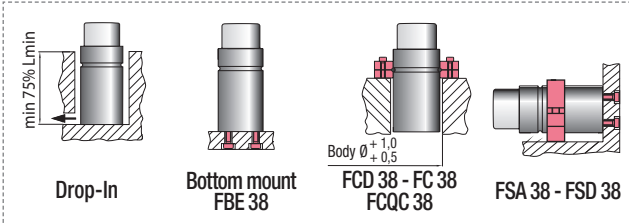

HOW TO ORDER
 p. 183

INSTALLATION GUIDELINE
 p. 205

ACTIVE SAFETY



OSAS



USAS



OPAS

* F_{1i} =
Isothermal
end force
at 100% Cu



p. 16



** F_{1p} =
Polytropic
end force
at 100% Cu

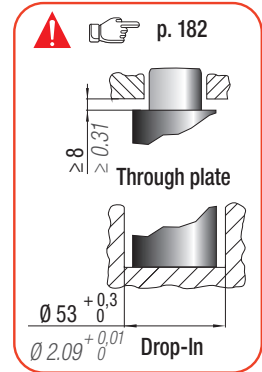
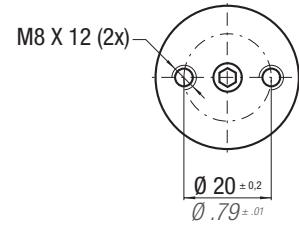
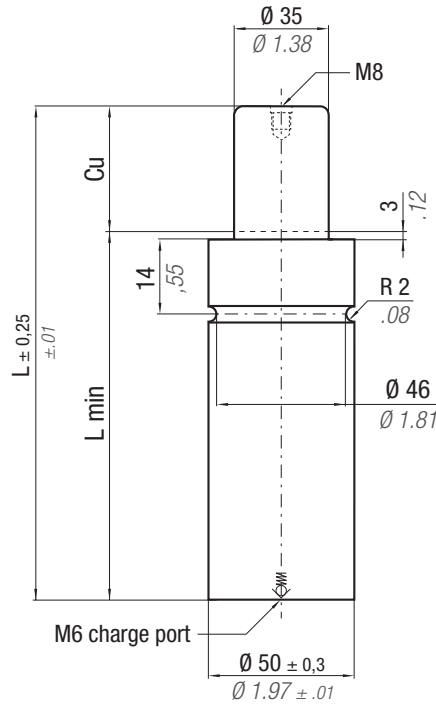

CODE	N ₂	0 - 80 °C 32 - 176 °F	ΔP ± 0,33 %/°C	P max 209 bar 3031 psi	P min 20 bar 290 psi	S 9,62 cm ² 1.491 in ²	SPM ~ 40 - 80 (at 20°C)	Max Speed 1,6 m/s 62.9 in/s	Maintenance kit 39BMMP02000A	PED 2014/68/EU	Cu		L		L min		F ₀		F _{1i} *		F _{1p} **		V ₀		~Kg	~lb	✓		
											mm	inch	mm	inch	mm	inch	daN	lb	daN	lb	daN	lb	cm ³	in ³					
MP 2000 - 010 - A											10	0.39	90	3.54	80	3.15	2000 ± 5%	4496	209 bar 3031 psi	+ 20 °C +68 °F	2634	5921	2902	6524	52,4	3.20	0,76	1,68	✓
MP 2000 - 015 - A										15	0.59	115	4.53	100	3.94	2617					5883	2880	6474	80,4	4.90	0,89	1,96	✓	
MP 2000 - 020 - A										20	0.79	125	4.92	105	4.13	2775					6238	3088	6942	89,6	5.47	0,93	2,05	✓	
MP 2000 - 025 - A										25	0.98	135	5.31	110	4.33	2916					6555	3276	7365	98,7	6.02	0,98	2,16	✓	
MP 2000 - 032 - A										32	1.26	150	5.91	118	4.65	3074					6911	3487	7839	112,8	6.88	1,04	2,29	✓	
MP 2000 - 038 - A										38	1.50	165	6.50	127	5.00	3153					7088	3593	8077	127,5	7.78	1,11	2,45	✓	
MP 2000 - 045 - A										45	1.77	180	7.09	135	5.31	3269					7349	3751	8433	141,6	8.64	1,18	2,60	✓	
MP 2000 - 050 - A										50	1.97	190	7.48	140	5.51	3355					7542	3868	8696	150,7	9.19	1,22	2,69	✓	
MP 2000 - 056 - A										56	2.20	205	8.07	149	5.87	3398					7639	3926	8826	165,5	10.10	1,29	2,84	✓	
MP 2000 - 063 - A										63	2.48	220	8.66	157	6.18	3480					7823	4039	9080	179,5	10.95	1,36	3.00	✓	
MP 2000 - 080 - A										80	3.15	255	10.04	175	6.89	3668	8246	4299	9665	211,9	12.93	1,51	3.33	✓					

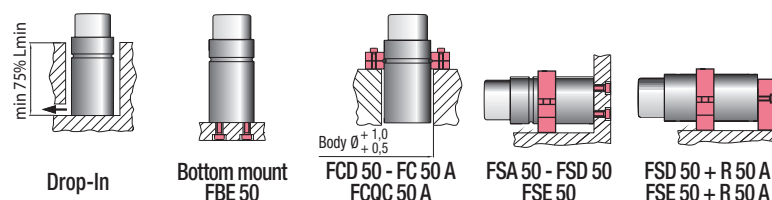

HOW TO ORDER

p. 183

INSTALLATION GUIDELINE

p. 205



ACTIVE SAFETY



OSAS



USAS



OPAS

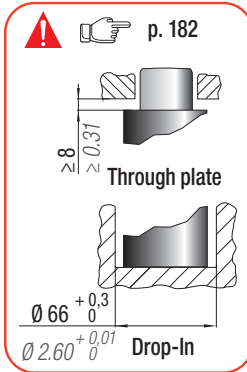
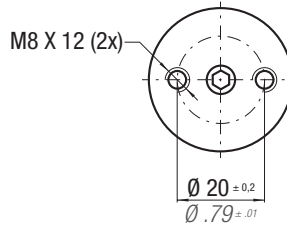
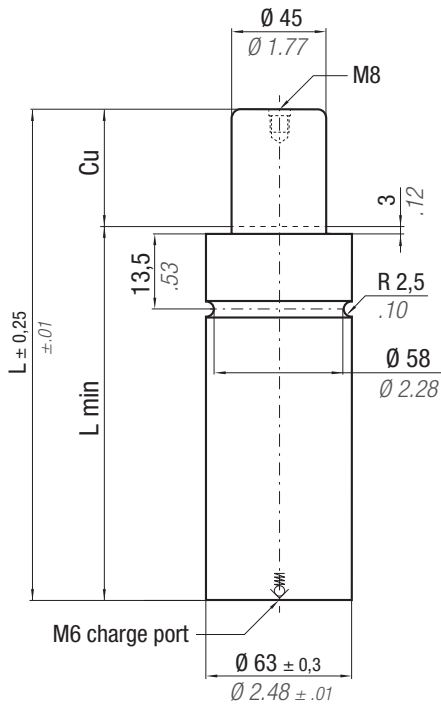

* $F_{1i} =$

Isothermal end force at 100% Cu



p. 16

** $F_{1p} =$

Polytrophic end force at 100% Cu



CODE	Cu	L	L min	F ₀		F _{1i} *		F _{1p} **		V ₀		Maintenance kit		
				Initial force	End force *	End force **	cm ³	in ³	~Kg	~lb				
MP 3000 - 010 - A	10	95	85	3000 ± 5%	6744	3792	8525	4150	9330	96,0	5.86	1,25	2.76	✓
MP 3000 - 015 - A	15	115	100			3877	8716	4263	9584	132,7	8.09	1,40	3.09	✓
MP 3000 - 020 - A	20	125	105			4099	9215	4567	10267	148,1	9.03	1,46	3.22	✓
MP 3000 - 025 - A	25	135	110			4298	9662	4840	10881	163,6	9.98	1,52	3.35	✓
MP 3000 - 032 - A	32	150	118			4516	10152	5145	11566	187,3	11.43	1,62	3.57	✓
MP 3000 - 038 - A	38	165	127			4622	10391	5294	11901	212,2	12.94	1,72	3.79	✓
MP 3000 - 045 - A	45	180	135			4781	10748	5519	12407	235,9	14.39	1,82	4.01	✓
MP 3000 - 050 - A	50	190	140			4898	11011	5686	12783	251,3	15.33	1,89	4.17	✓
MP 3000 - 063 - A	63	220	157			5065	11387	5926	13322	299,9	18.29	2,08	4.59	✓
MP 3000 - 080 - A	80	255	175			5319	11958	6292	14145	354,5	21.62	2,31	5.09	✓

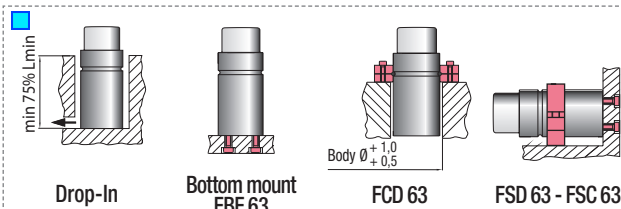

HOW TO ORDER

Hand icon p. 183

INSTALLATION GUIDELINE

Hand icon p. 205

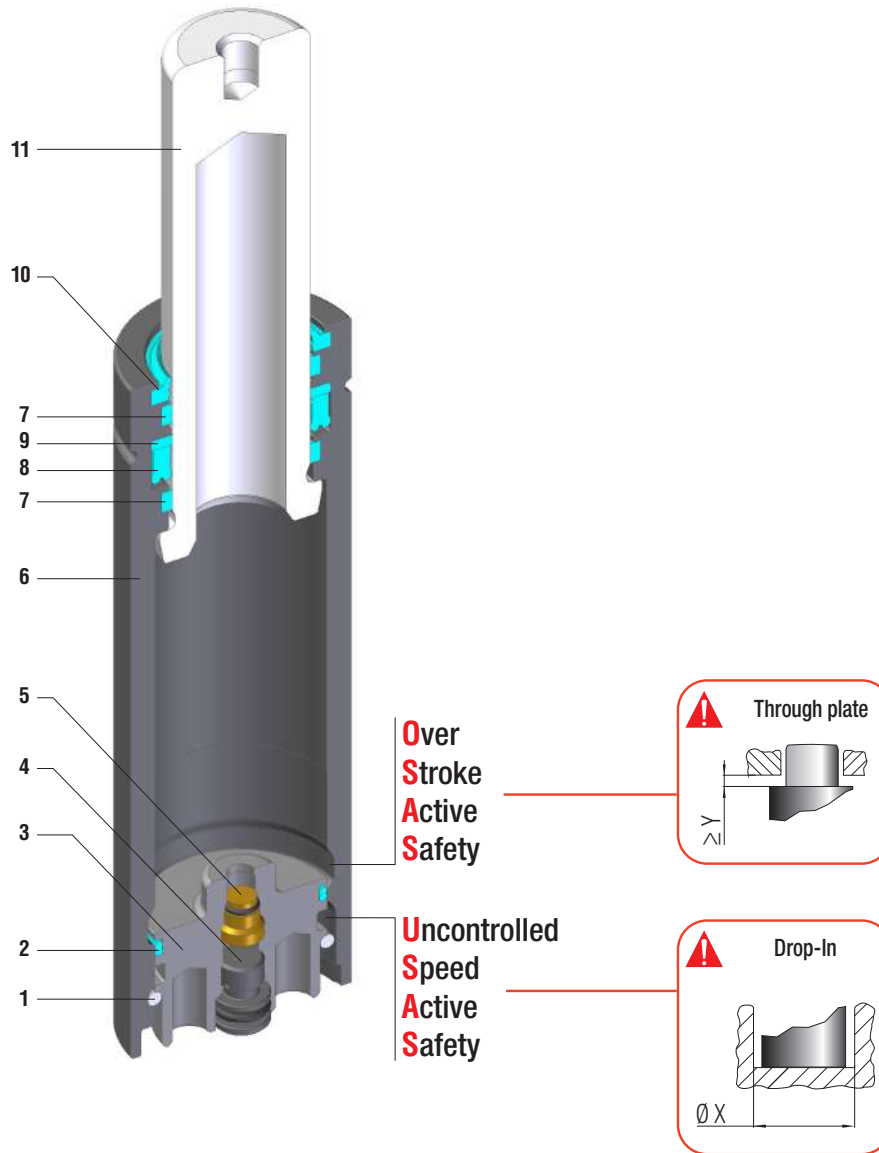

**Over
Stroke
Active
Safety**

**Uncontrolled
Speed
Active
Safety**

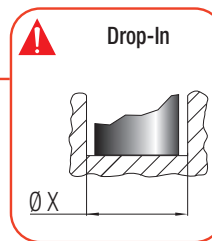
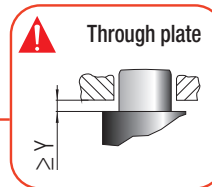





$\varnothing 32$ | Massima forza, tenuta stelo - Maximum force, rod seal - Maximale Kraft, Kolbenstange dichtung
Forces maximale, joint de tige - Máxima fuerza, estanqueidad vástago - Força máxima, estanquidade na haste

SEALING	ROD SEAL
DESIGN	BOTTOM BASE - BODY DESIGN

1	Retaining ring	5	Valve	9	Back-up ring
2	Dual ring seal	6	Body	10	Rod wiper
3	Bottom base	7	Guide ring	11	Rod (nitrited superfinished)
4	Plug	8	Rod seal		

RANGE CHART

Model	Body Ø		Stroke Cu		Initial force F0		OSAS	USAS	OPAS	SKUDO	SW
	mm	inch	mm	inch	daN	lb					
MQ 700	32	1.26	10 - 80	0.39 - 3.15	660	1484	✓	✓	-	-	-

✓ Built-in as standard
✓ Optional upon request

HOW TO ORDER



Available version

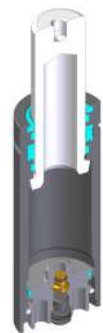

MQ 700-050-A
Standard code



Self contained

MQ

ACTIVE SAFETY



OSAS



USAS

* $F_{1i} =$
Isothermal
end force
at 100% Cu



p. 16



** $F_{1p} =$
Polytrophic
end force
at 100% Cu

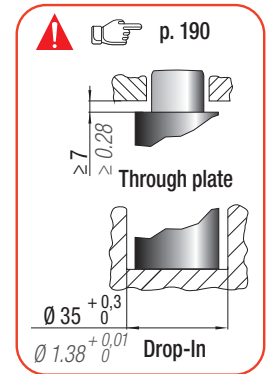
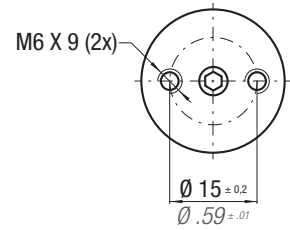
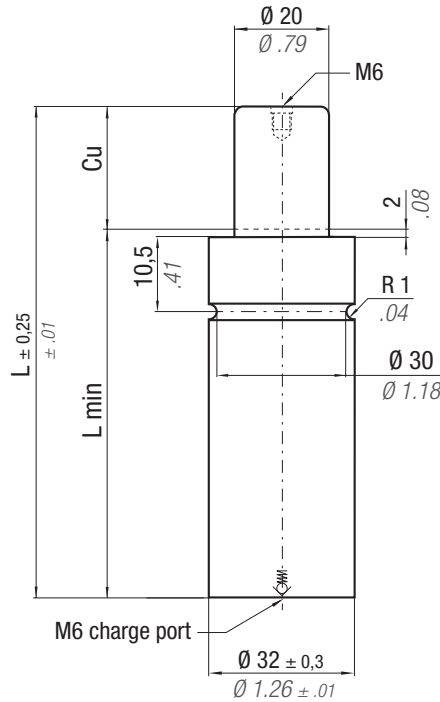

CODE	N ₂	0 - 80 °C 32 - 176 °F	ΔP ± 0,33 %/°C	P max 210 bar 3045 psi	P min 20 bar 290 psi	S 3,14 cm ² 0,487 in ²	SPM ~ 40 - 80 (at 20°C)	Max Speed 1,6 m/s 62.9 in/s	Maintenance kit Disposable	Cu	L	L min	F ₀		F _{1i} *		F _{1p} **		V ₀		~Kg	~lb	PED 2014/68/ED
													Initial force daN	lb	daN	lb	daN	lb	cm ³	in ³			
MQ 700 - 010 - A										10	75	65	660 ± 5%	1484	1020	2293	1158	2603	11,3	0,69	0,29	0,64	✓
MQ 700 - 015 - A									15	85	70	1120			2517	1293	2907	14,4	0,88	0,31	0,68	✓	
MQ 700 - 020 - A									20	95	75	1193			2683	1395	3135	17,5	1,07	0,33	0,73	✓	
MQ 700 - 025 - A									25	105	80	1250			2810	1473	3312	20,6	1,26	0,35	0,77	✓	
MQ 700 - 032 - A									32	120	88	1288			2896	1527	3432	25,5	1,56	0,38	0,84	✓	
MQ 700 - 038 - A									38	135	97	1272			2861	1505	3383	30,7	1,87	0,41	0,90	✓	
MQ 700 - 045 - A									45	150	105	1297			2916	1539	3461	35,6	2,17	0,44	0,97	✓	
MQ 700 - 050 - A									50	160	110	1322			2972	1575	3540	38,7	2,36	0,46	1,01	✓	
MQ 700 - 056 - A									56	175	119	1307			2937	1553	3490	43,9	2,68	0,49	1,08	✓	
MQ 700 - 063 - A									63	195	132	1266			2846	1496	3363	51,2	3,12	0,53	1,17	✓	
MQ 700 - 080 - A									80	315	230	1314	2954	1563	3515	62,3	3,80	0,60	1,32	✓			

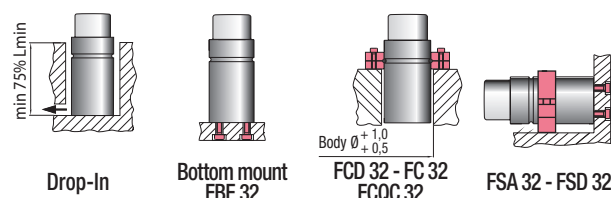

HOW TO ORDER

p. 191

INSTALLATION GUIDELINE

p. 205



THIS PAGE IS INTENTIONALLY LEFT BLANK

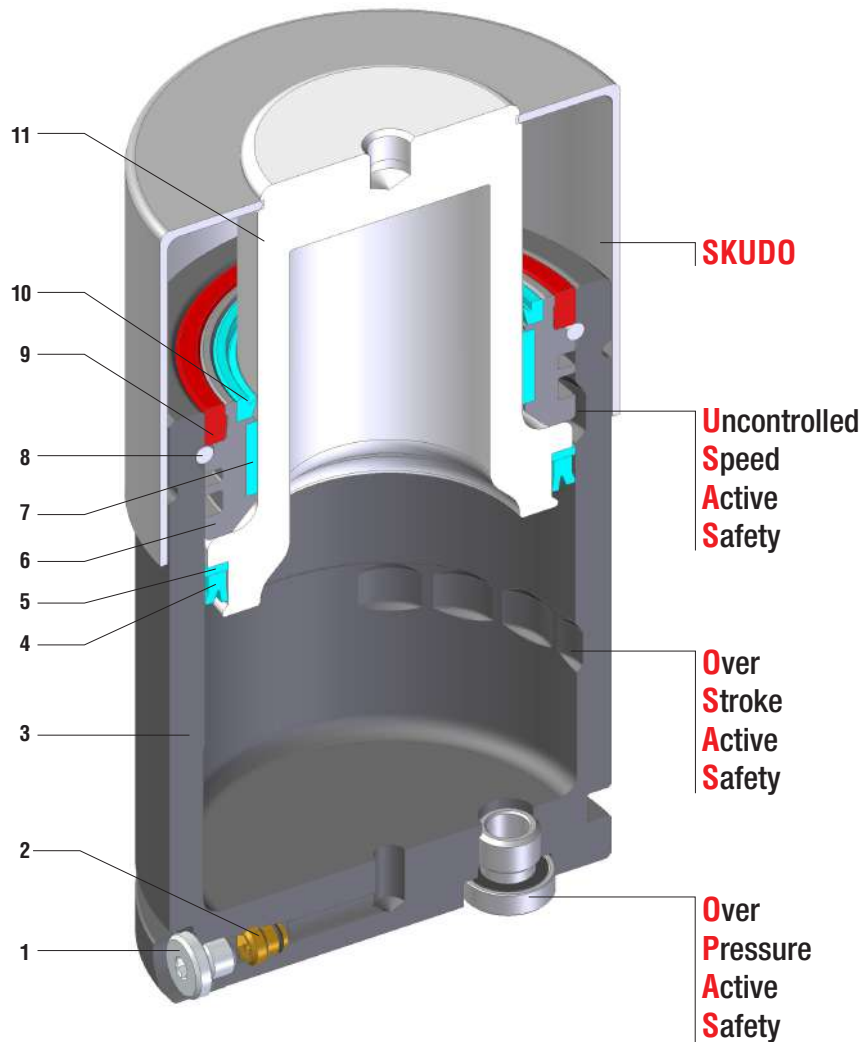

Massima forza, tenuta pistone + SKUDO - Maximum force, piston seal + SKUDO - Maximale Kraft, Kolbendichtung + SKUDO - Force maximale, piston étanche + SKUDO - Máxima fuerza, estanqueidad pistón + SKUDO - Força máxima, estanquidade no pistão + SKUDO

SEALING	PISTON SEAL
DESIGN	PISTON - BODY DESIGN

1	Plug	5	Back-up ring	9	Outer seal
2	Valve	6	Bush	10	Rod wiper
3	Body	7	Guide ring	11	Rod (nitrited superfinished)
4	Piston seal	8	Retaining ring		

RANGE CHART

Model	Body Ø		Stroke Cu		Initial force F0						
	mm	inch	mm	inch	daN	lb					
KE 400	25	0.98	6 - 50	0.39 - 1.97	425	955	-	-	-	✓	✓*
KE 750	32	1.26	6 - 50	0.39 - 1.97	740	1664	✓	✓	✓	✓	✓
KE 1000	38	1.50	6 - 50	0.24 - 1.97	1060	2383	✓	✓	✓	✓	✓
KE 1800	50	1.97	6 - 65	0.24 - 1.97	1885	4238	✓	✓	✓	✓	✓
KE 3000	63	2.48	10 - 65	0.39 - 1.97	2945	6620	✓	✓	✓	✓	✓
KE 4700	75	2.95	10 - 65	0.39 - 1.97	4675	10510	✓	✓	✓	✓	✓
KE 7500	95	3.74	10 - 65	0.39 - 1.97	7540	16950	✓	✓	✓	✓	✓
KE 12000	120	4.72	10 - 65	0.39 - 1.97	11780	26481	✓	✓	✓	✓	✓
KE 18500	150	5.91	10 - 65	0.39 - 1.97	18410	41386	✓	✓	✓	✓	✓

* Skudo must be removed

✓ Built-in as standard

✓ Optional upon request

HOW TO ORDER

Series _____ Revision code _____

Model **KE4700-050-B-ED-W**

Stroke _____ Version _____

Available versions

KE 4700-050-B Standard code	KE 4700-050-B-W Add "-W" to standard code	KE 4700-050-B-N Add "-N" to standard code	KE 4700-050-B-N-W Add "-N-W" to standard code	KE 4700-050-B-ED Add "-ED" to standard code	KE 4700-050-B-ED-W Add "-ED-W" to standard code
Self contained	Self contained + Secondary wiper	Linkable	Linkable + Secondary wiper	Easy Manifold	Easy Manifold + Secondary wiper

KE



SW
Skudo must be removed

p. 262

ACTIVE SAFETY

* $F_{1i} =$

Isothermal end force at 100% Cu p. 16

** $F_{1p} =$

Polytropic end force at 100% Cu



SKUDO

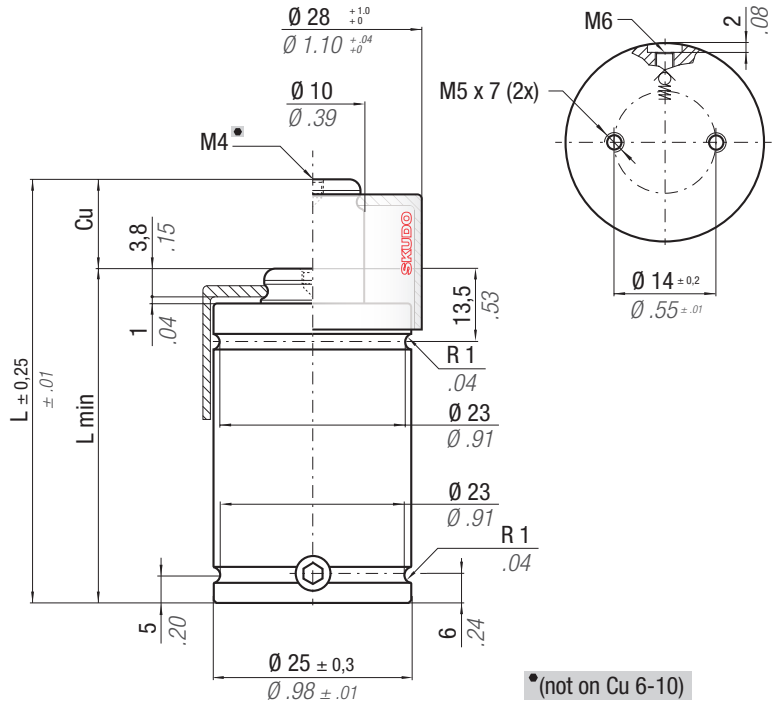

CODE	Cu	L	L min	F ₀		F _{1i} *		F _{1p} **		V ₀		Maintenance kit		
				Initial force	End force *	End force **	cm ³	in ³	~Kg	~lb				
KE 400 - 006 - A	6	56	50	425 955 ± 5%	792	1780	1016	2285	4,2	0,26	0,13	0,29	✓	
KE 400 - 010 - A	10	70	60		881	1980	1170	2631	6,2	0,38	0,16	0,35	✓	
KE 400 - 016 - A	16	91	75		888	1997	1183	2660	9,8	0,60	0,18	0,40	✓	
KE 400 - 025 - A	25	120	95		150 bar	878	1974	1166	2621	15,5	0,95	0,23	0,51	✓
KE 400 - 032 - A	32	140	108		2175psi	911	2047	1223	2750	19,2	1,17	0,24	0,53	✓
KE 400 - 040 - A	40	165	125		+ 20 °C +68 °F	910	2045	1222	2746	24,0	1,46	0,28	0,62	✓
KE 400 - 050 - A	50	195	145			921	2070	1241	2791	29,7	1,81	0,31	0,68	✓

Upside down mounting

FC / FCC fixings

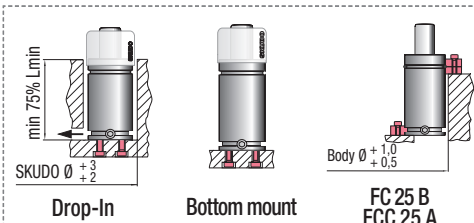

HOW TO ORDER

p. 195

INSTALLATION GUIDELINE

p. 205



SW

ACTIVE SAFETY



OSAS



USAS



OPAS



SKUDO

Il nuovo codice sarà fornito solo ad esaurimento del vecchio

The new code will be supplied only when the old will be out of stock

Der neue Kode wird nur angegeben, wenn der alte nicht mehr lieferbar ist

Le nouveau code sera fourni uniquement lorsque le vieux stock sera écoulé

El nuevo código será suministrado sólo cuando se agoten las existencias del antiguo

O novo código irá ser fornecido apenas quando o antigo esgotar stock



p. 247



p. 262

* $F_{1i} =$

Isothermal end force at 100% Cu



p. 16

** $F_{1p} =$

Polythropic end force at 100% Cu

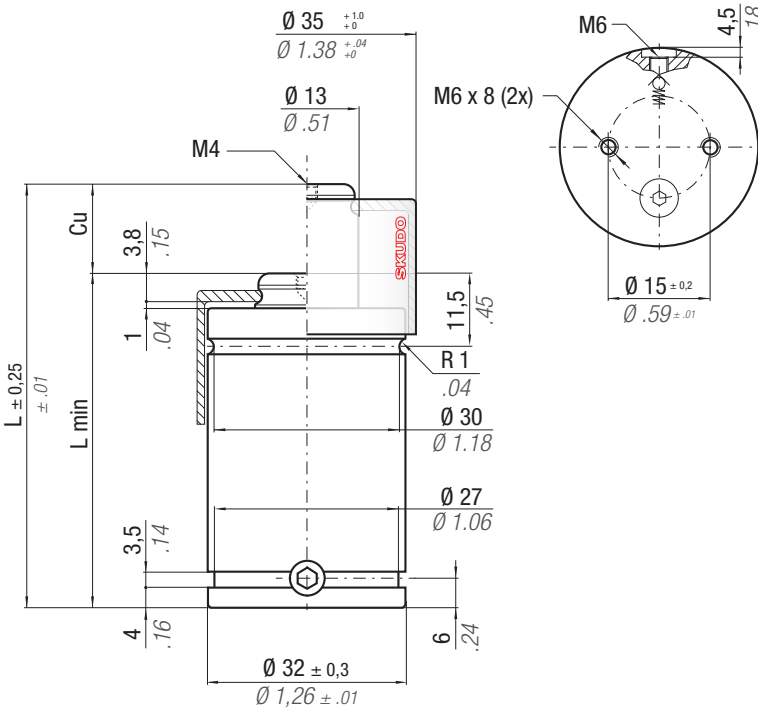

	$0 - 80^{\circ}\text{C}$ $32 - 176^{\circ}\text{F}$	ΔP $\pm 0,33\% / ^{\circ}\text{C}$	P max 150 bar 2175 psi	P min 20 bar 290 psi	S 4,91 cm ² 0.761 in ²	SPM ~ 50 - 100 (at 20°C)	Max Speed 0,8 m/s 31.5 in/s	Maintenance kit 39BMKE00750B
--	--------------------------------------------------------	-----------------------------------------------	-------------------------------------	-----------------------------------	-----------------------------------------------------------	---------------------------------------	------------------------------------------	----------------------------------------

CODE	Cu		L		L min		F ₀		F _{1i} *		F _{1p} **		V ₀		PED		
	mm	inch	mm	inch	mm	inch	daN	lb	daN	lb	daN	lb	cm ³	in ³	~Kg	~lb	2014/68/EU
KE 750 - 006 - B	6	0.24	63	2.48	57	2.24	740	1664	1214	2729	1497	3365	8,6	0.52	0,23	0.51	✓
KE 750 - 010 - B	10	0.39	75	2.95	65	2.56	150 bar 2175psi	± 5%	1316	2958	1666	3745	12,7	0.78	0,25	0.55	✓
KE 750 - 016 - B	16	0.63	93	3.66	77	3.03			1395	3136	1800	4047	18,9	1.15	0,29	0.64	✓
KE 750 - 025 - B	25	0.98	120	4.72	95	3.74	1453	3267	1901	4273	28,2	1.72	0,33	0.73	✓		
KE 750 - 032 - B	32	1.26	140	5.51	108	4.25	1498	3369	1980	4452	34,9	2.13	0,37	0.82	✓		
KE 750 - 040 - B	40	1.57	165	6.50	125	4.92	1498	3369	1980	4450	43,7	2.67	0,42	0.92	✓		
KE 750 - 050 - B	50	1.97	195	7.68	145	5.71	+ 20 °C + 68 °F		1515	3405	2008	4515	54,0	3.30	0,47	1.04	✓

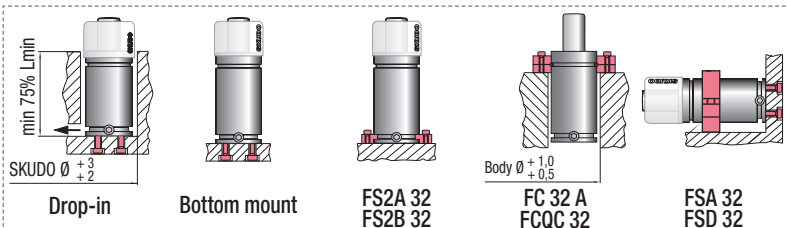
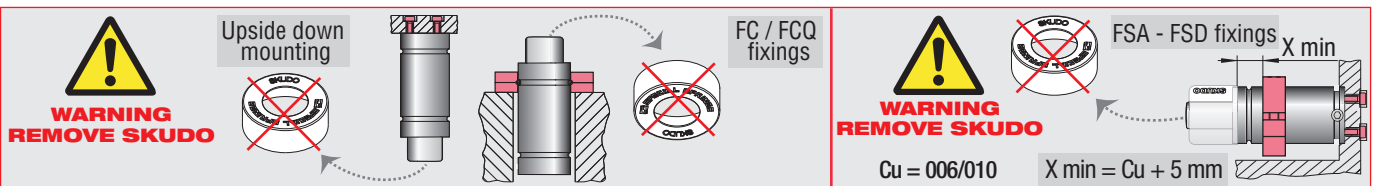

HOW TO ORDER
p. 195

INSTALLATION GUIDELINE
p. 205



SW

Il nuovo codice sarà fornito solo ad esaurimento del vecchio
 The new code will be supplied only when the old will be out of stock

ACTIVE SAFETY



OSAS

Der neue Kode wird nur angegeben, wenn der alte nicht mehr lieferbar ist



USAS

Le nouveau code sera fourni uniquement lorsque le vieux stock sera écoulé

El nuevo código será suministrado sólo cuando se agoten las existencias del antiguo

O novo código irá ser fornecido apenas quando o antigo esgotar stock



OPAS

eASU MANIFOLD p. 247

p. 262



SKUDO

* $F_{1i} =$
 Isothermal
 end force at 100% Cu p. 16

** $F_{1p} =$
 Polytrophic
 end force at 100% Cu

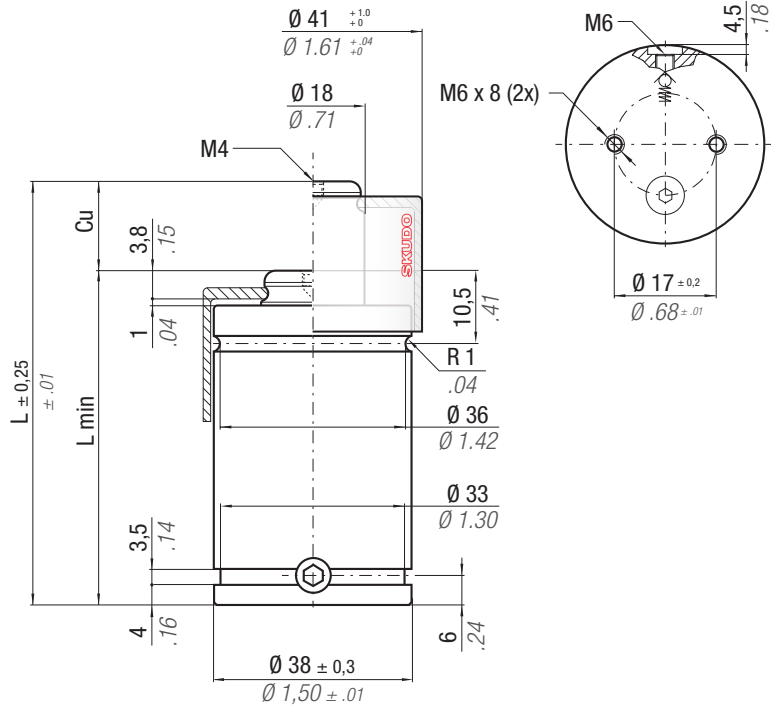

	0 - 80 °C 32 - 176 °F	ΔP ± 0,33 %/°C	P max 150 bar 2175 psi	P min 20 bar 290 psi	S 7,07 cm ² 1.096 in ²	SPM ~ 50 - 100 (at 20°C)	Max Speed 0,8 m/s 31.5 in/s	Maintenance kit 39BMKE01000B
--	--------------------------	---------------------------	-------------------------------------	-----------------------------------	-----------------------------------------------------------	---------------------------------------	------------------------------------------	----------------------------------------

CODE	Cu		L		L min		F ₀		F _{1i} *		F _{1p} **		V ₀		~Kg		~lb		PED 2014/68/EU
	mm	inch	mm	inch	mm	inch	daN	lb	daN	lb	daN	lb	cm ³	in ³					
◆ KE 1000 - 006 - B	6	0.24	61	2.40	55	2.17	1060 2383 ± 5%		1936	4351	2468	5547	10,7	0.65	0,33	0.72	✓		
KE 1000 - 010 - B	10	0.39	78	3.07	68	2.68			1851	4160	2325	5226	18,9	1.15	0,38	0.84	✓		
KE 1000 - 016 - B	16	0.63	100	3.94	84	3.31			1824	4100	2280	5126	30,9	1.89	0,44	0.97	✓		
KE 1000 - 025 - B	25	0.98	135	5.31	110	4.33			1775	3990	2199	4944	50,3	3.07	0,53	1.17	✓		
KE 1000 - 032 - B	32	1.26	167	6.57	135	5.31			1704	3832	2084	4686	68,8	4.20	0,63	1.39	✓		
KE 1000 - 040 - B	40	1.57	195	7.68	155	6.10			1730	3890	2126	4780	83,8	5.11	0,70	1.54	✓		
KE 1000 - 050 - B	50	1.97	230	9.06	180	7.09	+ 20 °C +68 °F	1753	3940	2163	4862	102,6	6.26	0,79	1.74	✓			

◆ Disposable

WARNING REMOVE SKUDO

Upside down mounting

FC / FCQ fixings

WARNING REMOVE SKUDO

FSA - FSD fixings X min

Cu = 006 / 010 X min = Cu + 5 mm

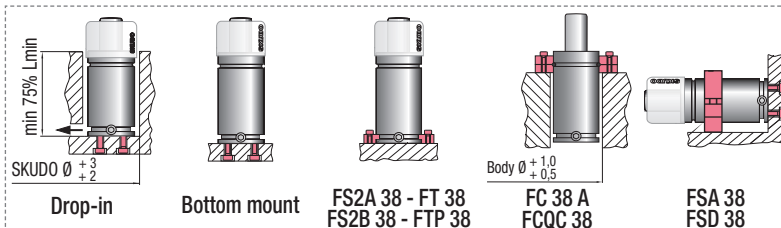

HOW TO ORDER

p. 195

INSTALLATION GUIDELINE

p. 205



SW

ACTIVE SAFETY



OSAS



USAS



OPAS



SKUDO

Il nuovo codice sarà fornito solo ad esaurimento del vecchio

The new code will be supplied only when the old will be out of stock

Der neue Kode wird nur angegeben, wenn der alte nicht mehr lieferbar ist

Le nouveau code sera fourni uniquement lorsque le vieux stock sera écoulé

El nuevo código será suministrado sólo cuando se agoten las existencias del antiguo

O novo código irá ser fornecido apenas quando o antigo esgotar stock



p. 247



p. 262

* $F_{1i} =$

Isothermal end force at 100% Cu



p. 16

** $F_{1p} =$

Polytropic end force at 100% Cu

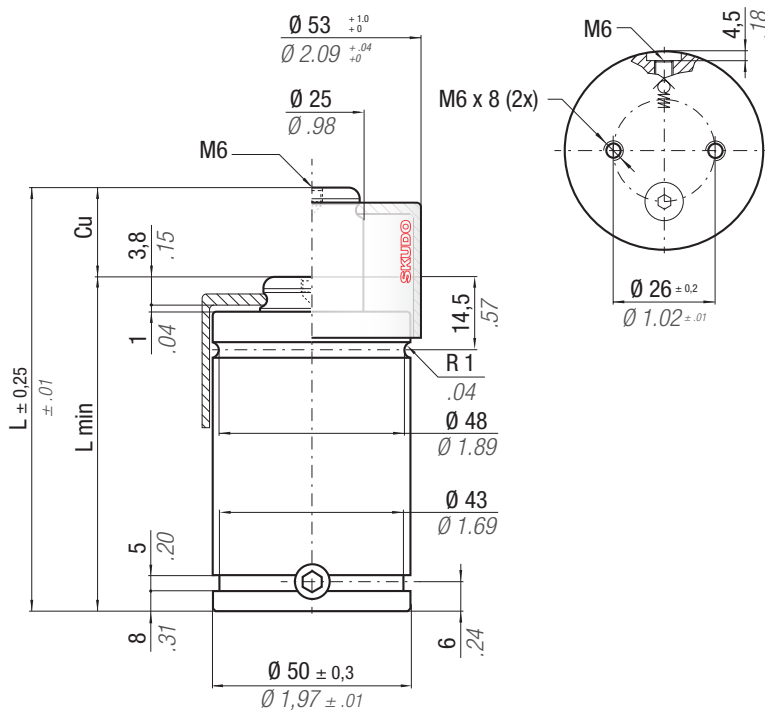

CODE	N ₂	0 - 80 °C 32 - 176 °F	ΔP $\pm 0,33\%/^{\circ}C$	P max 150 bar 2175 psi	P min 20 bar 290 psi	S 12,57 cm ² 1.948 in ²	SPM ~ 50 - 100 (at 20°C)	Max Speed 0,8 m/s 31.5 in/s	Maintenance kit 39BMKE01800B	Cu		L		L min		F ₀		F _{1i} *		F _{1p} **		V ₀		PED		
										mm	inch	mm	inch	mm	inch	daN	lb	daN	lb	daN	lb	cm ³	in ³	~Kg	~lb	2014/68/EU
KE 1800 - 006 - B										6	0.24	66	2.60	60	2.36	1885	4238	3026	6804	3699	8316	23,0	1.40	0,63	1.39	✓
KE 1800 - 010 - B										10	0.39	80	3.15	70	2.76	$\pm 5\%$	3112	6996	3839	8629	36,6	2.23	0,69	1.52	✓	
KE 1800 - 016 - B										16	0.63	106	4.17	90	3.54		2973	6683	3612	8121	63,2	3.86	0,81	1.79	✓	
KE 1800 - 025 - B										25	0.98	135	5.31	110	4.33	150 bar 2175psi	3128	7032	3865	8689	90,6	5.53	0,94	2.07	✓	
KE 1800 - 032 - B										32	1.26	162	6.38	130	5.12		3102	6974	3823	8594	117,6	7.18	1,06	2.34	✓	
KE 1800 - 040 - B										40	1.57	190	7.48	150	5.91		3132	7041	3872	8704	144,7	8.83	1,19	2.62	✓	
KE 1800 - 050 - B										50	1.97	220	8.66	170	6.69	+ 20 °C +68 °F	3233	7267	4038	9077	172,4	10.52	1,31	2.89	✓	
KE 1800 - 065 - B										65	2.56	271	10.67	206	8.11		3259	7327	4082	9177	221,5	13.52	1,53	3.37	✓	

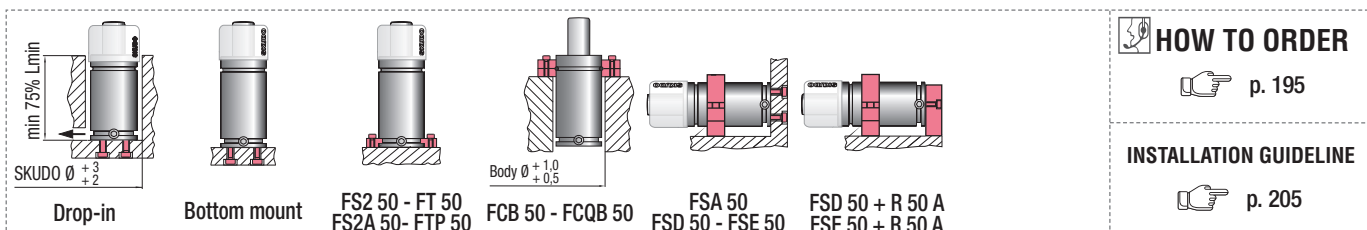
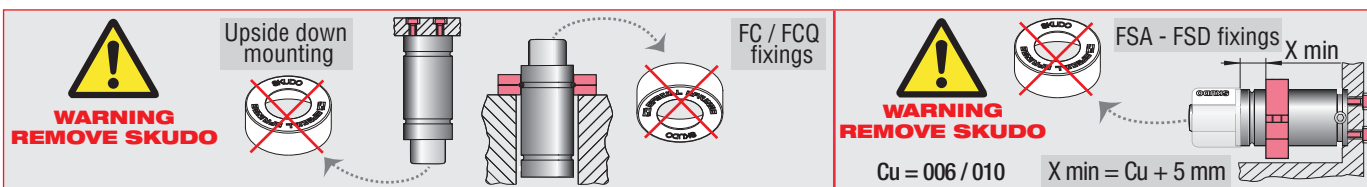



SW

ACTIVE SAFETY



OSAS



USAS



OPAS



SKUDO

Il nuovo codice sarà fornito solo ad esaurimento del vecchio

The new code will be supplied only when the old will be out of stock

Der neue Kode wird nur angegeben, wenn der alte nicht mehr lieferbar ist

Le nouveau code sera fourni uniquement lorsque le vieux stock sera écoulé

El nuevo código será suministrado sólo cuando se agoten las existencias del antiguo

O novo código irá ser fornecido apenas quando o antigo esgotar stock

easU MANIFOLD p. 247

p. 262

* F_{1i} =
Isothermal
end force
at 100% Cu p. 16

** F_{1p} =
Polythropic
end force
at 100% Cu

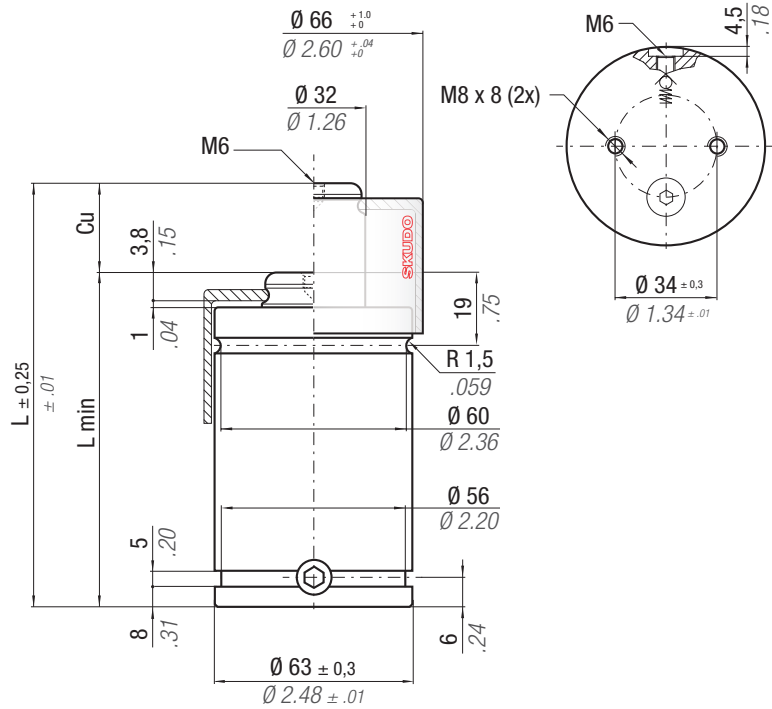

CODE	Cu	L	L min	F ₀		F _{1i} *		F _{1p} **		V ₀		Maintenance kit		
				Initial force	End force *	End force **	cm ³	in ³	~Kg	~lb				
KE 3000 - 010 - B	10	85	75	2945	6620	5028	11304	6271	14099	54	3.31	1,23	2.71	✓
KE 3000 - 016 - B	16	103	87	± 5%		5317	11953	6754	15184	80	4.90	1,36	3.00	✓
KE 3000 - 025 - B	25	130	105	150 bar	2175 psi	5532	12436	7119	16004	119	7.29	1,55	3.42	✓
KE 3000 - 032 - B	32	150	118	+ 20 °C	+ 68 °F	5691	12794	7392	16618	148	9.02	1,69	3.73	✓
KE 3000 - 040 - B	40	175	135			5698	12810	7404	16645	185	11.26	1,86	4.10	✓
KE 3000 - 050 - B	50	205	155			5758	12945	7508	16878	228	13.91	2,07	4.56	✓
KE 3000 - 065 - B	65	256	191			5616	12626	7263	16328	305	18.61	2,44	5.38	✓

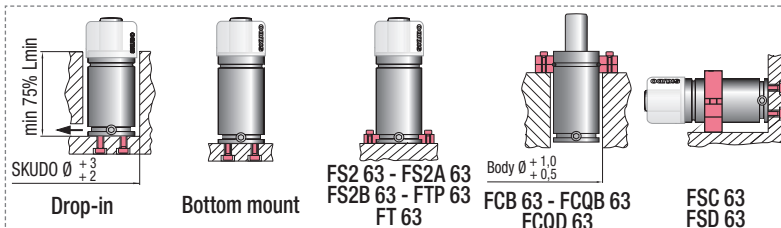
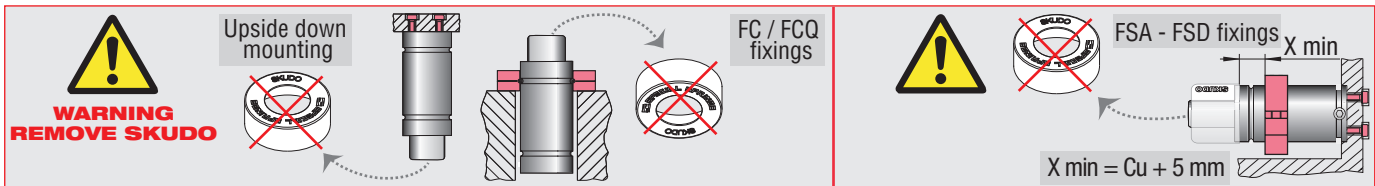

HOW TO ORDER

p. 195

INSTALLATION GUIDELINE

p. 205



ACTIVE SAFETY

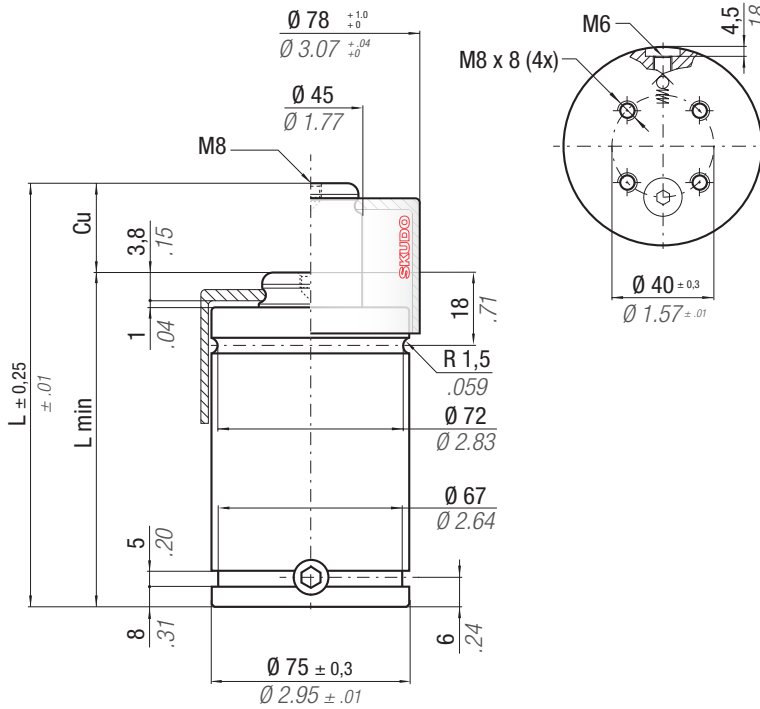

Il nuovo codice sarà fornito solo ad esaurimento del vecchio

The new code will be supplied only when the old will be out of stock

Der neue Kode wird nur angegeben, wenn der alte nicht mehr lieferbar ist

Le nouveau code sera fourni uniquement lorsque le vieux stock sera écoulé

El nuevo código será suministrado sólo cuando se agoten las existencias del antiguo

O novo código irá ser fornecido apenas quando o antigo esgotar stock



p. 247



p. 262

* F_{1i} =

Isothermal end force at 100% Cu



p. 16

** F_{1p} =

Polytropic end force at 100% Cu



CODE	Cu		L		L min		F ₀		F _{1i} *		F _{1p} **		V ₀		Maintenance kit		
	mm	inch	mm	inch	mm	inch	daN	lb	daN	lb	daN	lb	cm ³	in ³	~Kg	~lb	
KE 4700 - 010 - B	10	0.39	80	3.15	70	2.76	4675	10510	8001	17986	9986	22449	86	5.24	1,62	3.57	✓
KE 4700 - 016 - B	16	0.63	106	4.17	90	3.54			7460	16771	9100	20458	154	9.37	1,85	4.08	✓
KE 4700 - 025 - B	25	0.98	135	5.31	110	4.33	150 bar	2175 psi	7775	17478	9613	21611	224	13.68	2,10	4.63	✓
KE 4700 - 032 - B	32	1.26	167	6.57	135	5.31			7444	16734	9074	20398	308	18.82	2,39	5.27	✓
KE 4700 - 040 - B	40	1.57	200	7.87	160	6.30	+ 20 °C	+68 °F	7358	16541	8935	20086	394	24.02	2,68	5.91	✓
KE 4700 - 050 - B	50	1.97	240	9.45	190	7.48			7323	16464	8879	19962	496	30.28	3,03	6.68	✓
KE 4700 - 065 - B	65	2.56	273	10.75	208	8.19	7924	17813	9858	22162	566	34.53	3,30	7.28	✓		

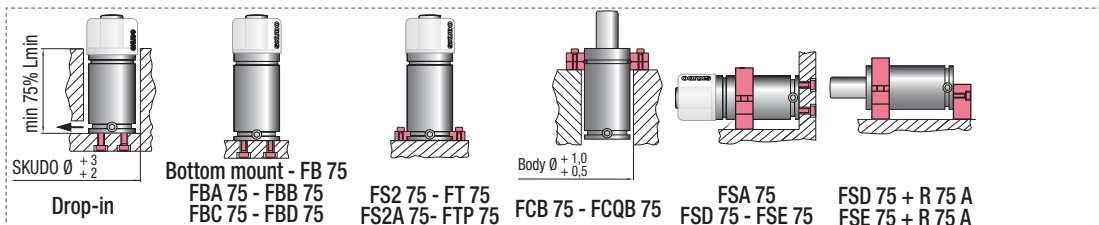
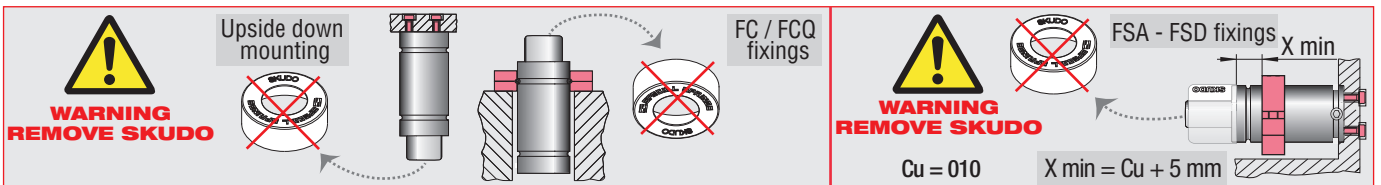

HOW TO ORDER

p. 195

INSTALLATION GUIDELINE

p. 205



SW

ACTIVE SAFETY



OSAS



USAS



OPAS



SKUDO

Il nuovo codice sarà fornito solo ad esaurimento del vecchio

The new code will be supplied only when the old will be out of stock

Der neue Kode wird nur angegeben, wenn der alte nicht mehr lieferbar ist

Le nouveau code sera fourni uniquement lorsque le vieux stock sera écoulé

El nuevo código será suministrado sólo cuando se agoten las existencias del antiguo

O novo código irá ser fornecido apenas quando o antigo esgotar stock

easU MANIFOLD p. 247

p. 262

* $F_{1i} =$
Isothermal
end force
at 100% Cu p. 16

** $F_{1p} =$
Polythropic
end force
at 100% Cu

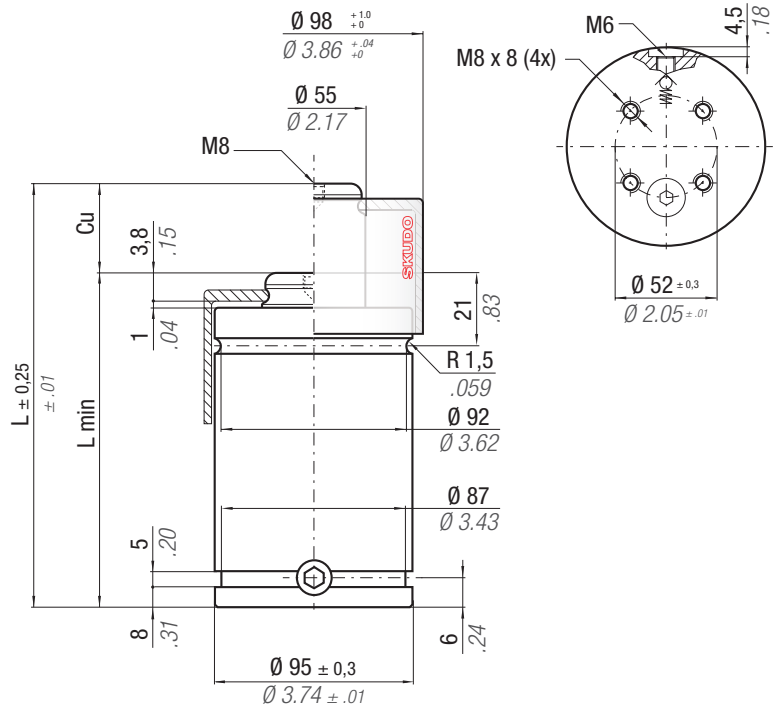

N₂	0 - 80 °C 32 - 176 °F	ΔP ± 0,33 %/°C	P max 150 bar 2175 psi	P min 20 bar 290 psi	S 50,27 cm ² 7.791 in ²	SPM ~ 80 - 100 (at 20°C)	Max Speed 0,8 m/s 31.5 in/s	Maintenance kit 39BMKE07500B
----------------------	--------------------------	--------------------------	-------------------------------------	-----------------------------------	------------------------------------------------------------	---------------------------------------	------------------------------------------	----------------------------------------

CODE	Cu		L		L min		F ₀		F _{1i} *		F _{1p} **		V ₀		~Kg		~lb		PED 2014/68/EU	
	mm	inch	mm	inch	mm	inch	daN	lb	daN	lb	daN	lb	cm ³	in ³						
KE 7500 - 010 - B	10	0.39	90	3.54	80	3.15	7540 16950 ± 5%		11818	26568	14332	32220	160	9.75	2,89	6.37	✓			
KE 7500 - 016 - B	16	0.63	116	4.57	100	3.94			11514	25885	13845	31125	269	16.40	3,26	7.19	✓			
KE 7500 - 025 - B	25	0.98	145	5.71	120	4.72			12127	27263	14833	33345	382	23.29	3,64	8.02	✓			
KE 7500 - 032 - B	32	1.26	182	7.17	150	5.91			150 bar 2175psi	11462	25767	13762	30938	542	33.08	4,18	9.22	✓		
KE 7500 - 040 - B	40	1.57	210	8.27	170	6.69			11676	26249	14104	31708	654	39.90	4,56	10.05	✓			
KE 7500 - 050 - B	50	1.97	255	10.04	205	8.07			+ 20 °C +68 °F	11486	25822	13801	31025	844	51.47	5,19	11.44	✓		
KE 7500 - 065 - B	65	2.56	279	10.98	214	8.43		12805	28786	15943	35840	910	55.51	5,46	12.40	✓				

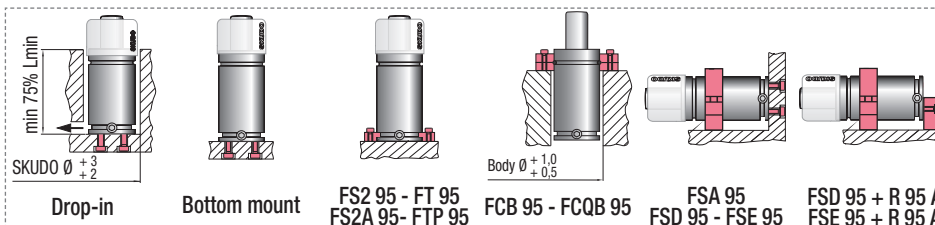
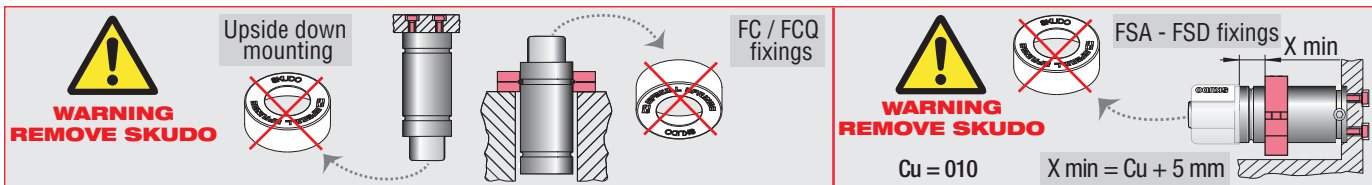

HOW TO ORDER
 p. 195

INSTALLATION GUIDELINE
 p. 205



SW

ACTIVE SAFETY



OSAS



USAS



OPAS



SKUDO

Il nuovo codice sarà fornito solo ad esaurimento del vecchio
 The new code will be supplied only when the old will be out of stock
 Der neue Kode wird nur angegeben, wenn der alte nicht mehr lieferbar ist
 Le nouveau code sera fourni uniquement lorsque le vieux stock sera écoulé
 El nuevo código será suministrado sólo cuando se agoten las existencias del antiguo
 O novo código irá ser fornecido apenas quando o antigo esgotar stock

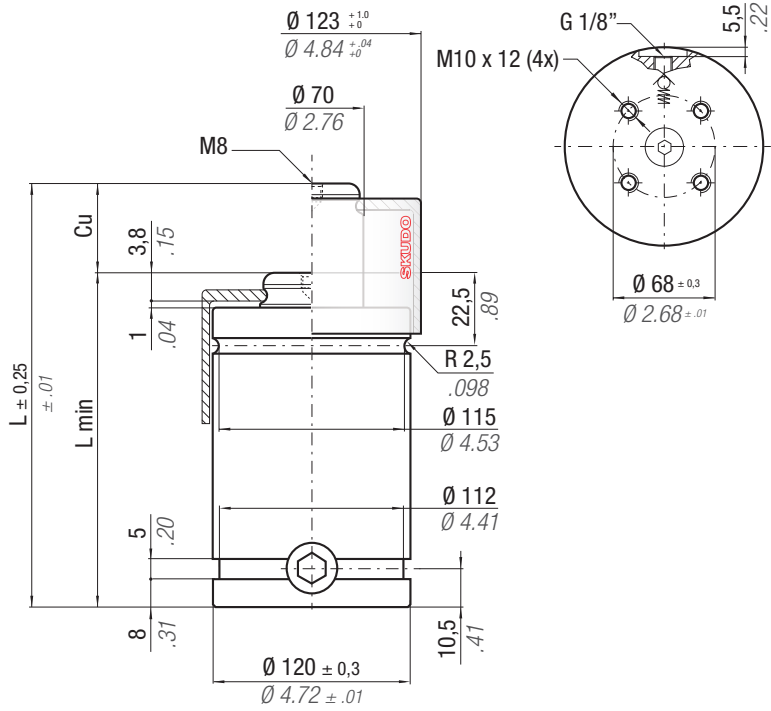

eASU MANIFOLDO p. 247

p. 262

* $F_{1i} =$

Isothermal end force p. 16 at 100% Cu

** $F_{1p} =$

Polytropic end force p. 16 at 100% Cu

CODE	Cu		L		L min		F ₀		F _{1i} *		F _{1p} **		V ₀		Maintenance kit		
	mm	inch	mm	inch	mm	inch	daN	lb	daN	lb	daN	lb	cm ³	in ³	~Kg	~lb	
KE 12000 - 010 - B	10	0.39	100	3.94	90	3.54	11780	26482	17843	40113	21398	48104	267	16.28	5,49	12.10	✓
KE 12000 - 016 - B	16	0.63	126	4.96	110	4.33			17646	39670	21084	47399	437	26.64	6,11	13.47	✓
KE 12000 - 025 - B	25	0.98	155	6.10	130	5.12	150 bar	2175psi	18657	41943	22704	51040	613	37.39	6,76	14.90	✓
KE 12000 - 032 - B	32	1.26	187	7.36	155	6.10			18166	40838	21913	49261	824	50.28	7,54	16.62	✓
KE 12000 - 040 - B	40	1.57	220	8.66	180	7.09	+ 20 °C	+ 68 °F	18098	40687	21805	49020	1037	63.30	8,31	18.32	✓
KE 12000 - 050 - B	50	1.97	260	10.24	210	8.27			18116	40727	21834	49084	1294	78.97	9,25	20.9	✓
KE 12000 - 065 - B	65	2.56	320	12.60	255	10.04	18133	40764	21860	49143	1679	102.48	10,66	23.50	✓		

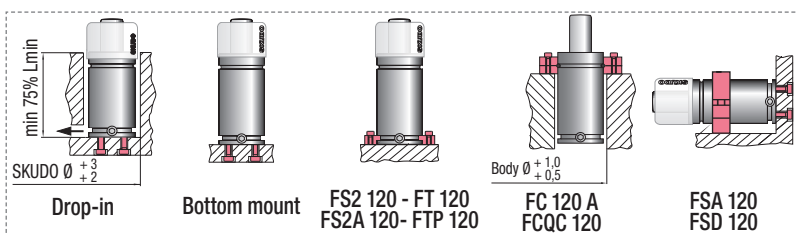
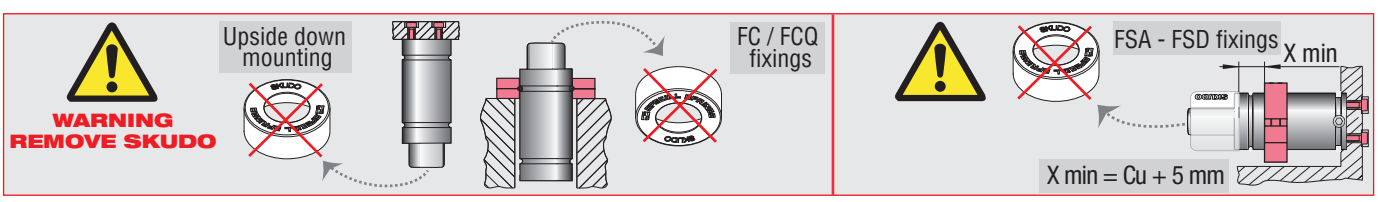

HOW TO ORDER

p. 195

INSTALLATION GUIDELINE

p. 205



SW

ACTIVE SAFETY



OSAS



USAS



OPAS



SKUDO

Il nuovo codice sarà fornito solo ad esaurimento del vecchio

The new code will be supplied only when the old will be out of stock

Der neue Kode wird nur angegeben, wenn der alte nicht mehr lieferbar ist

Le nouveau code sera fourni uniquement lorsque le vieux stock sera écoulé

El nuevo código será suministrado sólo cuando se agoten las existencias del antiguo

O novo código irá ser fornecido apenas quando o antigo esgotar stock

easu MANIFOLD p. 247

p. 262

* F_{1i} =
Isothermal
end force
at 100% Cu p. 16

** F_{1p} =
Polytrophic
end force
at 100% Cu

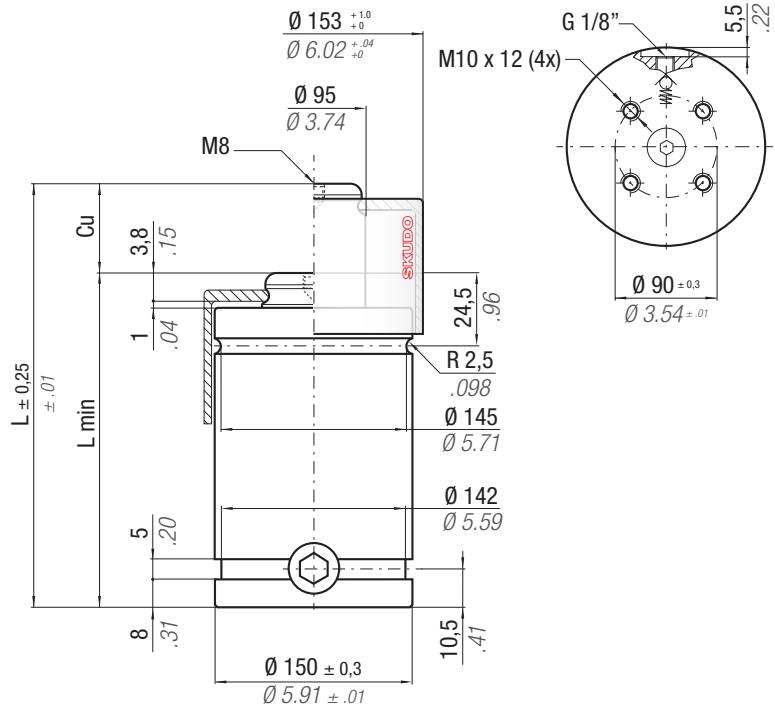

	0 - 80 °C 32 - 176 °F	ΔP ± 0,33 %/°C	P max 150 bar 2175 psi	P min 20 bar 290 psi	S 122,72 cm ² 19.022 in ²	SPM ~ 50 - 100 (at 20°C)	Max Speed 0,8 m/s 31.5 in/s	Maintenance kit 39BMKE18500B
--	--------------------------	---------------------------	-------------------------------------	-----------------------------------	--------------------------------------------------------------	---------------------------------------	------------------------------------------	----------------------------------------

CODE	Cu		L		L min		F ₀		F _{1i} *		F _{1p} **		V ₀		PED		
	mm	inch	mm	inch	mm	inch	daN	lb	daN	lb	daN	lb	cm ³	in ³	~Kg	~lb	2014/68/EU
KE 18500 - 010 - B	10	0.39	110	4.33	100	3.94	18410 41386 ± 5%	150 bar 2175psi	25880	58181	30288	68090	493	30.08	9,31	20.53	✓
KE 18500 - 016 - B	16	0.63	136	5.35	120	4.72			26201	58903	30788	69214	765	46.68	10,28	22.66	✓
KE 18500 - 025 - B	25	0.98	165	6.50	140	5.51			27771	62431	33260	74771	1050	64.08	11,30	24.91	✓
KE 18500 - 032 - B	32	1.26	197	7.76	165	6.50			27347	61479	32588	73261	1388	84.69	12,51	27.58	✓
KE 18500 - 040 - B	40	1.57	235	9.25	195	7.68			26947	60580	31957	71842	1791	109.31	13,93	30.71	✓
KE 18500 - 050 - B	50	1.97	270	10.63	220	8.66			27505	61833	32838	73823	2142	130.73	15,19	33.49	✓
KE 18500 - 065 - B	65	2.56	323	12.72	258	10.16	28055	63070	33713	75790	2675	163.23	17,10	37.70	✓		

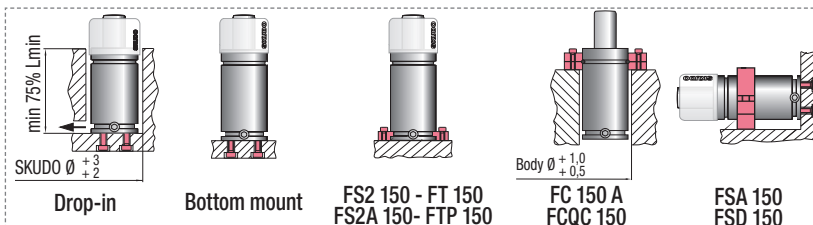
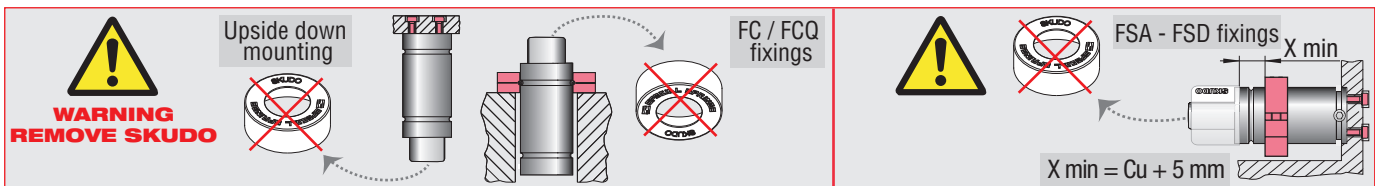

HOW TO ORDER

p. 195

INSTALLATION GUIDELINE

p. 205

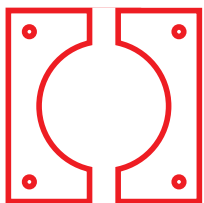

INSTALLATION GUIDELINE

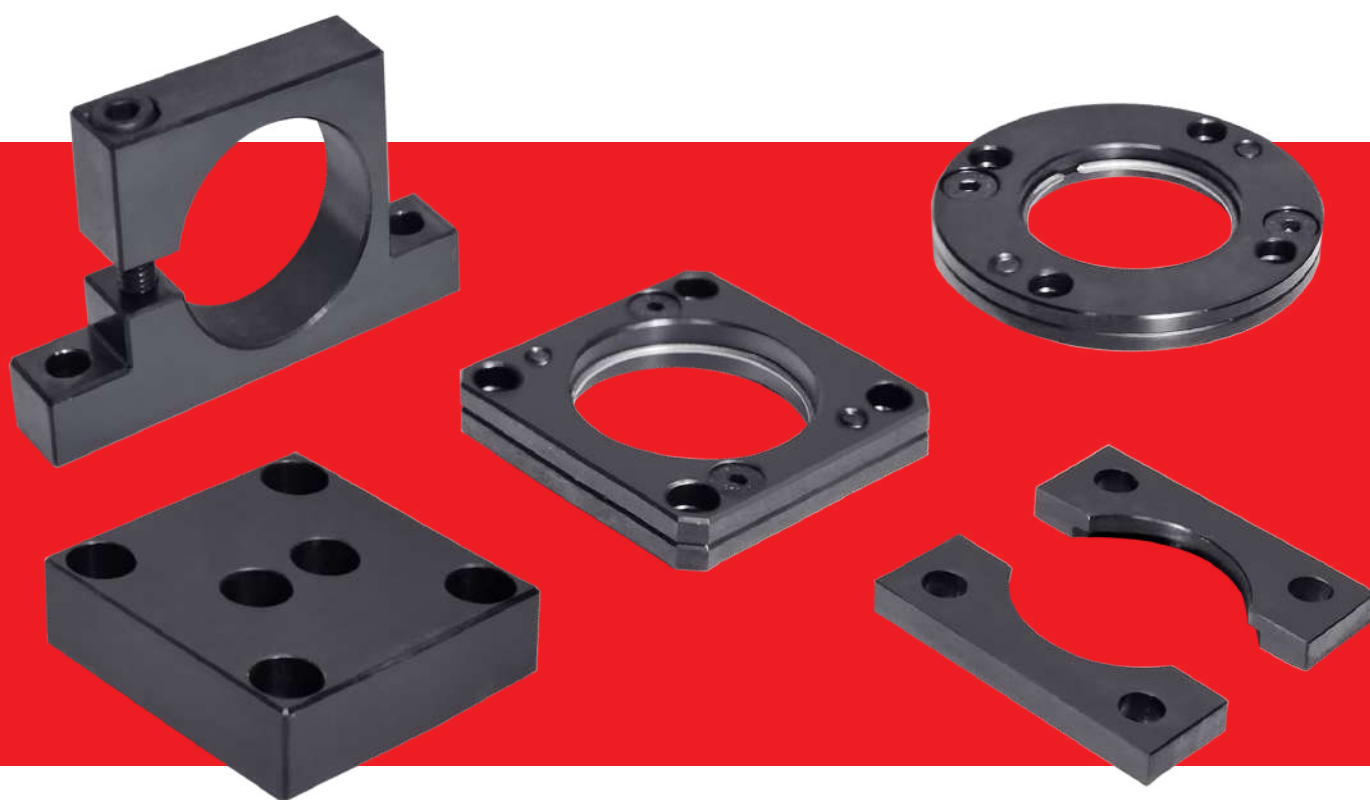

INSTALLATION GUIDELINE



- IT** Un corretto fissaggio dei cilindri ad azoto previene danni ai prodotti e gravi pericoli agli operatori.
- EN** A correct fixing of the gas springs prevents damages to products and serious dangers to operators.
- DE** Die richtige Befestigung der Gasdruckfeder verhindert Schäden an den Produkten und ernsthafte Gefahren für das Personal.
- FR** La fixation correcte du ressort à gaz évite des dommages aux produits et des dangers graves pour les opérateurs.
- ES** Una correcta fijación del cilindro de gas previene daños a los productos y graves peligros a los operadores.
- PT** Uma correta fixação do cilindro pode prevenir danos ao produto e também ao operador.

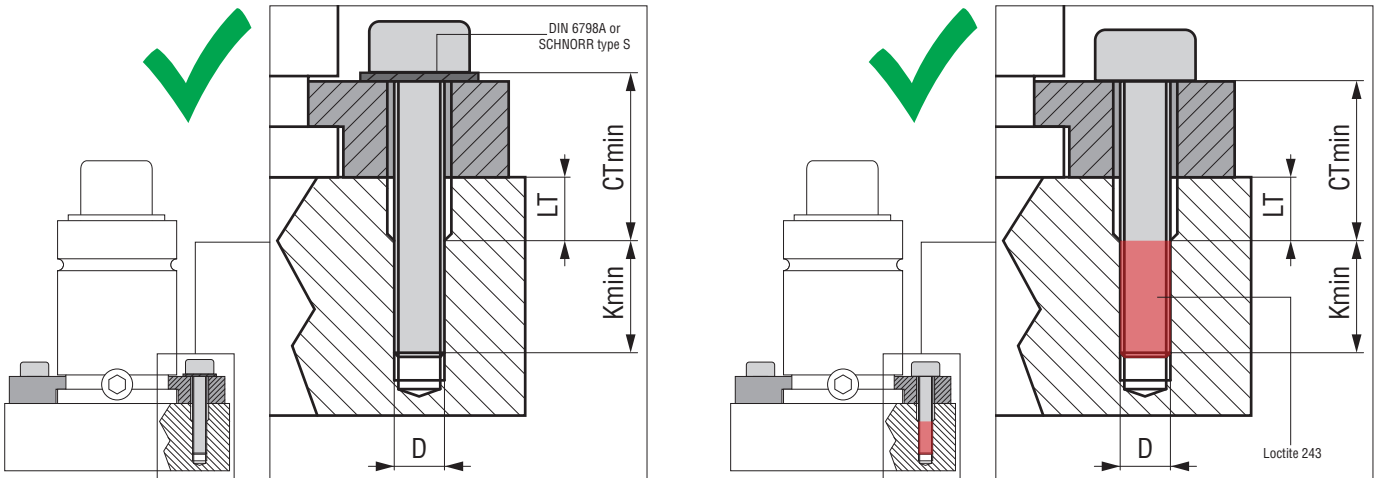

CTmin	Kmin	LT
Lunghezza libera (min. 2 x D)	Minimo impegno viti (acciaio = min. 1.5 x D, ghisa = min. 2 x D)	Allargamento per garantire CTmin
Free length (min. 2 x D)	Minimum thread engagement (steel = min. 1.5 x D, cast iron = min. 2 x D)	Widening to ensure CTmin
Klemmlänge (min. 2 x D)	Mindest-Einschraublänge (Stah = min. 1.5 x D, Guss = min. 2 x D)	Bohrung zur Gewährleistung der CTmin
Longueur libre (min. 2 x D)	Longueur minimum à visser (acier = min. 1.5 x D, fonte = min. 2 x D)	Élargissement pour assurer CTmin
Longitud libre (min. 2 x D)	Longitud mínima de roscado (acero = min. 1.5 x D, fundición = min. 2 x D)	Margen para garantizar CTmin
Comprimento livre (min. 2 x D)	Comprimento mínimo roscado (aço 1,5 x D – Fundido 2,0 x D)	Alívio para garantir o CT min

- IT** Utilizzare sempre apposito frenafiletti e/o rondelle di sicurezza su tutte le viti di fissaggio. (Non rappresentate nei disegni delle pagine seguenti).
- EN** Always use the suitable threadlocker and/or safety washers on all fixing screws. (They are not represented in the drawings in the following pages of the catalog).
- DE** Verwenden Sie immer geeignete Schraubensicherungen und/oder Sicherungsscheiben an allen Befestigungsschrauben. (Nicht in den Zeichnungen auf den folgenden Seiten dargestellt).
- FR** Utilisez toujours le frein filet approprié et/ou les rondelles de sécurité sur toutes les vis de fixation. (Ils ne sont pas représentés sur les dessins dans les pages suivantes du catalogue).
- ES** Utilice siempre un adhesivo fijador de roscas adecuado y/o arandelas de seguridad en todos los tornillos de fijación. (No están representados en los dibujos de las páginas siguientes).
- PT** Sempre utilizar o trava roscas e/ou arruela de segurança em todos os parafusos de fixação (não estão representados nas próximas páginas do catalogo).



Rondelle di sicurezza - Safety Washers
Sicherungsscheiben - Rondelles de sécurité
Arandelas de seguridad - Arruela de segurança

Only for ML, MP,
MQ series



Conical spring
washer provided
by Special Springs



DIN 6798A
or
SCHNORR type S

- IT** L'uso di viti di classe superiore alla 8.8, come 9.8, 10.9 e 12.9, è sempre possibile. Si raccomanda di NON SUPERARE i valori della coppia di serraggio indicati per la classe 8.8 per qualsiasi classe di viti utilizzata (vedi pag. 209).
- EN** It is always possible to use screws belonging to Classes higher than 8.8, such as 9.8, 10.9 and 12.9. Do NOT EXCEED the values of the tightening torque valid for Class 8.8 for any of the screw's Classes you may use (see page 209).
- DE** Die Verwendung von Schrauben von höheren Klassen als 8.8, wie 9.8, 10.9 und 12.9 ist immer möglich. Es wird empfohlen, die für die Klasse 8.8 angegebenen Anziehdrehmomente für alle verwendeten Schraubenklassen nicht zu überschreiten (voir page 209).
- FR** L' est toujours possible d'utiliser des vis appartenant aux classes supérieures à 8.8, telles que 9.8, 10.9 et 12.9. NE PAS DÉPASSER les valeurs du couple de serrage indiquées pour la classe 8.8 pour n'importe quelle classe de résistance que vous allez utiliser (voir page 209).
- ES** El uso de tornillos de calidad superior a 8.8, como 9.8, 10.9 y 12.9 está permitido. Se recomienda NO EXCEDER el par de apriete indicado para la clase 8.8 para cualquier calidad de tornillos utilizados (consulte la página 209).
- PT** Sempre é possível usar parafusos pertencentes a classes superiores a 8.8, como 9.8, 10.9 e 12.9. NÃO SUPERAR os valores do torque recomendado para os parafusos da classe 8.8, mesmo que esteja utilizando parafusos com classes diferentes, (ver página 209).

- IT** Cilindro ad azoto con fori di fissaggio in cui il valore di A è maggiore del valore D (esempio SC3000 con fori di fissaggio M8x13).
- EN** Gas spring with fixing holes for which value A is bigger than value D (e.g. SC3000 with fixing holes M8x13).
- DE** Gasdruckfeder mit Befestigungsbohrungen bei denen der Wert A größer als der Wert D ist (Beispiel SC3000 mit Befestigungsbohrungen M8x13).
- FR** Ressort à gaz avec trous de fixation dans lequel la valeur A est supérieure à la valeur D (par exemple, SC3000 avec trous de fixation M8x13).
- ES** Cilindro de gas con agujeros de fijación en el que el valor A es mayor que el valor D (ejemplo SC3000 con agujeros de fijación M8x13).
- PT** Cilindros com furos de fixação que a medida A é maior que a medida D (ex. SC3000 com furos de fixação M8x13).

Installation Example: $A > D$

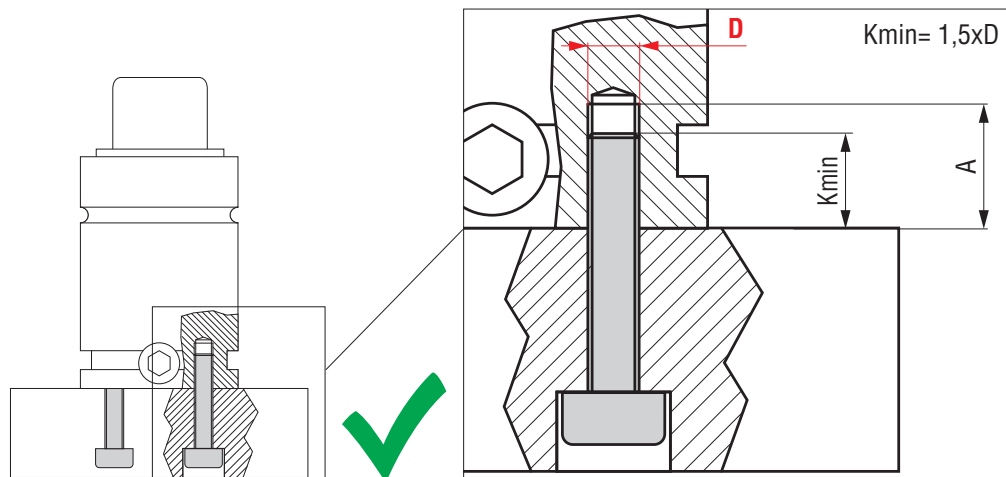

- IT** Cilindro ad azoto in cui il valore A è minore del valore D (esempio RV1000 con fori di fissaggio M8x6). Attenzione: in questi casi utilizzare viti con lunghezza tale da impegnare l'intera profondità utile di fissaggio.
- EN** Gas spring with fixing holes for which value A is smaller than value D (e.g. RV1000 with fixing holes M8x6). In such cases, be careful to use screws with a length long enough to employ the whole usable fixing depth.
- DE** Gasdruckfeder bei der der Wert A kleiner als der Wert D ist (Beispiel RV1000 mit Befestigungsbohrungen M8x6). Achtung: Verwenden Sie in diesen Fällen Schrauben mit einer Länge, die über die gesamte Einschraublänge reicht.
- FR** Ressort à gaz avec trous de fixation dans lequel la valeur A est inférieure à la valeur D (par exemple, RV1000 avec trous de fixation M8x6). Dans ce cas, veuillez utiliser des vis suffisamment longues pour utiliser toute la profondeur de fixation utilisable.
- ES** Cilindro de gas en el que el valor A es menor que el valor D (ejemplo RV1000 con agujeros de fijación M8x6). Atención: en estos casos utilizar tornillos con una longitud que permita utilizar toda la profundidad útil de fijación.
- PT** Cilindros que a medida A é menor que a medida D (ex. RV1000 com furos de fixação M8x6). Neste caso, atentar para que o comprimento do parafuso seja suficiente para garantir o comprimento mínimo de roscado na placa.

Installation Example: $A \leq D$

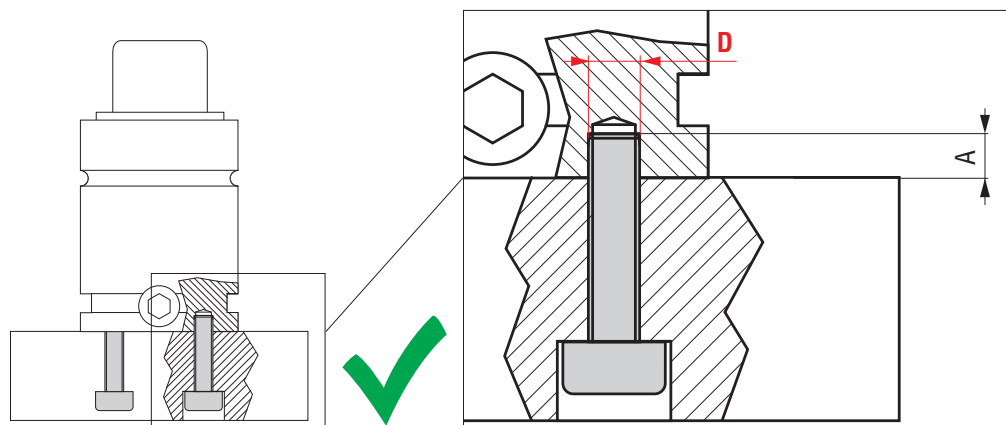

INSTALLATION GUIDELINE

IT Le viti di fissaggio non devono mai essere sollecitate direttamente dal carico agente sul cilindro ad azoto.

EN Fixing screws shall never be directly strained by the load acting on the gas spring.

DE Die Befestigungsschrauben dürfen niemals direkt durch die auf die Gasdruckfeder wirkende Last belastet werden.



FR Les vis de fixation ne doivent jamais être directement sollicitées par la charge agissant sur le ressort à gaz.

ES Los tornillos de fijación nunca deben recibir directamente la carga que se aplica sobre el cilindro de gas.

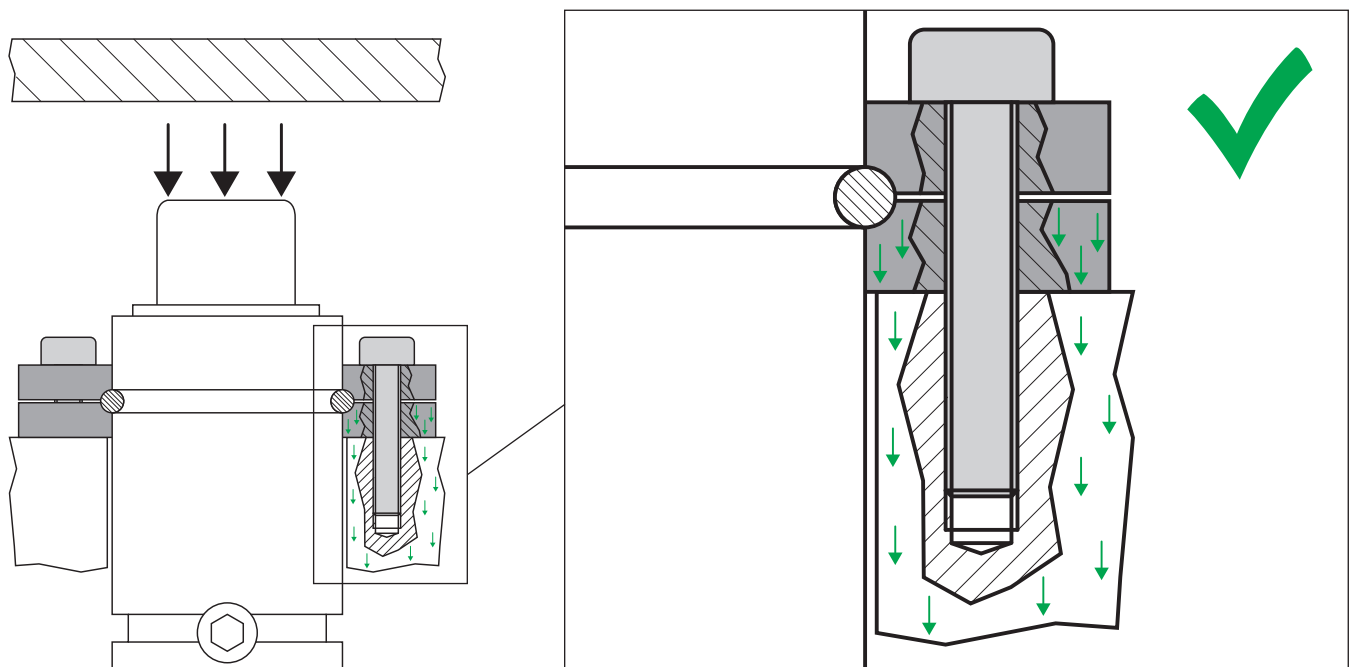
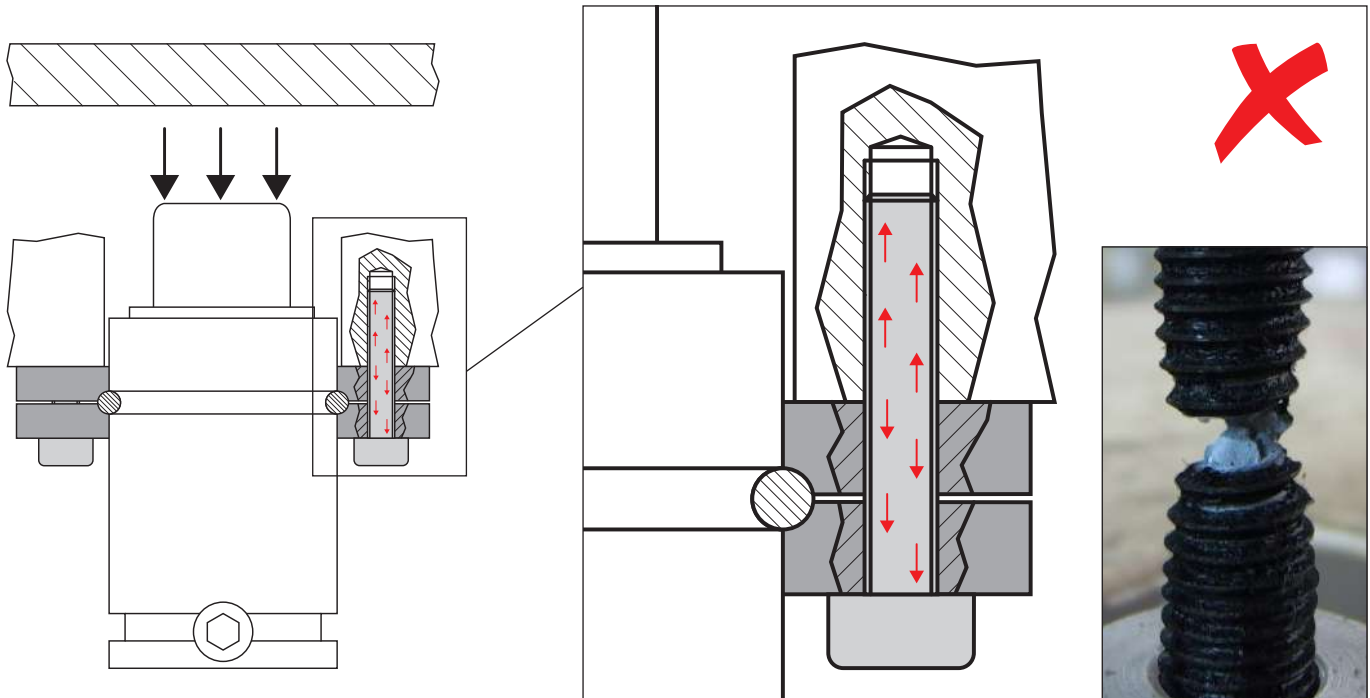
PT Os parafusos de fixação jamais devem receber diretamente a carga do cilindro.



- IT** Rispettare le coppie di serraggio prescritte e verificare sempre lo stato dei cilindri ad azoto e dei fissaggi ad ogni intervento sullo stampo.
- EN** Respect the specified tightening torques and verify always the condition of gas springs and fixings at each intervention on the die.
- DE** Beachten Sie die vorgeschriebenen Anziehdrehmomente und überprüfen Sie bei jedem Eingriff am Werkzeug den Zustand der Gasdruckfedern und Befestigungen.
- FR** Respectez les couples de serrage spécifiés et vérifiez les conditions des ressorts à gaz et des fixations à chaque intervention sur le moule.
- ES** Respete los pares de apriete indicados y verifique el estado de los cilindros de gas y de las fijaciones en cada intervención en el troquel.
- PT** Respeitar o torque dos parafusos especificado e a cada parada para manutenção da ferramenta deve ser verificado as condições dos cilindros e das flanges.

	ISO 4762 class 8.8	M5	M6	M8	M10	M12	M 16
	Torque force	6 Nm	10 Nm	24 Nm	50 Nm	84 Nm	205 Nm

- IT** Serrare tutte le viti di fissaggio seguendo l'ordine a croce (1, 2, 3, 4) applicando la coppia di serraggio corretta. In questo modo il cilindro ad azoto sarà perfettamente posizionato.
- EN** Tighten all fixing screws by following the order shown in the image (1, 2, 3, 4) and by applying the correct tightening torque. In doing so, the gas springs will be perfectly positioned.
- DE** Alle Befestigungsschrauben über Kreuz in der Reihenfolge 1, 2, 3, 4 (s. Bild) mit dem richtigen Anziehdrehmoment anziehen. Auf diese Weise wird die Gasdruckfeder perfekt positioniert.
- FR** Serrez toutes les vis de fixation en respectant l'ordre indiqué sur l'image (1, 2, 3, 4) et en appliquant le couple de serrage approprié. Ce faisant, les ressorts à gaz seront parfaitement positionnés.
- ES** Apriete todos los tornillos de fijación siguiendo el orden que se muestra en la imagen (1, 2, 3, 4) y aplicando el par de apriete correcto. Al hacerlo, los resortes de gas estarán perfectamente posicionados.
- PT** Os parafusos devem ser apertados seguindo a ordem do desenho (1,2,3,4) e aplicado o torque correto. Dessa forma os cilindros estarão perfeitamente fixados.

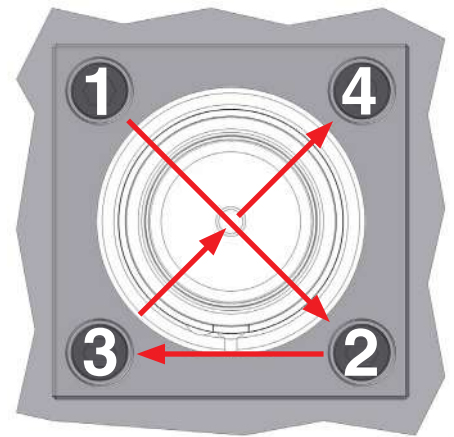
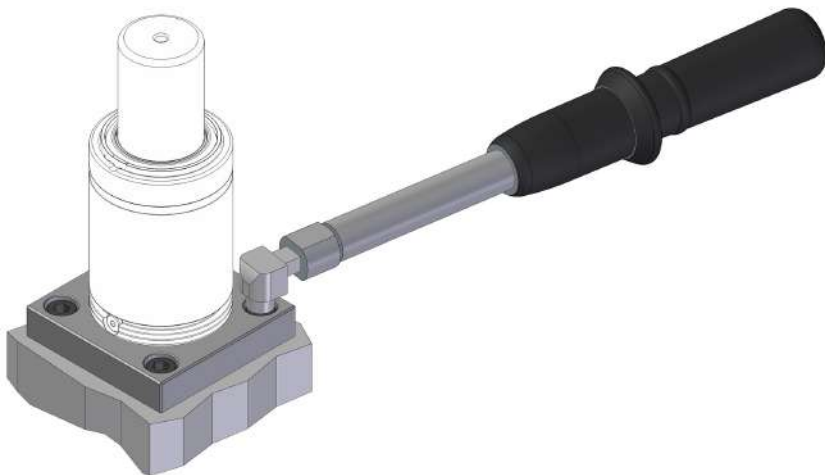

- IT** I cilindri ad azoto devono essere sempre installati perpendicolarmente rispetto alla direzione di trasmissione della forza.
- EN** Gas springs must always be installed perpendicular to the direction of force transmission.
- DE** Die Gasdruckfedern müssen immer lotrecht hinsichtlich der Richtung der Kraftübertragung eingebaut werden.
- FR** Les ressorts à gaz doivent toujours être installés perpendiculairement à la direction de la transmission de la force.
- ES** Los cilindros de gas siempre deben ser instalados perpendicularmente respecto a la dirección de transmisión de la fuerza.
- PT** Os Cilindros de Nitrogenio devem sempre ser instalados perpendicular a direção da força de acionamento.

- IT** I fori di alloggiamento in cui vengono installati i cilindri ad azoto devono sempre essere provvisti di fori di drenaggio.
- EN** The housing holes where the gas springs are installed must always have drain holes.
- DE** Die Gehäusebohrungen, in den die Gasdruckfedern eingebaut werden, müssen immer ein Drainage Loch haben.
- FR** Les logements de l'outil où sont installés les vérins à gaz doivent toujours avoir des trous de drainage.
- ES** Los agujeros en los que se instalan los cilindros siempre deben tener agujeros de drenaje.
- PT** Os alojamentos dos cilindros devem sempre ter um furo para drenagem.

Esempi di installazione - Installation examples - Montagebeispiele - Exemples d'installation - Ejemplos de instalación - Exemplo de instalação

DROP - IN

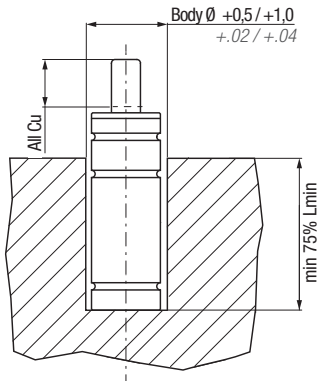

Installation in a flat-end hole.

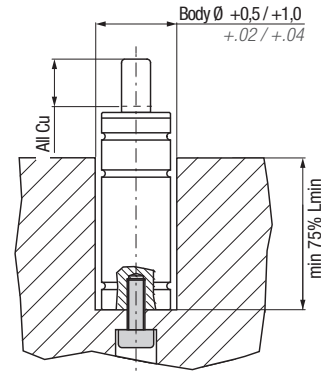

Installation in a flat-end hole with bottom fixing screws.

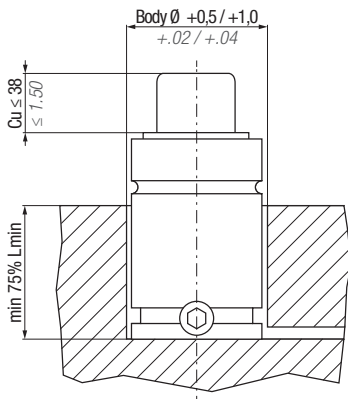

Installation in a flat-end hole.

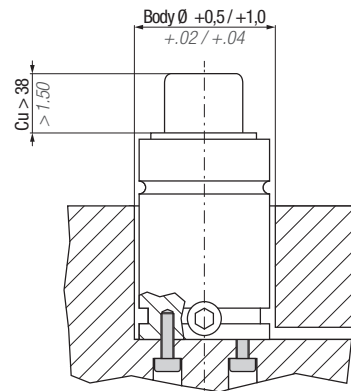

Installation in a flat-end hole with bottom fixing screws.

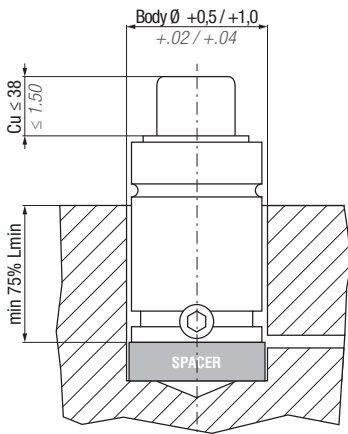

Installation in a flat-end hole with spacer.

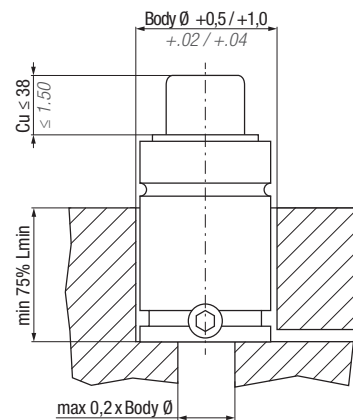

Max throughout bottom hole dimension for drop-in installation.

Esempi di installazione - Installation examples - Montagebeispiele - Exemples d'installation - Ejemplos de instalación - Exemplo de instalação

DROP - IN (ML, MP, MQ p. 221 - 222)

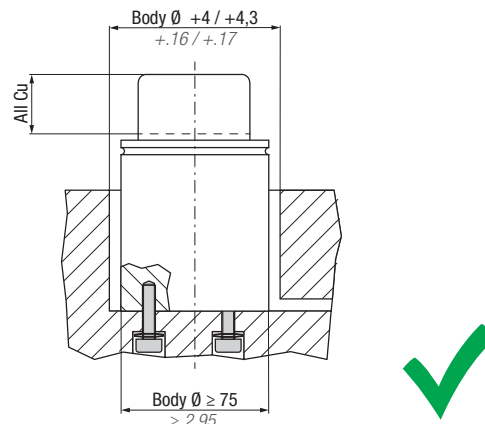
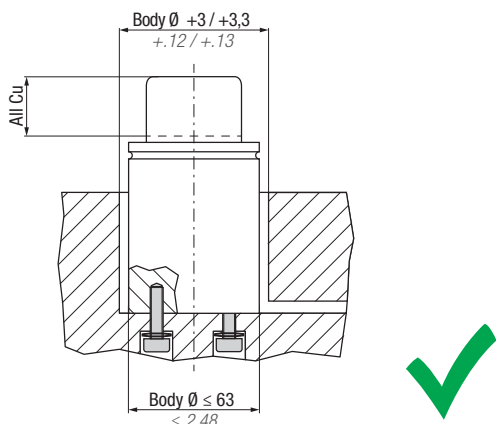

Installation in a flat-end hole with bottom fixing screws.

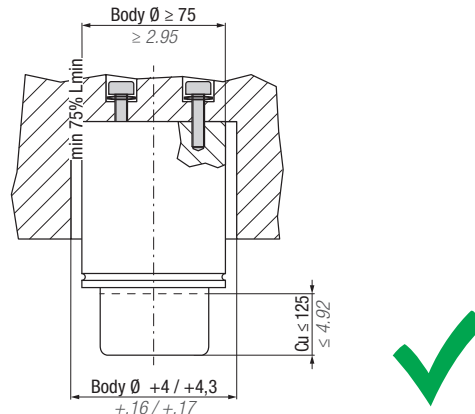
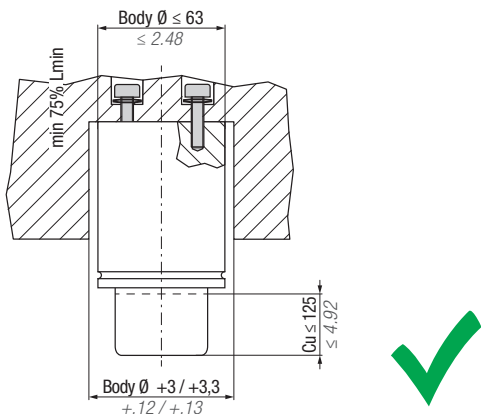

Installation in a flat-end hole with fixing screws in upside down position.

DROP - IN

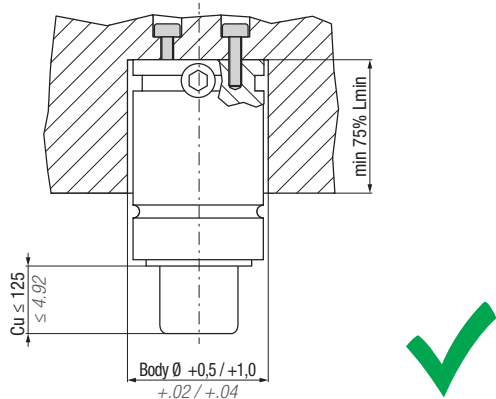

Installation in a flat-end hole with fixing screws in upside down position.

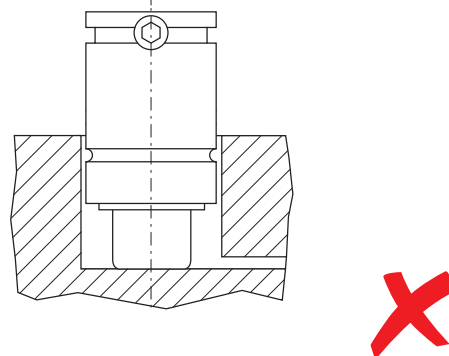

Installation NOT allowed due to excessive body wearing.

Esempi di installazione - Installation examples - Montagebeispiele - Exemples d'installation - Ejemplos de instalación - Exemplo de instalação

BODY THREADED HOLES

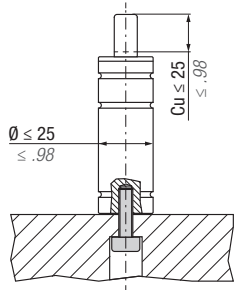

Installation with single fixing screw.

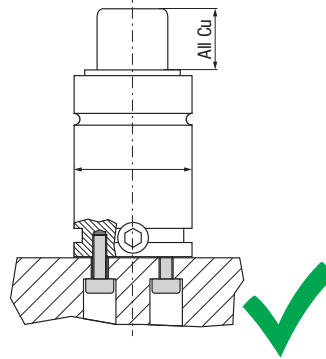

Installation with bottom fixing screws.

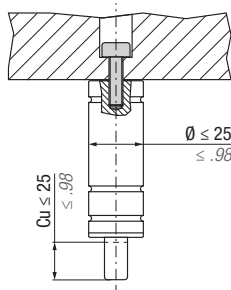
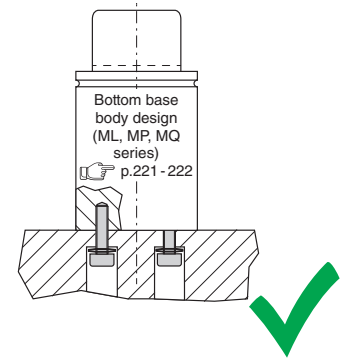

Installation with single fixing screw in upside down position.

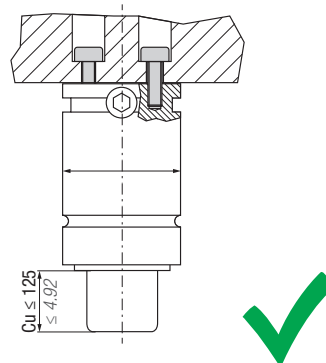

Installation with bottom fixing screws in upside down position.

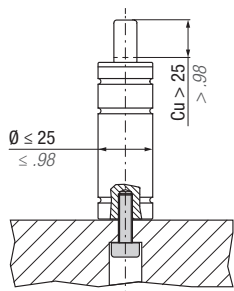
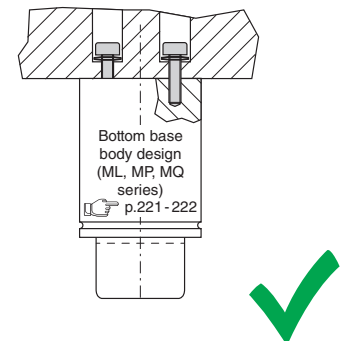

Installation NOT allowed due to excessive stress on gas spring bottom.

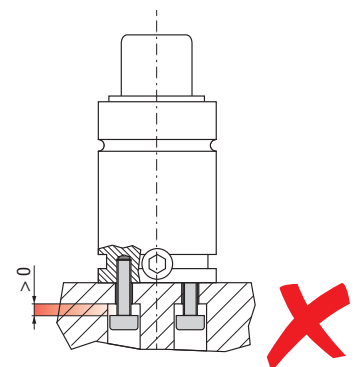
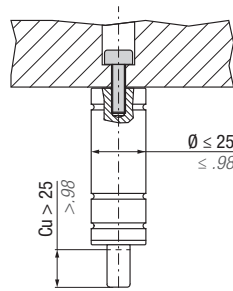

Installation NOT allowed due to incorrect screw length.

Esempi di installazione - Installation examples - Montagebeispiele - Exemples d'installation - Ejemplos de instalación - Exemplo de instalação

FB - FBA - FBB - FBC - FBD - FBF

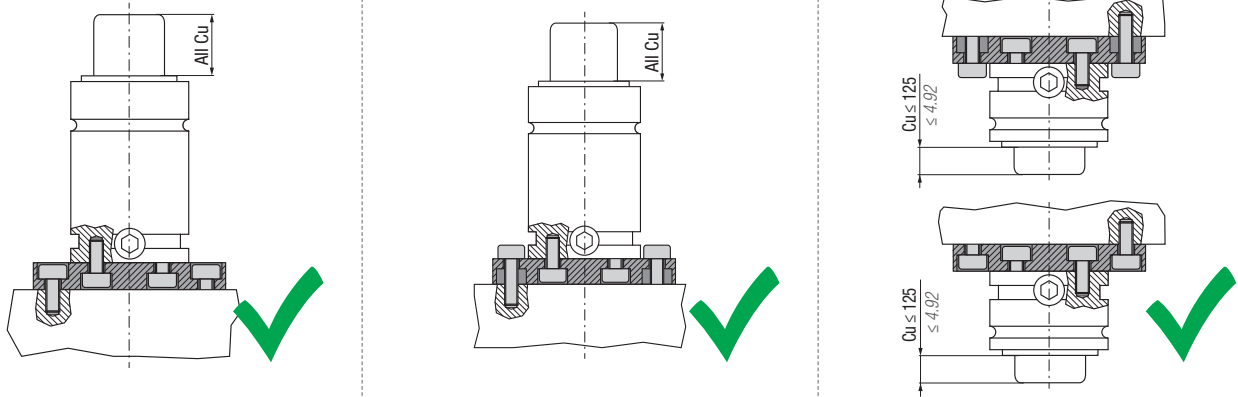

Installation with base flange through fixing screws.

FBE

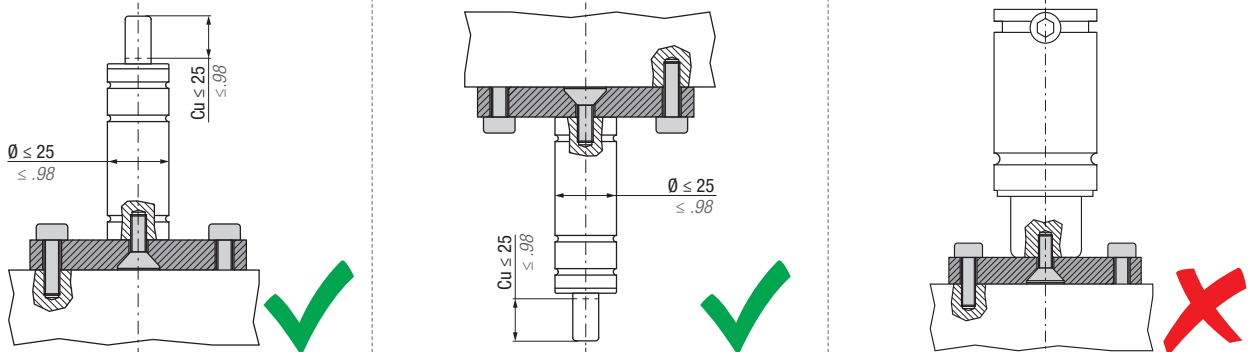

Installation with base flange through single fixing screw.

Installation with base flange through single fixing screw in upside down position.

Installation NOT allowed due to excessive stress on screw and internal components.

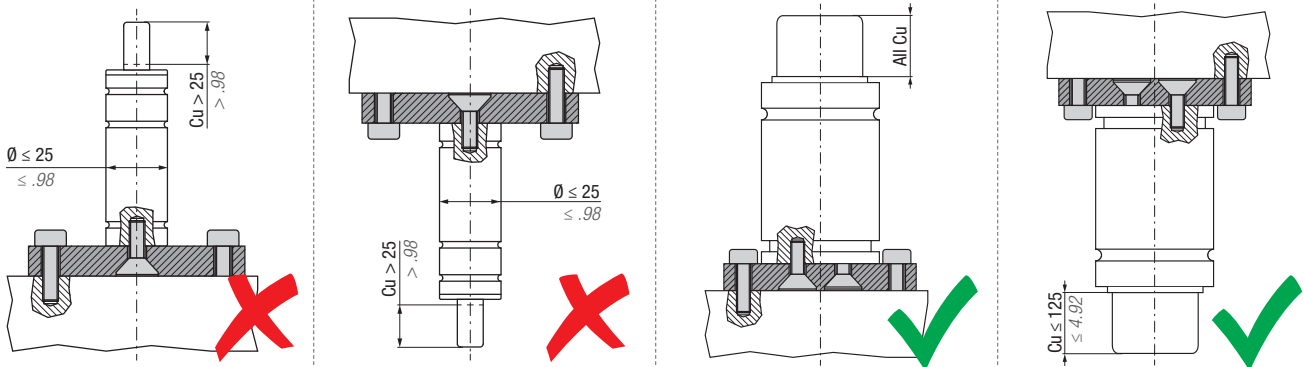

Installation NOT allowed due to excessive stress on gas spring bottom.

Installation with base flange through fixing screws.

Installation with base flange through fixing screws in upside down position.

All dimensions in mm /inch

INSTALLATION GUIDELINE - TOP MOUNT



Esempi di installazione - Installation examples - Montagebeispiele - Exemples d'installation - Ejemplos de instalación - Exemplo de instalação

FCB - FCD - FC - FCC - FCQ - FCQC - FCQB

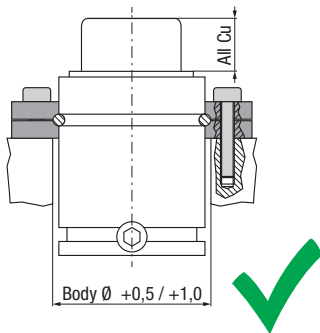

Installation with collar mount flange.

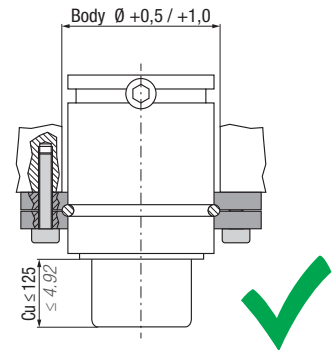
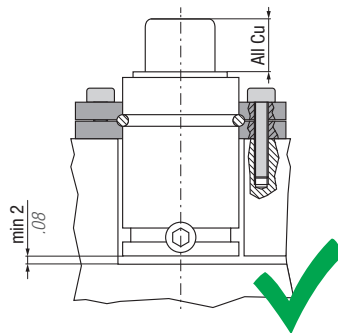

Installation with collar mount flange in upside down position.

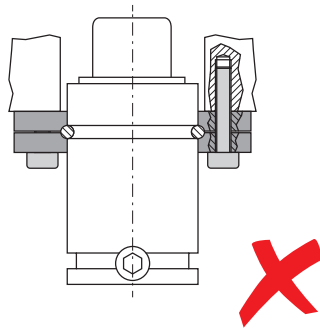

Installation NOT allowed due to tensile stress on screws.

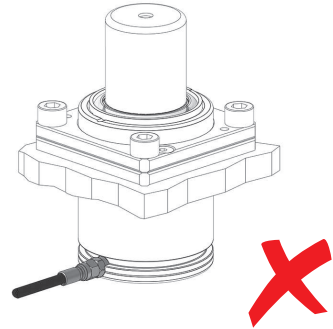
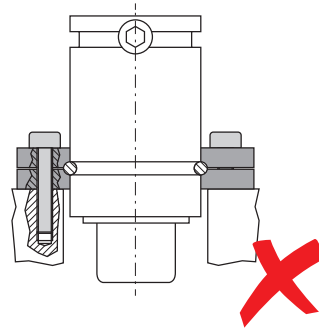

Installation NOT allowed due to risk of gas spring rotation and hose damage.

FC (for body gas spring Ø 12 ÷ 25)

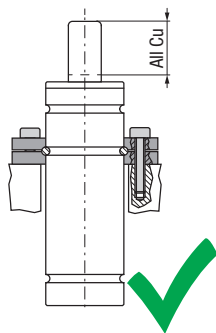

Installation with collar mount flange.

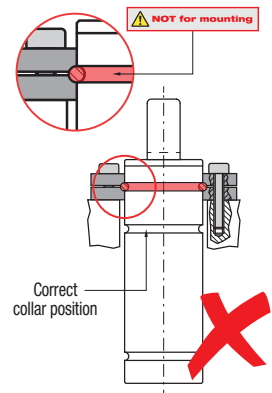
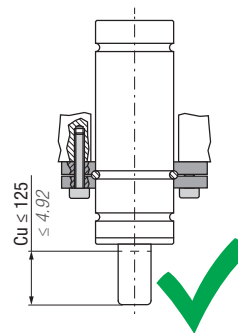
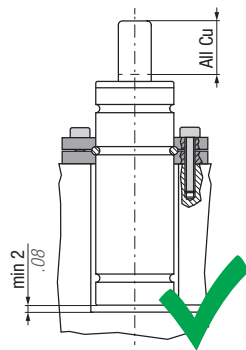

Installation NOT allowed due to excessive stress on internal component (wrong groove).

Esempi di installazione - Installation examples - Montagebeispiele - Exemples d'installation - Ejemplos de instalación - Exemplo de instalação

FS2 - FS2B - FS2A - FS2C

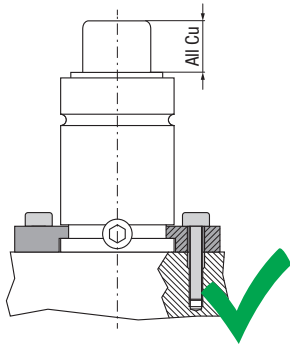

Installation with bracket mount flange.

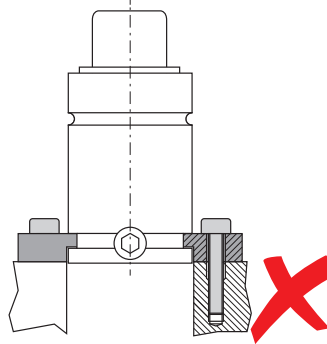

Installation NOT allowed due to excessive stress on gas spring body and flange.

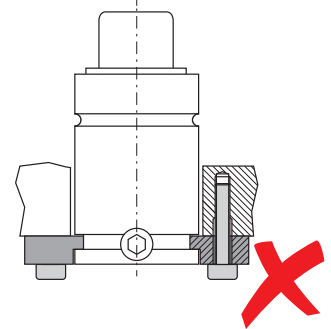

Installation NOT allowed due to tensile stress on screws.

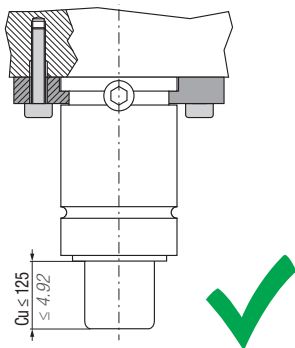

Installation with bracket mount flange in upside down position.

FS1

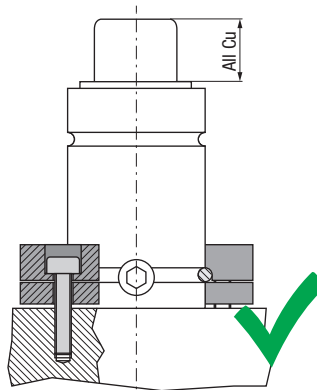

Installation with bracket mount flange.

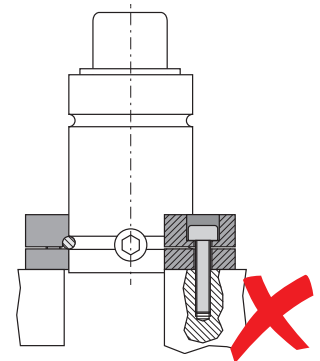

Installation NOT allowed due to excessive stress on gas spring body and flange.

FS3

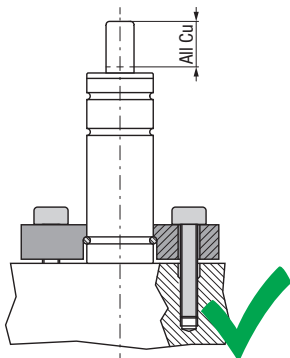

Installation with bracket mount flange.

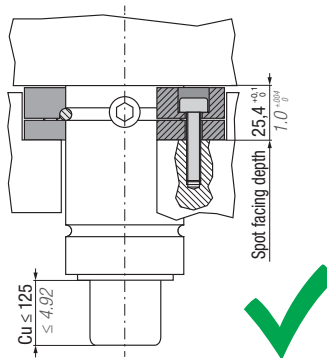

Installation with bracket mount flange in upside down position. Gas spring base must be in contact with upper plate.

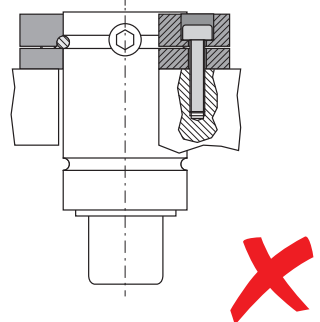

Installation NOT allowed due to tensile stress on screws.

All dimensions in mm /inch

INSTALLATION GUIDELINE - BRACKET MOUNT



Esempi di installazione - Installation examples - Montagebeispiele - Exemples d'installation - Ejemplos de instalación - Exemplo de instalação

FC (for body gas spring $\varnothing 12 \div 25$)

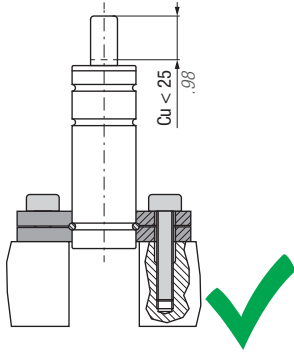

Installation with collar flange on the lower body groove.

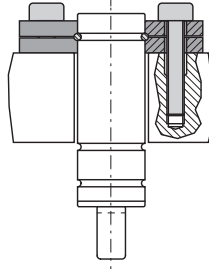

Installation NOT allowed due to tensile stress on screws.

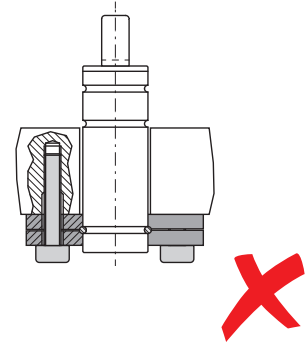

FT

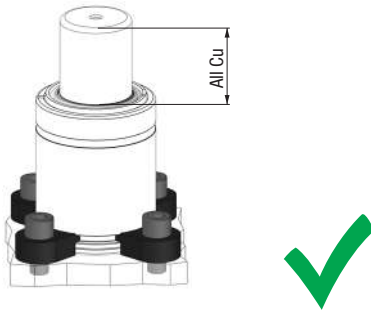

Installation with tooth flange on the lower body groove.

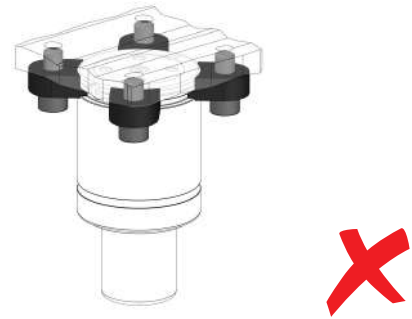

Installation NOT allowed due to risk of die damage in case of screw untightening.

FTP

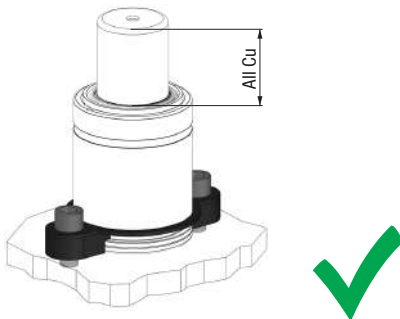

Installation with tooth flange on the lower body groove.

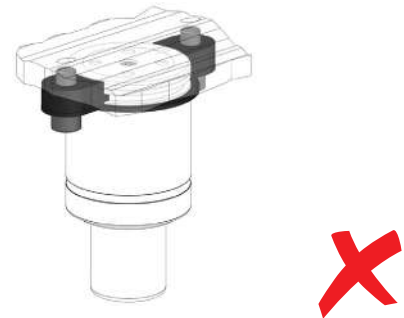

Installation NOT allowed due to risk of die damage in case of screw untightening.

Esempi di installazione - Installation examples - Montagebeispiele - Exemples d'installation - Ejemplos de instalación - Exemplo de instalação

FSA - FSB - FSC - FSD - FSE

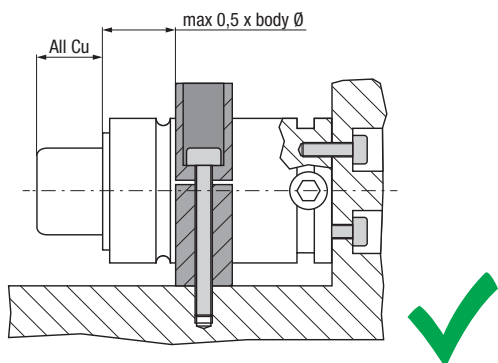

Installation with body mount flange and fixing screws.

(FSA - FSB - FSC - FSD - FSE) + R

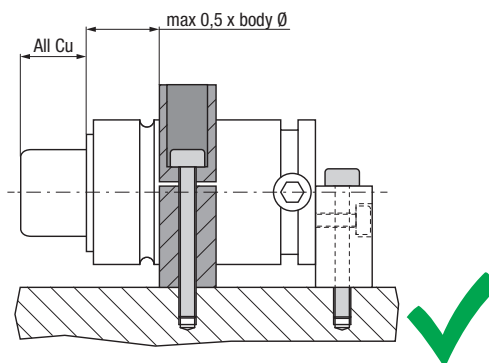

Installation with body mount flange and fixing screws in the rear support.

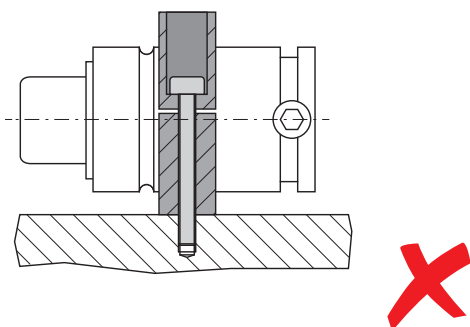

Installation NOT allowed due to lack of reaction force element.

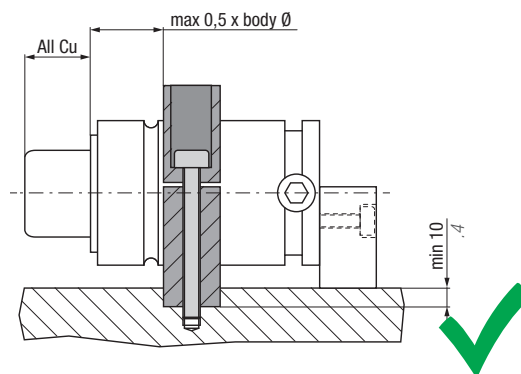

Installation with body mount flange and fixing screws in the rear support.

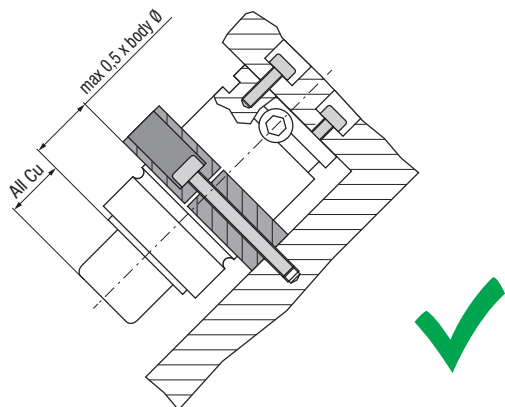

Installation with body mount flange and fixing screws.

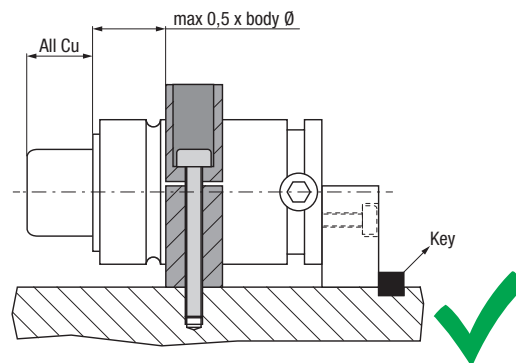

Installation with body mount flange and fixing screws in the key-fixed rear support.

INSTALLATION GUIDELINE - THREAD MOUNT



Esempi di installazione - Installation examples - Montagebeispiele - Exemples d'installation - Ejemplos de instalación - Exemplo de instalação

GM

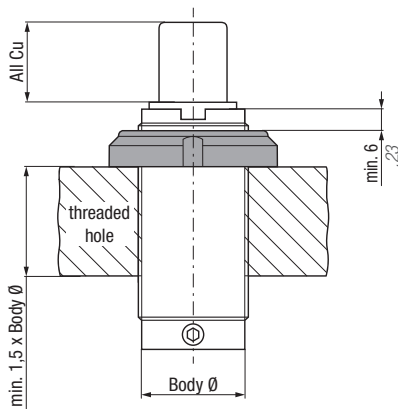

Installation into a threaded hole, locked by a threaded ring.

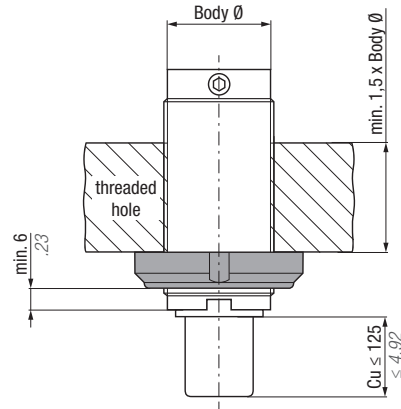

Installation into a threaded hole, locked by a threaded ring in upside down position.

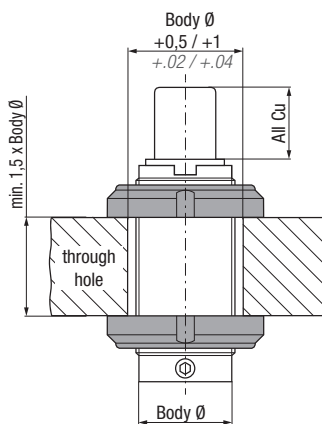

Installation into a through hole, locked by two threaded rings.

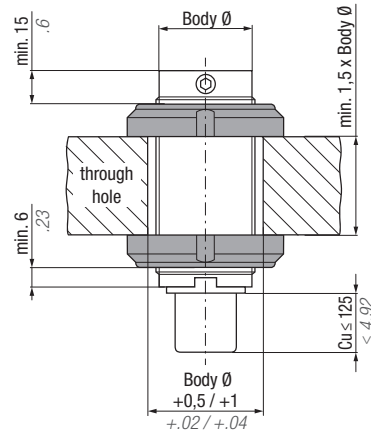

Installation into a through hole, locked by two threaded rings in upside down position.

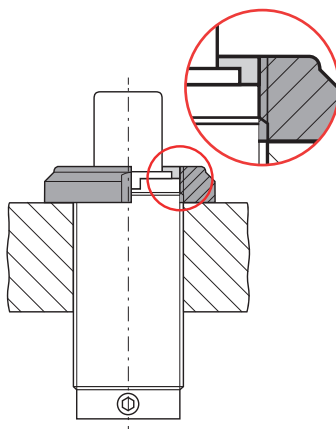

Installation NOT allowed due to insufficient length of engaged thread.

DM - DI

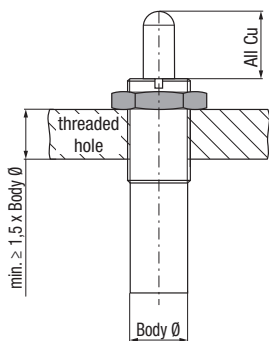

Installation into a threaded hole, locked by a nut.

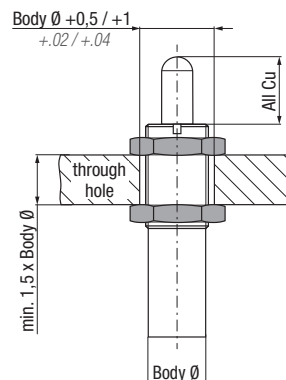

Installation into a through hole, locked by two nuts.

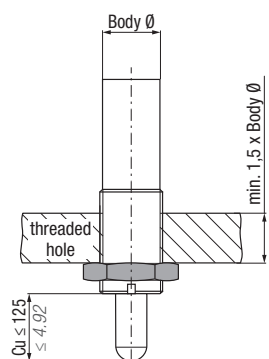

Installation into a threaded hole, locked by a nut in upside down position.

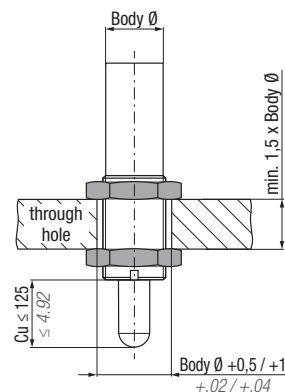

Installation into a through hole, locked by two nuts in upside down position.



INSTALLATION GUIDELINE - THREAD MOUNT



Esempi di installazione - Installation examples - Montagebeispiele - Exemples d'installation - Ejemplos de instalación - Exemplo de instalação

FCA

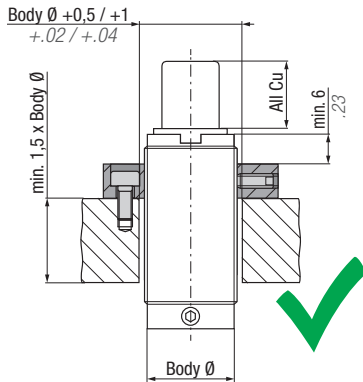

Installation into a through hole, fixed by a top mount threaded flange.

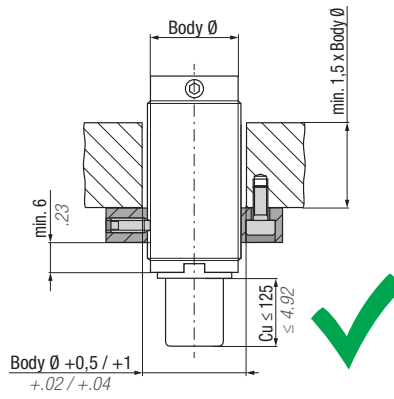

Installation into a through hole, fixed by a top mount threaded flange in upside down position.

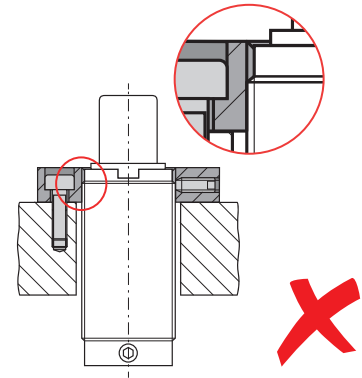

Installation NOT allowed due to insufficient engaged thread strength.

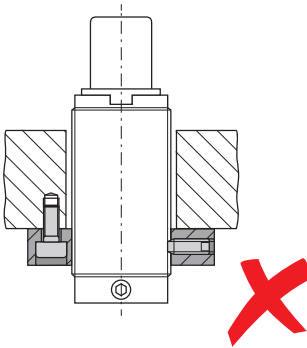

Installation NOT allowed due to tensile stress on screws.

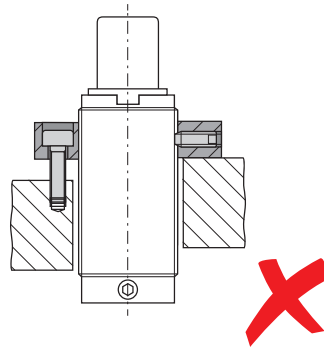

Installation NOT allowed due to off-axis positioning.

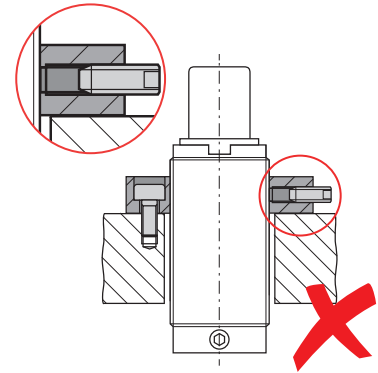

Installation NOT allowed due to gas spring untightening.

Esempi di installazione - Installation examples - Montagebeispiele - Exemples d'installation - Ejemplos de instalación - Exemplo de instalação

- IT** Installare i cilindri ad azoto rispettando le indicazioni fornite qui sotto. Informazioni dettagliate sono presenti nel kit dedicato.
- EN** Install the gas springs following the directions given here below. Detailed information is included in the specific kit.
- DE** Montieren Sie die Gasdruckfedern gemäß den unten folgenden Anweisungen. Detaillierte Anweisungen finden Sie im jeweiligen Bausatz.
- FR** Installez les ressorts à gaz en suivant les instructions données ci-dessous. Des informations détaillées sont incluses dans le kit spécifique.
- ES** Instale los cilindros de gas siguiendo las instrucciones facilitadas a continuación. Información detallada incluida en el kit correspondiente.
- PT** Fixar os cilindros respeitando as orientações abaixo. Todas as informações detalhadas estão presentes no manual de instruções de cada cilindro.

ML, MP, MQ series - SELF CONTAINED

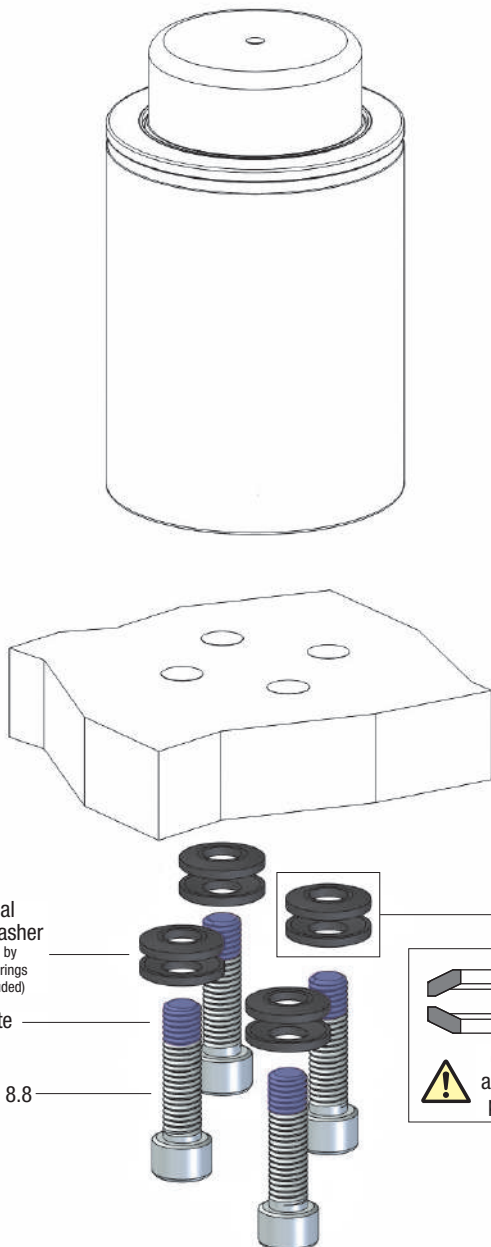

ML - LINKABLE

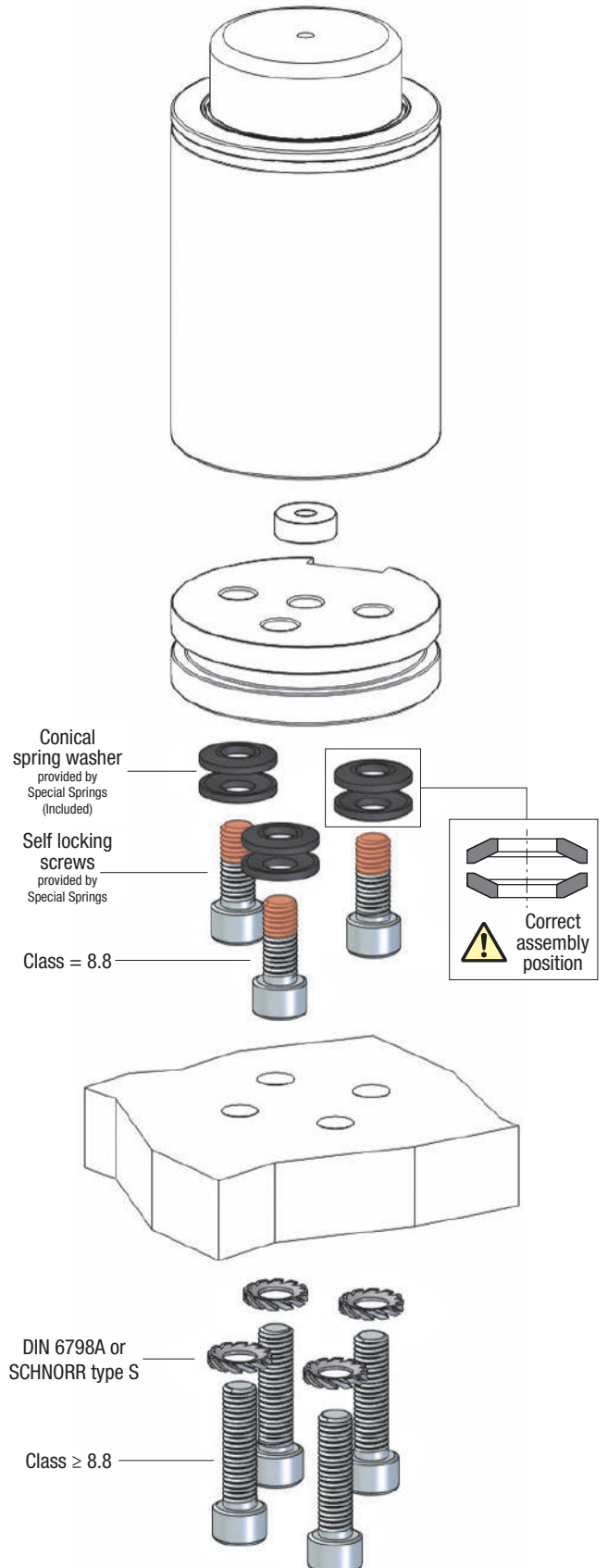

INSTALLATION GUIDELINE - ML, MP, MQ series



Esempi di installazione - Installation examples - Montagebeispiele - Exemples d'installation - Ejemplos de instalación - Exemplo de instalação

ML - EASY MANIFOLD

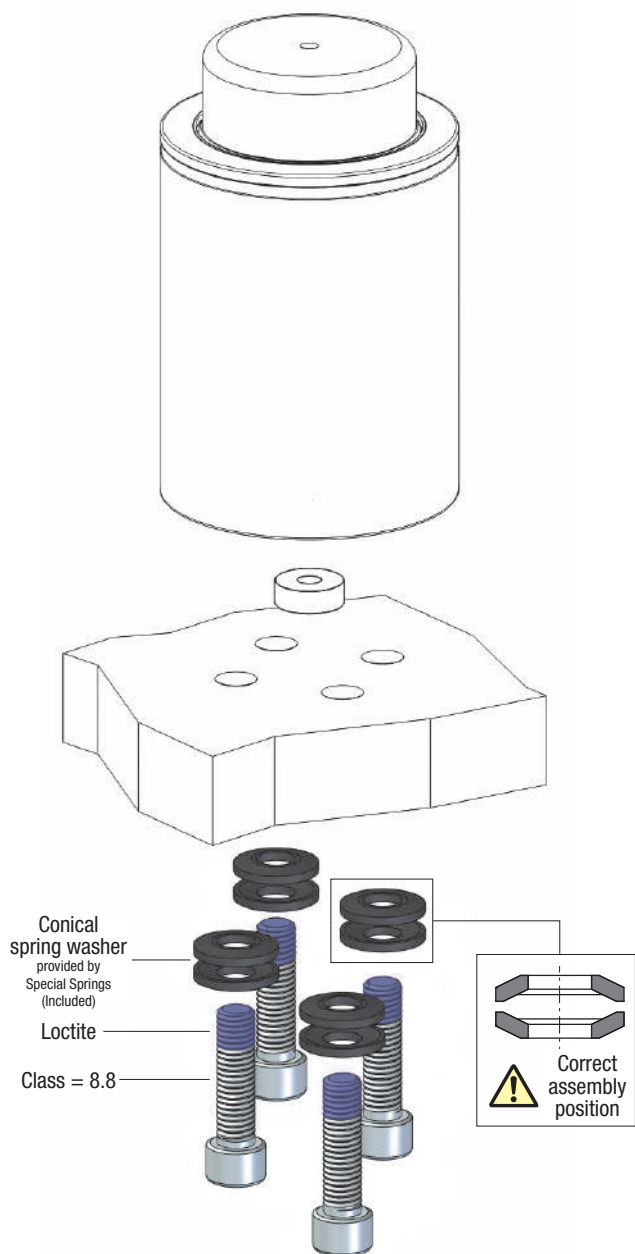

FIXING INFORMATION

- IT** Si raccomanda di installare i cilindri ad azoto nelle versioni "Self Contained" e "Easy Manifold" rispettando le indicazioni qui sotto.
- EN** It is recommended to install gas springs in the "Self-Contained" and "Easy Manifold" versions by following the directions given here below.
- DE** Es wird empfohlen, die Gasdruckfedern der Versionen "Self-Contained" und "Easy Manifold" gemäß den unten aufgeführten Anweisungen einzubauen.
- FR** Il est recommandé d'installer les ressorts à gaz dans les versions "Self-Contained" (autonome) et "Easy Manifold" en suivant les instructions données ci-dessous.
- ES** Se recomienda instalar los cilindros de gas en las versiones "Self-Contained" (autónomo) y "Easy Manifold" siguiendo las instrucciones facilitadas a continuación.
- PT** Se recomenda fixar os cilindros **autonomos** e os para "Easy Manifold", conforme as instruções abaixo.

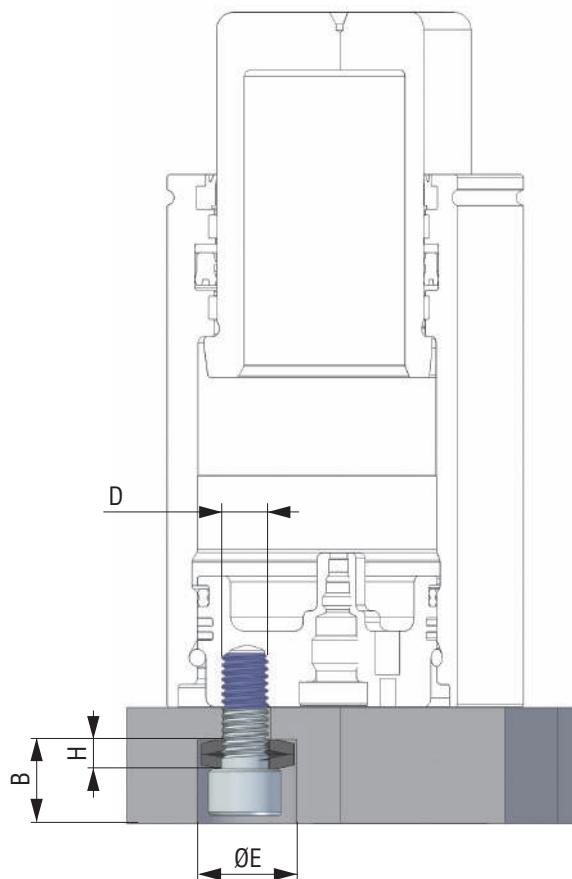

Model	Conical spring washer code	Ø E		B		H		D	
		mm	inch	mm	inch	mm	inch		
ML 1000 D / ML 1800 D MP 500 A / MP 1000 A MQ 700 A	49RC06A	≥ 10,25	≥ .40	≥ 9,15	≥ .36	3,15	.12	M6	 ISO 4762 class 8.8
ML 3000 D	49RCHS08A	≥ 17,3	≥ .68	≥ 12	≥ .47	4	.16	M8	
ML 4700 D / ML 7500 D MP 2000 A / MP 3000 A	49RC08A	≥ 18,3	≥ .72	≥ 12	≥ .47	4	.16	M8	
ML 12000 D	49RC10A	≥ 23,3	≥ .92	≥ 15	≥ .59	5	.20	M10	



THIS PAGE IS INTENTIONALLY LEFT BLANK



FLANGE MOUNTS



- IT** La seguente tabella indica i riferimenti Special Springs per ogni standards. Vedi esempio sotto riportato.
- EN** The following table shows the references for each Special Springs standards. See example below.
- DE** Die folgende Tabelle zeigt die Verweise für jede Special Springs Standards. Siehe Beispiel unten.
- FR** Le tableau suivant indique les références pour chacune des normes spéciales Springs. Voir l'exemple ci-dessous.
- ES** La siguiente tabla muestra las equivalencias de cada modelo Special Springs. Ver ejemplo en la parte inferior de esta hoja.
- PT** A tabela a seguir mostra as referências para cada normas especiais molas. Veja o exemplo abaixo.

Reference to standards	Standards	
0	//	Special Springs
1	ISO 11901-2	
2	VDI 3003	
3	B2 4009	BMW
4	W-DX35-62M	Ford
5	W-DX35-80M	Ford
6	W-DX40-80M	Ford
7	90.25.01	General Motors
8	90.25.02	General Motors
9	90.25.03	General Motors
10	90.25.04	General Motors
11	90.25.06	General Motors
12	90.25.07	General Motors
13	90.25.455	General Motors
14	B8 0132 110 008 801	Mercedes Benz
15	B8 0138 100 000 001	Mercedes Benz

Reference to standards	Standards	
16	B8 0134 300 000 001	Mercedes Benz
17	B8 0134 400 008 801	Mercedes Benz
18	B8 0138 200 000 001	Mercedes Benz
19	E24.54.815.G	Peugeot - Citroën
20	EM24.54.700	Renault
21	39D 848	Volkswagen
22	075.90.70	FCA
23	075.90.75	FCA
24	075.90.80	FCA
25	075.90.85	FCA
26	075.90.90	FCA
27	075.90.95	FCA
28	075.90.40	FCA
29	K32D2-2400-50	Nissan
30	B8 0134 500 008 801	Mercedes Benz

How to read the table

CODE	Reference to standards	A		B		Ø C		D		Ø E		Ø F		Ø G		Ø H		I		L	
		mm	inch	mm	inch	mm	inch	mm	inch	mm	inch	mm	inch	mm	inch	mm	inch	mm	inch	mm	inch
FB 45	1-2-10-19-20	70	2.76	50	1.97	20	0.79	20	0.79	15	0.59	15	0.59	9	0.35	9	0.35	14	0.55	12	0.47

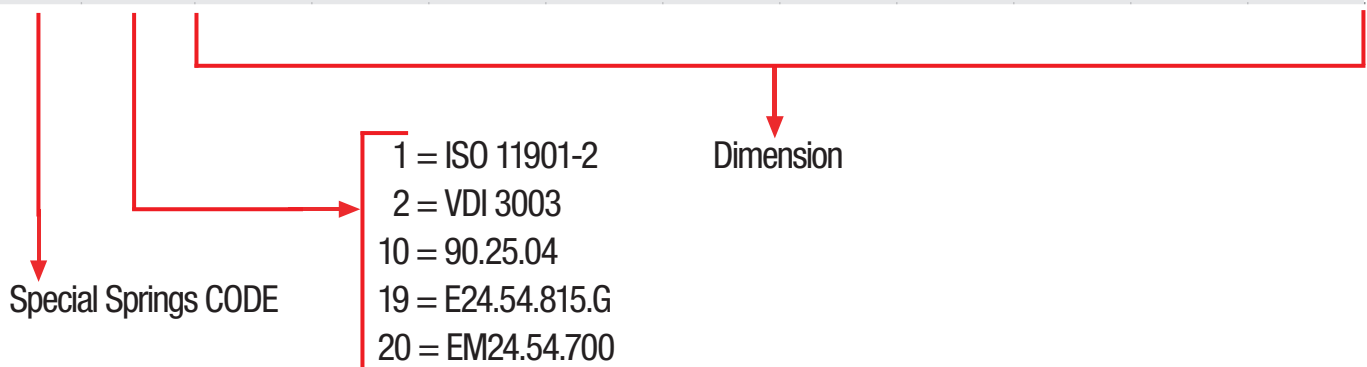

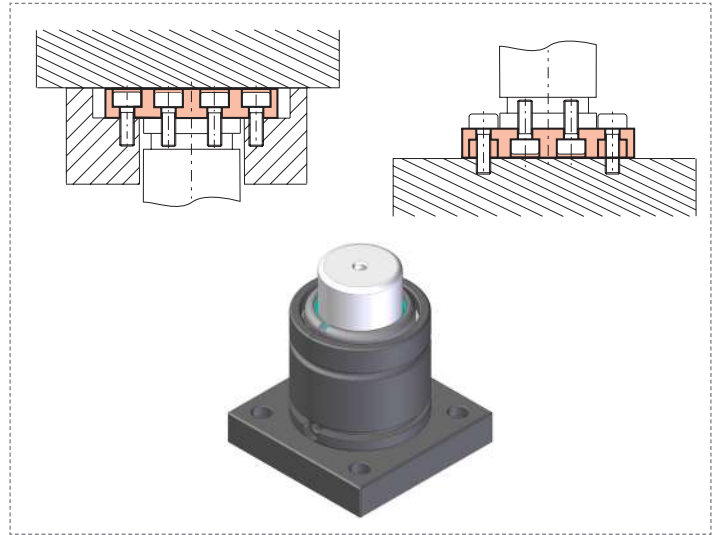
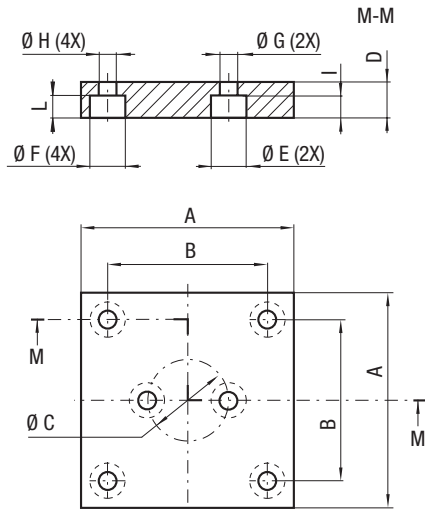

CODE	Reference to standards	A		B		ØC		D		ØE		ØF		ØG		ØH		I		L	
		mm	inch	mm	inch	mm	inch	mm	inch	mm	inch	mm	inch	mm	inch	mm	inch	mm	inch	mm	inch
FB 45	1-2-10-19-20	70	2.76	50	1.97	20	0.79	20	0.79	15	0.59	15	0.59	9	0.35	9	0.35	14	0.55	12	0.47
FB 50	1-2-10-19-20	75	2.95	56,5	2.22	20	0.79	20	0.79	15	0.59	15	0.59	9	0.35	9	0.35	14	0.55	12	0.47
FB 63	0	100	3.94	73,5	2.89	20	0.79	20	0.79	15	0.59	18	0.71	9	0.35	11	0.43	12	0.47	12	0.47

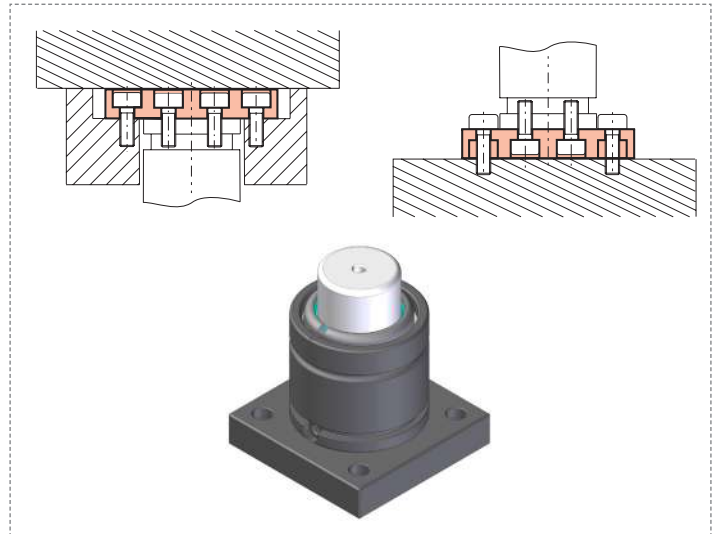
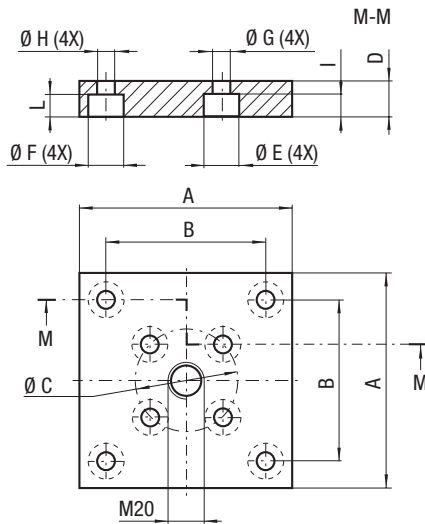

CODE	Reference to standards	A		B		ØC		D		ØE		ØF		ØG		ØH		I		L	
		mm	inch	mm	inch	mm	inch	mm	inch	mm	inch	mm	inch	mm	inch	mm	inch	mm	inch	mm	inch
FB 75	1-2-10-19-20	100	3.94	73,5	2.89	40	1.57	20	0.79	15	0.59	18	0.71	9	0.35	11	0.43	14	0.55	12	0.47
FB 95	1-2-10-19-20	120	4.72	92	3.62	60	2.36	20	0.79	15	0.59	20	0.79	9	0.35	13,5	0.53	14	0.55	13	0.51
FB 120	1-2-10-19-20	140	5.51	109,5	4.31	80	3.15	20	0.79	18	0.71	20	0.79	11	0.43	13,5	0.53	15	0.59	13	0.51
FB 150	1-2-10-20	190	7.48	138	5.43	100	3.94	25	0.98	18	0.71	26	1.02	11	0.43	17,5	0.69	15	0.59	17	0.67
FB 195	1-2-10-20	210	8.27	170	6.69	120	4.72	25	0.98	20	0.79	26	1.02	13,5	0.53	17,5	0.69	13	0.51	17	0.67

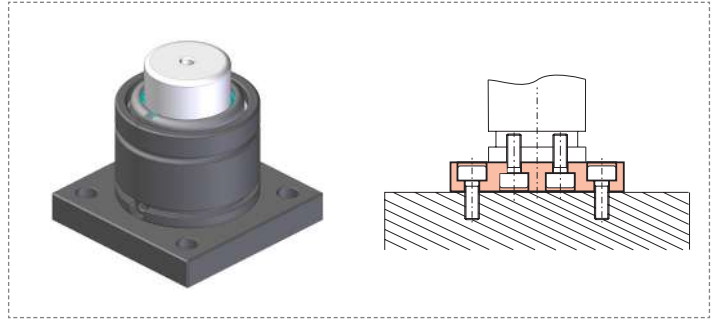
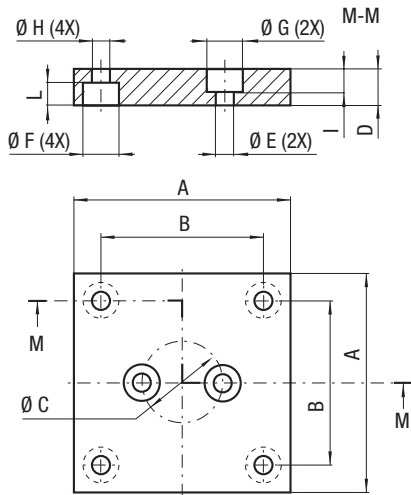

CODE	Reference to standards	A		B		Ø C		D		Ø E		Ø F		Ø G		Ø H		I		L	
		mm	inch	mm	inch	mm	inch	mm	inch	mm	inch	mm	inch	mm	inch	mm	inch	mm	inch	mm	inch
FBA 45	20	70	2.76	50	1.97	20	0.79	20	0.79	9	0.35	18	0.71	15	0.59	11	0.43	14	0.55	12	0.47
FBA 50	20	75	2.95	56,5	2.22	20	0.79	20	0.79	9	0.35	18	0.71	15	0.59	11	0.43	14	0.55	12	0.47

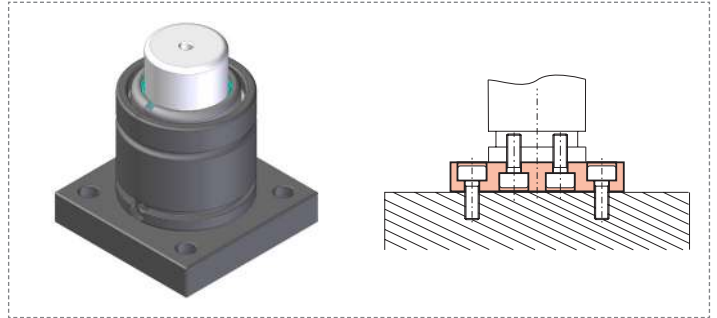
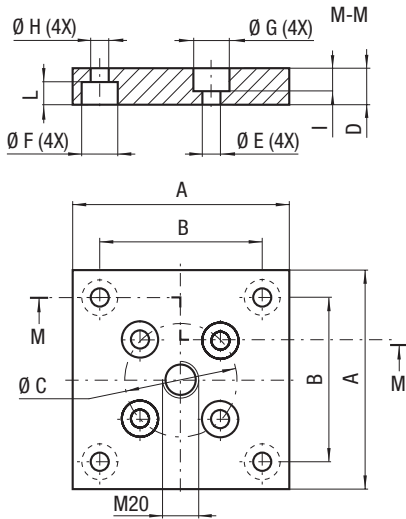

CODE	Reference to standards	A		B		Ø C		D		Ø E		Ø F		Ø G		Ø H		I		L	
		mm	inch	mm	inch	mm	inch	mm	inch	mm	inch	mm	inch	mm	inch	mm	inch	mm	inch	mm	inch
FBA 75	20	100	3.94	73,5	2.89	40	1.57	20	0.79	9	0.35	18	0.71	15	0.59	11	0.43	14	0.55	12	0.47
FBA 95	20	120	4.72	92	3.62	60	1.57	20	0.79	9	0.35	20	0.79	15	0.59	13,5	0.53	14	0.55	13	0.51
FBA 120	20	140	5.51	109,5	4.31	80	3.15	20	0.79	11	0.43	20	0.79	18	0.71	13,5	0.53	15	0.59	13	0.51
FBA 150	20	190	7.48	138	5.43	100	3.94	25	0.98	11	0.43	26	1.02	18	0.71	17,5	0.69	15	0.59	17	0.67
FBA 195	20	210	8.27	170	6.69	120	4.72	25	0.98	13,5	0.53	26	1.02	20	0.79	17,5	0.69	15	0.59	17	0.67

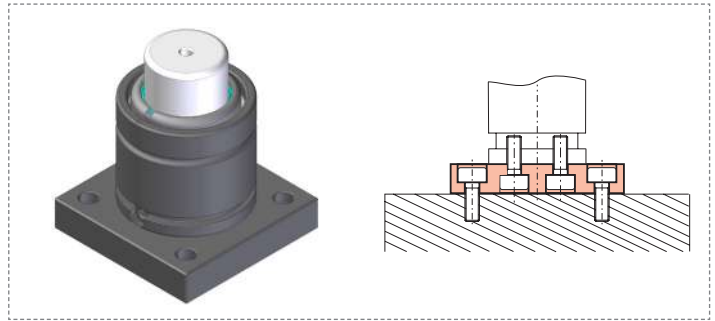
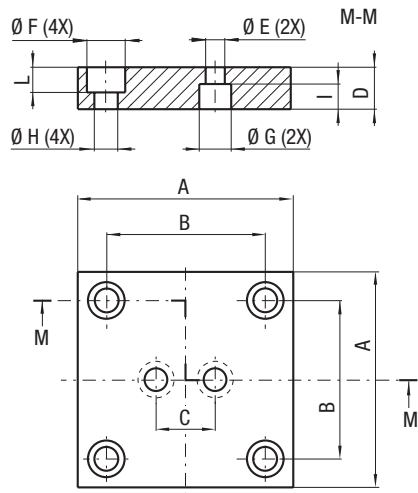

CODE	Reference to standards	A		B		C		D		Ø E		Ø F		Ø G		Ø H		I		L	
		mm	inch	mm	inch	mm	inch	mm	inch	mm	inch	mm	inch	mm	inch	mm	inch	mm	inch	mm	inch
FBB 45	3-14	70	2.76	50	1.97	20	0.79	20	0.79	9	0.35	15	0.59	15	0.59	9	0.35	12	0.47	12	0.47
FBB 50	3-14	75	2.95	56,5	2.22	20	0.79	20	0.79	9	0.35	15	0.59	15	0.59	9	0.35	12	0.47	12	0.47
FBB 63	3-14	100	3.94	73,5	2.89	20	0.79	20	0.79	9	0.35	18	0.71	15	0.59	11	0.43	12	0.47	12	0.47

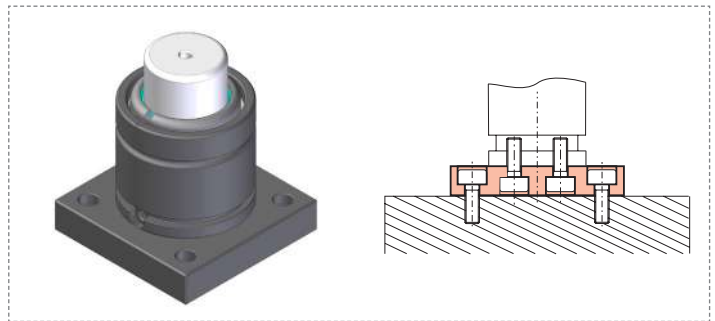
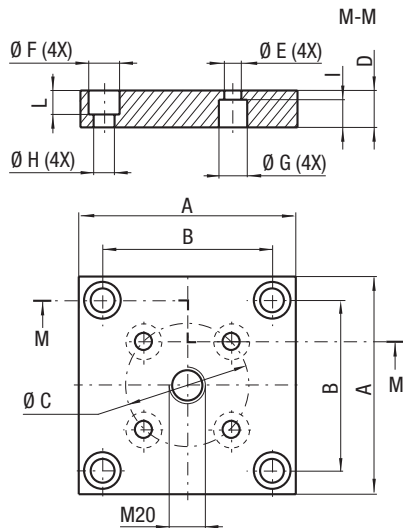

CODE	Reference to standards	A		B		Ø C		D		Ø E		Ø F		Ø G		Ø H		I		L	
		mm	inch	mm	inch	mm	inch	mm	inch	mm	inch	mm	inch	mm	inch	mm	inch	mm	inch	mm	inch
FBB 75	3-14	100	3.94	73,5	2.89	40	1.57	20	0.79	9	0.35	18	0.71	15	0.59	11	0.43	12	0.47	14	0.55
FBB 95	3-14	120	4.72	92	3.62	60	2.36	20	0.79	9	0.35	20	0.79	15	0.59	13,5	0.53	14	0.55	13	0.51
FBB 120	3-14	140	5.51	109,5	4.31	80	3.15	20	0.79	11	0.43	20	0.79	18	0.71	13,5	0.53	15	0.59	13	0.51
FBB 150 A	3-14	190	7.48	138	5.43	100	3.94	20	0.79	11	0.43	20	0.79	18	0.71	13,5	0.53	15	0.59	13	0.51
FBB 195	14	210	8.27	170	6.69	120	4.72	25	0.98	13,5	0.53	26	1.02	20	0.79	17,5	0.69	15	0.59	17	0.67

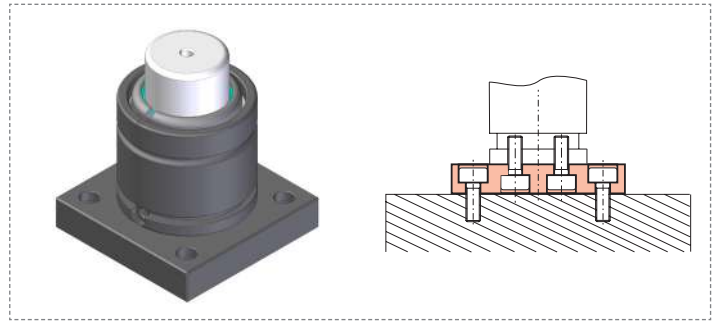
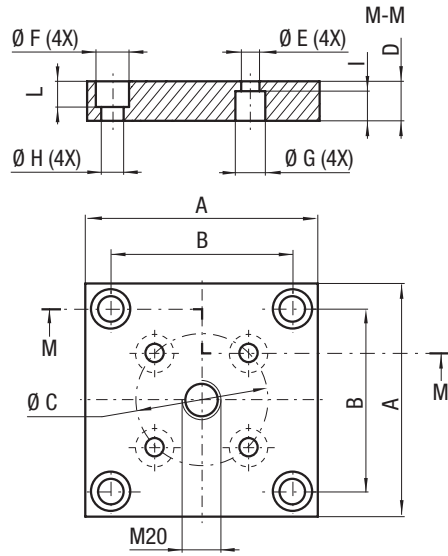

CODE	Reference to standards	A		B		Ø C		D		Ø E		Ø F		Ø G		Ø H		I		L	
		mm	inch	mm	inch	mm	inch	mm	inch	mm	inch	mm	inch	mm	inch	mm	inch	mm	inch	mm	inch
FBC75	0	100	3.94	73,5	2.89	40	1.57	20	0.79	9	0.35	18	0.71	15	0.59	11	0.43	12	0.47	15	0.55

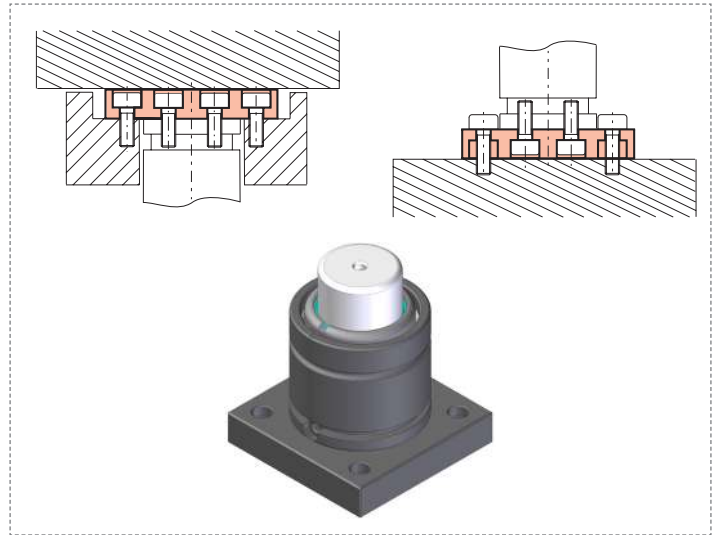
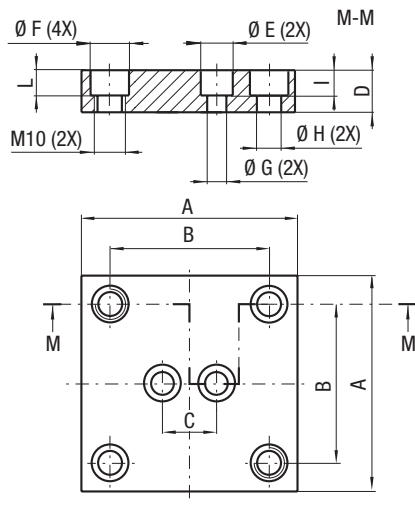

CODE	Reference to standards	A		B		C		D		Ø E		Ø F		Ø G		Ø H		I		L	
		mm	inch	mm	inch	mm	inch	mm	inch	mm	inch	mm	inch	mm	inch	mm	inch	mm	inch	mm	inch
FBD 45	3	70	2.76	50	1.97	20	0.79	20	0.79	15	0.59	15	0.59	9	0.35	9	0.35	12	0.47	12	0.47
FBD 50	3	75	2.95	56,5	2.22	20	0.79	20	0.79	15	0.59	15	0.59	9	0.35	9	0.35	12	0.47	12	0.47

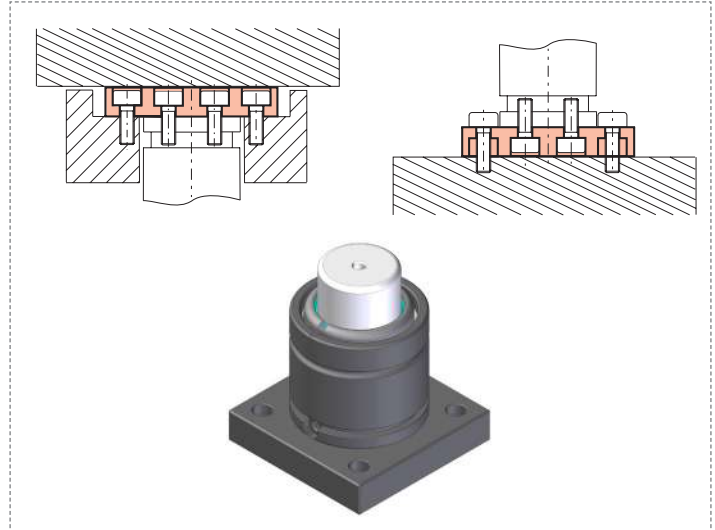
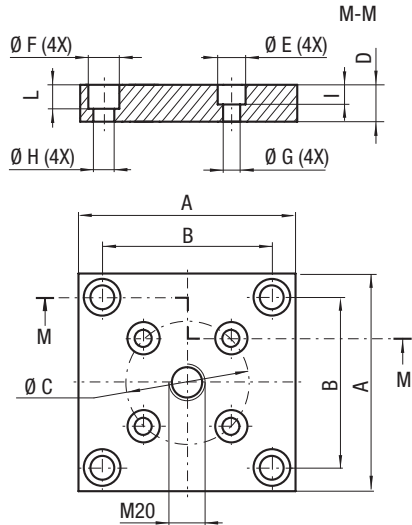

CODE	Reference to standards	A		B		Ø C		D		Ø E		Ø F		Ø G		Ø H		I		L	
		mm	inch	mm	inch	mm	inch	mm	inch	mm	inch	mm	inch	mm	inch	mm	inch	mm	inch	mm	inch
FBD 75	3	100	3.94	73,5	2.89	40	1.57	20	0.79	15	0.59	18	0.71	9	0.35	11	0.43	12	0.47	15	0.59
FBD 150	3-8	190	7.48	138	5.43	100	3.94	20	0.79	18	0.71	26	1.02	11	0.43	17,5	0.69	15	0.59	17	0.67



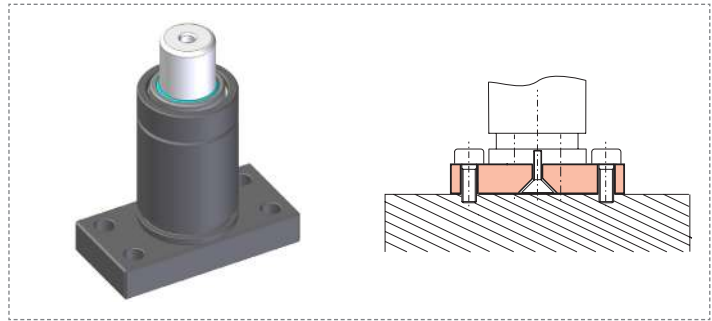
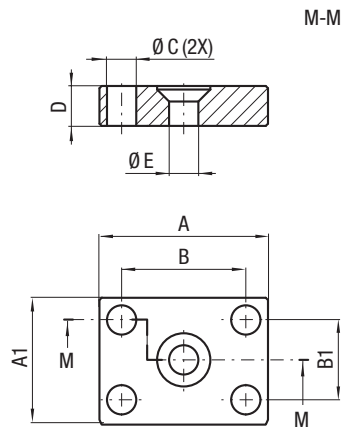

CODE	Reference to standards	A		A1		B		B1		Ø C		D		Ø E	
		mm	inch	mm	inch	mm	inch	mm	inch	mm	inch	mm	inch	mm	inch
FBE 19	0	38	1.50	28	1.10	28	1.10	18	0.71	6,6	0.26	9	0.35	6,6	0.26
FBE 25	0	44	1.73	28	1.10	34	1.34	18	0.71	6,6	0.26	9	0.35	6,6	0.26

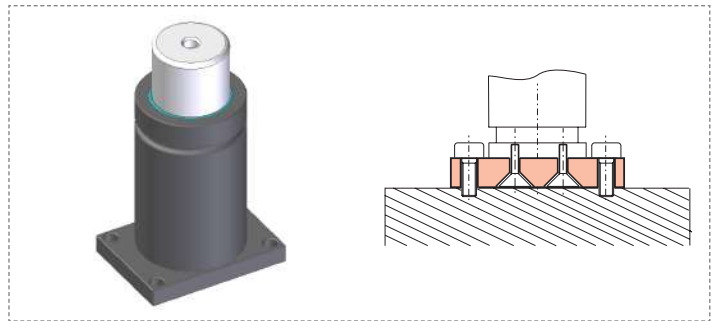
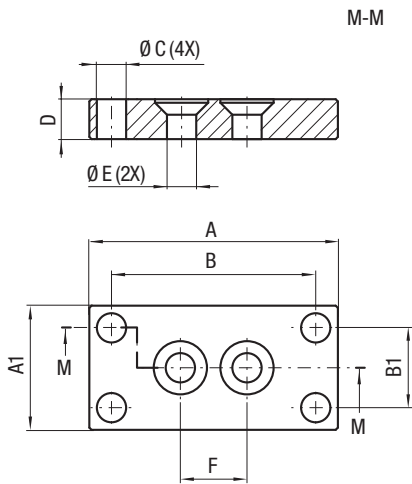

CODE	Reference to standards	A		A1		B		B1		Ø C		D		Ø E		F	
		mm	inch	mm	inch	mm	inch	mm	inch	mm	inch	mm	inch	mm	inch		
FBE 32	0	51	2.01	32	1.26	41	1.61	22	0.87	6.6	0.26	9	0.35	6,6	0.26	15	0.59
FBE 38	0	57	2.24	38	1.50	47	1.85	28	1.10	6.6	0.26	9	0.35	6,6	0.26	20	0.79
FBE 50	0	69	2.72	50	1.97	59	2.32	40	1.57	6.6	0.26	9	0.35	9	0.35	20	0.79
FBE 63	0	84	3.31	65	2.56	70	2.76	50	1.97	6.6	0.26	9	0.35	9	0.35	20	0.79

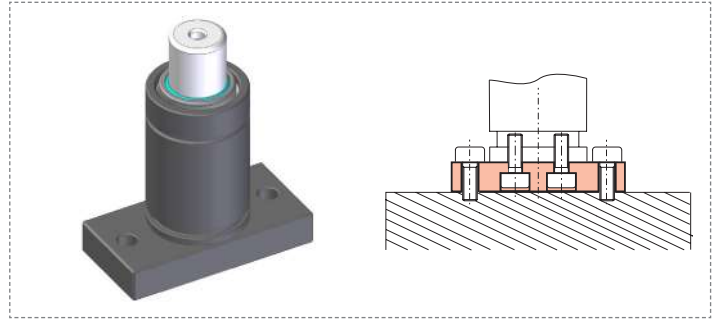
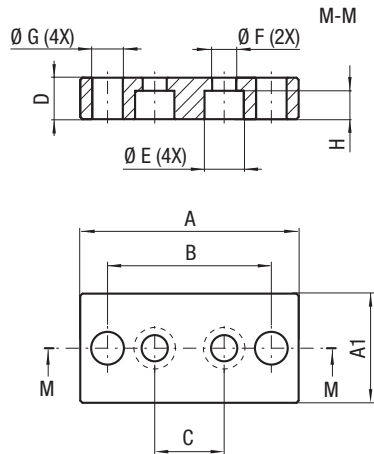

CODE	Reference to standards	A		A1		B		C		D		Ø E		Ø F		Ø G		H	
		mm	inch	mm	inch	mm	inch	mm	inch	mm	inch	mm	inch	mm	inch	mm	inch	mm	inch
FBF 45	20-29	90	3.54	45	1.77	70	2.76	20	0.79	16	0.63	14	0.55	9	0.35	9	0.35	10	0.39
FBF 50	20-29	100	3.94	50	1.97	75	2.95	31,8	1.25	19	0.75	18	0.71	11	0.43	14	0.55	13	0.51
FBFA 50	20-29	100	3.94	50	1.97	75	2.95	20	0.79	19	0.75	14	0.55	9	0.35	14	0.55	13	0.51

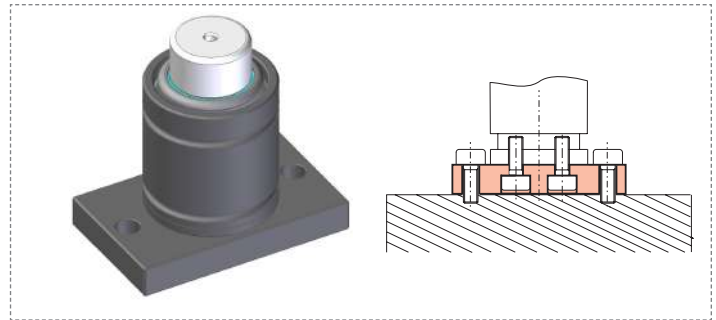
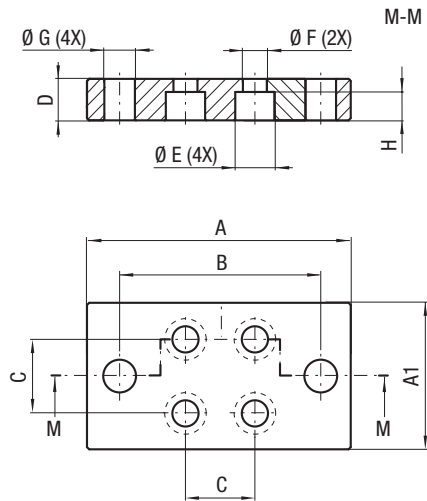

CODE	Reference to standards	A		A1		B		C		D		Ø E		Ø F		Ø G		H	
		mm	inch	mm	inch	mm	inch	mm	inch	mm	inch	mm	inch	mm	inch	mm	inch	mm	inch
FBF 75	20-29	130	5.12	80	3.15	105	4.13	38,1	1.50	19	0.75	20	0.79	14	0.55	14	0.55	13	0.51
FBFA 75	20-29	130	5.12	80	3.15	105	4.13	28,3	1,11	19	0.75	14	0.55	9	0.35	14	0.55	13	0.51
FBF 95	20-29	150	5.91	100	3.94	125	4.92	53,9	2,12	19	0.75	20	0.79	14	0.55	14	0.55	13	0.51
FBFA 95	20-29	150	5.91	100	3.94	125	4.92	42,4	1,67	19	0.75	14	0.55	9	0.35	14	0.55	13	0.51
FBF 120	20-29	170	6.69	120	4.72	145	5.71	57,1	2,25	19	0.75	20	0.79	14	0.55	14	0.55	13	0.51

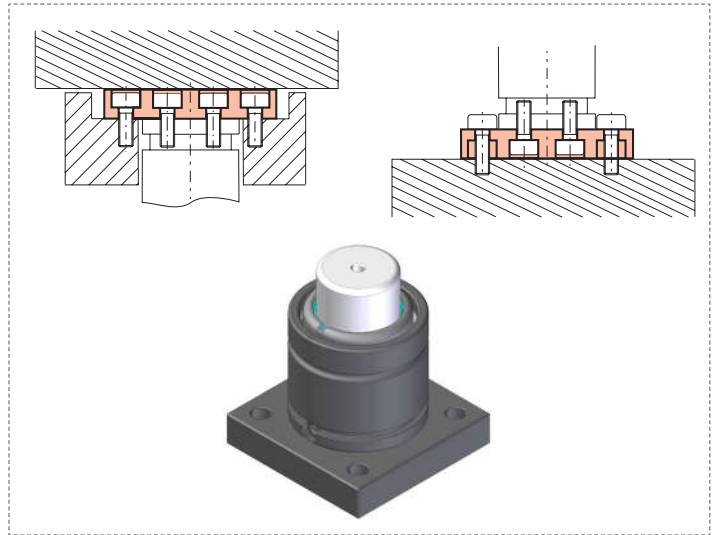
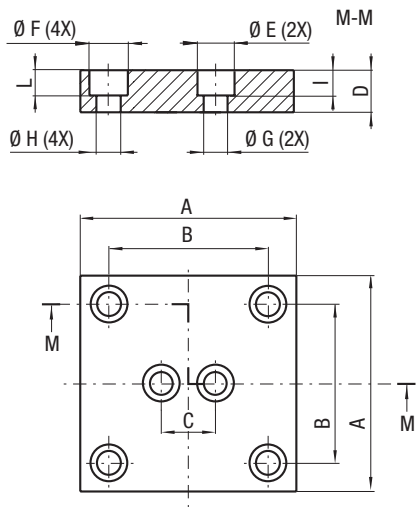

CODE	Reference to standards	A		B		C		D		$\varnothing E$		$\varnothing F$		$\varnothing G$		$\varnothing H$		I		L	
		mm	inch	mm	inch	mm	inch	mm	inch	mm	inch	mm	inch	mm	inch	mm	inch	mm	inch	mm	inch
FBH 50	19	85	3.35	62	2.44	31,8	1.25	25	0.98	18	0.71	18	0.71	11	0.43	11	0.43	13	0.51	13	0.51

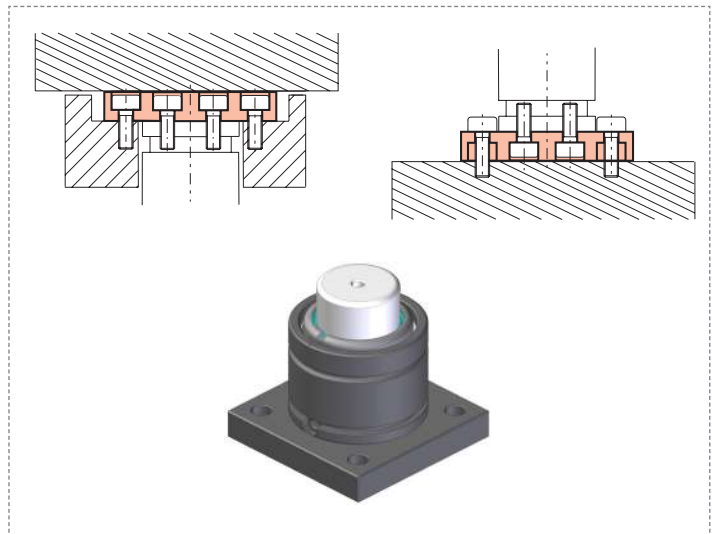
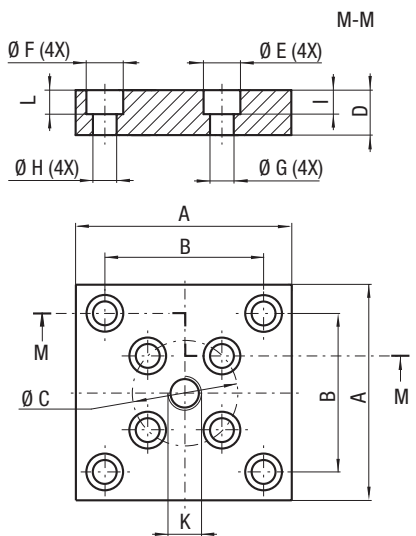

CODE	Reference to standards	A		B		$\varnothing C$		D		$\varnothing E$		$\varnothing F$		$\varnothing G$		$\varnothing H$		I		L		K
		mm	inch	mm	inch	mm	inch	mm	inch	mm	inch	mm	inch	mm	inch	mm	inch	mm	inch	mm	inch	
FBH 75	19	100	3.94	76	2.99	53,9	2.12	25	0.98	21	0.83	21	0.83	13	0.51	13	0.51	14	0.55	13	0.51	M16
FBH 95	19	132	5.20	95	3.74	76,2	3.00	30	1.18	20	0.79	26	1.02	13	0.51	17	0.67	14	0.55	18	0.71	M20

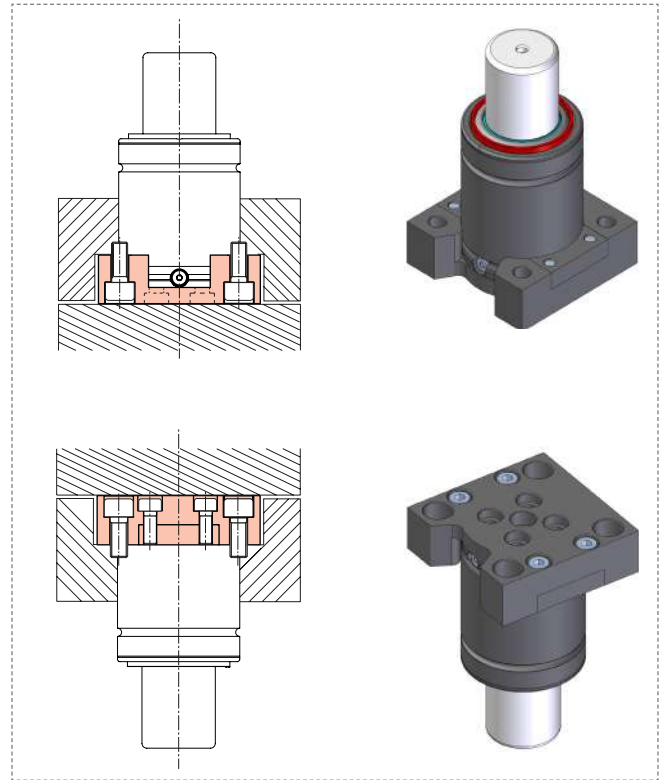
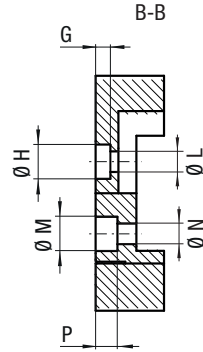
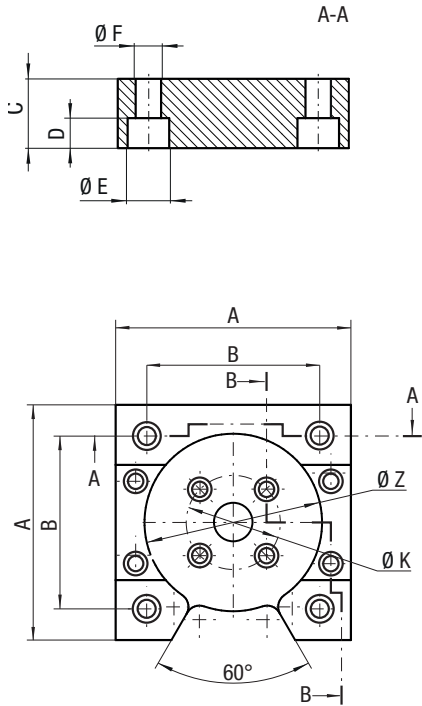

CODE	Reference to standards	A		B		C		D		ØE		ØF		G	ØH		ØL		ØM		ØN		P		ØZ		ØK		
		mm	inch	mm	inch	mm	inch	mm	inch	mm	inch	mm	inch		mm	inch	mm	inch	mm	inch	mm	inch	mm	inch	mm	inch	mm	inch	mm
FBM 50	4	80	3.15	56,5	2.22	30	1.18	17	0.67	18	0.71	11	0.43	9,6	0.38	15	0.59	9	0.35	15	0.59	9	0.35	6,5	0.26	50,5	1.99	20	0.79
FBM 63	4	100	3.94	73,5	2.89	30	1.18	17	0.67	18	0.71	11	0.43	9,6	0.38	15	0.59	9	0.35	15	0.59	9	0.35	6,5	0.26	63,5	2.50	40	1.57
FBM 75	4	100	3.94	73,5	2.89	30	1.18	17	0.67	18	0.71	11	0.43	9,6	0.38	15	0.59	9	0.35	15	0.59	9	0.35	6,5	0.26	75,5	2.97	40	1.57
FBM 95	4	120	4.72	92	3.62	30	1.18	15	0.59	20	0.79	13,5	0.53	9,6	0.38	15	0.59	9	0.35	15	0.59	9	0.35	6,5	0.26	95,5	3.76	60	2.36
FBM 120	4	140	5.51	109,5	4.31	30	1.18	15	0.59	20	0.79	13,5	0.53	9,6	0.38	15	0.59	9	0.35	15	0.59	9	0.35	6,5	0.26	120,5	4.74	80	3.15
FBM 150	4	190	7.48	138	5.43	30	1.18	10	0.39	26	1.02	17,5	0.69	9,6	0.38	15	0.59	9	0.35	15	0.59	9	0.35	6,5	0.26	150,5	5.93	100	3.94

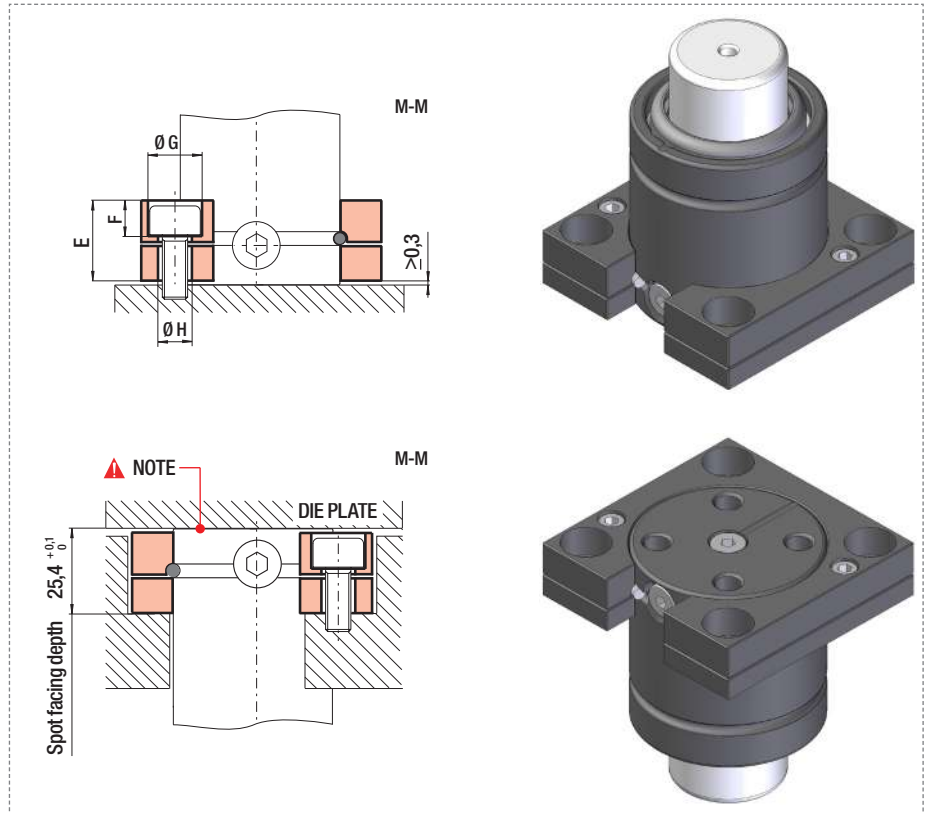
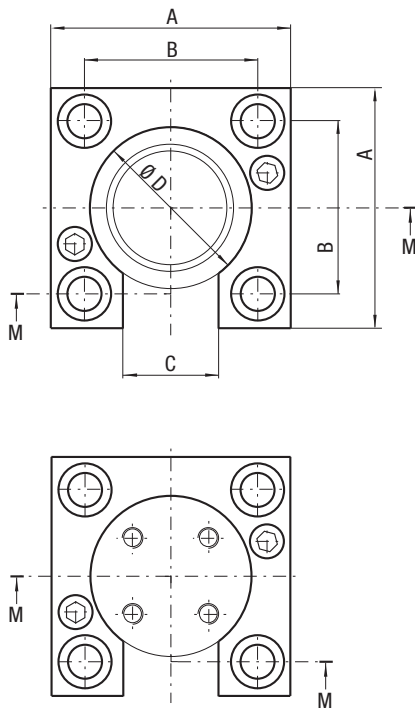

CODE	Reference to standards	A		B		C		Ø D		E		F		Ø G		Ø H	
		mm	inch	mm	inch	mm	inch	mm	inch	mm	inch	mm	inch	mm	inch	mm	inch
FS1 50	0	75	2.95	53,9	2.12	30	1.18	50,5	1.99	25	0.98	11	0.43	17	0.67	11	0.43
FS1 63	0	100	3.94	73,5	2.89	30	1.18	63,5	2.50	25	0.98	11	0.43	17	0.67	11	0.43
FS1 75	0	100	3.94	76,2	3.00	30	1.18	75,5	2.97	25	0.98	13	0.51	20	0.79	13	0.51
FS1 95	0	125	4.92	98,3	3.87	30	1.18	95,5	3.76	25	0.98	13	0.51	20	0.79	13	0.51
FS1 120	0	140	5.51	114,3	4.50	30	1.18	120,5	4.74	25	0.98	13	0.51	20	0.79	13	0.51
FS1 150	0	175	6.89	139,7	5.50	30	1.18	150,5	5.93	25	0.98	17	0.67	25	0.98	17	0.67

! NOTE

- IT** Garantire sempre il contatto tra il piano premente e il fondo del cilindro ad azoto.
- EN** Make sure there is always a contact between the bottom gas spring surface and the die plate.
- DE** Es muss immer ein Kontakt zwischen der Arbeitsfläche der Presse und dem Boden der Gasdruckfeder gewährleistet sein.
- FR** Toujours consentir un contact entre la surface du fond du cylindre et la presse.
- ES** Garantizar siempre el contacto entre la base del cilindro y el utillaje.
- PT** Garantir sempre o contato entre o fundo do cilindro e o dispositivo de pressão.

ISO	VDI	BMW	Ford
General Motors	Mercedes Benz	Volkswagen	

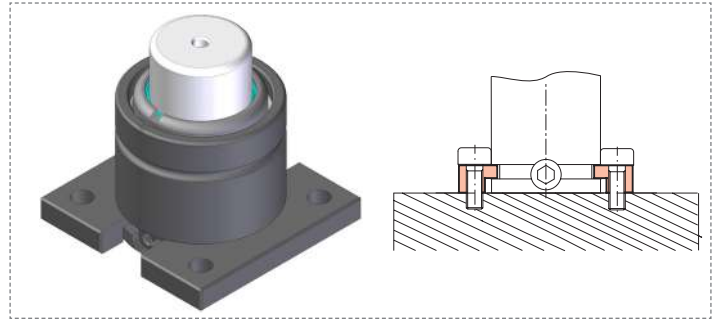
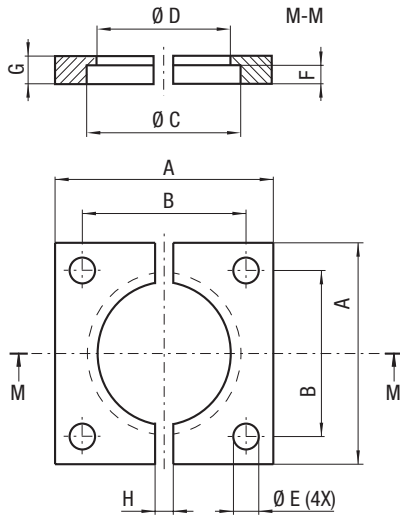

CODE	Reference to standards	A		B		Ø C		Ø D		Ø E		F		G		H	
		mm	inch	mm	inch	mm	inch	mm	inch	mm	inch	mm	inch	mm	inch	mm	inch
FS2 32	1-3-4-7-15	50	1.97	35	1.38	32,5	1.28	28,5	1.12	6,6	0.26	4	0.16	7	0.28	5	0.20
FS2 38	1-3-4-7-15	55	2.17	40	1.57	38,5	1.52	34,5	1.36	7	0.28	4	0.16	7	0.28	5	0.20
FS2 45	1-2-3-4-7-15-21-26	70	2.76	50	1.97	45,5	1.79	41,5	1.63	9	0.35	4	0.16	7	0.28	20	0.79
FS2 50	1-2-3-4-7-15-21-26	75	2.95	56,5	2.22	50,5	1.99	44,5	1.75	9	0.35	8	0.31	12	0.47	24	0.95
FS2 63	0	85	3.35	63,5	2.50	63,5	2.50	57,5	2.26	11	0.43	8	0.31	12	0.47	24	0.95
FS2 75	1-2-3-4-7-15-21-26	100	3.94	73,5	2.89	75,5	2.97	68,5	2.70	11	0.43	8	0.31	12	0.47	24	0.95
FS2 95	1-2-3-4-7-15-21-26	120	4.72	92	3.62	95,5	3.76	88,5	3.48	13,5	0.53	8	0.31	12	0.47	24	0.95
FS2 120	1-2-3-4-7-15-21-26	140	5.51	109,5	4.31	120,5	4.74	113,5	4.47	13,5	0.53	8	0.31	12	0.47	24	0.95
FS2 150	1-2-3-4-7-15-21-26	190	7.48	138	5.43	150,5	5.93	143,5	5.65	17,5	0.69	8	0.31	12	0.47	24	0.95
FS2 195	1-2-4-7-15-21-26	210	8.27	170	6.69	195,5	7.70	188	7.40	17,5	0.69	8	0.31	13	0.51	24	0.95

VDI	BMW	Ford	Mercedes Benz
Volkswagen			

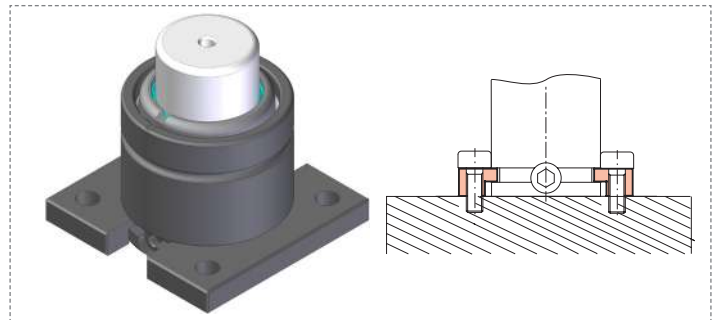
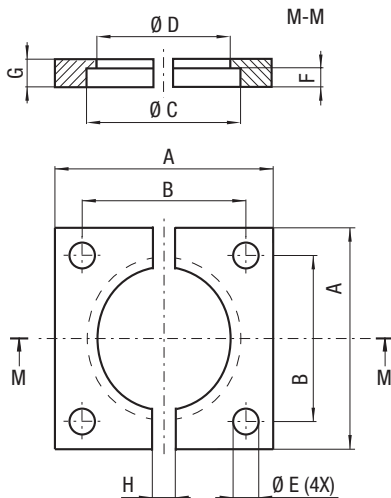

CODE	Reference to standards	A		B		Ø C		Ø D		Ø E		F		G		H	
		mm	inch	mm	inch	mm	inch	mm	inch	mm	inch	mm	inch	mm	inch	mm	inch
FS2B 32	2-21-26	50	1.97	35	1.38	32,5	1.28	28,5	1.12	6,6	0.26	4	0.16	7	0.28	12	0.47
FS2B 38	2-21-26	55	2.17	40	1.57	38,5	1.52	34,5	1.36	6,6	0.26	4	0.16	7	0.28	12	0.47
FS2B 63	2-3-4-15-21	100	3.94	73,5	2.89	64	2.52	57,5	2.60	11	0.43	8	0.32	12	0.47	24	0.95

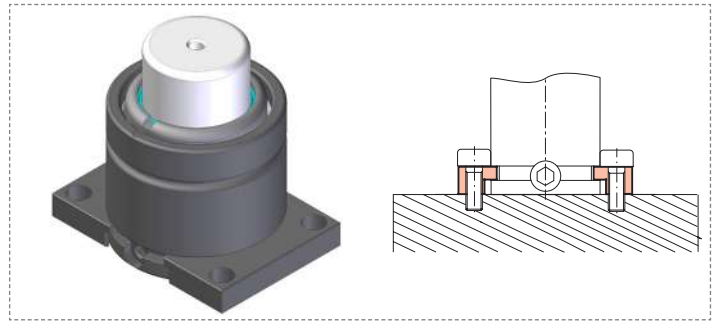
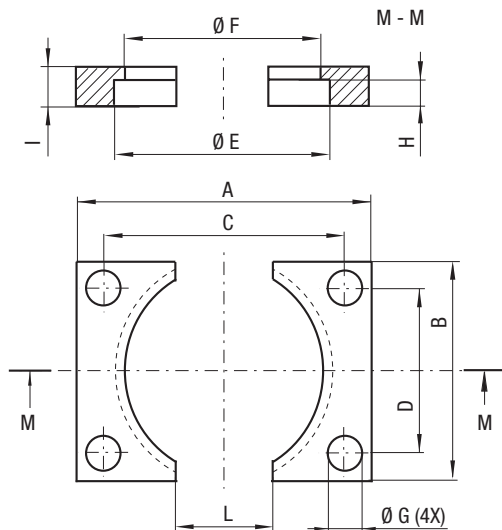

CODE	Reference to standards	A		B		C		D		Ø E		Ø F		Ø G		H		I		L	
		mm	inch	mm	inch	mm	inch	mm	inch	mm	inch	mm	inch	mm	inch	mm	inch	mm	inch	mm	inch
FS2A 32	0	50	1.97	27	1.06	40	1.57	18	0.71	32,5	1.28	28,5	1.12	6,6	0.26	4	0.16	7	0.28	20	0.79
FS2A 38	0	55	2.17	33	1.30	44	1.73	20	0.79	38,5	1.52	34,5	1.36	6,6	0.26	4	0.16	7	0.28	20	0.79
FS2A 45	0	70	2.76	40	1.57	57	2.24	27	1.06	45,5	1.79	41,5	1.63	9	0.35	4	0.16	7	0.28	25	0.98
FS2A 50	0	75	2.95	45	1.77	62	2.44	32	1.26	50,5	1.99	44,5	1.75	9	0.35	8	0.31	12	0.47	25	0.98
FS2A 63	0	85	3.35	58	2.28	69	2.72	42	1.65	63,5	2.5	57,5	2.26	11	0.43	8	0.31	12	0.47	30	1.18
FS2A 75	0	100	3.94	70	2.76	84	3.31	54	2.13	75,5	2.97	68,5	2.7	11	0.43	8	0.31	12	0.47	30	1.18
FS2A 95	0	120	4.72	90	3.54	100	3.94	70	2.76	95,5	3.76	88,5	3.48	13,5	0.53	8	0.31	12	0.47	40	1.57
FS2A 120	0	140	5.51	115	4.53	120	4.72	95	3.74	120,5	4.74	113,5	4.47	13,5	0.53	8	0.31	12	0.47	50	1.97
FS2A 150	0	190	7.48	145	5.71	165	6.5	120	4.72	150,5	5.93	143,5	5.65	17,5	0.69	8	0.31	12	0.47	60	2.36
FS2A 195	0	210	8.27	190	7.48	185	7.28	165	6.50	195,5	7.70	188	7.40	17,5	0.69	8	0.31	13	0.51	80	3.15

FS2C

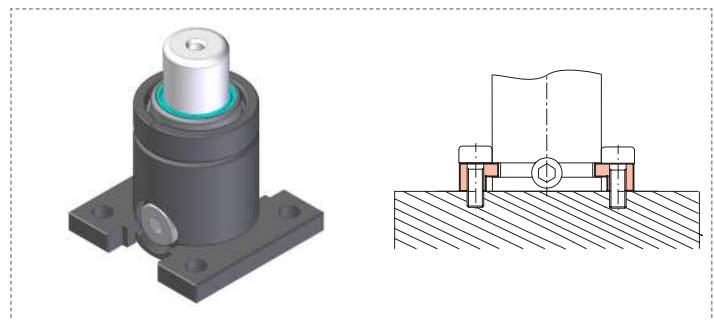
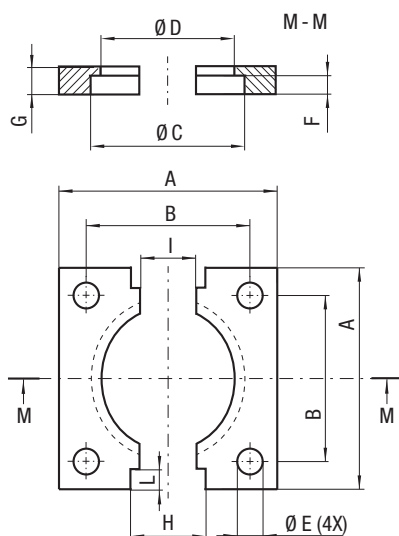

CODE	Reference to standards	A		B		C		D		Ø E		F		G		H		I		L	
		mm	inch	mm	inch	mm	inch	mm	inch	mm	inch	mm	inch	mm	inch	mm	inch	mm	inch	mm	inch
FS2C 32	0	50	1.97	35	1.38	32,5	1.28	28,5	1.12	6,6	0.26	4	0.16	7	0.28	21	0.83	17	0.67	6,5	0.26
FS2C 38	0	55	2.17	40	1.57	38,5	1.52	34,5	1.36	6,6	0.26	4	0.16	7	0.28	21	0.83	17	0.67	6,5	0.26

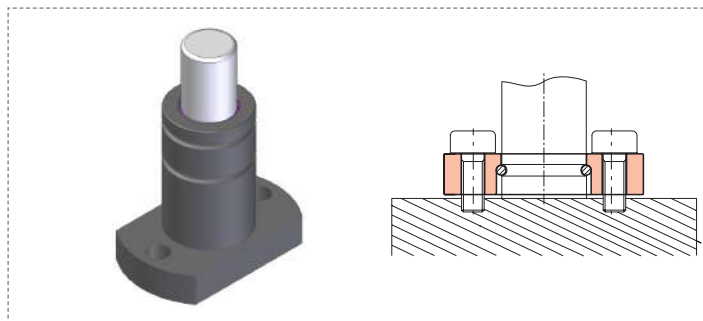
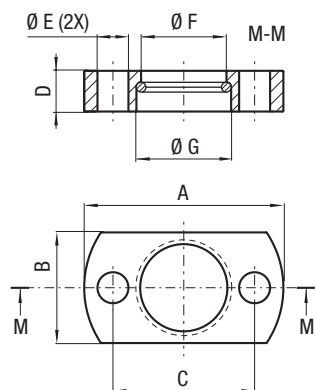

CODE	Reference to standards	A		B		C		D		Ø E		Ø F		Ø G	
		mm	inch	mm	inch	mm	inch	mm	inch	mm	inch	mm	inch	mm	inch
FS3 19	0	45	1.77	25	0.98	32	1.26	9,2	0.36	7	0.28	19,3	0.76	21,4	0.84
FS3 25	0	50	1.97	30	1.18	38	1.50	9,2	0.36	7	0.28	25,3	1.00	27,4	1.08

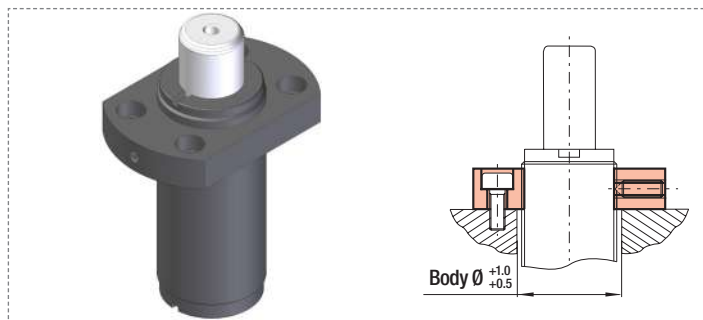
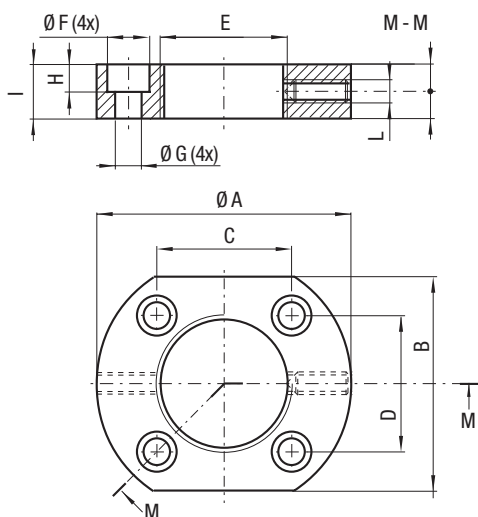

CODE	Reference to standards	Ø A		B		C		D		E	Ø F		Ø G		H		I		L
		mm	inch	mm	inch	mm	inch	mm	inch		mm	inch	mm	inch	mm	inch	mm	inch	
FCA 38	0	75	2.95	50	1.97	50,3	1.98	29	1.14	M 38 x 1,5	14	0.55	9	0.35	8	0.31	12	0.47	M6
⚠ FCA 45	0	90	3.54	60	2.36	60	2.36	34	1.34	M 45 x 1,5	14	0.55	9	0.35	8	0.31	16	0.63	M6
⚠ FCA 50	0-22	100	3.94	66	2.60	66	2.60	38	1.50	M 50 x 1,5	14	0.55	9	0.35	8	0.31	16	0.63	M6

⚠ Phasing out

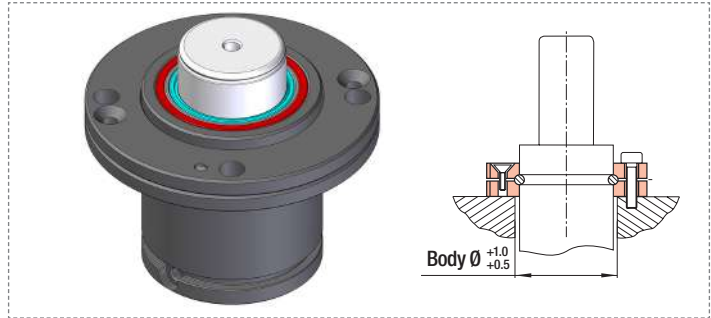
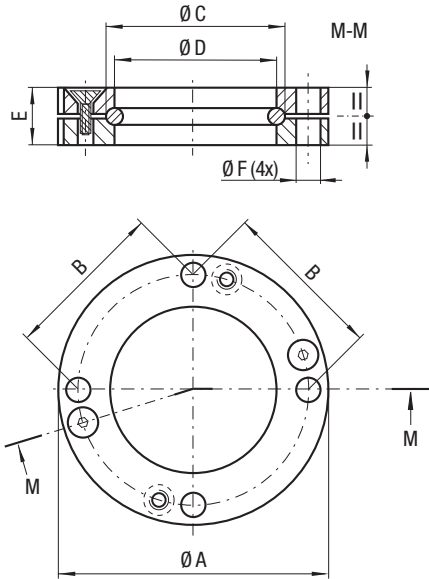

CODE	Reference to standards	Ø A		B		Ø C		Ø D		E		Ø F	
		mm	inch	mm	inch	mm	inch	mm	inch	mm	inch	mm	inch
FCB 50	0	95	3.74	56,5	2.22	52	2.05	50,5	1.99	13	0.51	9	0.35
FCB 63	0	122	4.80	73,5	2.89	66	2.60	63,5	2.50	16	0.63	11	0.43
FCB 75	0	122	4.80	73,5	2.89	78	3.07	75,5	2.97	16	0.63	11	0.43
FCB 95	0	150	5.91	92	3.62	98	3.86	95,5	3.76	18	0.71	13,5	0.53

FCD

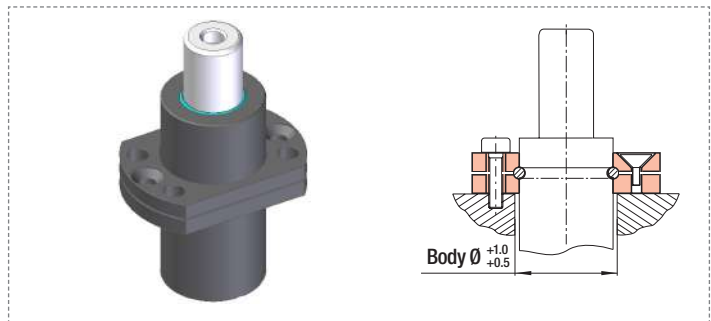
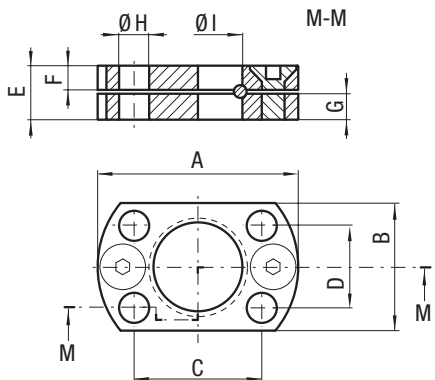

CODE	Reference to standards	A		B		C		D		E		F		G		Ø H		Ø I	
		mm	inch	mm	inch	mm	inch	mm	inch	mm	inch	mm	inch	mm	inch	mm	inch	mm	inch
FCD 19	0	44	1.73	28	1.10	28	1.10	18	0.71	11	0.43	5,2	0.20	5,6	0.22	6,6	0.26	19,5	0.77
FCD 25	0	50	1.97	30	1.18	34	1.34	18	0.71	11	0.43	5,2	0.20	5,6	0.22	6,6	0.26	25,5	1.00
FCD 32	0	57	2.24	39	1.54	40	1.57	22	0.87	11	0.43	5,2	0.20	5,6	0.22	6,6	0.26	32,5	1.28
FCD 38	0	63	2.48	46	1.81	45	1.77	26	1.02	11	0.43	5,2	0.20	5,6	0.22	6,6	0.26	38,5	1.52
FCD 50	0	75	2.95	58	2.28	54	2.13	34	1.34	11	0.43	6,2	0.24	4,6	0.18	6,6	0.26	50,5	1.99
FCD 63	0	98	3.86	76	2.99	74	2.91	40	1.57	13	0.51	8,9	0.35	3,9	0.15	9	0.35	63,5	2.50

Fig. 1

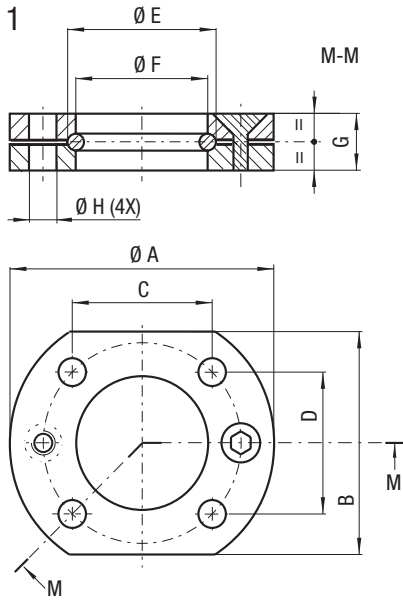
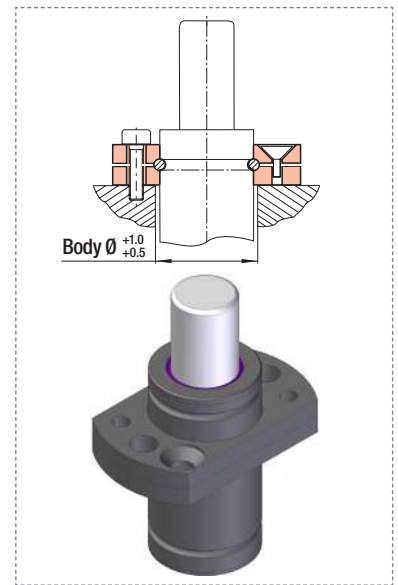
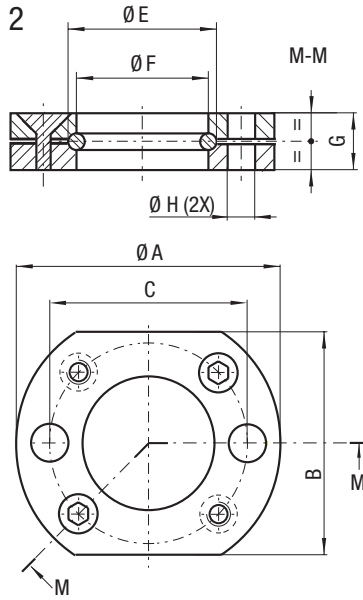
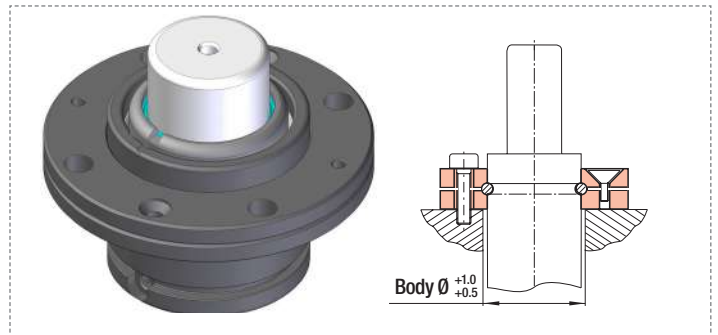
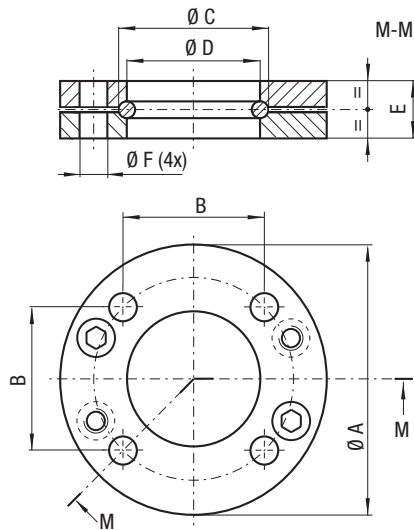

Fig. 2



CODE	Reference to standards	Ø A		B		C		D		Ø E		Ø F		G		Ø H		Rif. Fig
		mm	inch	mm	inch	mm	inch	mm	inch	mm	inch	mm	inch	mm	inch	mm	inch	
FC 12 A	0	34	1.34	21	0.83	24	0.94	-	-	13,7	0.54	12,5	0.49	9	0.35	6,6	0.26	Fig. 2
FC 15 A	0	37	1.36	24	0.94	27	1.06	-	-	16,7	0.66	15,5	0.61	9	0.35	6,6	0.26	
FC 19 B	1-5	44	1.73	25	0.98	30	1.18	12	0.47	21,9	0.86	19,5	0.77	9	0.35	6,6	0.26	Fig. 1
FC 25 B	1-5	50	1.97	30	1.18	34	1.34	18	0.71	27,9	1.10	25,5	1.00	9	0.35	6,6	0.26	
FCC 19 A	2-3-17-21-23	44	1.73	25	0.98	32	1.26	-	-	21	0.83	19,5	0.77	9	0.35	6,6	0.26	Fig. 2
FCC 25 A	2-3-17-19-21-23	50	1.97	30	1.18	38	1.50	-	-	27	1.06	25,5	1.00	9	0.35	6,6	0.26	



CODE	Reference to standards	Ø A		B		Ø C		Ø D		E		Ø F	
		mm	inch	mm	inch	mm	inch	mm	inch	mm	inch	mm	inch
FC 32 A	1-9-16-24	60	2.36	35	1.38	34	1.34	32,5	1.28	9	0.35	7	0.28
FC 38 A	1-9-16-24	68	2.68	40	1.57	40	1.57	38,5	1.52	9	0.35	7	0.28
FC 45 A	1-9-16-24	86	3.39	50	1.97	47	1.85	45,5	1.79	13	0.51	9	0.35
FC 50 A	1-9-16-24	95	3.74	56,5	2.22	54	2.13	50,5	1.99	13	0.51	9	0.35
FC 63 A	0	122	4.80	73,5	2.89	67	2.64	63,5	2.50	16	0.63	11	0.43
FC 75 A	1-9-16-24	122	4.80	73,5	2.89	80	3.15	75,5	2.97	16	0.63	11	0.43
FC 95 A	1-9-16-24	150	5.91	92	3.62	100	3.94	95,5	3.76	18	0.71	13,5	0.53
FC 120 A	1-9-16-24	175	6.89	109,5	4.31	125	4.92	120,5	4.74	21	0.83	13,5	0.53
FC 150 A	1-9-16-24	220	8.66	138	5.43	155	6.10	150,5	5.93	27	1.06	17,5	0.69
FC 195 A	1-9-16-24	290	11.42	170	6.69	200	7.87	195,5	7.70	27	1.06	17,5	0.69

FCQ - FCQC

ISO	VDI	BMW	Ford
General Motors	Volkswagen	Mercedes Benz	

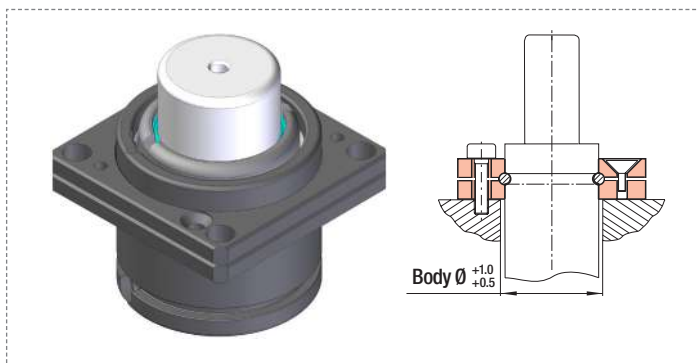
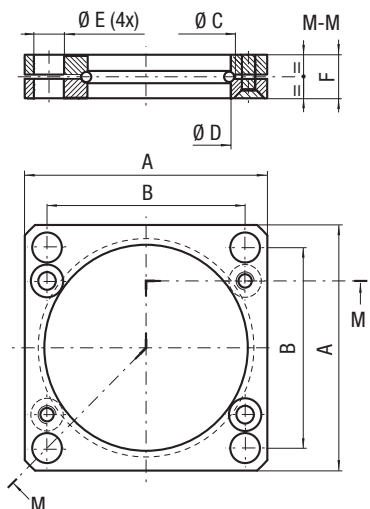

PHASING OUT	NEW	Reference to standards	A		B		Ø C		Ø D		Ø E		F	
			mm	inch	mm	inch	mm	inch	mm	inch	mm	inch	mm	inch
FCQ 32 A	FCQC 32	2-4-8-25-30	45	1.77	35	1.38	34	1.34	32,5	1.28	7	0.28	9	0.26
FCQ 38 A	FCQC 38	1-2-3-4-8-25-30	52	2.05	40	1.57	40	1.57	38,5	1.52	7	0.28	9	0.35
FCQ 45 A	FCQC 45	1-2-3-4-8-25-30	64	2.52	50	1.97	47	1.85	45,5	1.79	9	0.35	13	0.51
FCQ 50 A	FCQC 50	1-2-3-4-8-25-30	70	2.76	56,5	2.22	54	2.13	50,5	1.99	9	0.35	13	0.51
FCQ 63 A	FCQ 63 A	25	90	3.54	73,5	2.89	67	2.64	63,45	2.50	11	0.43	16	0.63
FCQC 63	FCQC 63	2-4-2-30	80	3.15	64	2.52	67	2.64	63,45	2.50	11	0.43	16	0.63
FCQ 75 A	FCQC 75	1-2-3-4-8-25-30	90	3.54	73,5	2.89	80	3.15	75,5	2.97	11	0.43	16	0.63
FCQ 95 A	FCQC 95	1-2-3-4-8-25-30	110	4.33	92	3.62	100	3.94	95,5	3.76	13,5	0.53	18	0.71
FCQ 120 A	FCQC 120	1-2-3-4-8-25-30	130	5.12	109,5	4.31	125	4.92	120,5	4.74	13,5	0.53	21	0.83
FCQ 150 A	FCQC 150	1-2-3-4-8-25-30	162	6.38	138	5.43	155	6.10	150,5	5.93	17,5	0.69	27	1.06
FCQ 195 A	FCQC 195	1-2-4-8-25-30	210	8.27	170	6.69	200	7.87	195,5	7.70	17,5	0.69	27	1.06

FCQB - FCQD

For KE series only

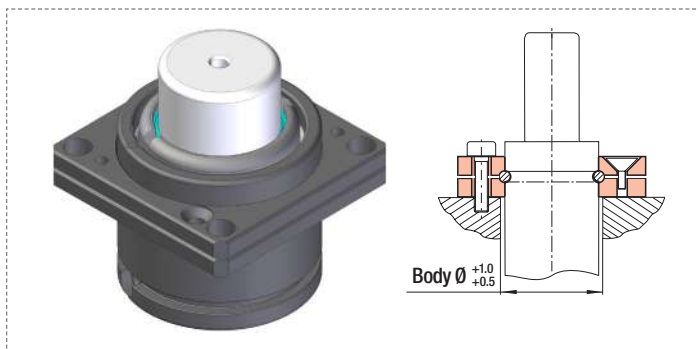
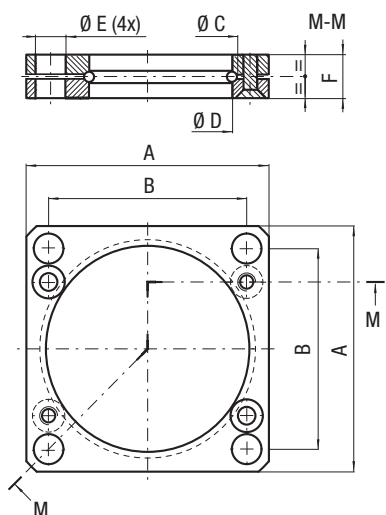

CODE	Reference to standards	A		B		Ø C		Ø D		Ø E		F	
		mm	inch	mm	inch	mm	inch	mm	inch	mm	inch	mm	inch
FCQB 50	0	70	2.76	56,5	2.22	52	2.05	50,5	1.99	9	0.35	13	0.51
FCQB 63	0	90	3.54	73,5	2.89	66	2.60	63,5	2.50	11	0.43	16	0.63
FCQD 63	0	80	3.15	64	2.52	66	2.60	63,5	2.50	11	0.43	16	0.63
FCQB 75	0	90	3.54	73,5	2.89	78	3.07	75,5	2.97	11	0.43	16	0.63
FCQB 95	0	110	4.33	92	3.62	98	3.86	95,5	3.76	13,5	0.53	18	0.71

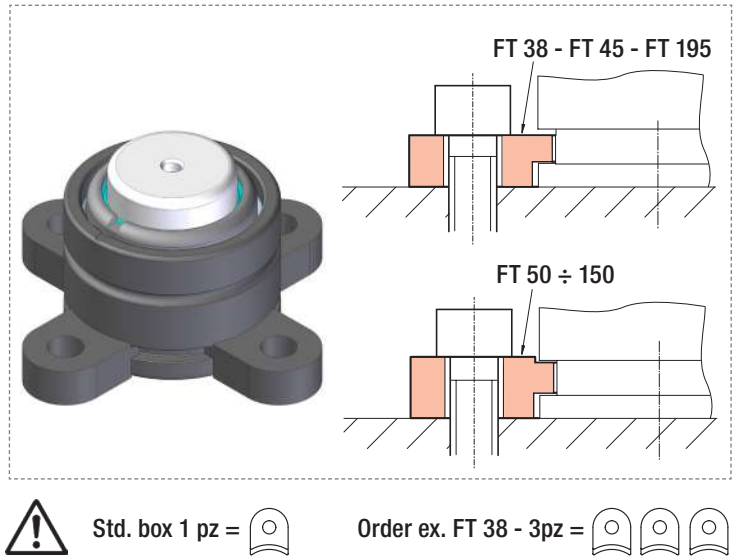
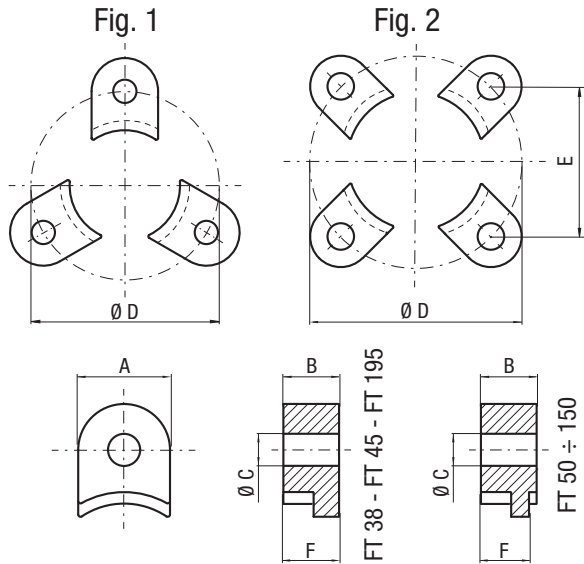

CODE	Reference to standards	A		B		C		Ø D		E		F		Rif. Fig
		mm	inch	mm	inch	mm	inch	mm	inch	mm	inch	mm	inch	
FT 38	0	20	0.79	7	0.28	7	0.28	56,6	2.23	-	-	7	0.28	Fig. 1
FT 45	0	25	0.98	7	0.28	9	0.35	70,7	2.78	-	-	7	0.28	
FT 50	0	30	1.18	14,2	0.56	13	0.51	80	3.15	-	-	13	0.51	
FT 63	0	30	1.18	14,2	0.56	13	0.51	92	3.62	65	2.56	13	0.51	Fig. 2
FT 75	0	30	1.18	14,2	0.56	13	0.51	104	4.09	73,5	2.89	13	0.51	
FT 95	0	40	1.57	14,2	0.56	17	0.67	130	5.12	92	3.62	13	0.51	
FT 120	0	50	1.97	14,2	0.56	17	0.67	155	6.1	109,5	4.31	13	0.51	
FT 150	0	50	1.97	14,2	0.56	21	0.83	195	7.68	138	5.43	13	0.51	
FT 195	0	58	2.28	16	0.63	21	0.83	240	9.45	169	6.65	16	0.63	

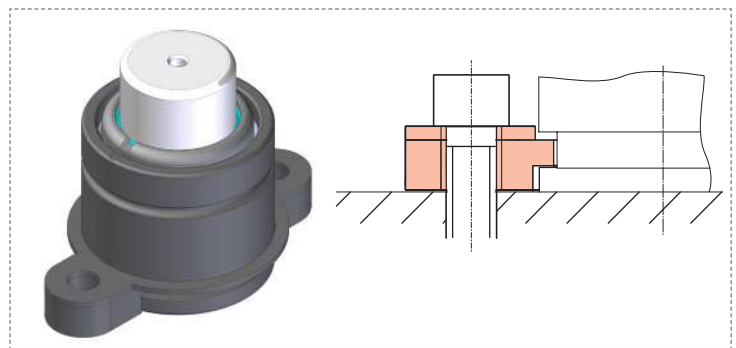
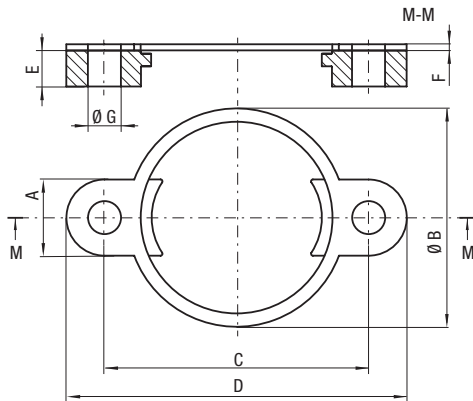

CODE	Reference to standards	A		Ø B		C		D		E		F		Ø G	
		mm	inch	mm	inch	mm	inch	mm	inch	mm	inch	mm	inch	mm	inch
FTP 38	0	20	0.79	48	1.89	56.6	2.23	76.6	3.02	7	0.28	2,5	0.10	7	0.28
FTP 45	0	25	0.98	56	2.20	70.7	2.78	95.7	3.77	7	0.28	2,5	0.10	9	0.35
FTP 50	0	30	1.18	61	2.40	80	3.15	110	4.33	14,2	0.56	2,5	0.10	13	0.51
FTP 63	0	30	1.18	73	2.87	92	3.62	122	4.80	14,2	0.56	2,5	0.10	13	0.51
FTP 75	0	30	1.18	86	3.39	104	4.09	134	5.28	14,2	0.56	2,5	0.10	13	0.51
FTP 95	0	40	1.57	106	4.17	130	5.12	170	6.69	14,2	0.56	2,5	0.10	17	0.67
FTP 120	0	50	1.97	131	5.16	155	6.10	205	8.07	14,2	0.56	2,5	0.10	17	0.67
FTP 150	0	50	1.97	170	6.69	195	7.68	245	9.65	14,2	0.56	2,5	0.10	21	0.83

FSA - FSF

ISO	VDI	BMW	General Motors
-----	-----	-----	----------------

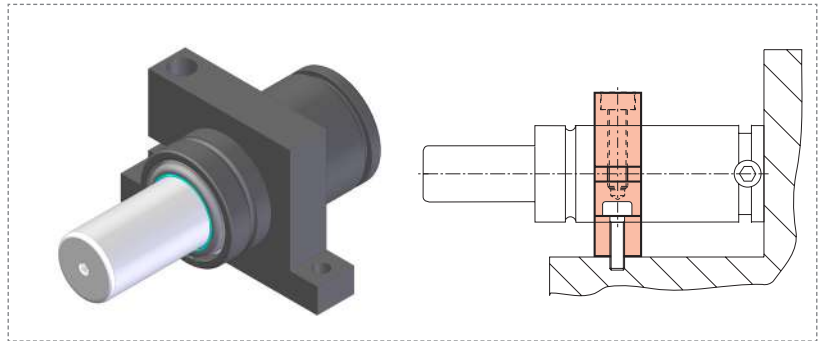
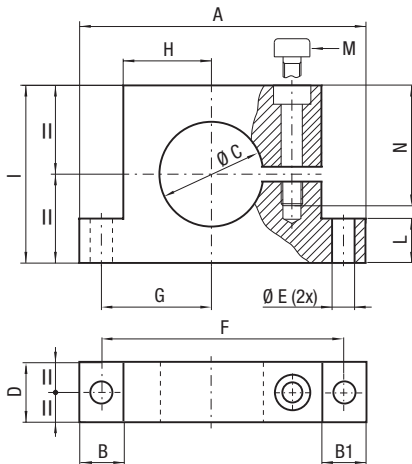

CODE	Reference to standards	A		B		B1		Ø C		D		Ø E		F		G		H		I		L		M	N	
		mm	inch	mm	inch	mm	inch	mm	inch	mm	inch	mm	inch	mm	inch	mm	inch	mm	inch	mm	inch	mm	inch		mm	inch
FSA 32	1-2-3-13-19	90	3.54	18	0.71	18	0.71	32	1.26	20	0.79	9	0.35	72	2.83	31	1.22	22	0.87	45	1.77	15	0.59	M8	39	1.54
FSF 32	12	90	3.54	18	0.71	18	0.71	32	1.26	30	1.18	8,5	0.33	72	2.83	31	1.22	22	0.87	45	1.77	15	0.59	M8	40	1.57
FSA 38	1-2-3-13-19	95	3.74	18	0.71	18	0.71	38	1.50	20	0.79	9	0.35	77	3.03	34	1.34	25	0.98	55	2.17	15	0.59	M8	45	1.77
FSF 38	12	95	3.74	17	0.67	19	0.75	38	1.50	30	1.18	8,5	0.33	77	3.03	34	1.34	25	0.98	55	2.17	15	0.59	M8	46	1.81
FSA 45	1-2-3-13-19	100	3.94	18	0.71	18	0.71	45	1.77	20	0.79	9	0.35	82	3.23	37	1.46	28	1.10	60	2.36	15	0.59	M8	45	1.77
FSF 45	12	100	3.94	18	0.71	18	0.71	45	1.77	30	1.18	8,5	0.33	82	3.23	37	1.46	28	1.10	60	2.36	15	0.59	M8	52	2.05
FSA 50	1-2-3-13-19	130	5.12	20	0.79	20	0.79	50	1.97	30	1.18	9	0.35	110	4.33	50	1.97	40	1.57	80	3.15	20	0.79	M8	55	2.17
FSA 75	1-2-3-13-19	160	6.30	22,5	0.89	22,5	0.89	75	2.95	30	1.18	11	0.43	137	5.39	63,5	2.50	52,5	2.07	105	4.13	20	0.79	M10	80	3.15
FSA 95	1-2-3-13-19	195	7.68	25	0.98	25	0.98	95	3.74	30	1.18	13,5	0.53	170	6.69	80	3.15	67,5	2.66	125	4.92	20	0.79	M12	99,5	3.92
FSA 120	1-2-3-13-19	220	8.66	27,5	1.08	27,5	1.08	120	4.72	30	1.18	13,5	0.53	195	7.68	92,5	3.64	77,5	3.05	148	5.83	20	0.79	M12	106	4.17
FSA 150	1-2-3-13-19	260	10.24	30	1.18	30	1.18	150	5.91	30	1.18	13,5	0.53	230	9.06	110	4.33	95	3.74	200	7.87	20	0.79	M12	138	5.43

FSB - FSC - FSD

VDI	BMW	Ford	Mercedes Benz
-----	-----	------	---------------

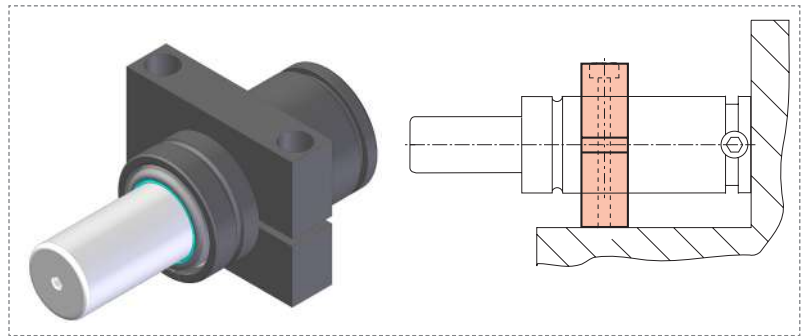
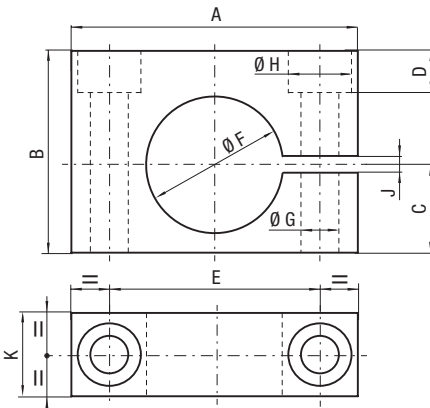

CODE	Reference to standards	A		B		C		D		E		Ø F		Ø G		Ø H		J		K	
		mm	inch	mm	inch	mm	inch	mm	inch	mm	inch	mm	inch	mm	inch	mm	inch	mm	inch	mm	inch
FSB 32	6	80	3.15	63	2.48	38,5	1.52	18	0.71	56	2.20	32	1.26	10,5	0.41	17	0.67	6	0.24	25	0.98
FSD 32	2-3-12-18-21-27	68	2.68	48	1.89	20,9	0.82	10	0.39	50	1.97	32,5	1.28	9	0.35	15	0.59	4	0.16	20	0.79
FSD 38	2-3-12-18-21-27	74	2.91	54	2.13	23,9	0.94	16	0.63	54	2.13	38,5	1.52	9	0.35	15	0.59	4	0.16	20	0.79
FSD 45	2-3-12-18-21-27	80	3.15	60	2.36	27,5	1.08	22	0.87	60	2.36	45,5	1.79	9	0.35	15	0.59	4	0.16	20	0.79
FSD 50	2-3-4-12-18-21-27	90	3.54	70	2.76	30	1.18	25	0.98	68	2.68	50,5	1.99	11	0.43	18	0.71	5	0.20	30	1.18
FSC 63	0	105	4.13	80	3.15	40	1.57	11	0.43	80	3.15	63	2.48	10,5	0.41	17	0.67	10	0.39	30	1.18
FSD 63	2-18-21-27	108	4.25	82	3.23	36,5	1.44	27	1.06	84	3.31	63,5	2.50	11	0.43	18	0.71	5	0.20	30	1.18
FSD 75	2-3-4-12-18-21-27	125	4.92	94	3.70	42	1.65	32	1.26	100	3.94	75,5	2.97	13,5	0.53	20	0.79	5	0.20	30	1.18
FSD 95	2-3-4-12-18-21-27	140	5.51	115	4.53	52,5	2.07	33	1.30	115	4.53	95,5	3.76	13,5	0.53	20	0.79	5	0.20	30	1.18
FSD 120	2-3-12-18-21-27	170	6.69	140	5.51	65	2.56	58	2.28	145	5.71	120,5	4.74	13,5	0.53	20	0.79	7	0.28	30	1.18
FSD 150	2-3-12-18-21-27	200	7.87	170	6.69	80	3.15	68	2.68	175	6.89	150,5	5.93	13,5	0.53	20	0.79	7	0.28	30	1.18

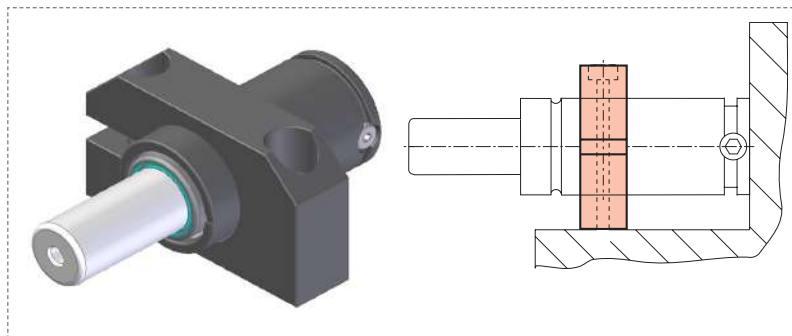
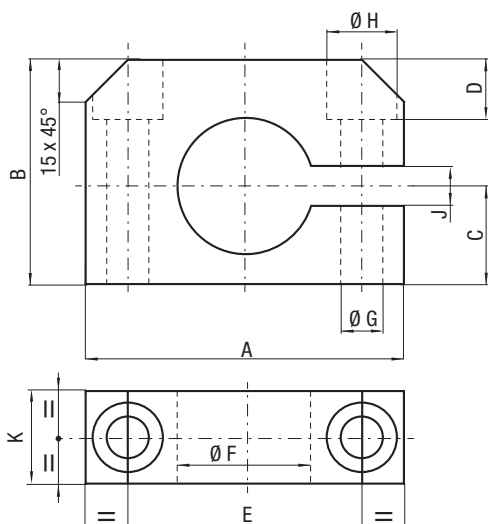

CODE	Reference to standards	A		B		C		D		E		Ø F		Ø G		Ø H		J		K	
		mm	inch	mm	inch	mm	inch	mm	inch	mm	inch	mm	inch	mm	inch	mm	inch	mm	inch	mm	inch
FSE45	0	100	3.94	60	2.36	30	1.18	20	0.79	70	2.76	45,3	1.78	11	0.43	18	0.71	10	0.39	25	0.98

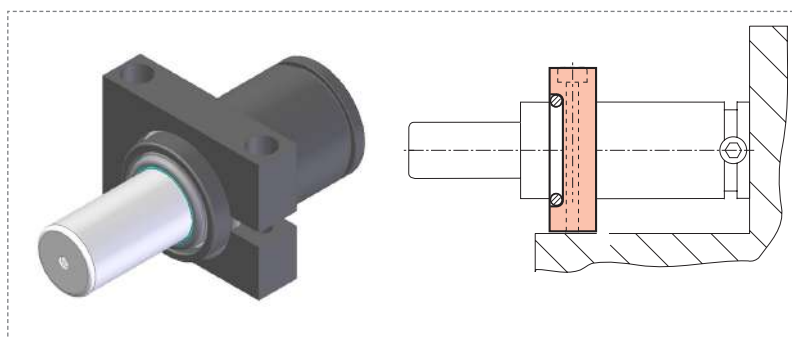
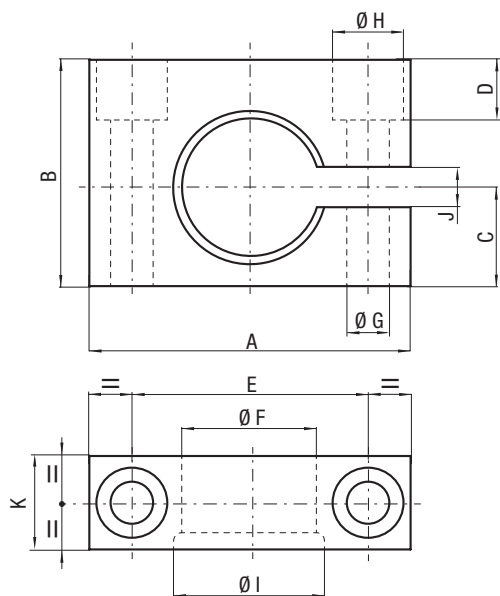

CODE	Reference to standards	A		B		C		D		E		Ø F		Ø G		Ø H		Ø I		J		K	
		mm	inch	mm	inch	mm	inch	mm	inch	mm	inch	mm	inch	mm	inch	mm	inch	mm	inch	mm	inch	mm	inch
FSE50	11	90	3.54	70	2.76	30	1.18	25	0.98	68	2.68	50,3	1.98	11	0.43	18	0.71	54,1	2.13	10	0.39	30	1.18
FSE75	11	125	4.92	94	3.70	42	1.65	19	0.75	100	3.94	75,3	2.96	13	0.51	20	0.79	80,1	3.15	10	0.39	30	1.18
FSE95	11	140	5.51	115	4.53	52,5	2.07	40	1.57	115	4.53	95,3	3.75	13	0.51	20	0.79	100,1	3.94	10	0.39	30	1.18

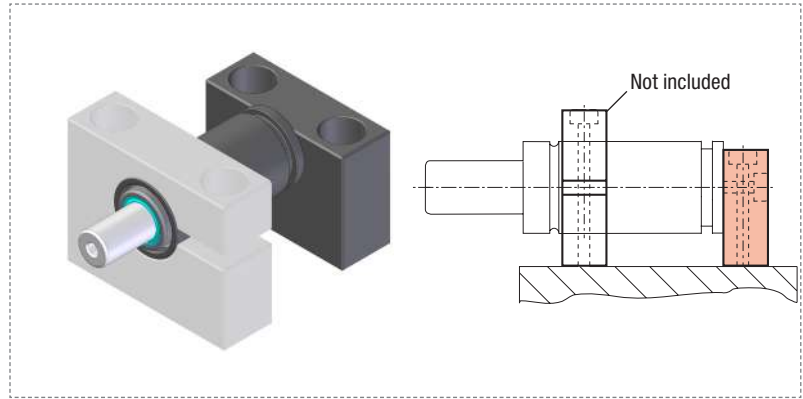
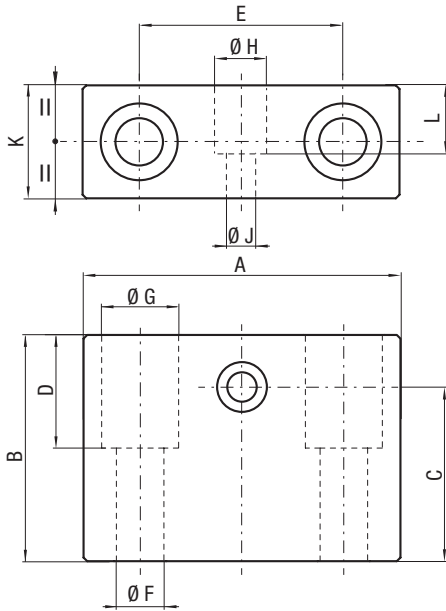

CODE	Reference to standards	A		B		C		D		E		Ø F		Ø G		Ø H		Ø J		L		K	
		mm	inch	mm	inch	mm	inch	mm	inch	mm	inch	mm	inch	mm	inch	mm	inch	mm	inch	mm	inch	mm	inch
R32A	5	70	2.76	50	1.97	38,5	1.52	25	0.98	45	1.77	10,5	0.41	17	0.67	11	0.43	6,5	0.26	15	0.59	25	0.98

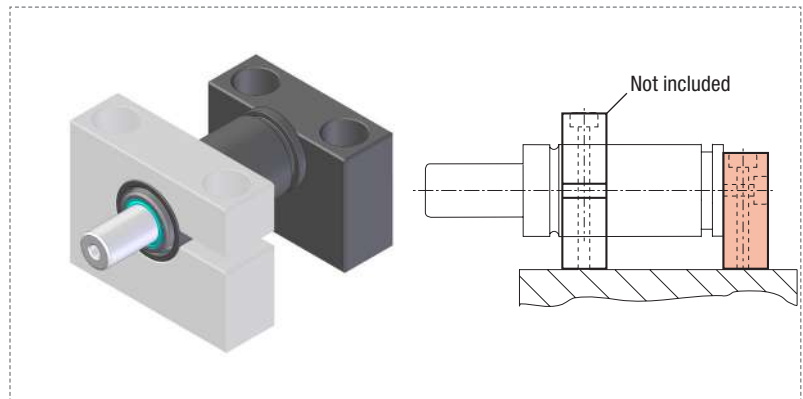
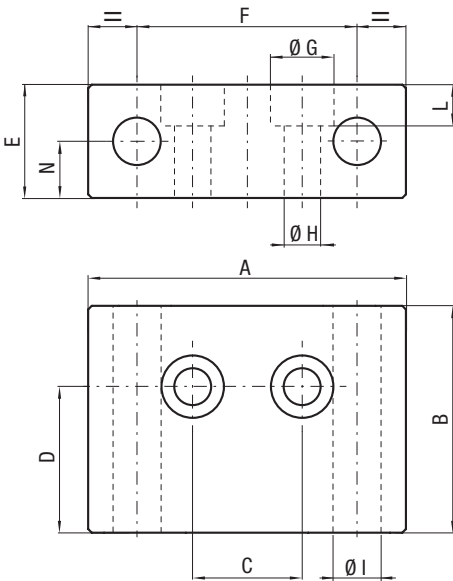

CODE	Reference to standards	A		B		C		D		E		F		Ø G		Ø H		L		Ø I		N	
		mm	inch	mm	inch	mm	inch	mm	inch	mm	inch	mm	inch	mm	inch	mm	inch	mm	inch	mm	inch	mm	inch
R38A	4	60	2.36	38	1.50	18	0.71	23,9	0.94	28	1.10	40	1.57	14	0.55	9	0.35	10	0.39	9	0.35	12	0.47
R50A	11	65	2.56	45	1.77	20	0.79	30	1.18	28	1.10	44	1.73	14	0.55	9	0.35	10	0.39	11	0.43	13	0.51
R75A	11	80	3.15	45	1.77	28,3	1.11	27,8	1.09	28	1.10	57	2.24	14	0.55	9	0.35	10	0.39	14	0.55	12	0.47
R95A	11	95	3.74	45	1.77	42,4	1.67	31,2	1.23	28	1.10	70	2.76	14	0.55	9	0.35	10	0.39	14	0.55	15	0.59

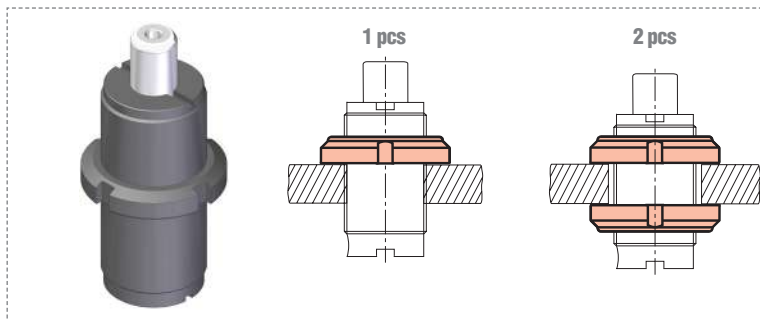
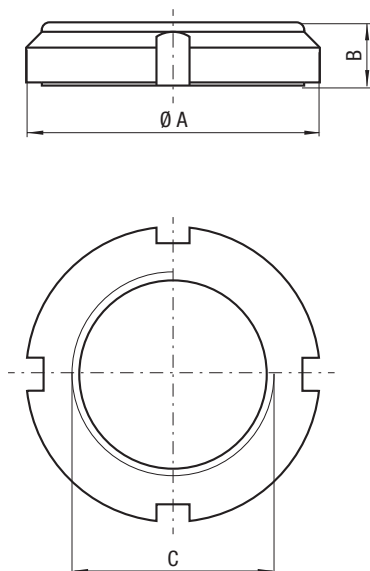

CODE (1 pcs)	Reference to standards	Ø A		B		C
		mm	inch	mm	inch	
GM 38	0	53	2.09	12	0.47	M 38 X 1,5
⚠ GM 45	0	62	2.44	12,3	0.48	M 45 X 1,5
⚠ GM 50	0	68	2.68	12,9	0.51	M 50 X 1,5

⚠ Phasing out

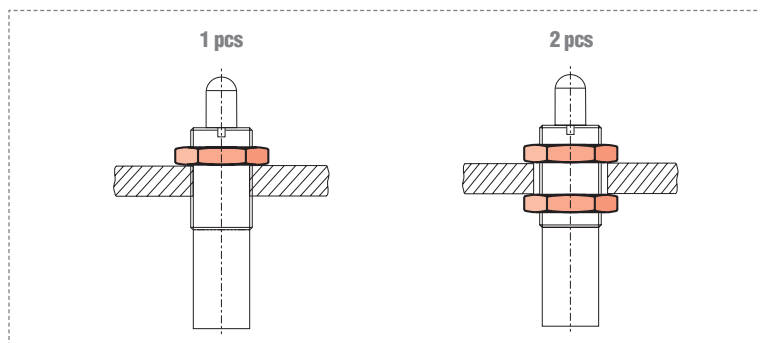
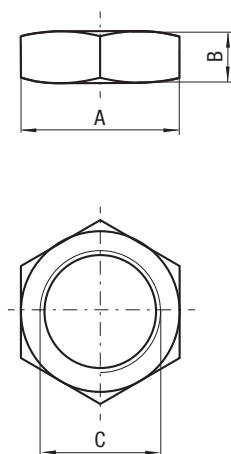
DM - DI

CODE (1 pcs)	Reference to standards	A	B		C
			mm	inch	
DM 16	0-28	S24	8	0.31	M 16 x 1,5
39DM16X2A	0	S24	8	0.31	M 16 x 2
39DI5/8-11A	0	S26	9	0.36	5/8" - 11 UNC
DM 24	0-28	S36	10	0.39	M 24 x 1,5
DI 1" - 8	0	S38	14	0.55	1" - 8



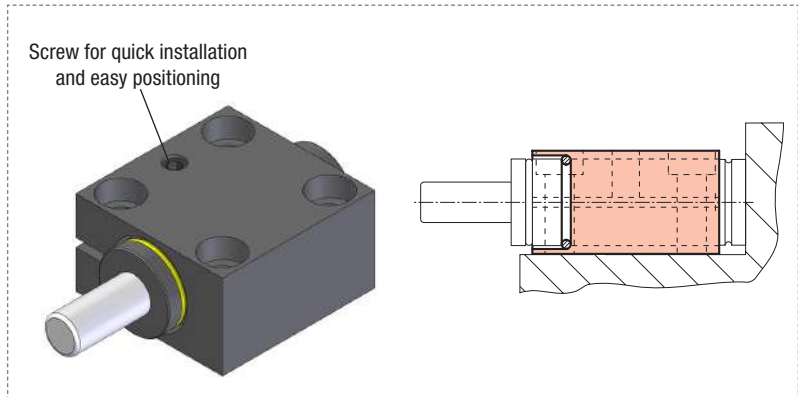
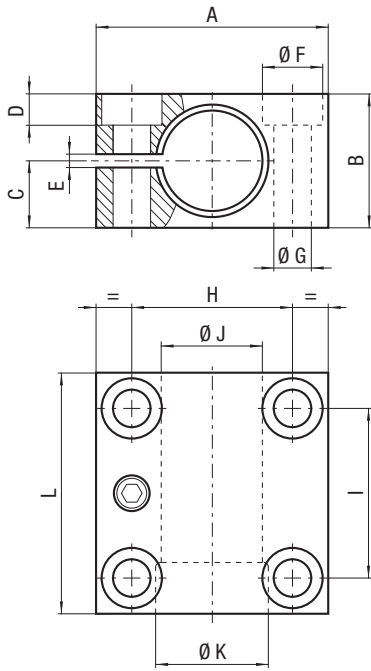

CODE	Reference to standards	A		B		C		D		E		Ø F		Ø G		H		I		J		K		L	
		mm	inch	mm	inch	mm	inch	mm	inch	mm	inch	mm	inch	mm	inch	mm	inch	mm	inch	mm	inch	mm	inch	mm	inch
FSG25	0	52	2.05	30	1.18	15	0.59	7	0.28	3	0.12	13,5	0.53	8,4	0.33	36	1.42	38	1.5	25,2	1.03	27	1.06	54	2.13

easy

MANIFOLD

since 1997

easy
since 1997 MANIFOLD

the easy way
to link gas springs through plate



OSAS
Over Stroke
Active Safety



USAS
Uncontrolled Speed
Active Safety



OPAS
Over Pressure
Active Safety



SKUDO
Active Protection
from Contaminants

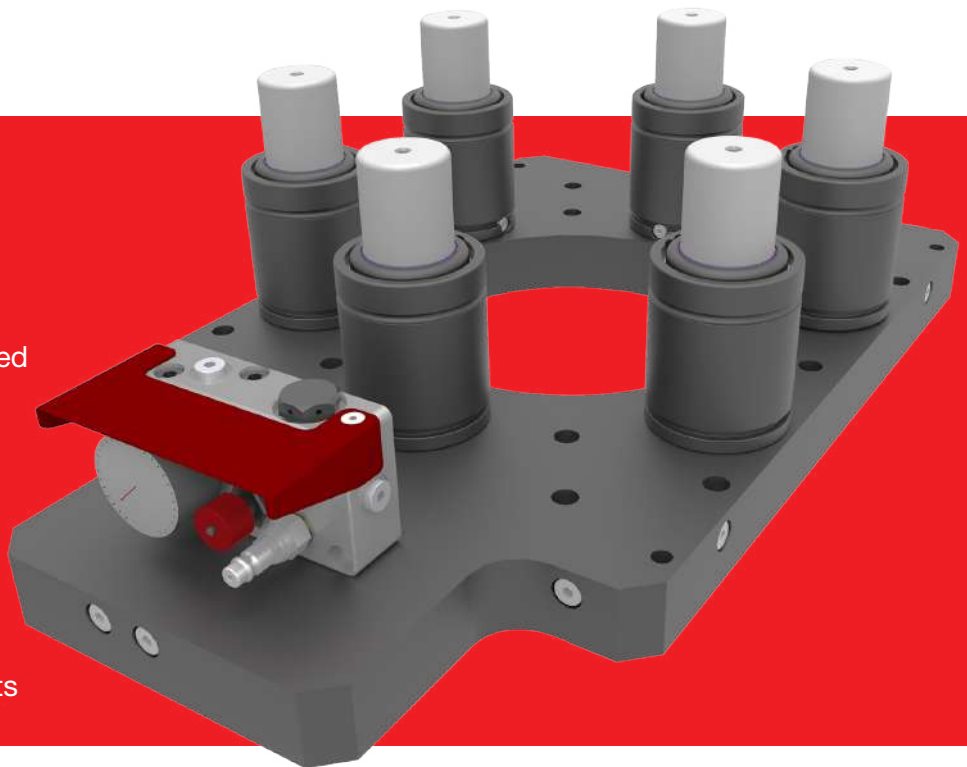

easy
MANIFOLD

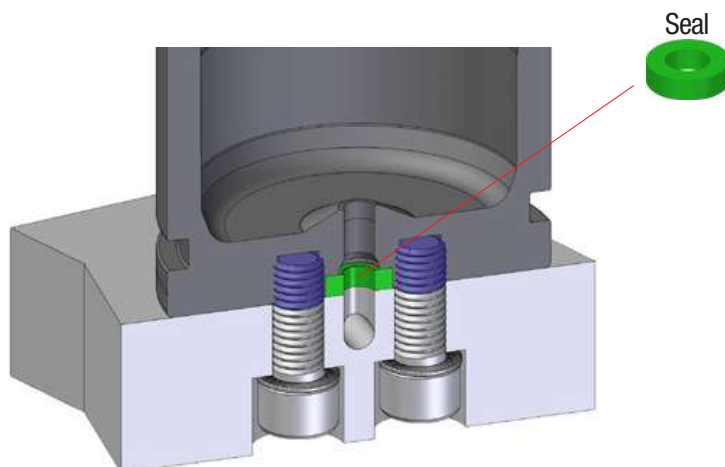

IT CARATTERISTICHE:

- Vantaggiosa alternativa ai tradizionali e costosi cilindri Manifold.
- Grande varietà di combinazioni con l'uso di cilindri standard.
- Totale eliminazione di tubi e raccordi.
- Pressione uniforme nel sistema.
- Facile manutenzione, uguale ai cilindri standard.
- Piastre di collegamento realizzabili direttamente dagli utilizzatori.
- Massima flessibilità di realizzazione degli impianti.
- Nessuna richiesta di utensili speciali per l'installazione.
- **Special Springs è in grado di fornire le piastre/cuscino su specifiche del cliente, collaudate e pronte per l'installazione.**

EN CHARACTERISTICS:

- An advantageous alternative to conventional and expensive Manifold cylinders.
- Large variety of combinations with the use of standard gas springs.
- Total elimination of hoses and connections.
- Balanced pressure in the system.
- Easy maintenance, the same as standard gas springs.
- Connection plates can be made directly by users.
- Maximum flexibility in creation of systems.
- No special tools required for installation.
- **Special Springs can supply the plates/cushion to customer specifications, tested and ready for installation.**

FR CARACTERISTIQUES:

- Une alternative avantageuse aux traditionnels et coûteux cylindres Manifold.
- Une grande variété de combinaisons avec l'emploi de cylindres standard.
- L'élimination totale de tuyaux et raccords.
- Pression uniforme dans le système.
- Entretien facile, comme celui des cylindres standard.
- Plaques de liaison réalisables directement par les utilisateurs.
- Très grande souplesse de réalisation des installations.
- Aucun besoin d'outils spéciaux pour l'installation.
- **Special Springs est en mesure de fournir les plaques/coussin sur spécifications du client, testées et prêtes à être installées.**

ES CARACTERÍSTICAS:

- Ventajosa alternativa a los tradicionales y costosos cilindros Manifold.
- Gran variedad de combinaciones con el uso de cilindros (autónomos) estándar.
- Total eliminación de tubos y racores.
- Presión uniforme en el sistema.
- Fácil mantenimiento, igual a la de los cilindros (autónomos) estándar.
- Placas de conexión producibles directamente por el usuario.
- Máxima flexibilidad de diseño de los sistemas de conexión.
- No se requiere ninguna herramienta especial para la instalación.
- **Special Springs puede proporcionar las placas/cojines según especificaciones del cliente, comprobados y listos para la instalación.**

DE EIGENSCHAFTEN

- Preisgünstige Alternative zu herkömmlichen Manifold-Gasdruckfedern.
- Große Auswahl an Einsatzkombinationen durch Verwendung von Standardzylindern.
- Keine Verwendung von Schläuchen und Anschlüssen.
- Gleichmäßiger Druck im System.
- Wartungsfreundlich.
- Verbundplatten können vom Kunden selbst gefertigt werden.
- Hohe Flexibilität bei den Anwendungen.
- Montage ohne Sonderwerkzeuge.
- **Platten können von Special Springs gefertigt, getestet und vormontiert geliefert werden.**

PT CARACTERÍSTICAS:

- Vantajosa alternativa aos tradicionais e caros cilindros Manifold.
- Grande variedade de combinações com uso de cilindros standard.
- Total eliminação de tubos e junções.
- Pressão uniforme em o sistema.
- Fácil manutenção, igual a dos cilindros standard.
- Chapas de conexão que podem ser realizadas diretamente pelos usuários.
- Máxima flexibilidade de realização das instalações.
- Não é necessário utilizar nenhum tipo de utensílio especial para a instalação.
- **Special Springs pode fornecer chapas/coxim conforme exigência do cliente, testadas e verificadas prontas para a instalação.**

Design recommendations

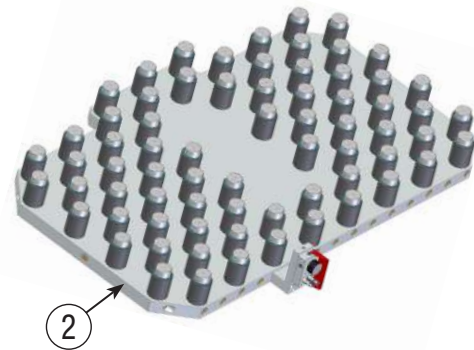
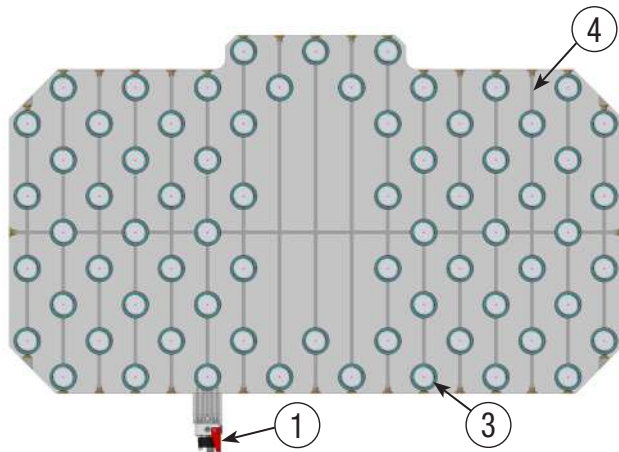

IT Per una facile progettazione e per ridurre i costi di produzione seguire le linee guida di cui sotto

- ① • Per collegare il pannello usare, se possibile, i canali del gas esistenti.
- ① • In alternativa collegare il pannello con tubi e raccordi.
- ② • Resilienza materiale piastra alla temperatura minima di utilizzo $\geq 27\text{J}$.
- ② • Allungamento a rottura del materiale piastra $\geq 14\%$.
- ③ • Evitare interferenza tra i fori di fissaggio dei cilindri e i canali del gas.
- ③ • Selezionare cilindri con corse maggiori per aumentare il volume del sistema.
- ④ • Realizzare canali passanti e pulire adeguatamente.
- ④ • Evitare canali ciechi.

EN For easier design and manufacturing cost-saving follow the guide lines below

- ① • When possible, use the existing gas ports to link the panel.
- ① • Alternatively, link the panel by using hoses and connections.
- ② • Resilience of the plate material at minimum operating temperature $\geq 27\text{J}$.
- ② • Elongation at break of plate material $\geq 14\%$.
- ③ • Avoid interference between the gas spring's fixing holes and the gas ports.
- ③ • Select gas springs with higher stroke to increase the volume of the system.
- ④ • Machine thru-holes and adequately clear the ports.
- ④ • Avoid blind channels.

DE Für eine leichter von staten gehende Entwicklung und um Produktionskosten zu sparen, befolgen Sie die Richtlinien unten.

- ① • Die Kontrollarmatur, wenn möglich, an den vorhandenen Tieflochbohrungen anbringen.
- ① • Alternativ kann die Druckkontrollarmatur mit Schlauchkomponenten angeschlossen werden.
- ② • Zähigkeit des Plattenmaterials bei minimaler Betriebstemperatur $\geq 27\text{J}$.
- ② • Bruchdehnung des Plattenmaterials $\geq 14\%$.
- ③ • Überschneidungen zwischen der Lage der Zylinder-Befestigungslöchern und den Gaskanälen sind zu vermeiden.
- ③ • Um das Volumen des Systems zu vergrößern, wählen Sie Gasdruckfedern mit dem nächst größeren Hub.
- ④ • Die Durchgangsbohrungen sauber fertigen
- ④ • Blinde Kanäle vermeiden.

FR Pour une conception plus facile et de l'épargne des coûts de fabrications suivez les instructions ci-dessous

- ① • Pour relier le panneau utiliser, si possible, les canaux du gaz existents.
- ① • Alternativement, joindre le panneau en utilisant des tubes et des raccords.
- ② • Résilience du matériau de la plaque à la température minimale de fonctionnement $\geq 27\text{J}$.
- ② • Allongement à la rupture du matériau de la plaque $\geq 14\%$.
- ③ • Eviter l'interférence entre les trous de fixation des ressorts et les canaux du gaz.
- ③ • Sélectionner des ressorts avec des courses majeures pour augmenter le volume du système.
- ④ • Réaliser des trous débouchants et nettoyez correctement.
- ④ • Eviter les trous sans issue.

ES Para facilitar el diseño y poder reducir costes de producción se recomienda seguir las instrucciones indicadas a continuación

- ① • En la medida de lo posible usar los canales de gas existentes para conectar el panel.
- ① • Como alternativa, conectar el panel con tuberías y racores.
- ② • Resiliencia del material de la placa a la temperatura mínima de uso $\geq 27\text{J}$.
- ② • Alargamiento a la rotura del material de la placa $\geq 14\%$.
- ③ • Evitar la interferencia entre los orificios de fijación de los cilindros y los canales de gas.
- ③ • Seleccionar cilindros con mayores carreras para aumentar el volumen del sistema.
- ④ • Mecanizar agujeros pasantes en la placa y limpiar adecuadamente.
- ④ • Evitar agujeros ciegos.

PT Para facilitar o desenho e economizar custos de produção seguir as orientações abaixo mencionados

- ① • Para ligar o painel, se possível, usar os canais de gás existentes.
- ① • Em alternativa conecte o painel com tubos e acessórios.
- ② • Placa com resistência mínima a temperatura mínima de $> 27\text{J}$.
- ② • Alongamento de ruptura do material da placa $\geq 14\%$.
- ③ • Evitar a interferência entre os orifícios de fixação dos cilindros e os canais de gás.
- ③ • Escolher os cilindros com curso mais grande para aumentar o volume do sistema.
- ④ • Realizar orifícios de passagem par toda a placa e bem limpar.
- ④ • Evitar orifícios sem saída.

E - ED - EV versions ■

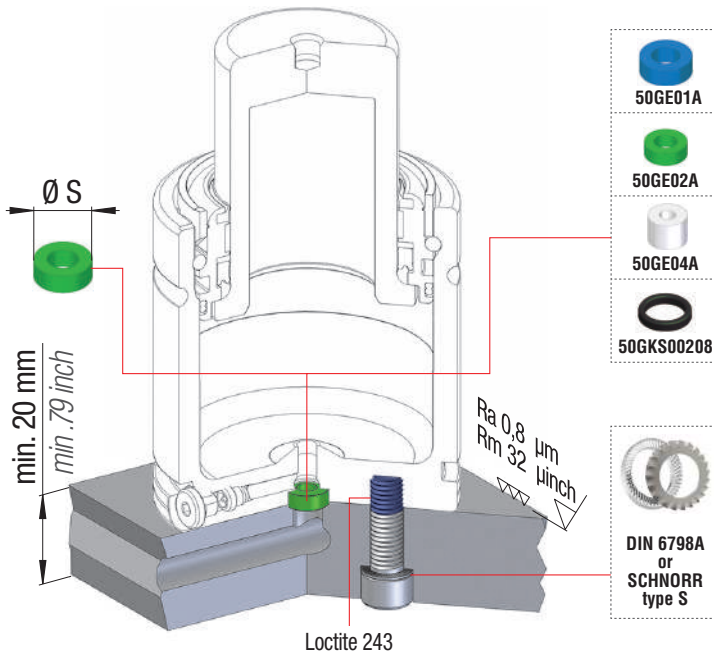

Example A > D : Thread size M8 x 13 (13 > 8)

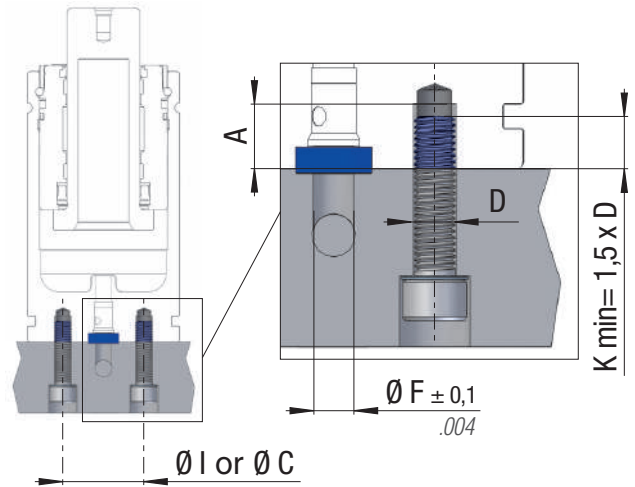

Example A ≤ D : Thread size M8 x 6 (6 ≤ 8)

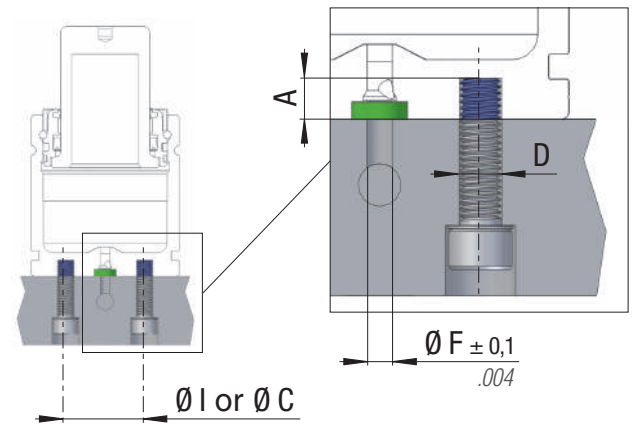

$\varnothing I$ or $\varnothing C$	D	A
Interasse fissaggio Fixing c.t.c. distance Mittensabstand Entraxe Distancia centros Distância eixos	Dimensione viti Screw dimension Schraubengröße Dimension vis Dimensión tornillos Dimensão parafusos	Profondità filetti Thread depth Gewindetiefe Profondeur filet Profundidad rosca Profundidade rosca
K min	$\varnothing F$	$\varnothing S$
Minimo impegno viti Minimum thread engagement Mindest-Einschraublänge Longueur minimum à visser Min Longitud roscada mínima Comprimento mínimo roscado	\varnothing Foro piastra - cilindro \varnothing Plate - Gas spring hole \varnothing Platten - Zylinder Loch \varnothing Trou plaque - cylindre \varnothing Alojamiento Placa - Cilindro \varnothing Furo Placa - Cilindro	\varnothing Guarnizione piastra - cilindro \varnothing Plate - Gas spring seal \varnothing Platten - Zylinder Dichtung \varnothing Joint plaque - cylindre \varnothing Retén Placa - Cilindro \varnothing Junta Placa - Cilindro

MOUNTING HOLES		
α	γ	
β	δ	ε

Diagrams showing different mounting hole configurations (α, γ, β, δ, ε) with dimensions $\varnothing I$ and $\varnothing C$ and a 45° angle.

NOTE	
1	Modello con corpo liscio senza cave di fissaggio Model with straight body without fixing grooves Model mit flachem Körper ohne Befestigungsnuten Modèle avec corps lisse sans encoches de fixation Modelo con cuerpo liso sin ranuras para la fijación Modelo com corpo liso sem ranhuras de fixação
2	Modello con corpo senza foro di caricamento laterale Model with body without side charging port Model mit Körper ohne Nebenladeloeh Modèle avec corps sans trou de charge latéral Modelo con cuerpo sin agujero lateral de carga Modelo com corpo sem orificio de carregamen

IT Corse e ingombri uguali al cilindro autonomo
EN Strokes and sizes same to selfcontained gas spring
DE Hübe und Abmessungen sind identisch mit den autonomen Gdf

FR Courses et ecombremet égaux à ceux du Cylindre autonome
ES Carreras y dimensiones iguales a las del cilindro autónomo
PT Cursos e dimensões iguais às do cilindro autónomo

Series	Model	Rev. code	Version	Mounting holes	Thread size D x A	Ø I		Ø C		Ø F		Ø S		Seal code	Note	Cover code > see pag 257	Maintenance kit
						mm	inch	mm	inch	mm	inch	mm	inch				
RV	350	B	E	α	M6 x 6	20	0.79	-	5	0.20	7,5	0.30	50GE04A	1+2	39TE010A	39BMRV00350CE	
	500	B	E	β	M6 x 6	20	0.79	25	0.98	5	0.20	7,5	0.30	50GE04A	1+2	39TE001A	39BMRV00500CE
	750	B	E	γ	M8 x 6	26	1.02	-	5	0.20	11	0.43	50GE02A	1+2	39TE002A	39BMRV00750CE	
	1000	B	E	γ	M8 x 6	34	1.34	-	5	0.20	11	0.43	50GE02A	1+2	39TE003A	39BMRV01000CE	
	1200	B	E	γ	M8 x 6	34	1.34	-	5	0.20	11	0.43	50GE02A	1+2	39TE003A	39BMRV01000CE	
	1500	B	E	γ	M8 x 6	34	1.34	-	5	0.20	11	0.43	50GE02A	1+2	39TE009A	39BMRV01500CE	
	2400	B	E	γ	M8 x 6	40	1.57	-	5	0.20	11	0.43	50GE02A	-	39TE004A	39BMRV02400DE	
	4200	B	E	γ	M8 x 12	60	2.36	-	8	0.31	15	0.59	50GE01A	-	39TE005A	39BMRV04200CE	
	6600	B	E	γ	M10 x 12	80	3.15	-	8	0.31	15	0.59	50GE01A	-	39TE006A	39BMRV06600CE	
	9500	B	E	γ	M10 x 13	100	3.94	-	8	0.31	15	0.59	50GE01A	-	39TE007A	39BMRV09500CE	
	12000	B	E	γ	M10 x 13	100	3.94	-	8	0.31	15	0.59	50GE01A	-	39TE007A	39BMRV12000AE	
	20000	B	E	γ	M12 x 16	120	4.72	-	8	0.31	15	0.59	50GE01A	-	39TE008A	39BMRV20000AE	
	750	B	EV	α	M8 x 6	20	0.79	-	5	0.20	11	0.43	50GE02A	-	39TE011A	39BMRV00750CE	
	1000	B	EV	α	M8 x 6	20	0.79	-	5	0.20	11	0.43	50GE02A	-	39TE011A	39BMRV01000CE	
	1200	B	EV	α	M8 x 6	20	0.79	-	5	0.20	11	0.43	50GE02A	-	39TE011A	39BMRV01000CE	
	1500	C	EV	ε	M8 x 6	20	0.79	40	1.57	5	0.20	11	0.43	50GE02A	-	39TE011A	39BMRV01500CE
RS	350	B	E	α	M6 x 6	20	0.79	-	5	0.20	7,5	0.30	50GE04A	1+2	39TE010A	39BMRV00350CE	
	500	B	E	β	M6 x 6	20	0.79	25	0.98	5	0.20	7,5	0.30	50GE04A	1+2	39TE001A	39BMRV00500CE
	750	B	E	γ	M8 x 6	26	1.02	-	5	0.20	11	0.43	50GE02A	1+2	39TE002A	39BMRV00750CE	
	1000	B	E	γ	M8 x 6	34	1.34	-	5	0.20	11	0.43	50GE02A	1+2	39TE003A	39BMRV01000CE	
	1200	B	E	γ	M8 x 6	34	1.34	-	5	0.20	11	0.43	50GE02A	1+2	39TE003A	39BMRV01000CE	
	1500	B	E	γ	M8 x 6	34	1.34	-	5	0.20	11	0.43	50GE02A	1+2	39TE009A	39BMRV01500CE	
	2400	B	E	γ	M8 x 6	40	1.57	-	5	0.20	11	0.43	50GE02A	-	39TE004A	39BMRV02400DE	
	4200	B	E	γ	M8 x 12	60	2.36	-	8	0.31	15	0.59	50GE01A	-	39TE005A	39BMRV04200CE	
	6600	B	E	γ	M10 x 12	80	3.15	-	8	0.31	15	0.59	50GE01A	-	39TE006A	39BMRV06600CE	
	9500	B	E	γ	M10 x 13	100	3.94	-	8	0.31	15	0.59	50GE01A	-	39TE007A	39BMRV09500CE	
RF	750	B	E	γ	M8 x 13	26	1.02	-	5	0.20	11	0.43	50GE02A	1+2	39TE002A	39BMRV00750CE	
	2400	B	E	γ	M8 x 13	40	1.57	-	8	0.31	15	0.59	50GE01A	-	39TE004A	39BMRV02400DE	
RG	2400	B	E	γ	M8 x 16	40	1.57	-	8	0.31	15	0.59	50GE01A	-	39TE004A	39BMRV02400DE	
	4200	B	E	γ	M8 x 16	60	2.36	-	8	0.31	15	0.59	50GE01A	-	39TE005A	39BMRV04200CE	
	6600	B	E	γ	M10 x 16	80	3.15	-	8	0.31	15	0.59	50GE01A	-	39TE006A	39BMRV06600CE	
RT	2400	B	E	γ	M12 x 16	53,9	2.12	-	8	0.31	15	0.59	50GE01A	-	39TE004A	39BMRV02400DE	
	4200	B	E	γ	M12 x 16	76,2	3.00	-	8	0.31	15	0.59	50GE01A	-	39TE005A	39BMRV04200CE	
	6600	B	E	γ	M12 x 16	80,8	3.18	-	8	0.31	15	0.59	50GE01A	-	39TE006A	39BMRV06600CE	
	9500	B	E	γ	M12 x 16	100	3.94	-	8	0.31	15	0.59	50GE01A	-	39TE007A	39BMRV09500CE	
S	750	B	E	α	M8 x 13	20	0.79	-	5	0.20	11	0.43	50GE02A	-	39TE011A	39BMS00750BE	
	1500	B	E	γ	M8 x 13	40	1.57	-	8	0.31	15	0.59	50GE01A	-	39TE004A	39BMS01500BE	
	3000	B	E	γ	M8 x 13	60	2.36	-	8	0.31	15	0.59	50GE01A	-	39TE005A	39BMS03000BE	

Series	Model	Rev. code	Version	Mounting holes	Thread size D x A	Ø I		Ø C		Ø F		Ø S		Seal code	Note	Cover code > see pag 257	Maintenance kit
						mm	inch	mm	inch	mm	inch	mm	inch				
SC	150	E	E	α	M6 x 8	18	0.71	-	5	0.20	7,5	0.30	50GE04A	1+2	39TE012A	39BMSC00150EE	
	250	E	E	β	M6 x 8	18	0.71	25	0.98	5	0.20	7,5	0.30	50GE04A	1+2	39TE012A	39BMSC00250EE
	500	E	E	α	M8 x 13	20	0.79	-	5	0.20	11	0.43	50GE02A	1+2	39TE011A	39BMSC00500DE	
	750	E	E	α	M8 x 13	20	0.79	-	5	0.20	11	0.43	50GE02A	1+2	39TE011A	39BMSC00750DE	
	1500	E	E	γ	M8 x 13	40	1.57	-	8	0.31	15	0.59	50GE01A	-	39TE004A	39BMSC01500DHE	
	3000	E	E	γ	M8 x 13	60	2.36	-	8	0.31	15	0.59	50GE01A	-	39TE005A	39BMSC03000EE	
	5000	E	E	γ	M10 x 16	80	3.15	-	8	0.31	15	0.59	50GE01A	-	39TE006A	39BMSC05000EE	
	7500	E	E	γ	M10 x 16	100	3.94	-	8	0.31	15	0.59	50GE01A	-	39TE007A	39BMSC07500DHE	
	10000	E	E	γ	M12 x 16	120	4.72	-	8	0.31	15	0.59	50GE01A	-	39TE008A	39BMSC10000DE	
H	300	D	E	α	M6 x 8	18	0.71	-	5	0.20	7,5	0.30	50GE04A	1+2	39TE012A	39BMH00300BE	
	500	D	E	β	M6 x 8	18	0.71	25	0.98	5	0.20	7,5	0.30	50GE04A	1+2	39TE012A	39BMH00500BE
	700	E	E	α	M8 x 13	20	0.79	-	5	0.20	11	0.43	50GE02A	1+2	39TE011A	39BMH00700DE	
	1000	E	E	α	M8 x 13	20	0.79	-	5	0.20	11	0.43	50GE02A	1+2	39TE011A	39BMH01000DE	
	1500	D	E	ε	M8 x 13	40	1.57	20	0.79	5	0.20	11	0.43	50GE02A	-	39TE004A	39BMH01500CHE
	2400	E	E	γ	M8 x 13	40	1.57	-	8	0.31	15	0.59	50GE01A	-	39TE004A	39BMH02400DHE	
	4200	E	E	γ	M8 x 13	60	2.36	-	8	0.31	15	0.59	50GE01A	-	39TE005A	39BMH04200DHE	
	6600	E	E	γ	M10 x 16	80	3.15	-	8	0.31	15	0.59	50GE01A	-	39TE006A	39BMH06600DHE	
	9500	D	E	γ	M10 x 16	100	3.94	-	8	0.31	15	0.59	50GE01A	-	39TE007A	39BMH09500CE	
	18500	D	E	γ	M12 x 16	120	4.72	-	8	0.31	15	0.59	50GE01A	-	39TE008A	39BMH18500CE	
20000	A	E	γ	M12 x 16	120	4.72	-	8	0.31	15	0.59	50GE01A	-	39TE008A	39BMH20000AE		
HT	500 T1	B	E	β	M6 x 8	18	0.71	25	0.98	5	0.20	7,5	0.30	50GE04A	1+2	39TE012A	39BMMMGS0038BE
	700 T1	B	E	α	M8 x 13	20	0.79	-	5	0.20	11	0.43	50GE02A	1+2	39TE011A	39BMMMGS0045BE	
	1000 T1	B	E	α	M8 x 13	20	0.79	-	5	0.20	11	0.43	50GE02A	1+2	39TE011A	39BMHT01000AE	
	500 T2	B	E	β	M6 x 8	18	0.71	25	0.98	5	0.20	7,5	0.30	50GE04A	1+2	39TE012A	39BMMMGS0038BE
	700 T2	B	E	α	M8 x 13	20	0.79	-	5	0.20	11	0.43	50GE02A	1+2	39TE011A	39BMMMGS0045BE	
	1000 T2	B	E	α	M8 x 13	20	0.79	-	5	0.20	11	0.43	50GE02A	1+2	39TE011A	39BMHT01000AE	
KE	750	B	ED	α	M6 x 8	24	0.94	-	5	0.20	11	0.43	50GE02A	1+2	39TE010A	39BMKE00750BE	
	1000	B	ED	δ	M6 x 8	20	0.79	26	1.02	5	0.20	11	0.43	50GE02A	1+2	39TE001A	39BMKE01000BE
	1800	B	ED	γ	M6 x 8	26	1.02	-	5	0.20	11	0.43	50GE02A	1+2	39TE003A	39BMKE01800BE	
	3000	B	ED	γ	M8 x 8	34	1.34	-	8	0.31	22	0.87	50GKS00208	1+2	39TE009A	39BMKE03000BE	
	4700	B	ED	γ	M8 x 8	40	1.57	-	8	0.31	22	0.87	50GKS00208	1+2	39TE004A	39BMKE04700BE	
	7500	B	ED	γ	M8 x 8	52	2.05	-	8	0.31	22	0.87	50GKS00208	1+2	39TE005A	39BMKE07500BE	
	12000	B	ED	γ	M10 x 12	68	2.68	-	8	0.31	22	0.87	50GKS00208	1+2	39TE006A	39BMKE12000BE	
	18500	B	ED	γ	M10 x 12	90	3.54	-	8	0.31	22	0.87	50GKS00208	1+2	39TE007A	39BMKE18500BE	

E version

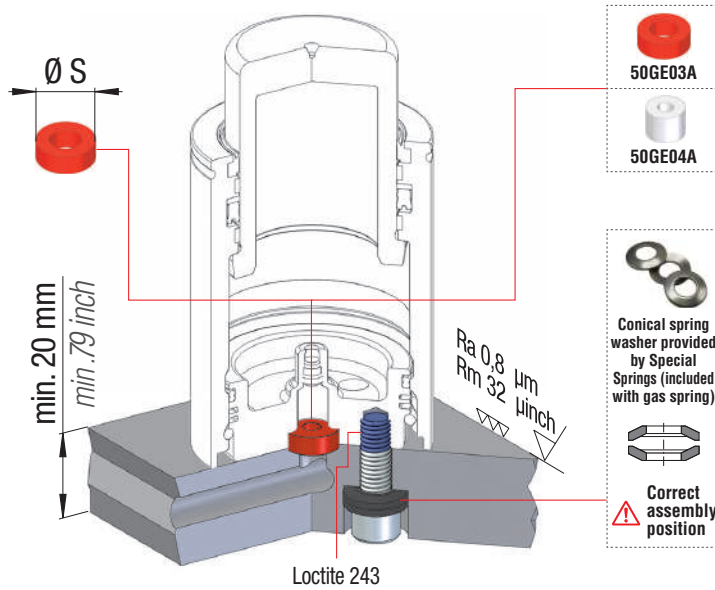

Example thread size M8 x 8

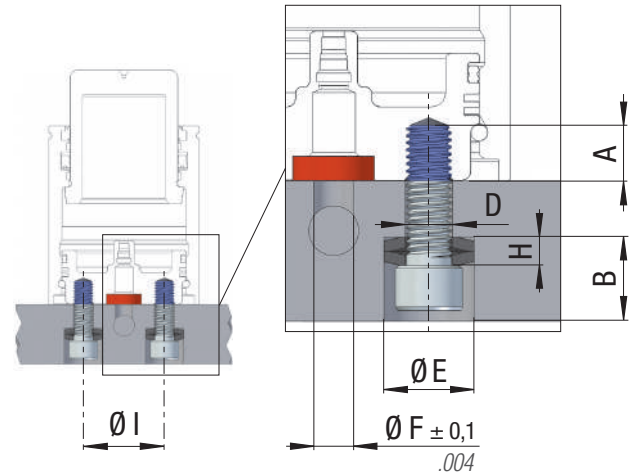

Ø I	D	A	B
Interasse fissaggio Fixing c.t.c. distance Mittenabstand Entraxe Distancia centros Distância eixos	Dimensione viti Screw dimension Schraubengröße Dimension vis Dimensión tornillos Dimensão parafusos	Profondità filetti Thread depth Gewindetiefe Profondeur filet Profundidad rosca Profundidade rosca	Profondità lamatura Depth of counterbore Senkungstiefe Profondeur du lamage Profundidad del contrataladro Profundida do alojamento

Ø E	Ø F	Ø S	H
Ø lamatura Ø counterbore Ø Senkung Ø lamage Ø Alojamiento Ø alojamento	Ø Foro piastra - cilindro Ø Plate - Gas spring hole Ø Platten - Zylinder Loch Ø Trou plaque - cylindre Ø Alojamiento Placa - Cilindro Ø Furo Placa - Cilindro	Ø Guarnizione piastra - cilindro Ø Plate - Gas spring seal Ø Platten - Zylinder Dichtung Ø Joint plaque - cylindre Ø Retén Placa - Cilindro Ø Junta Placa - Cilindro	Spessore rosette Thickness of washers Dicke Sichertheitscheiben Epaisseur des rondelles Espesor de las arandelas Espessura das arruelas

! Sostituire viti di fissaggio e rosette coniche ogni 1.000.000 di cicli.
 Replace fixing screws and conical spring washers every 1 million cycles.
 Alle 1 Mio. Hübe Befestigungsschrauben und Sicherheitscheiben austauschen.
 Remplacez les vis de fixation et les rondelles coniques à chaque million de cycles.
 Reemplazar los tornillos de fijación y las arandelas cónicas cada 1 millón de ciclos.
 Substituir a cada 1 milhão de ciclos os parafusos e arruelas de segurança.

Model	Ø E		B		H		Washer code for placement
	mm	inch	mm	inch	mm	inch	
ML 1000	≥ 10,25	≥ .40	≥ 9,15	≥ .36	3,15	.12	49RC06A
ML 1800	≥ 10,25	≥ .40	≥ 9,15	≥ .36	3,15	.12	49RC06A
ML 3000	≥ 17,3	≥ .68	≥ 12	≥ .47	4	.16	49RCHS08A
ML 4700	≥ 18,3	≥ .72	≥ 12	≥ .47	4	.16	49RC08A
ML 7500	≥ 18,3	≥ .72	≥ 12	≥ .47	4	.16	49RC08A
ML 12000	≥ 23,3	≥ .92	≥ 15	≥ .59	5	.20	49RC10A

MOUNTING HOLES

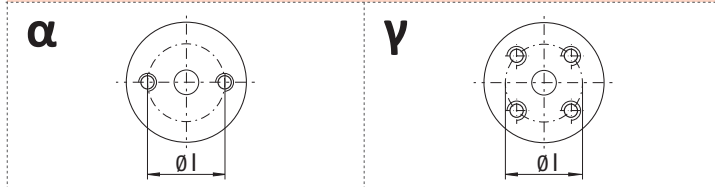

! **IT** Corse e ingombri uguali al cilindro autonomo
EN Strokes and sizes same to selfcontained gas spring
DE Hüben und Abmessungen gleiche zu den Autonomen Gdf
FR Courses et encombrement égaux à ceux du Cylindre autonome
ES Carreras y dimensiones iguales a las del cilindro autónomo
PT Cursos e dimensões iguais às do cilindro autónomo

NOTE

1 Modello con corpo liscio senza cave di fissaggio
 Model with straight body without fixing grooves
 Model mit flachem Körper ohne Befestigungsnuten
 Modèle avec corps lisse sans encoches de fixation
 Modelo con cuerpo liso sin ranuras para la fijación
 Modelo com corpo liso sem ranhuras de fixação

2 Modello con corpo senza foro di caricamento laterale
 Model with body without side charging port
 Model mit Körper ohne Nebenladeloch
 Modèle avec corps sans trou de charge latéral
 Modelo con cuerpo sin agujero lateral de carga
 Modelo com corpo sem orifício de carregamen

Series	Model	Rev. code	Version	Fixing pattern	Thread size D x A	Ø I		Ø F		Ø S		Seal code	Note	Cover code > see pag 257	Maintenance kit
						mm	inch	mm	inch	mm	inch				
ML	1000	D	E	α	M6 x 7	17	0,67	5	0,20	7,5	0,29	50GE04A	1+2	-	39BMML01000CE
	1800	D	E	γ	M6 x 8	26	1,02			14,5	0,57	50GE03A	1+2	39TE003A	39BMML01800CE
	3000	D	E	γ	M8 x 8	34	1,34	8*	0,31*	14,5	0,57	50GE03A	1+2	39TE009A	39BMML03000CE
	4700	D	E	γ	M8 x 8	40	1,57	or	or	14,5	0,57	50GE03A	1+2	39TE004A	39BMML04700CE
	7500	D	E	γ	M8 x 8	52	2,05	10	0,39	14,5	0,57	50GE03A	1+2	39TE005A	39BMML07500CE
	12000	D	E	γ	M10 x 8	68	2,68			14,5	0,57	50GE03A	1+2	39TE006A	39BMML12000CE

* : dimensione preferita - preferred size - bevorzugte Größe - dimension préférée - tamaño preferido - tamanho preferido

E - EV version

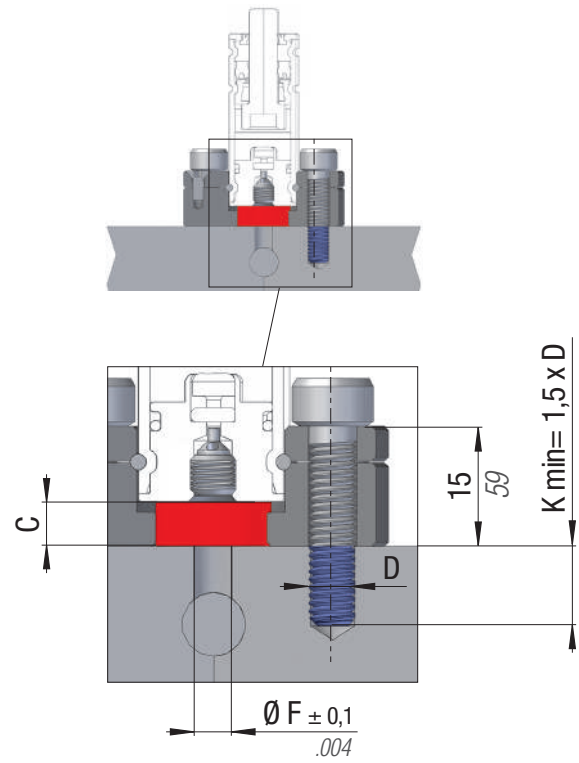
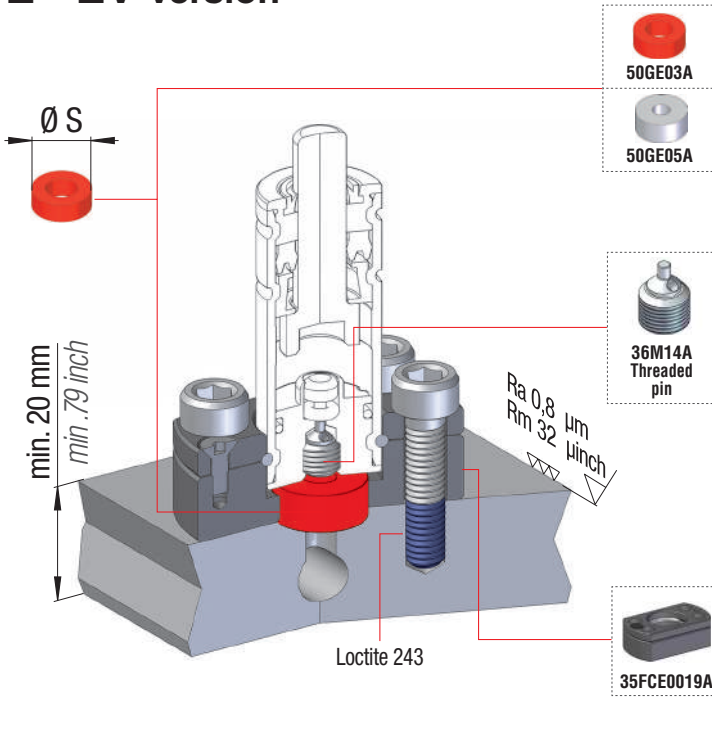

D	K min	Ø F	Ø S
Dimensione viti Screw dimension Schraubengröße Dimension vis Dimensión tornillos Dimensão parafusos	Minimo impegno viti Minimum thread engagement Mindest-Einschraublänge Longueur minimum à visser min Longitud roscada mínima Comprimento mínimo roscado	Ø Foro piastra - cilindro Ø Plate - gas spring hole Ø Platten - zylinder loch Ø Trou plaque - cylindre Ø Alojamiento Placa - Cilindro Ø Furo placa - Cilindro	Ø Guarnizione piastra - cilindro Ø Plate - gas spring seal Ø Platten - zylinder dichtung Ø Joint plaque - cylindre Ø Retén Placa - Cilindro Ø Junta Placa - cilindro

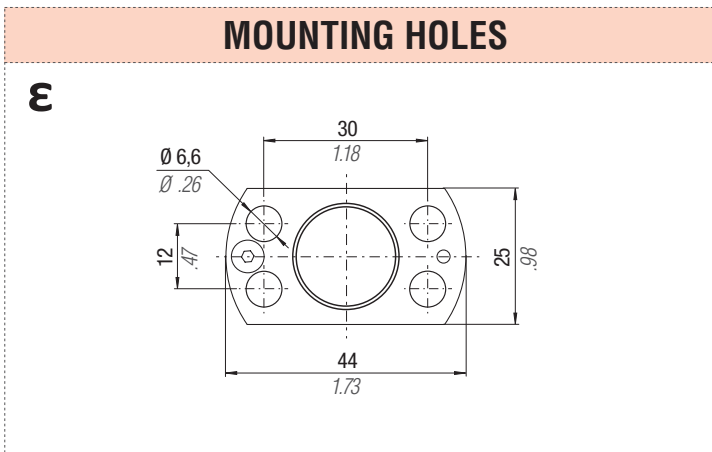

NOTE

- Modello con corpo liscio senza cave di fissaggio
Model with straight body without fixing grooves
Model mit flachem Körper ohne Befestigungsnuten
Modèle avec corps lisse sans encoches de fixation
Modelo con cuerpo liso sin ranuras para la fijación
Modelo com corpo liso sem ranhuras de fixação
- Modello con corpo senza foro di caricamento laterale
Model with body without side charging port
Model mit Körper ohne Nebenladeloeh
Modèle avec corps sans trou de charge latéral
Modelo con cuerpo sin agujero lateral de carga
Modelo com corpo sem orificio de carregamen



IT Corse uguali al cilindro autonomo
EN Strokes same to selfcontained gas spring
DE Hüben gleiche zu den Autonomen Gdf

FR Courses égales à celles du Cylindre autonome
ES Carreras iguales a las del cilindro autónomo
PT Cursos iguais às do cilindro autónomo

Series	Model	Rev. code	Version	Mounting holes	Thread size D	Ø F		Ø S		C		Seal code	Note
						mm	inch	mm	inch	mm	inch		
RV	170 *	C	E	ε	M6	5	0.20	14,5	0.57	4,6	0.18	50GE03A	2
RS	170 *	C	E	ε	M6	5	0.20	14,5	0.57	4,6	0.18	50GE03A	2
M	90 *	B	EV	ε	M6	5	0.20	14,5	0.57	5,6	0.22	50GE05A	2
MS	90 *	B	E	ε	M6	5	0.20	14,5	0.57	5,6	0.22	50GE05A	2

* : sicurezza OSAS e OPAS non disponibile - Safety features OSAS and OPAS not available - Sicherheitsfeatures OSAS und OPAS nicht verfügbar - Dispositivos de seguridad OSAS et OPAS non disponibles - Dispositivos de seguridad OSAS y OPAS no disponibles - Dispositivos OSAS e OPAS não disponíveis



HOW TO ORDER



IT Stato di fornitura

Tutti i cilindri Easy manifold sono forniti con guarnizione e foglio istruzioni.

EN Supply status

All Easy Manifold gas springs are supplied with seal and operating instructions .

DE Lieferumfang

Alle Gasdruckfeder Easy Manifold sind mit Dichtung und Bedienungsanleitungen ausgestattet.

FR État de fourniture

Tous les vérins Easy manifold sont fournis avec un joint et une fiche d'instructions.

ES Condiciones de suministro

Todos los cilindros Easy manifold se suministran con reten y hoja de instrucciones.

PT Estado de abastecimento

Todos os cilindros Easy manifold vêm com uma junta e um folheto de instruções.

Easy manifold control panel

code 39CP01A-...

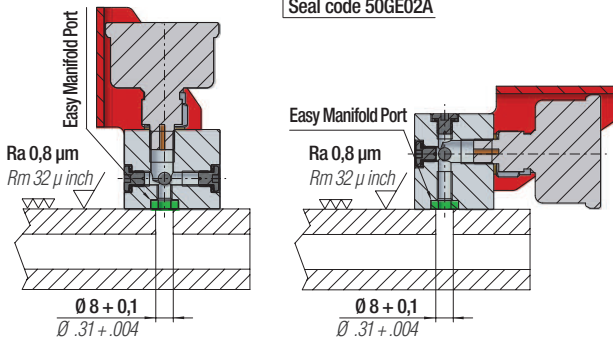
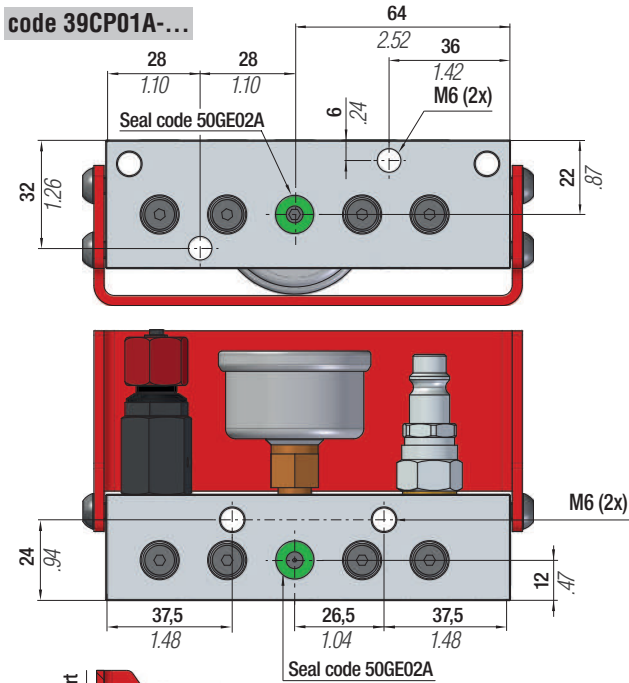

code 39CPVC-...

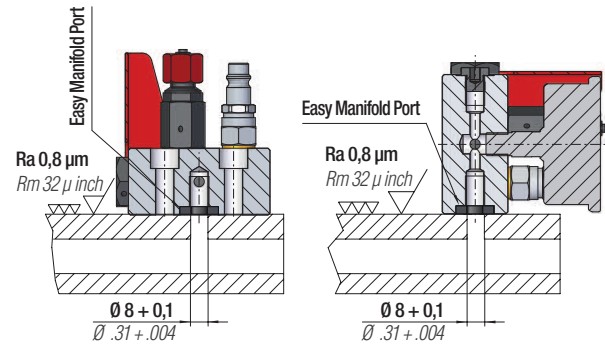
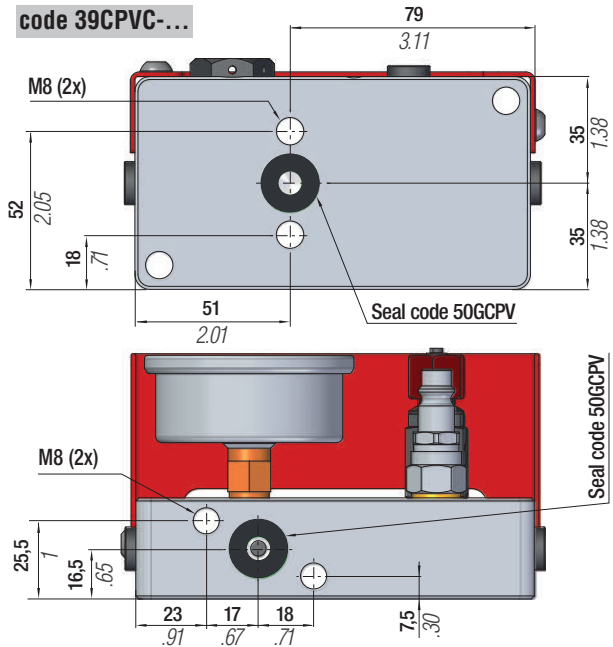

code 39MCPC-... / 39CP19A-...

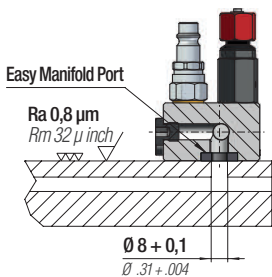
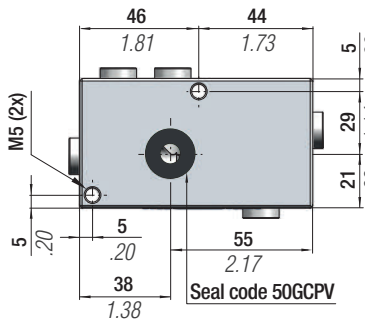

code 39CP14A-...

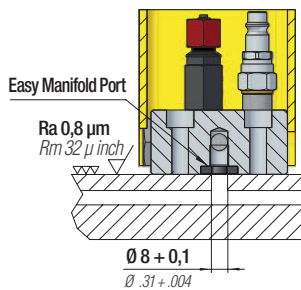
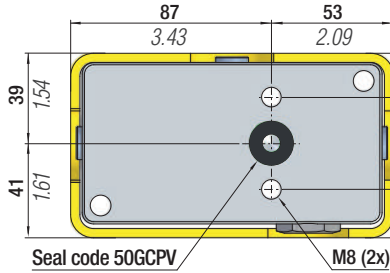

code 39CP07A... / 39CP10A... / 39CP12A-...

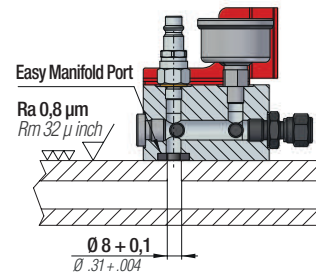
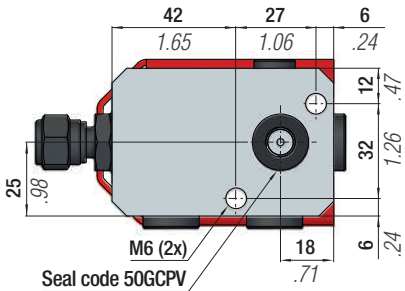

How to plug plate holes

IT Quando è richiesta una riduzione della forza del sistema, o del numero di cilindri, è possibile tappare i fori non utilizzati con una copertura dotata di guarnizione, che utilizza gli stessi fissaggi dei cilindri.

EN When a reduction either of the system's force, or of the number of gas springs, is required, it is possible to plug the holes which are not used, with a cover provided with a square seal, through the same fixing hoses of the gas springs.

DE Wenn die Systemkraft oder die Anzahl der Zylinder reduziert werden soll, können nicht benötigte Bohrungen mit einem Stöpsel verschlossen und abgedichtet werden, der die selben Befestigungen wie die Zylinder benutzt.

FR Quand une réduction de la force du système ou du nombre des vérins est requise, on peut boucher les trous qui ne sont pas utilisés, avec un couvercle équipée avec un joint, qui utilise les mêmes trous de fixations des vérins.

ES Cuando se requiere de una reducción de la fuerza del sistema o del número de cilindros, se pueden tapar los alojamientos no utilizados con una tapa equipada con retenes que tiene los mismos agujeros de fijación que los cilindros.

PT Quando você solicita uma redução na força do sistema, ou o número de cilindros, pode tapar os buracos não utilizados com uma tampa com vedação, que usa o mesmo buracos dos cilindros.

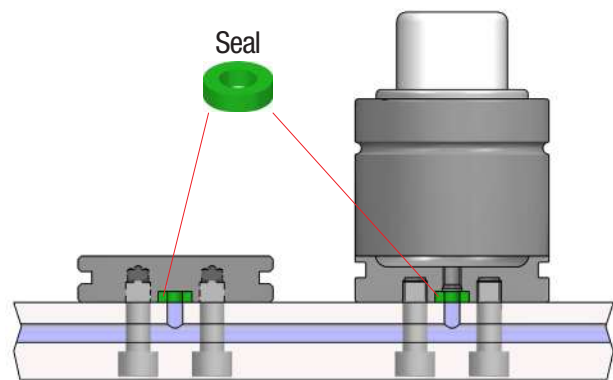
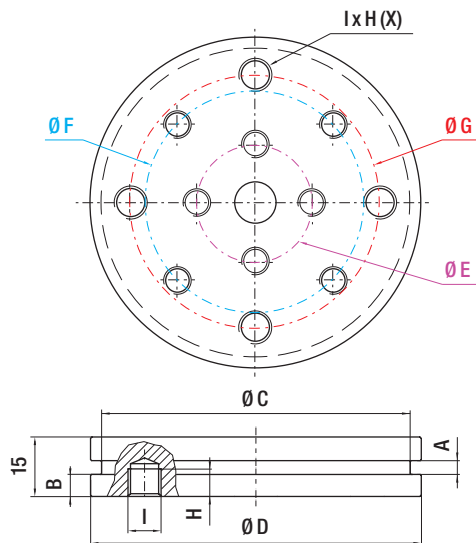

Code	A		B		Ø C		Ø D		Ø E		Ø F		Ø G		I (x)	H		Seal Code
	mm	inch	mm	inch	mm	inch	mm	inch	mm	inch	mm	inch	mm	inch		mm	inch	
39TE012A	3,5	0.14	4	0.16	27	1.06	32	1.26	18	0.71	-	-	-	-	M6 (2x)	10	0.39	50GE02A
39TE010A	3,5	0.14	4	0.16	27	1.06	32	1.26	20	0.79	24	0.94	-	-	M6 (2x)	10	0.39	50GE02A
39TE001A	3,5	0.14	4	0.16	33	1.30	38	1.50	20	0.79	-	-	-	-	M6 (4x)	10	0.39	50GE02A
39TE011A	3,5	0.14	4	0.16	40	1.06	45	1.77	20	0.79	-	-	-	-	M8 (2x)	10	0.39	50GE02A
39TE002A	3,5	0.14	4	0.16	40	1.57	45	1.77	26	1.02	-	-	-	-	M8 (4x)	10	0.39	50GE01A
39TE003A	5	0.20	8	0.31	43	1.69	50	1.97	26	1.02	-	-	-	-	M6 (4x)	10	0.39	50GE01A
									-	-	34	1.34	-	-	M8 (4x)	10	0.39	
39TE009A	5	0.20	8	0.31	56	2.20	63	2.48	34	1.34	-	-	-	-	M8 (4x)	10	0.39	50GE01A
39TE004A	5	0.20	8	0.31	67	2.64	75	2.95	40	1.57	-	-	-	-	M8 (4x)	10	0.39	50GE01A
									-	-	53,9	2.12	-	-	M12 (4x)	10	0.39	
39TE005A	5	0.20	8	0.31	87	3.43	95	3.74	52	2.05	60	2.36	-	-	M8 (4x)	10	0.39	50GE01A
									-	-	-	-	76,2	3.00	M12 (4x)	10	0.39	
39TE006A	5	0.20	8	0.31	112	4.41	120	4.72	80	3.15	-	-	68	2.68	M10 (4x)	10	0.39	50GE01A
									-	-	80,8	3.18	-	-	M12 (4x)	10	0.39	
39TE007A	5	0.20	8	0.31	142	5.59	150	5.91	100	3.94	-	-	90	3.54	M10 (4x)	10	0.39	50GE01A
									-	-	100	3.94	-	-	M12 (4x)	10	0.39	
39TE008A	8	0.31	8	0.31	187	7.36	195	7.68	120	4.72	-	-	-	-	M12 (4x)	10	0.39	50GE01A

Mounting recommendations

! It is always required Loctite 243 or equivalent and the safety washers

Chiave dinamometrica
Torque wrench
Drehmomentschlüssel
Clé dynamométrique
Llave dinamométrica
Chave dinamométrica

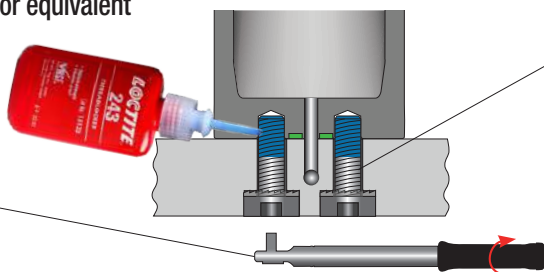

Torque force		
M6	class \geq 8.8	max 10 Nm
M8	class \geq 8.8	max 24 Nm
M10	class \geq 8.8	max 50 Nm
M12	class \geq 8.8	max 84 Nm

IT Raccomandazioni

- L' uso di viti di classe superiore alla 8.8, come 9.8, 10.9 e 12.9, è sempre possibile (questa indicazione non vale per ML, MP e MQ).
- Si raccomanda di NON SUPERARE i valori della coppia di serraggio indicati per la classe 8.8 per qualsiasi classe di viti utilizzata.
- Impegnare sempre il filetto il più possibile, almeno il valore di Kmin.
- Massima attenzione nel montaggio della guarnizione di collegamento tra cilindro e piastra.

- Utilizzare SEMPRE i fori di fissaggio previsti.
- Massima attenzione alla corretta coppia di serraggio da applicare alle viti.
- Usare SEMPRE rondelle anti svitamento su cilindri e pannelli.
- Usare SEMPRE frena filetti tipo Loctite 243 su cilindri e pannelli.
- Non caricare il sistema Easy Manifold con pressione superiore alla massima consentita per ogni modello.

EN Recommendations

- The use of screws of higher class than 8.8, such as 9.8, 10.9 and 12.9, is always allowed (this information is not valid for the Series ML, MP e MQ).
- DO NOT EXCEED the fixed values for torque force indicated for class 8.8, in any other class of screws used.
- ALWAYS engage thread as much as possible at least Kmin.
- Extreme caution when assembling the connecting seal between plate and gas spring.

- ALWAYS use the fixing holes provided.
- Extreme caution to tightening torque to be applied to screws.
- ALWAYS use lock washers on gas springs and panels.
- ALWAYS use thread lock LOCTITE 243 on gas springs and panels.
- Do not charge the easy manifold system over the maximum allowed pressure for each gas spring model.

DE Hinweise

- Schrauben mit einer höheren Festigkeit als 8.8 verwenden. Höhere Festigkeitsklassen wie 9.8, 10.9 und 12.9 sind immer möglich (Diese Angabe gilt nicht für die Baureihen ML, MP und MQ).
- Das angegebene Drehmoment der Festigkeitsklasse 8.8 für andere Schrauben Festigkeitsklassen nicht überschreiten.
- Die komplette Gewindelänge ausnutzen, mind. Kmin.
- Vorsicht bei der Montage der Dichtungen zwischen den Gasdruckfedern und der Platte.
- Äußerste Vorsicht bzgl. des korrekten Drehmoments beim Einschrauben.

- IMMER die vorgesehen Befestigungslöcher verwenden
- IMMER Sicherungsscheiben auf die Zylindern und Kontrollarmaturen, verwenden.
- IMMER eine Schraubensicherung wie z.B. Loctite 243 auf die Zylindern und Kontrollarmaturen, verwenden.
- Das Easy Manifold System nicht mit einem höheren Druck laden als dem, der speziell für das Modell der Gasdruckfeder empfohlen wird.

FR Reccomandacions

- L'usage de vis de classe supérieure au 8.8, tout comme 9.8, 10.9 et 12.9, est toujours possible (cette information n'est pas valable pour les séries ML, MP et MQ).
- N'EXCEDEZ PAS la valeur de la couple de serrage indiqués pour la classe 8.8 pour n'importe quelle autre classe de vis utilisée.
- Engager toujours le filetages plus que possible, et au moins Kmin.
- Une extrême vigilance est recommandée pour l'assemblage du joint entre la plaque et le vérin.

- Utiliser TOUJOURS les trous de fixation prévus.
- Bien veiller à appliquer le couple de serrage correct aux vis.
- TOUJOURS utiliser les rondelles de verrouillage avec les cylindres et les panneaux.
- TOUJOURS utiliser la colle frein filet LOCTITE 243 avec les cylindres et les panneaux.
- Ne pas charger le système manifold au delà de la pression autorisée pour chaque modèle de vérin.

ES Recomendaciones

- El uso de tornillos de calidad superior a 8.8, como 9.8, 10.9 y 12.9 está permitido (excepto para ML, MP y MQ).
- Se recomienda NO EXCEDER el par de apriete indicado para la clase 8.8 para cualquier calidad de tornillos utilizados.
- Utilizar la máxima longitud de rosca, como mínimo Kmin.
- Máxima atención en el montaje de la junta de conexión entre placa y cilindro.

- SIEMPRE use los agujeros de fijación previstos.
- Máxima atención al correcto par de torsión que se aplica a los tornillos.
- Utilizar SIEMPRE arandelas autoblocantes por los cilindros y paneles.
- Utilizar SIEMPRE fijador de rosca tipo Loctite 243 por los cilindros y paneles.
- No cargar el sistema Easy Manifold con presión superior a la máxima permitida para cada tipo de cilindro.

PT Recomendações

- O uso de limitadores superiores a 8,8, tal como 9,8, 10,9 e 12,9, é sempre possível (não valido para as linhas ML, MP e MQ).
- Recomendamos que você NÃO ULTRAPASSE os valores das especificações de torque para a classe 8,8 por os limitadores utilizados para qualquer classe.
- Sempre envolver a rosca, tanto quanto possível, pelo menos para Kmin.
- Máxima atenção quando fixar os vedantes conectores entre a placa e cilindro.

- Use SEMPRE os furos de fixação fornecidos.
- Máxima atenção no torque de aperto aplicado nos parafuso.
- Utilizar SEMPRE as anilhas de travamento nos cilindros e painéis.
- Utilizar SEMPRE o fixador de rosca LOCTITE 243 nos cilindros e painéis.
- Não carregar o sistema EASY MANIFOLD acima da pressão máxima recomendada para cada modelo de cilindro.



THIS PAGE IS INTENTIONALLY LEFT BLANK





IT Oltre alla protezione SKUDO installata come standard sulle serie KE, RS ed MS, Special Springs offre una completa gamma di raschiatori secondari per migliorare le prestazioni dei cilindri ad azoto utilizzati in ambienti molto contaminati. I nuovi raschiatori secondari in poliuretano sono progettati per un perfetto fitting con i vari modelli di cilindri. Vedi le tabelle per i dati tecnici. I raschiatori secondari sono ordinabili separatamente dal cilindro ad azoto e installabili dall'utilizzatore o, se richiesti al momento dell'ordine, installati direttamente in fabbrica da Special Springs.

EN In addition to the SKUDO protection, which is standard on series KE, RS and MS, Special Springs offers a complete range of secondary wipers to improve performances of gas springs used in heavy contaminated environments. The new secondary wipers, made in polyurethane, are designed for a perfect fitting with many series of gas springs. See the charts for technical data. The secondary wipers can be ordered separately from the gas springs. They can be assembled by user or, if requested with the order, by Special Springs.

DE Neben dem SKUDO-Schutz, der standardmäßig auf der Produktreihe KE, RS und MS installiert ist, bietet Special Springs ein komplettes Sortiment an Sekundärabstreifer zur Verbesserung der Leistungen von Gasdruckfedern, die in stark kontaminierten Umgebungen eingesetzt werden. Die neuen Sekundärabstreifer, hergestellt aus Polyurethan, sind für eine perfekte Montage mit vielen Serien von Gasdruckfedern ausgelegt. Siehe die Tabelle für technische Daten. Die Sekundärabstreifer können separat von den Gasdruckfedern bestellt und vom Anwender montiert werden oder, falls in der Bestellung gewünscht, werkseitig vormontiert von Special Springs.

FR En plus de la protection SKUDO installée en standard sur les séries KE, RS et MS, Special Springs offre une gamme complète de joints racleurs secondaires pour améliorer les performances des ressorts à gaz utilisés dans les environnements fortement contaminés. Les nouveaux joints racleurs secondaires, fabriqués en polyuréthane, sont conçus pour une parfaite fixation avec de nombreuses séries de ressorts à gaz. Voir les tableaux pour les données techniques. Les joints racleurs secondaires peuvent être commandés séparément des cylindres et assemblés par l'utilisateur ou, si demandé dans la commande, seront assemblés en usine par Special Springs.

ES Además de la protección SKUDO instalada como estándar en las series KE, RS y MS, Special Springs ofrece una gama completa de rascadores secundarios para mejorar las prestaciones de los cilindros de nitrógeno en caso de uso en entornos especialmente contaminados. Los nuevos rascadores secundarios de poliuretano están diseñados para un ajuste perfecto con varios modelos de cilindros de nitrógeno. Consulte las tablas para obtener información técnica. Los rascadores secundarios se pueden pedir por separado y ser montados por el usuario o, si se solicita en el pedido, se montarán en fábrica por Special Springs.

PT Além da protecção SKUDO instalada como padrão na série KE, RS e MS, Special Springs oferece uma gama completa de raspadores secundários para melhorar os desempenhos dos cilindros de nitrogênio utilizados em ambientes muito contaminados. Os novos raspadores secundários, feitos de poliuretano, são projetados para um perfeito montagem com muitas séries de cilindros de nitrogênio. Veja a guia abaixo para obter dados técnicos. Os raspadores secundários podem ser encomendados separadamente dos cilindros e montados pelo usuário ou, se solicitado com a ordem, serão montados na fábrica por Special Springs.

HOW TO ORDER

E.g. How to order a gas spring with Secondary Wiper **already installed**

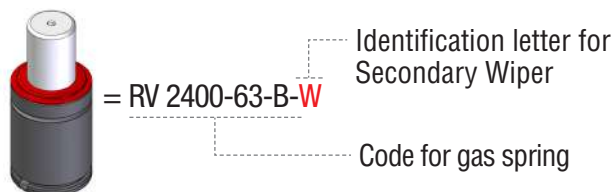

E.g. How to order **only** the Secondary Wiper



Gas spring Code	A mm	B mm	Secondary Wiper Code
M 300	2	4	59SW001
RV / RS / RT 350	2	4	59SW002
RV / RS / RT 500	2	4	59SW003
RV / RS / RF / RG / RT 750	2	4	59SW004
RV / RS / RF / RG / RT 1000	2	5	59SW005
RV / RS / RF / RG / RT 1200	2	5	59SW005
RV / RS / RF / RG / RT 1500	2,5	5,5	59SW006
RV / RS / RF / RG / RT 2400	2,5	5,5	59SW007
RV / RS / RG / RT 4200	2,5	5,5	59SW008
RV / RS / RG / RT 6600	2,5	5,5	59SW009
RV / RS / RT 9500	3	6	59SW010
RV 12000	3	6	59SW011
RV 20000	3	6	59SW012
H 300	2	4	59SW002
H / HF 500	2	4	59SW003
HT 500	2	4	59SW047
H 700	2	4	59SW004
HT 700	2	4	59SW048
H 1000	2	5	59SW005
HT 1000	2	5	59SW049
H 1500	2,5	5,5	59SW006
H 2400	2,5	5,5	59SW007

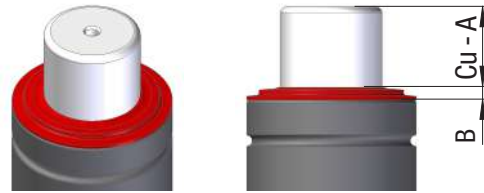

A = Nominal stroke reduction

Cu = Nominal Stroke

Gas spring Code	A mm	B mm	Secondary Wiper Code
H 4200	2,5	5,5	59SW008
H 6600	2,5	5,5	59SW009
H 9500	3	6	59SW010
H 18500	3	6	59SW013
H 20000	3	6	59SW012
SC 150 / SC 200	2	4	59SW014
SC / SCF 250	2	4	59SW015
S / SC 500	2	4	59SW016
S / SC 750	2	5	59SW017
S / SC 1500	2,5	5,5	59SW018
S / SC 3000	2,5	5,5	59SW019
SC 5000	3	6	59SW020
SC 7500	3	6	59SW021
SC 10000	3	6	59SW022

⚠ The installation of the secondary wiper requires the removal of the active safety marker OSM where mounted.

Gas spring Code	A mm	B mm	Secondary Wiper Code
KE 750	2	2	59SW070
KE 1000	2	2	59SW059
KE 1800	2	2	59SW071
KE 3000	2	2	59SW072
KE 4700	2	2	59SW073
KE 7500	2,5	2,5	59SW074
KE 12000	2,5	2,5	59SW075
KE 18500	3	3	59SW076

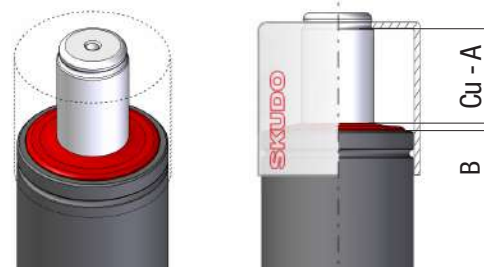

A = Nominal stroke reduction

Cu = Nominal Stroke

⚠ The installation of the secondary wiper requires the removal of the outer seal. SW and Skudo can be mounted together.

Gas spring Code	A mm	B mm	Ø D mm	Secondary Wiper Code
M 50	-	9,5	15	59SW023
M 70	-	9,5	18	59SW024
M 90 rev. B	0,5	10,5	22	59SW045
M 200 rev. B	0,5	10,5	28	59SW046
RV 170	1,5	9,5	22	59SW027
RV 320	1,5	9,5	28	59SW028
ML 300 rev. D	1,5	11,5	29	59SW030
ML 500 rev. D	1,5	11,5	36	59SW031
ML 1000 rev. D	1,5	11,5	42	59SW032
ML 1800 rev. D	0,5	11,5	54	59SW033
ML 3000 rev. D	0,5	11,5	67	59SW034
ML 4700 rev. D	0,5	11,5	79	59SW035
ML 7500 rev. D	0,5	11,5	100	59SW036
ML 12000 rev. D	0,5	11,5	125	59SW037
MP 150	2,5	9,5	22	59SW083
MP 500	1,5	33	36	59SW043

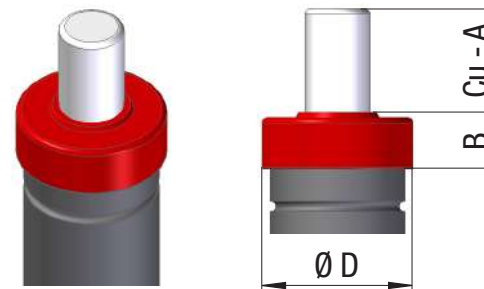

A = Nominal stroke reduction

Cu = Nominal Stroke

Gas spring Code	A mm	B mm	Ø D mm	Secondary Wiper Code
MP 1000	1,5	19	42	59SW044
MP 2000	1,5	21	54	59SW061
MP 3000	0,5	21	67	59SW082
KE 400	1	14,5	28	59SW069

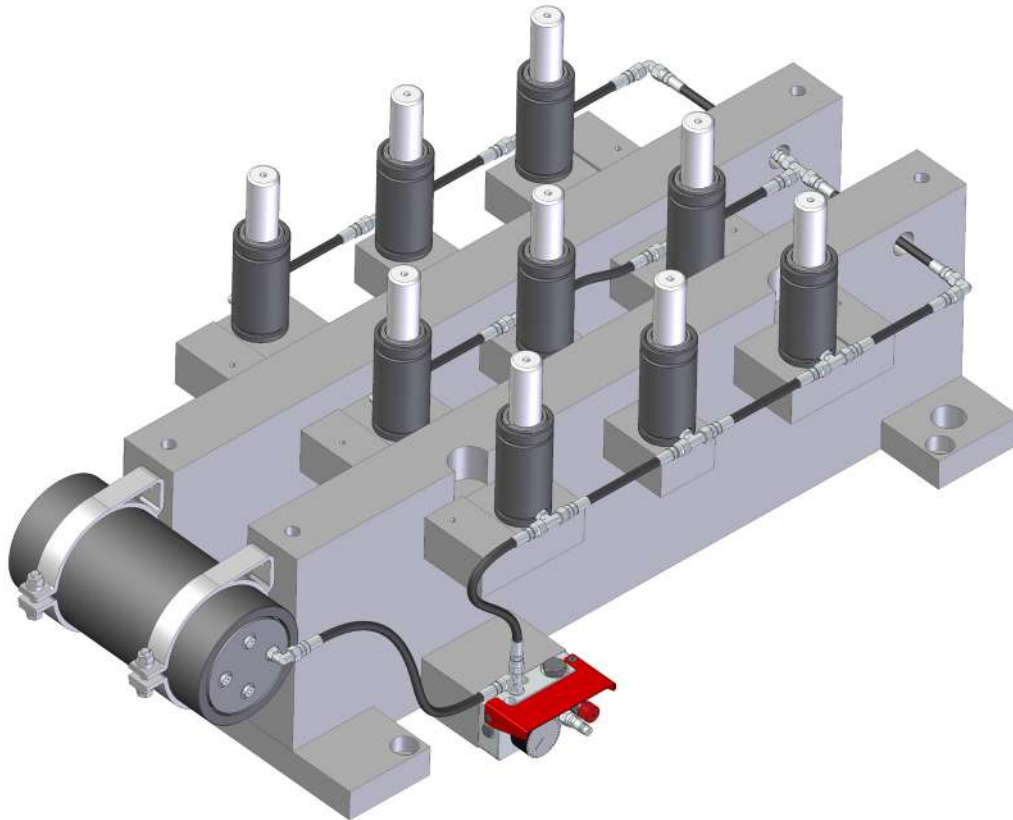

IT VANTAGGI

- Pressione uguale in tutti i cilindri
- Controllo della pressione = controllo della forza
- Aumento/riduzione della pressione = aumento/riduzione della forza attraverso il pannello di controllo (regolazione possibile anche con il sistema in lavoro, senza intervento diretto sui cilindri)
- Utilizzo di polmoni di compensazione per un ridotto incremento della pressione a fine compressione
- Gestione di impianti e forze diverse nello stesso stampo (uso multipannello MCPC+AUMCP)
- Stop di sicurezza con uso pressostato
- Utilizzo tappo di sicurezza con disco di rottura CE
- Flessibilità di collegamento con tubi e raccordi EO - 24°, JIC 37°, FlexFlow, Micro 32°, ORFS



I cilindri collegabili a sistema (codice modello + N/NA) sono forniti privi di valvola unidirezionale e con corpo/fondello speciale dove previsto. Per le serie S/SC/H/KE/RV/RS/RF/RG/RT/LS/ML/HT è possibile trasformare i cilindri autonomi in cilindri collegabili a sistema semplicemente rimuovendo i dispositivi di tenuta dal foro di caricamento. Scaricare completamente la pressione prima di questa operazione. Qualora si rendesse necessario rimuovere uno qualsiasi dei componenti installati, scaricare completamente la pressione attraverso il pannello.

EN BENEFITS

- Same pressure in all gas springs
- Pressure control = force control
- Pressure increase/decrease = force increase/decrease through the control panel (the adjustment is also possible with the system running, without direct intervention on the cylinders)
- Lower pressure increase by using compensation tank
- Possibility to manage different systems and forces in the same tool by using the multipanel
- MCPC+AUMCP
- Safe stop function through pressure switch
- Use of the safety plug with rupture disc CE
- Flexible linking by using hose and connection EO - 24°, JIC 37°, FlexFlow, Micro 32°, ORFS and couplings and many useful accessories



The hoses system gas springs (model code + N/NA) are supplied without charging valve and with special body/end plate when specified. However S/SC/H/KE/RV/RS/RF/RG/RT/LS/ML/HT series can be converted from self-contained to hoses system by simply removing the charging valve. Be sure that all pressure is exhausted before starting this operation. In case it's necessary to remove any of the installed components, pressure must be fully exhausted through the control panel.

DE VORTEILE

- Identischer Druck in allen Zylindern
- Druckkontrolle = Kraftkontrolle
- Druck erhöhen/mindern = Kraft erhöhen/mindern über das Bedienfeld (Einstellung auch beim laufenden System möglich, ohne direkten Eingriff in die Zylinder)
- Einsatz von Ausgleichbehältern zur Reduzierung von Druckerhöhungen
- Verwaltung verschiedenartiger Anlagen und Leistungen in demselben Werkzeug über die Multisteuerung MCPC+AUMCP
- Sicherheitsstopp per Druckwächter
- Verwendung eines Sicherheitsverschlusses mit Berstscheibe (CE-Kennzeichnung)
- Flexibilität bei der Verbindung mit Rohren und Anschlüssen EO - 24°, JIC 37°, FlexFlow, Micro 32°, ORFS



Zylinder im Verbund (Modellcode + N/NA) werden ohne Einwegventile und, sofern vorgesehen, mit speziellem Gehäuse/Boden geliefert. Für die Serien S/SC/H/KE/RV/RS/RF/RG/RT/LS/ML/HT können die autonomen arbeitenden Zylinder im Verbund im Verbund abgeändert werden, indem die Dichtungsvorrichtungen an der Luftzufuhröffnung entfernt werden. Lassen Sie die Druckluft vor diesem Arbeitsschritt komplett ab. Falls es sich als notwendig erweisen sollte, einen der installierten Komponenten zu entfernen, muss vorher die Druckluft mittels der Steuerung vollständig abgelassen werden.

FR AVANTAGES

- La même pression dans tous les ressorts
- Contrôle de la pression = contrôle de la force
- Augmentation/diminution de la pression = augmentation/diminution de la force depuis le panneau de control (le réglage est possible même si le système est en fonction, sans intervention directe sur les vérins)
- Utilisation de réservoirs de compensation produisant une petite augmentation de la pression à la fin de la compression
- Gestion d'installations et de forces différentes sur le même outil (utilisation multi-panneaux MCPC+AUMCP)
- Arrêt de sécurité à l'aide d'un pressostat
- Utilisation d'un bouchon de sécurité avec disque de rupture CE
- Souplesse du raccordement à l'aide de tubes et de raccords EO - 24°, JIC 37°, FlexFlow, Micro 32°, ORFS



Les ressorts pouvant être reliés à un système (référence modèle + N/NA) sont livrés sans la vanne unidirectionnelle et avec corps/fond spécial si prévu. Pour les séries S/SC/H/KE/RV/RS/RF/RG/RT/LS/ML/HT, il est possible de transformer les ressorts autonomes en cylindres pouvant être reliés à un système en ôtant simplement les dispositifs d'étanchéité du trou de chargement. Décharger complètement la pression avant d'effectuer cette opération. S'il est nécessaire de démonter un des composants installés, décharger complètement la pression par l'intermédiaire du panneau de contrôle.

ES VENTAJAS

- Misma presión en todos los cilindros
- Control de la presión = control de la fuerza
- Aumento/disminución de la presión = aumento/disminución de la fuerza a través del panel de control (regulación posible incluso con el sistema en marcha, sin intervención directa en los cilindros)
- Pueden emplearse pulmones de compensación para reducir el aumento de la presión al final de la compresión
- Gestión de instalaciones y fuerzas distintas en el mismo útil (con uso del multipanel MCPC+AUMCP)
- Parada de emergencia con uso de presostat
- Tapón de seguridad con disco de ruptura CE
- Flexibilidad de conexión con tubos y racores EO - 24°, JIC 37°, FlexFlow, Micro 32°, ORFS



Los cilindros conectables (código modelo + N/NA) se suministran sin válvula unidireccional y con cuerpo/base especiales en los casos en que así se requiera. En las series S/SC/H/KE/RV/RS/RF/RG/RT/LS/ML/HT, los cilindros autónomos pueden transformarse en cilindros conectables simplemente quitando los dispositivos de estanqueidad del orificio de carga. Antes de realizar esta operación, vaciar completamente la presión. Si fuera necesario quitar alguno de los componentes instalados, vaciar completamente la presión mediante el panel de control.

PT VANTAGENS

- Pressão igual em todos os cilindros
- Controlo da pressão = controlo da força
- Aumento/Redução da pressão = Aumento/Redução da força através do painel de controle (É possível regular, inclusive, com o sistema trabalhando, sem nenhuma intervenção nos cilindros)
- Utilização dos tanques de compensação para redução do aumento da pressão no final da compressão
- Gestão de instalações e de várias forças na mesma Ferramenta (uso do multi-painel MCPC+AUMCP)
- Stop de segurança com utilização do pressostat
- Utilização de Bujão de segurança com disco de rotura CE
- Flexibilidade de ligação com tubos e ligações EO - 24°, JIC 37°, FlexFlow, Micro 32°, ORFS



Os cilindros ligáveis em sistema (código do modelo + N/NA) são fornecidos sem válvula unidireccional e com corpo/extremidade especial. Para a série S/SC/H/KE/RV/RS/RF/RG/RT/LS/ML/HT, é possível transformar os cilindros autónomos em cilindros ligáveis em sistema, bastando remover os dispositivos de retenção do orifício de carga. Descarregar completamente a pressão antes desta operação. No caso de ser necessário remover um dos componentes instalados, descarregar completamente a pressão através do painel de controlo.



LINKED SYSTEM OPERATING INSTRUCTIONS



- IT** Conservare tubi e raccordi lontano da fonti di calore e luce solare diretta (raggi UV).
- EN** Store hoses and fittings away from heat sources and direct sunlight (UV radiation).
- DE** Lagern Sie Schläuche und Anschlussstücke fern von Wärmequellen und direktem Sonnenlicht (UV-Strahlung).
- FR** Conserver tuyaux et raccords à l'écart de toute source de chaleur et de la lumière directe du soleil.
- ES** Conservar mangueras y racores alejados de fuentes de calor y de la luz solar directa (rayos UV).
- PT** Manter mangueiras e conexões longe do calor e da luz do sol.

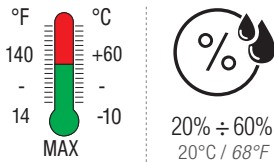

- IT** Conservare tubi e raccordi protetti da alte temperature e dal contatto con oli di stampaggio, solventi, acidi e fluidi aggressivi in genere (ad es. soda e cloruri).
- EN** Keep hoses and fittings protected against high temperatures and contact with oils, solvents, acids and aggressive fluids in general (e.g. soda and chlorides).
- DE** Halten Sie Schläuche und Anschlussstücke geschützt vor hohen Temperaturen und dem Kontakt mit Schmierstoffen für die Metallbearbeitung, Lösungsmitteln, Säuren und aggressiven Flüssigkeiten im Allgemeinen (z. B. Soda und Chloride).
- FR** Protégez les tuyaux et les raccords contre les températures élevées et le contact avec les huiles, les solvants, les acides et les fluides agressifs en général (par exemple, la soude et les chlorures).
- ES** Conservar mangueras y racores protegidos de altas temperaturas y del contacto con aceites de estampación, disolventes, ácidos y fluidos agresivos en general (por ejemplo, soda y cloruros).
- PT** Manter tubos e conexões longe de altas temperaturas e de contato com oleos, solventes, acidos ou qualquer outro elemento agressivo aos materiais (ex. solda, cloro, etc..).



- IT** Nella produzione del tubo rispettare le istruzioni operative indicate nel manuale d'uso della pressa pneumatica 39PR06.
- EN** When producing the hoses, follow the instructions given in the user manual of the hydraulic press 39PR06.
- DE** Bei der Herstellung des Schlauchs die Angaben in der Betriebsanleitung der pneumo-hydraulischen Schlauchpresse 39PR06 beachten.
- FR** Lors de la fabrication des tuyaux, suivez les instructions données dans le manuel d'utilisation de la presse hydraulique 39PR06.
- ES** A la hora de fabricar las mangueras, seguir las instrucciones de funcionamiento indicadas en el manual del usuario de la prensa neumohidráulica 39PR06.
- PT** Para cravamento das mangueiras, respeitar as orientações do manual de instruções da prensa pneumática 39PR06.

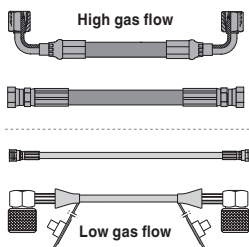

- IT** Selezionare tubi e raccordi idonei per l'applicazione.
- EN** Select hoses and fittings suitable for the system.
- DE** Für die Anwendung geeignete Schläuche und Anschlussstücke auswählen.
- FR** Sélectionnez les tuyaux et les raccords adaptés au système.
- ES** Seleccione mangueras y racores adecuados para su aplicación.
- PT** Selecionar os tubos e conexões de acordo com a necessidade.

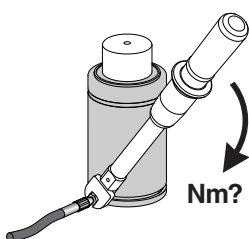

- IT** Rispettare la corretta coppia di serraggio dei raccordi indicata a catalogo per ogni modello.
- EN** Respect the correct tightening torque of the fittings as specified in the catalogue for each model.
- DE** Das richtige Anziehdrehmoment der Anschlüsse, wie im Katalog für jedes Modell angegeben, beachten.
- FR** Respectez le couple de serrage correct des raccords comme indiqué dans le catalogue pour chaque modèle.
- ES** Respete el par de apriete de los racores indicado en el catálogo para cada modelo.
- PT** Respeitar o torque correto para cada conexão indicado no catalogo para cada modelo.

RIGHT

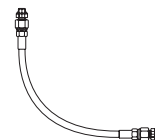
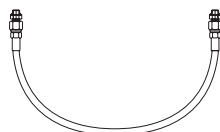

WRONG

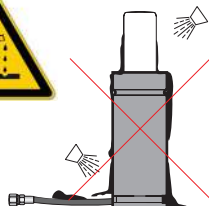
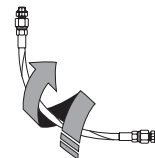

IT Evitare il contatto con solventi, acidi e fluidi aggressivi in genere (soda, cloruri) durante l'uso.

EN Avoid contact with solvents, acids and aggressive fluids in general (e.g. soda and chlorides) during use.

DE Bei Verwendung den Kontakt mit Lösungsmitteln, Säuren und aggressiven Flüssigkeiten im Allgemeinen (Soda, Chloride) vermeiden.

FR Évitez le contact avec les solvants, les acides et les fluides agressifs en général (par exemple, la soude et les chlorures) pendant l'utilisation.

ES Evite el contacto con disolventes, ácidos y fluidos agresivos en general (por ejemplo, soda y cloruros) durante el uso.

PT Evitar que tubos e conexões mantenham contato com oleos, solventes, acidos ou qualquer outro elemento agressivo aos materiais (ex. solda, cloro, etc..).

IT Verificare ad ogni manutenzione dello stampo lo stato dei tubi e in particolare:

- Assenza di deterioramento dei tubi dovuto a sfregamenti, corrosione, tagli o schiacciamenti.
- Posizione dei tubi come da progetto. - Corretto serraggio dei raccordi.

EN Check at each maintenance of the die the condition of the hoses and specifically:

- absence of hose deterioration due to rubbing, wear, cutting or crushing.
- positioning of the hoses corresponding to the project's specifications. - Correct tightening of the fittings.

DE Bei jeder Wartung des Werkzeugs den Zustand der Schläuche prüfen und insbesondere:

- keine Beschädigung der Schläuche durch Reibung, Korrosion, Schneiden, Quetschen.
- die Position der Schläuche entsprechend der Konstruktion. - Das richtige Anziehen der Anschlüsse.

FR Vérifiez à chaque entretien du moule l'état des tuyaux et plus précisément:

- absence de détérioration des tuyaux par frottement, usure, coupure ou écrasement.
- positionnement des tuyaux conforme aux spécifications du projet. - Serrage correct des raccords.

ES Compruebe el estado de las mangueras en cada mantenimiento del troquel, en particular:

- Ausencia de deterioro de las mangueras debido a roces, corrosión, cortes o aplastamientos.
- Posicionamiento de las mangueras según el proyecto. - Correcto apriete de los racores.

PT Verificar a cada manutenção do ferramental as condições das mangueiras e especificamente:

- Se as mangueiras não possuem nenhum dano, desgaste, corte ou fissura.
- Se as conexões estão nas mesmas posições indicadas no projeto. - Aperto correto das conexões.

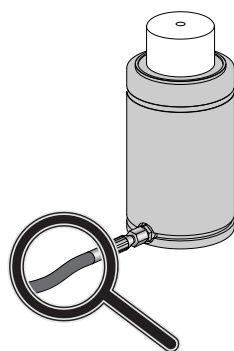

**LIFE
WARRANTY**

IT Se correttamente installati, utilizzati e non esposti a fattori di rischio, la durata in funzionamento di tubi e raccordi è attesa almeno pari a quella dei cilindri.

EN If correctly installed and used, without being exposed to risk factors, the expected lifetime of hoses and fittings is at least equal to the one of gas springs.

DE Bei sachgemäßem Einbau bzw. Anwendung und ohne Einwirken von Risikofaktoren wird erwartet, dass die Lebensdauer der Schläuche und Anschlüsse mindestens so lang ist wie die der Gasdruckfedern.

FR S'ils sont correctement installés et utilisés, sans être exposé à des facteurs de risque, la durée de vie attendue des tuyaux et des raccords est au moins égale à celle des ressorts à gaz.

ES Si están correctamente instalados, con un uso correcto y no expuestos a factores de riesgo, la vida útil de mangueras y racores debería ser al menos igual a la de los cilindros.

PT Se corretamente instalados e utilizados, a vida util das mangueiras e conexões são no mínimo a mesma vida util dos cilindros.



LINKED SYSTEM SELECTION

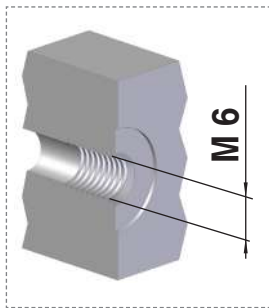

FLEXFLOW - CONNECTIONS
S12,65x1,5



TMA
Low gas flow



MICRO - CONNECTIONS
M8x1

Twin seal





TSM
Low gas flow



JIC 37° - CONNECTIONS
7/16"-20 UNF

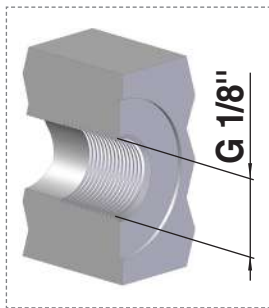

TNC
High gas flow



ORFS - CONNECTIONS
9/16"-18 UNF



HY 400
High gas flow



EO - 24° - CONNECTIONS
M12x1,5

Twin seal



HY 500
High gas flow



IT

- Pressa trasportabile con pompa pneumatica idraulica
- Idonea per raccordi dritti, 45° e 90°

EN

- Transportable press with hydraulic manual pump
- Suitable for straight, 45° and 90° fittings

DE

- Transportable Presse mit manueller Hydraulikpumpe
- Geeignet für gerade, 45° und 90° Anschlüsse

FR

- Presse transportable avec pompe oléodynamique manuelle
- Utilisable avec raccords droits, 45° et 90°

ES

- Prensa transportable con bomba oleodinámica manual
- Puede ser utilizada con tuberías derechas, 45° y 90°

PT

- Prensa transportável com bomba hidráulica manual
- Pode ser usado com tubos retos, 45° e 90°

code 39PR06



code 58UT022A (included)



IT Utensile rimuovi morsetti con calamita
EN Magnet tool to remove pressing jaws
DE Magnetwerkzeug für die Entfernung von Pressbacken
FR Outil magnétique pour enlever les mâchoires de pressage
ES Herramienta magnética para sacar las mordazas de la prensa
PT Ferramenta magnética para remover os mordentes de prensar

code 58UT001A (optional)



IT Forbice taglia tubo
EN Scissor for hose
DE Schlauchschneideschere
FR Ciseaux coupe-tube
ES Tijeras cortatubos
PT Tesouras corta tubos

code 58UT023A (optional)



IT Lampada led con magnete
EN LED Light with magnet
DE LED-Lampe mit Magnet
FR Lampe à LED magnétique
ES Lámpara LED con imán
PT Lâmpada LED com íman

AIR		L x P x H	Kg	°F °C
7 bar 110 psi	100 TON 110 US TON	380 x 430 x 400 mm 15 x 17 x 16 inch	38 kg 84 lb	-5 ÷ 40 °C 23 ÷ 104 °F

CONNECTIONS	ORFS "TSM" HOSE Ø 5,5 p. 288	Micro 32° - JIC 37° "TSM" HOSE Ø 5,5 p. 272 - 273	FlexFlow "TMA" HOSE Ø 5,1 p. 275	JIC 37° "TNB" HOSE Ø 8 p. 273	EO 24° "HY 500" HOSE Ø 11 p. 268	ORFS "HY 400" HOSE Ø 12,7 p. 284
PRESSING JAWS	code 39MTR10 (optional) 	code 39MTR11 (optional) 	code 39MTR12 (optional) 	code 39MTR13 (optional) 		

Ordering example: **39PR06A + 39MTR11** | Pressing jaws for Jic 37° "TNB" HOSE Ø 8,1

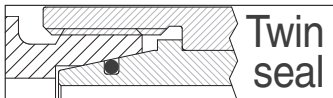

code 36HY50001...

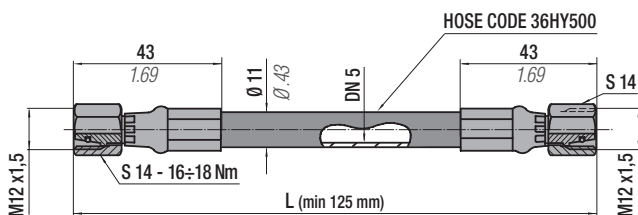

code 36HY50002...

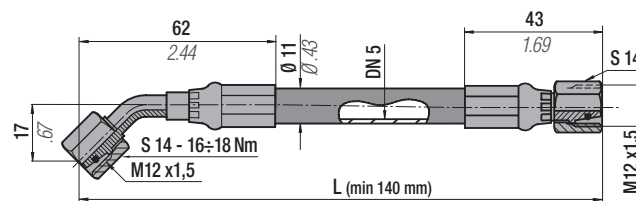

code 36HY50003...

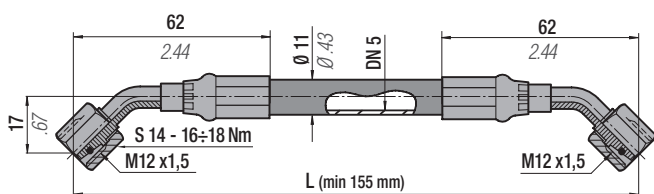

code 36HY50003...V1 ■

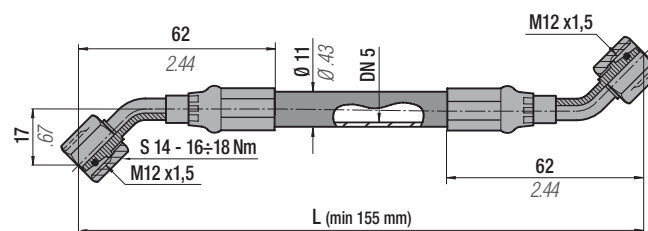

code 36HY50005...

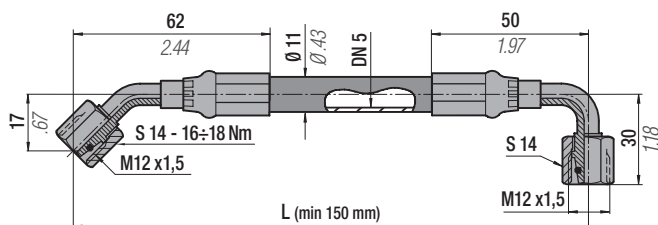

code 36HY50005...V1 ■

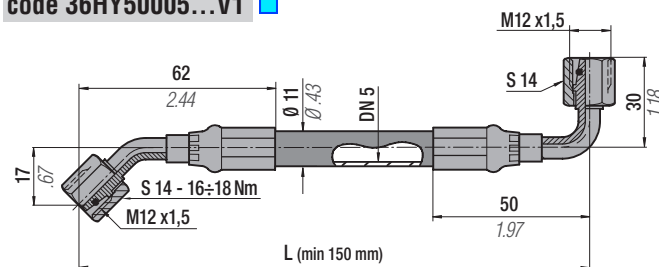

code 36HY50006...

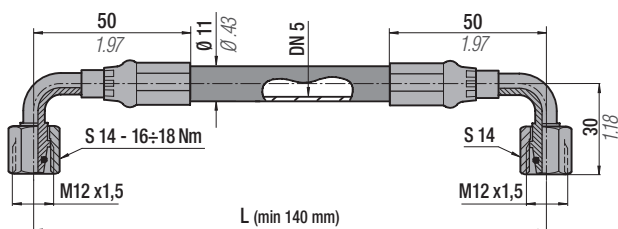

code 36HY50006...V1 ■

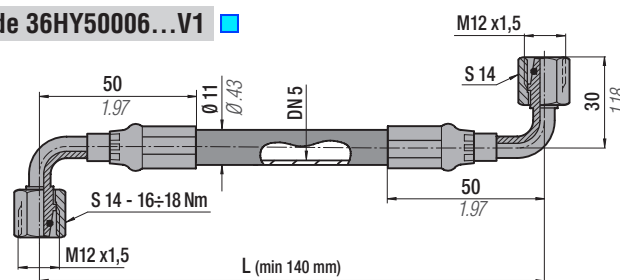

code 36HY50004...

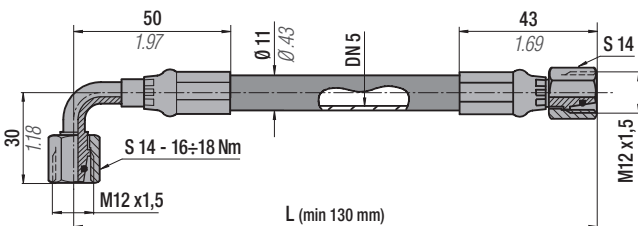



Lunghezza richiesta comprensiva di raccordi terminali
 Length upon request including end hose fittings
 Länge Anfrage einschließlich Ende Schlaucharmaturen
 Longueur requise, y compris des raccords d'extrémité
 Longitud requerida, incluyendo racores de los extremos
 Comprimento necessário incluindo todos os acessórios

Technical data				
"L" min	See each type	-	Volume	18 ml/metre
Operating pressure	345 bar	5003 psi	Dimension (hose)	3/16" (external \varnothing 11 mm)
Burst Pressure	1380 bar at 20°C	20010 psi at 68°F	Material (hose)	Thermoplastic
R (bending radius)	40 mm	1.57 in	Standard	SAE 100R8
Operating temperature	-40+ 100°C	-38+212°F	Outer case	Perforated

L = 5 mm upward increase - Example (36HY50001 0300; 36HY50001 0305; ...)

HOSE FITTINGS

code 36P2401

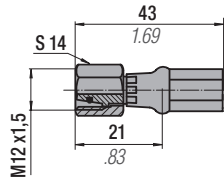

code 36P2402

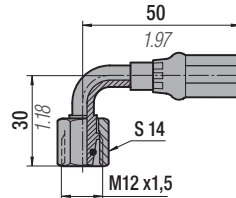

code 36P2403

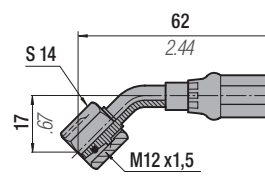

code 36FF11A

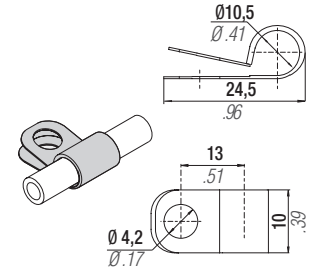

Raccordi tubo-cilindro/pannello - Hose-cylinder/panel connections - Anschlüsse zwischen schlauch und Zylinder/Kontrollarmatur -
 Raccords tuyau-cylindre/tableau - Racores manguera-cilindros/panel - Racord tubo-cilindro/panel

code 36R2401

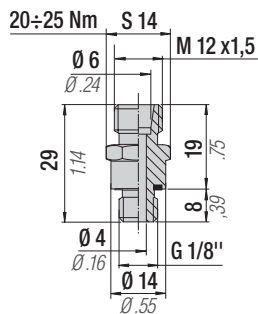

code 36R2402

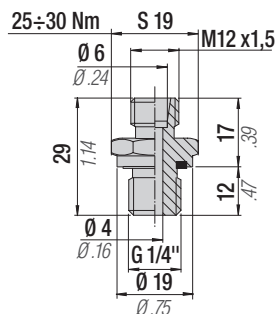

Raccordi di derivazione - Offtake connections - Anschlußstutzen - Raccords de dérivation - Racores de derivación - Racord de derivação

code 36R2403

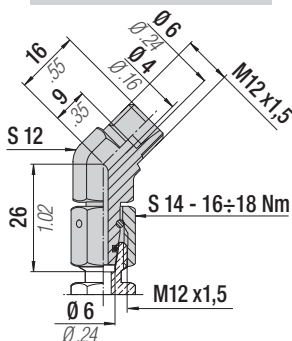

code 36R2404

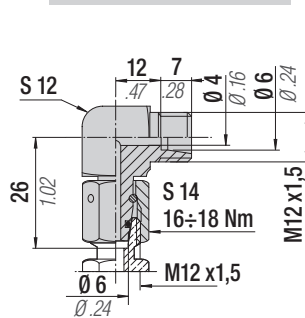

code 36R2405

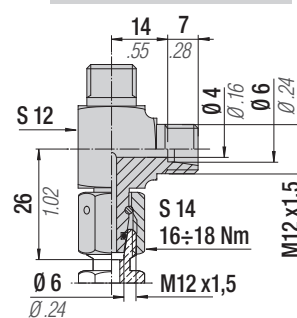

code 36R2406

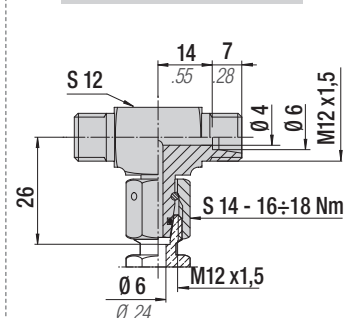

Raccordi tubo-tubo - Hose-hose connections - Anschlüsse zwischen Schlauch und Schlauch - Raccords tuyau-tuyau - Racores tubo-tubo - Racord tubo-tubo

code 36R2407

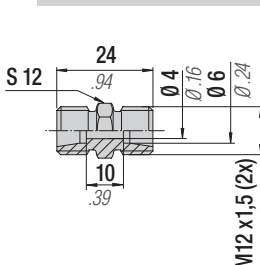

code 36R2408

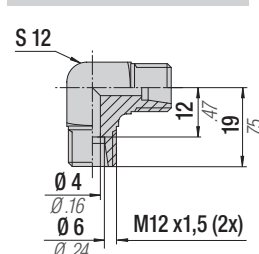

code 36R2409

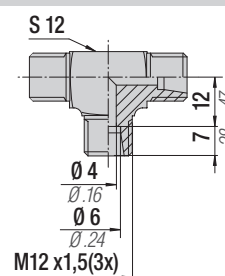

code 36R2410

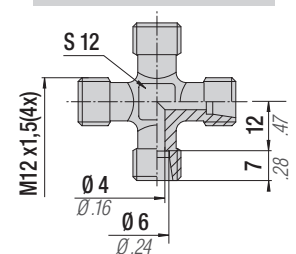

All dimensions in mm/inch

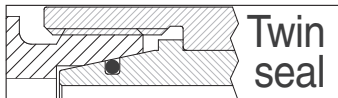

Esempi di installazione - Installation examples - Einbaubeispiele - Exemples de montage - Ejemplos de instalación - Exemplos de instalação

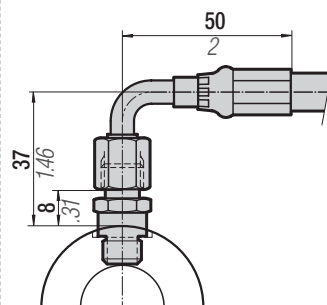
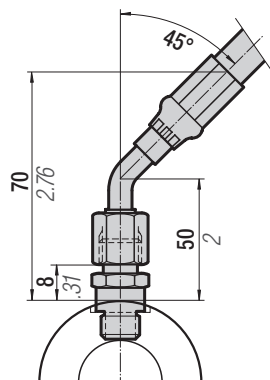
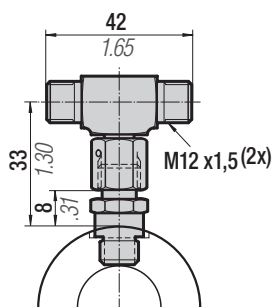
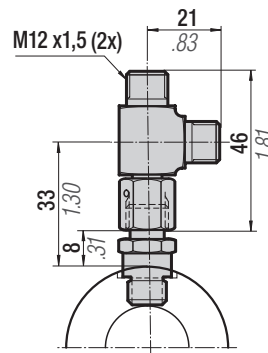
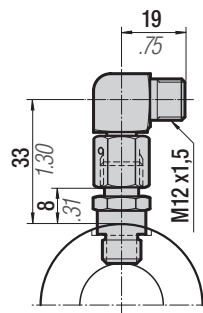
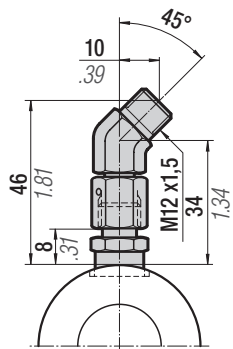
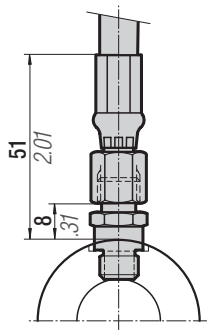



THIS PAGE IS INTENTIONALLY LEFT BLANK



code TNC 7/16...

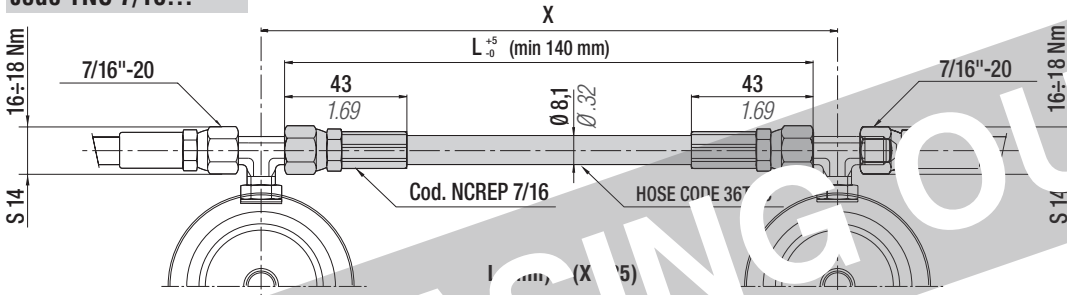

Technical data				
"L" min	See above	5.51 in	Volume	12,6 ml/metre
Operating pressure	45 bar	653 psi	Dimension (hose)	1/8" (external Ø 8,1 mm)
Burst Pressure	1655 bar at 20°C	24000 psi at 68°F	Material (hose)	Thermoplastic
R (bending radius)	25 mm	0.98 in	Standard	SAE 100R8
Operating temp.	-40+ 100°C	-38+212°F	Outer case	Perforated

Lunghezze standard (mm) inclusive di n. 2 raccordi NCREP 7/16
Standard lengths (mm) inclusive of no. 2 connections NCREP 7/16
Standard-Länge (mm) einsch. 2 NCREP 7/16-Anschlüssen
Longueur standard (mm) comprenant 2 raccords NCREP 7/16
Longitud estándar (mm) con 2 racores incluidos NCREP 7/16
Comprimento standard (mm) incluído nas 2 ligações NCREP 7/16

L = 5 mm upward increase
Example (TNC 7/16 140 mm; TNC 7/16 145 mm ...)

code TNB 7/16...

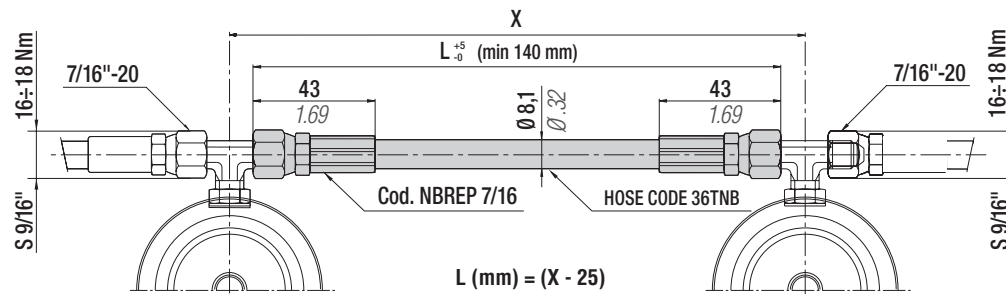

Technical data				
"L" min	See above	3.54 in	Volume	3 ml/metre
Operating pressure	45 bar	653 psi	Dimension (hose)	5/64" (external Ø 5,5 mm)
Burst Pressure	1655 bar at 20°C	24000 psi at 68°F	Material (hose)	Polyamide
R (bending radius)	13 mm	0.51 in	Outer case	Perforated
Operating temp.	-40+ 100°C	-38+212°F		

code: 36FF09A

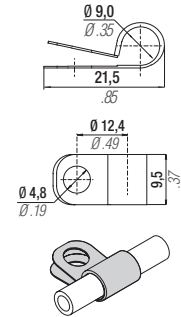

Lunghezze standard (mm) inclusive di n. 2 raccordi NBREP 7/16
Standard lengths (mm) inclusive of no. 2 connections NBREP 7/16
Standard-Länge (mm) einsch. 2 NBREP 7/16-Anschlüssen
Longueur standard (mm) comprenant 2 raccords NBREP 7/16
Longitud estándar (mm) con 2 racores incluidos NBREP 7/16
Comprimento standard (mm) incluído nas 2 ligações NBREP 7/16

L = 5 mm upward increase
Example (TNB 7/16 140 mm; TNB 7/16 145 mm ...)

CONNECTIONS JIC 37°

code TSM7/16...

Raccordi tubo-cilindro/pannello - Hose-cylinder/panel connections - Anschlüsse zwischen schlauch und Zylinder/Kontrollarmatur - Raccords tuyau-cylindre/tableau - Racores manguera-cilindros/panel - Racord tubo-cilindro/painel

code RTC-D

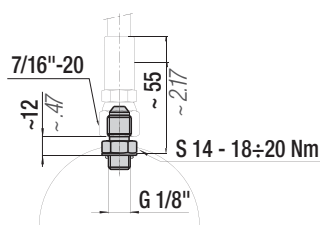

code RTC-M

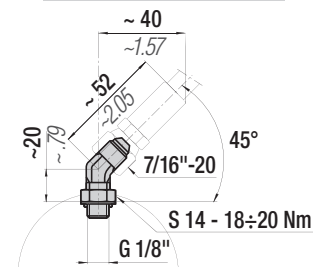

code RTC-R

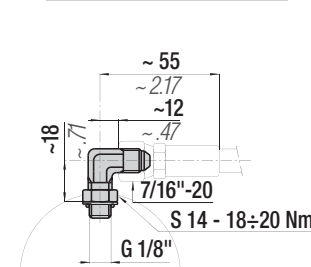

code RTC-L

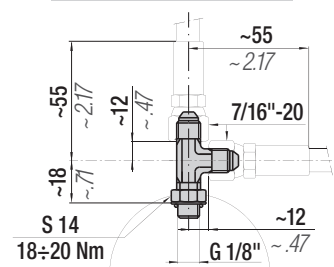

All dimensions in mm/inch

code RTC-T

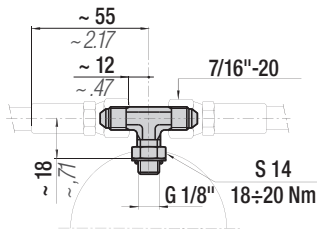

code 36J01A

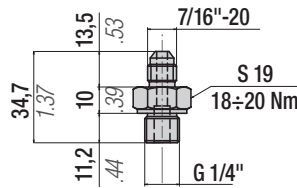

Raccordi di derivazione - Offtake connections - Anschlußstutzen - Raccords de dérivation - Racores de derivación - Racord de derivação

code RDR

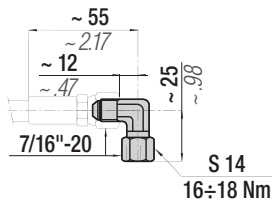

code RDT

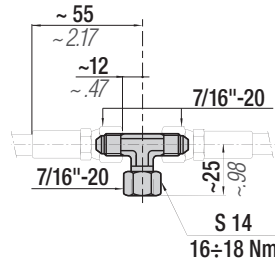

code RDM

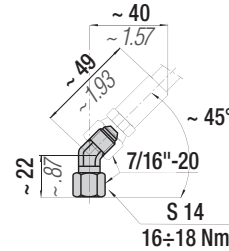

code RDL

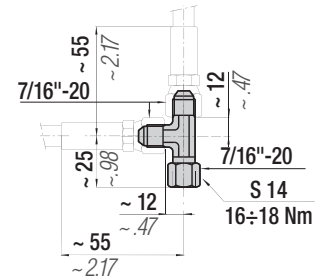

Raccordi tubo-tubo - Hose-hose connections - Anschlüsse zwischen Schlauch und Schlauch - Raccords tuyau-tuyau - Racores tubo-tubo - Racord tubo-tubo

code RTT-D

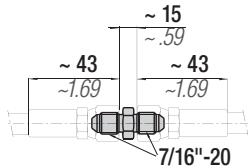

code RTT-R

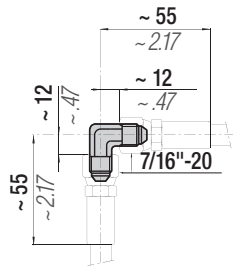

code RTT-T

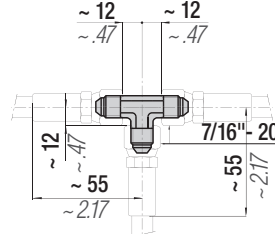

code RTT-C

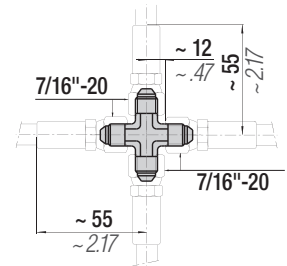

JIC 37° Hose Ø 5,5 mm

TSM

code TSM7/16...

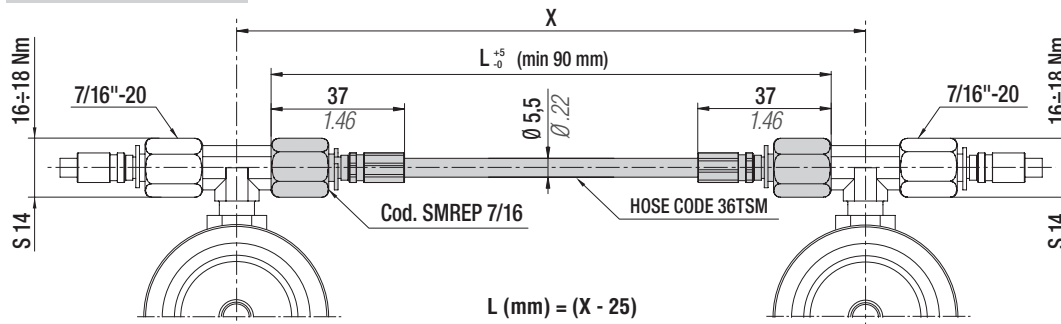

code: 36FF06A

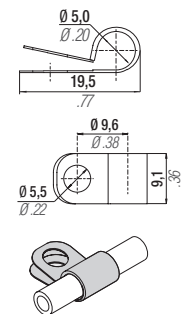

Technical data				
"L" min	See above	3.54 in	Volume	3 ml/metre
Operating pressure	630 bar	9135 psi	Dimension (hose)	5/64" (external Ø 5,5 mm)
Burst Pressure	1890 bar at 20°C	27400 psi at 68°F	Material (hose)	Thermoplastic
R (bending radius)	20 mm	0.79 in	Standard	-
Operating temp.	-40+ 100°C	-38 +212°F	Outer case	Perforated



Lunghezza standard (mm) inclusive di n. 2 raccordi SMREP 7/16
Standard lengths (mm) inclusive of no. 2 connections SMREP 7/16
Standard-Länge (mm) einsch. 2 SMREP 7/16 - Anschlüssen
Longueur standard (mm) comprenant 2 raccords SMREP 7/16
Longitud estándar (mm) con 2 racores incluidos SMREP 7/16
Comprimento standard (mm) incluído nas 2 ligações SMREP 7/16

L = 5 mm upward increase - Example (TSM 7/16 90 mm; TSM 7/16 100 mm ...)

All dimensions in mm/inch

code TMD

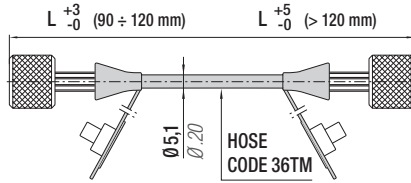

code TMD...-1

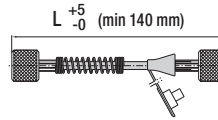

code TMD...-2

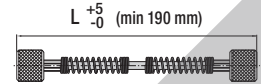

code TMDR

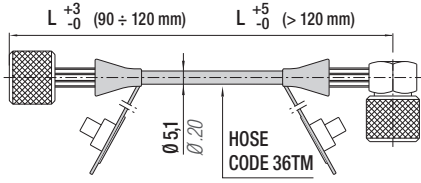

code TMDR...-1

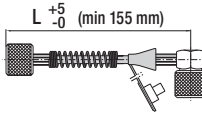

code TMDR...-3

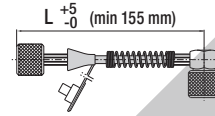

code TMDR...-2

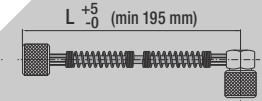

code TMR

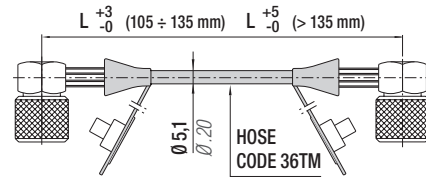

code TMR...-3

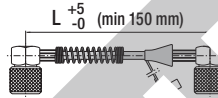

code TMR...-2

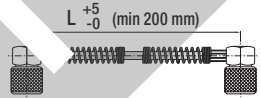

code TMR...V1

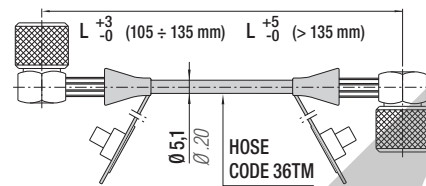

code TMR...V1-3

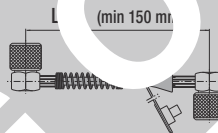

code TMR...V1-2

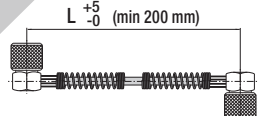

code TMR...V2

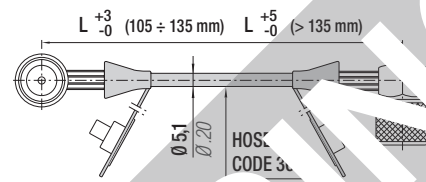

code TMR...V2-3

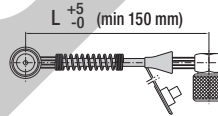

code TMR...V2-2

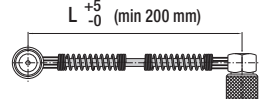

code TMR...V3

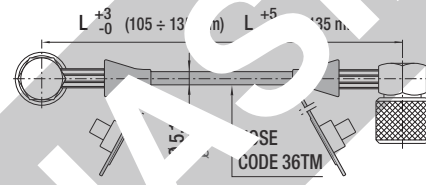

code TMR...V3-3

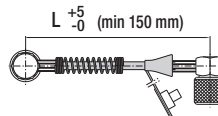

code TMR...V3-2

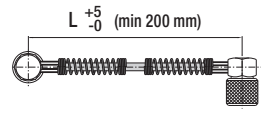

Technical data

"L" min (TMD - TMDR)	see above	-	Operating temp.	-20 +100°C	-2 +212°F
"L" min (TMR - TMR...)	see above	-	Dimension (hose)	5/64" (external ø 5,1 mm)	
Operating press.	630 bar	9135 psi	Material (hose)	Polyamid	
Burst Pressure	1950 bar at 20°C	28275 psi at 68°F	Standard	-	
R (bending radius)	20 mm	0.79 in	Outer case hose	Perforated	



Lunghezze standard (mm) inclusive di n.2 raccordi e tappi
Standard lengths (mm) inclusive of no.2 connections and plugs
Standard-Länge (mm) einsch.2 und Stopfen Anschlüssen

Longueur standard (mm) comprenant 2 raccords et bouchons
Longitud estándar (mm) con 2 racores incluidos y tapones
Comprimento standard (mm) incluindo nas 2 ligações e tampões

standard L = 90 ÷ 120 mm min. - 1 mm upward increase

Example (TMD91; TMD119; TMR107; TMR114V1; ...)

standard L = > 120 mm min. - 5 mm upward increase

Example (TMD120; TMD125; TMR135; TMR150V1; ...)

HOSE FITTINGS

code 36MREPD

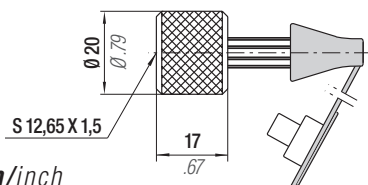

code 36MREPR

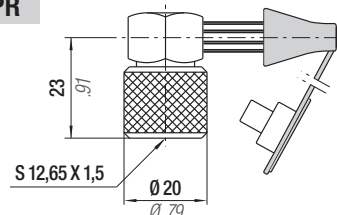

All dimensions in mm/inch

code TMAD

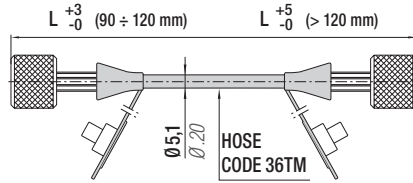
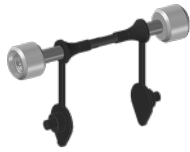

code TMAD...-1

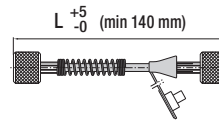

code TMAD...-2

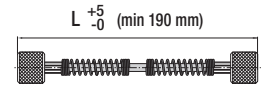

code TMADR

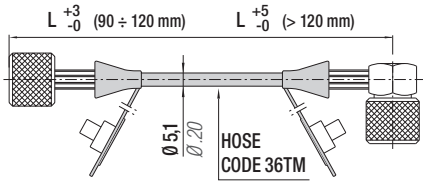
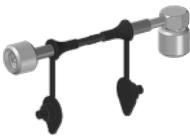

code TMADR...-1

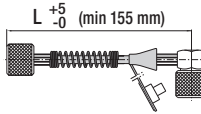

code TMADR...-3

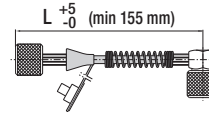

code TMADR...-2

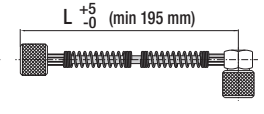

code TMAR

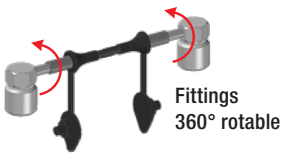

Examples of rotated fittings:

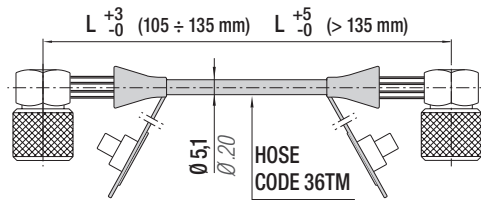
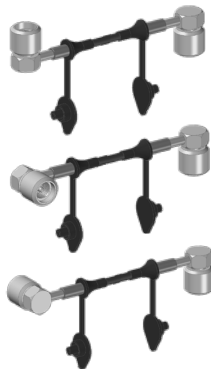

code TMAR...-3

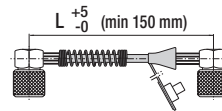

code TMAR...-2

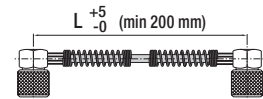

Examples of rotated fittings:



Technical data				
"L" min	See above	-	Dimension (hose)	5/64" (external Ø 5,1 mm)
Operating pressure	630 bar	9135 psi	Material (hose)	Polyamide
Burst Pressure	1950 bar at 20°C	28275 psi at 68°F	Material (fitting)	Stainless Steel
R (bending radius)	20 mm	0.79 in	Standard	-
Operating temp.	-20 +100°C	-2 +212°F	Outer case	Perforated

! Lunghezze standard (mm) inclusive di n.2 raccordi e tappi
Standard lengths (mm) inclusive of no.2 connections and plugs
Standard-Länge (mm) einsch.2 und Stopfen Anschlüssen

Longueur standard (mm) comprenant 2 raccords et bouchons
Longitud estándar (mm) con 2 racores incluidos y tapones
Comprimento standard (mm) incluído nas 2 ligações e tampões

standard **L** = 90 ÷ 120 mm min. - 1 mm upward increase
Example (TMAD91; TMAD119; TMAR107; TMAR114; ...)

standard **L** = > 120 mm min. - 5 mm upward increase
Example (TMAD120; TMAD125; TMAR135; TMAR150; ...)

HOSE FITTINGS

code 36MREPDA

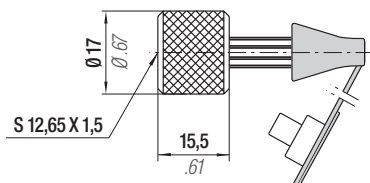

code 36MREPR

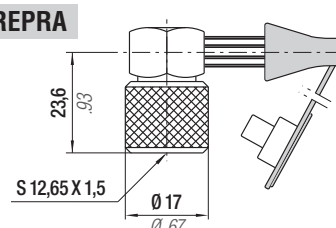

code: 59MTM

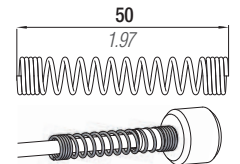

Protezione antipliega
Anti-kink protection
Knickschutzwendel
Protection anti-croquage
Protección anti-pliegue
Proteção anti-dobra

code: 36FF06A

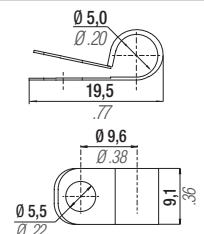

All dimensions in mm/inch



THIS PAGE IS INTENTIONALLY LEFT BLANK



Raccordi tubo-cilindro/pannello - Hose-cylinder/panel connections - Anschlüsse zwischen schlauch und Zylinder/Kontrollarmatur -
Raccords tuyau-cylindre/tableau - Racores manguera-cilindros/panel - Racord tubo-cilindro/painel

code 39BDM0901

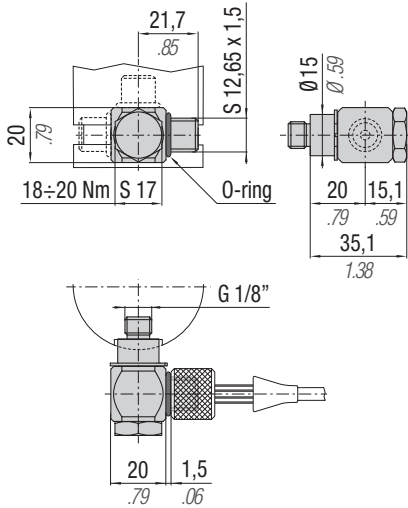

code 39BDM0902

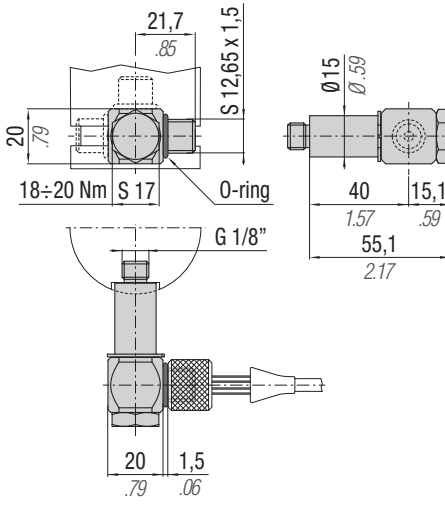

code 39BDM1001

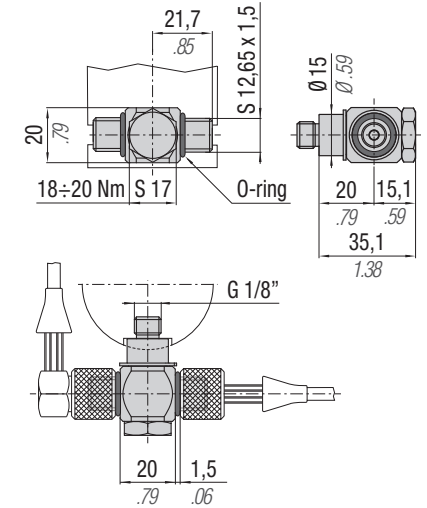

code 39BDM1002

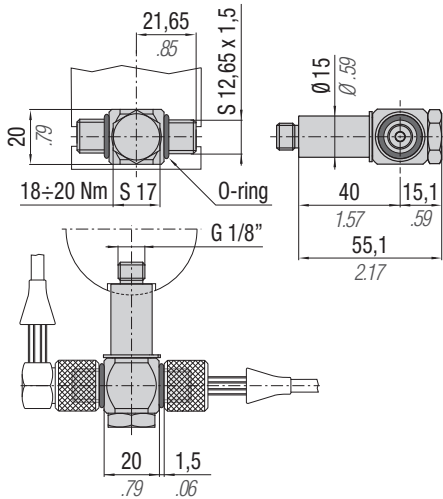

Bloccetto di distribuzione - Distribution block - Gasverteilstück - Plot de distribution - Bloque de distribución -
Bloco de distribuição

code 39BDM1101

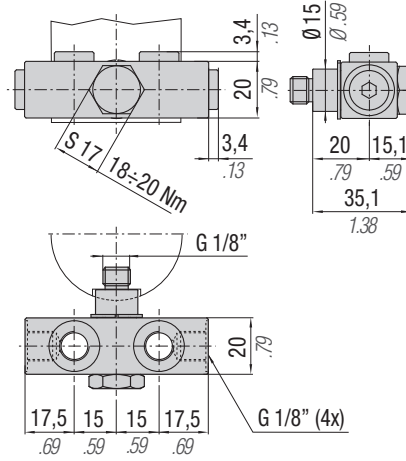

code 39BDM1102

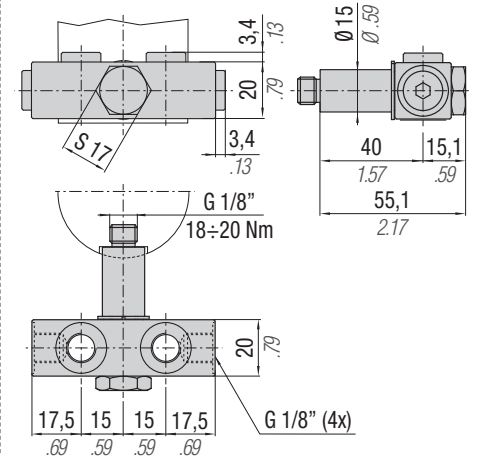

Raccordi tubo-cilindro/pannello - Hose-cylinder/panel connections - Anschlüsse zwischen schlauch und Zylinder/Kontrollarmatur -
Raccords tuyau-cylindre/tableau - Racores manguera-cilindros/panel - Racord tubo-cilindro/painel

code 39BDM1201

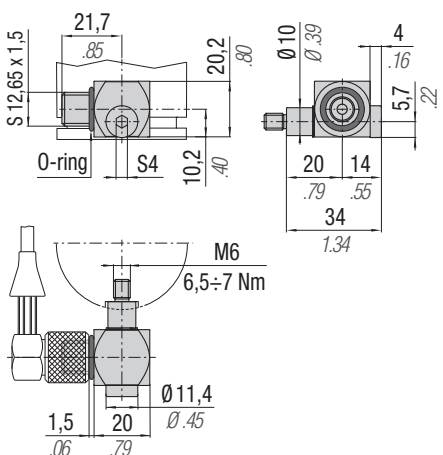

code 39BDM1202

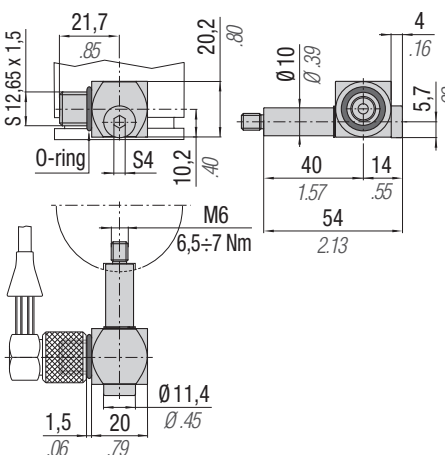

code 39BDM1301

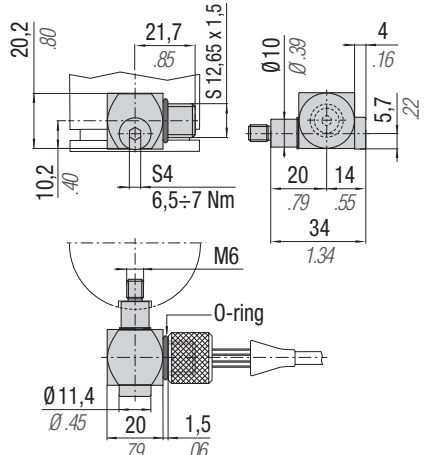

All dimensions in mm/inch

code 39BDM1302

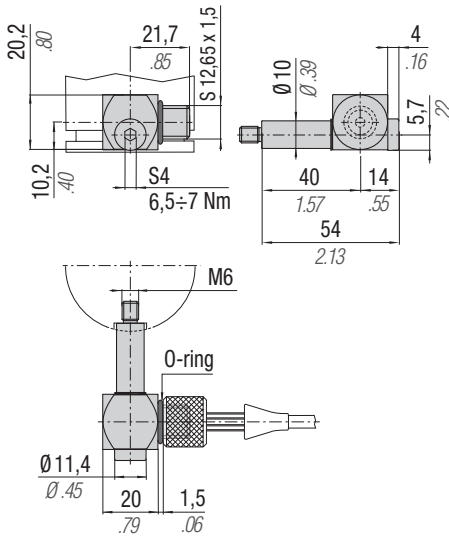

code 39BDM1401

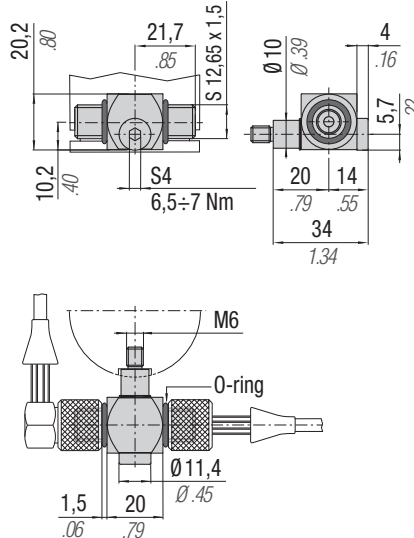

code 39BDM1402

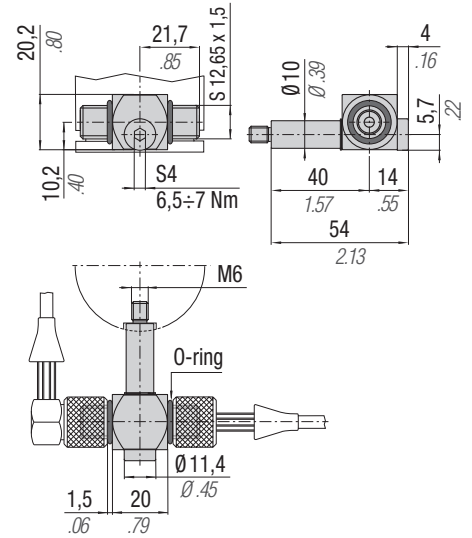

code 39BDM1601

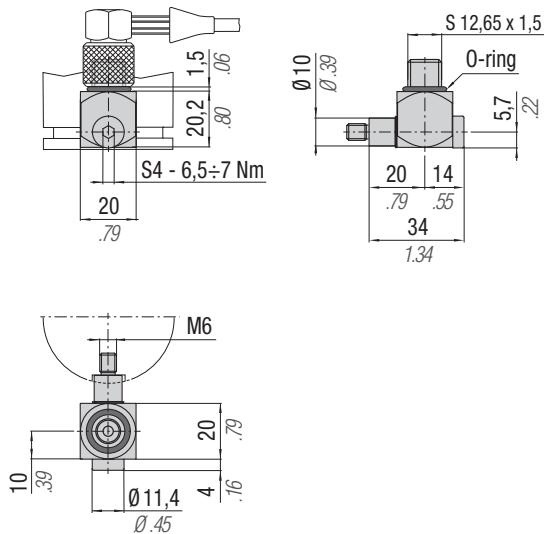

code 39BDM1602

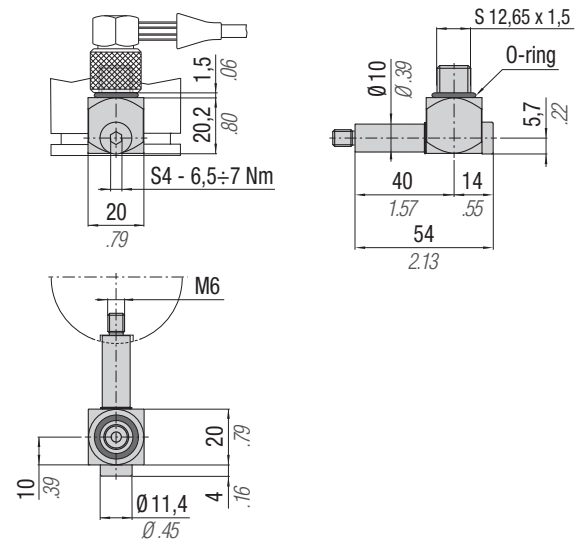

Blocchetto di distribuzione - Distribution block - Gasverteilstück - Plot de distribution - Bloque de distribución - Bloco de distribuição

code 39BDM1501

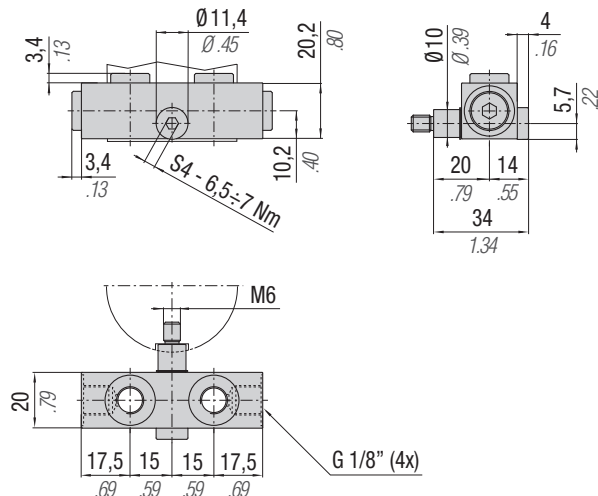

code 39BDM1502

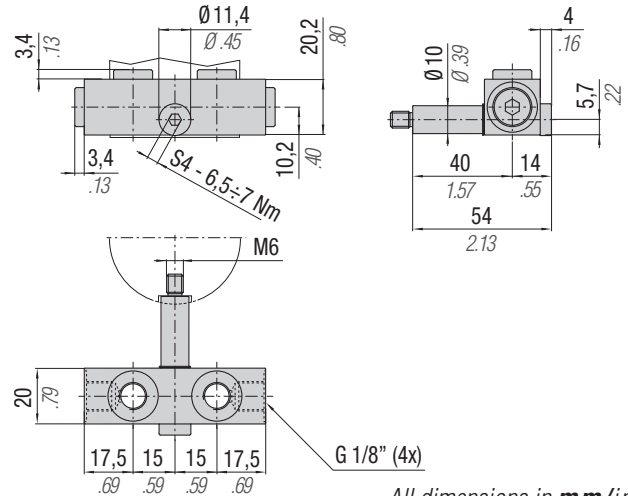

All dimensions in mm/inch



code TSM01A...

code: 36FF06A

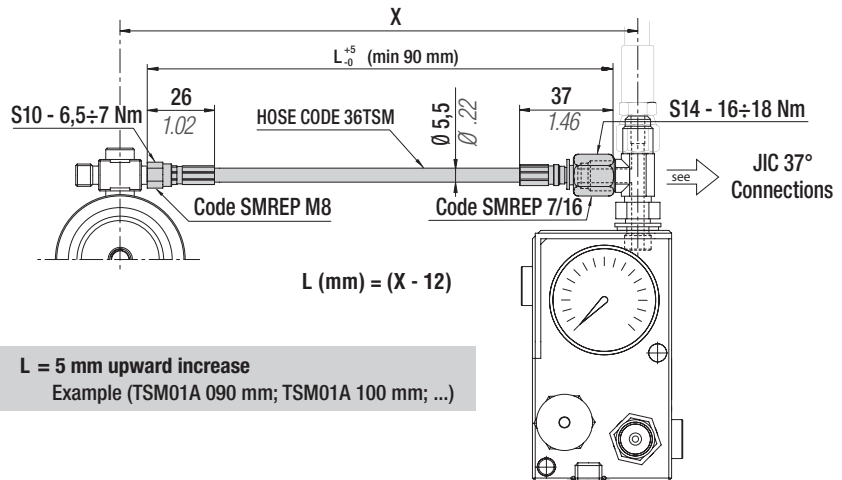
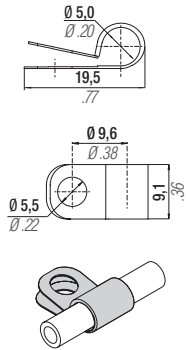

Technical data				
"L" min	See each type	3.54 in	Volume	3 ml/metre
Operating pressure	630 bar	9135 psi	Dimension (hose)	5/64" (external ø 5,5 mm)
Burst Pressure	1890 bar at 20°C	27400 psi at 68°F	Material (hose)	Thermoplastic
R (bending radius)	20 mm	0.79 in	Standard	-
Operating temp.	-40 +100°C	-38 +212°F	Outer case	Perforated



Lunghezze standard (mm) inclusive di n. 1 raccordo SMREP M8 e n. 1 raccordo SMREP 7/16.
 Standard lengths (mm) inclusive of no. 1 SMREP M8 connector and no. 1 SMREP 7/16 connector.
 Standard-Länge (mm) einschl. 1 SMREP M8-Anschlussstück und 1 SMREP 7/16-Anschlussstück.

Longueurs standard (mm) comprenant 1 raccord SMREP M8 et 1 raccord SMREP 7/16.
 Longitudes estándar (mm) con 1 racor SMREP M8 y 1 racor SMREP 7/16.
 Comprimentos standard (mm) incluido 1 ligação SMREP M8 e 1 ligação SMREP 7/16.

MICRO 32° and FLEXFLOW Hose Ø 5,1 mm

code 36TMA01A...

code: 36FF06A

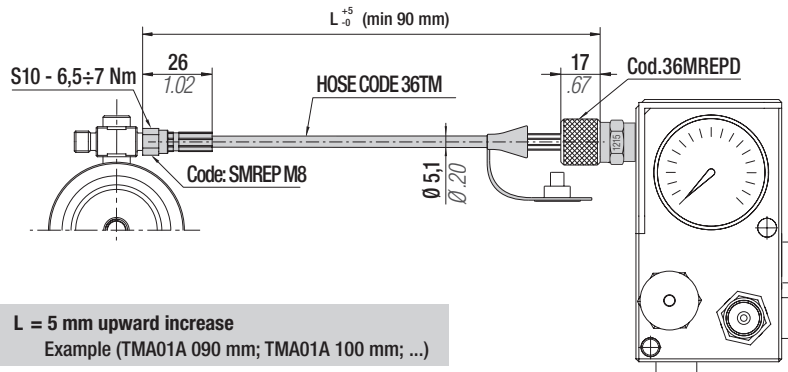
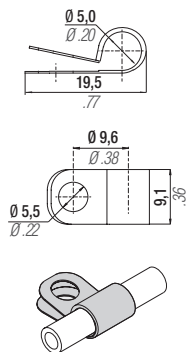

Technical data				
"L" min	See each type	-	Volume	3 ml/metre
Operating pressure	630 bar	9135 psi	Dimension (hose)	5/64" (external ø 5,1 mm)
Burst Pressure	1950 bar at 20°C	28275 psi at 68°F	Material (hose)	Polyamide
R (bending radius)	20 mm	0.79 in	Standard	-
Operating temp.	-20 +100°C	-2 +212°F	Outer case hose	Perforated



Lunghezze standard (mm) inclusive di n.2 raccordi e tappi
 Standard lengths (mm) inclusive of no.2 connections and plugs
 Standard-Länge (mm) einschl.2 und Stopfen Anschlüssen

Longueur standard (mm) comprenant 2 raccords et bouchons
 Longitud estándar (mm) con 2 racores incluidos y tapones
 Comprimento standard (mm) incluido nas 2 ligações e tampões



All dimensions in mm/inch

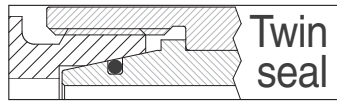

Raccordi tubo-cilindro/pannello - Hose-cylinder/panel connections - Anschlüsse zwischen schlauch und Zylinder/Kontrollarmatur -
Raccords tuyau-cylindre/tableau - Racores manguera-cilindros/panel - Racord tubo-cilindro/painel

code MT

(only M 50, M70, M90, M90 TBM, M90 TEM, M90 TBI, M200 RV 170 - 320 rev.C)

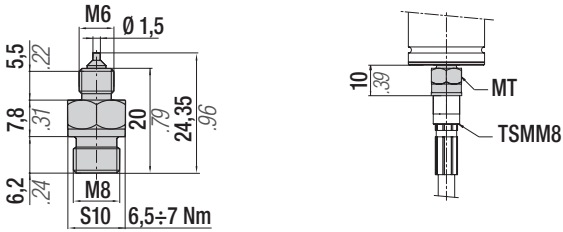

code MB

(only M 50, M70, M90, M90 TBM, M90 TEM, M90 TBI, M200 RV 170 - 320 rev.C)

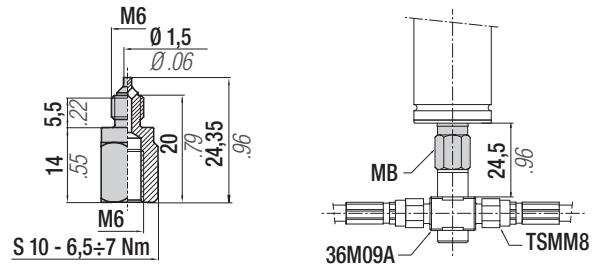

code RSMTCD

S 10 - 6.5±7 Nm

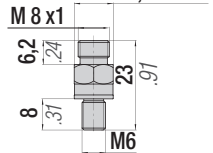

code 36M08B

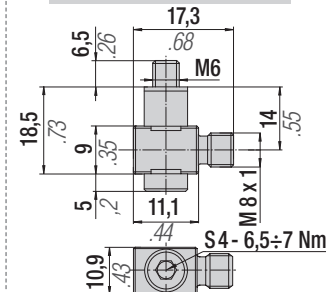

code 36M09B

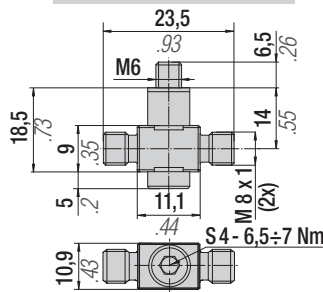

code 36M10C

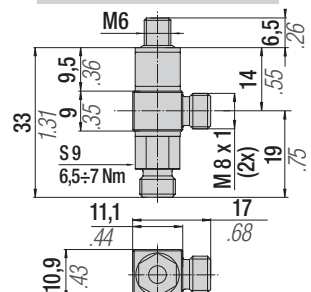

code 36M11C

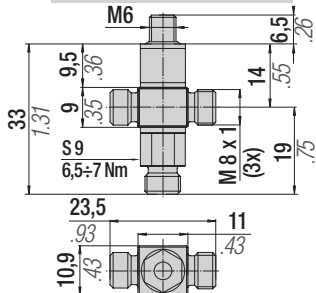

code RSMPD

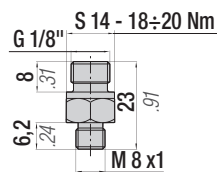

code 36M03A

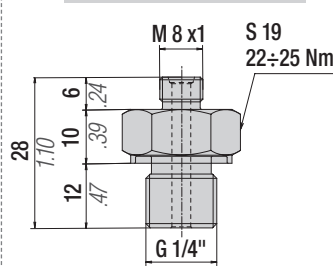

code 36M22A

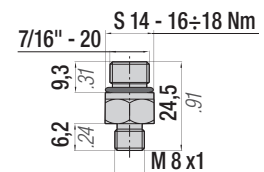

Raccordi di derivazione - Offtake connections - Anschlußstutzen - Raccords de dérivation - Racores de derivación - Racord de derivação

code 36M02A

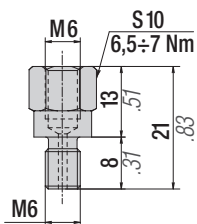

code 36M04A

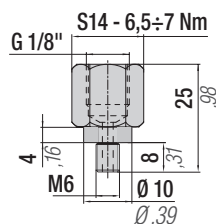

code 36MTC

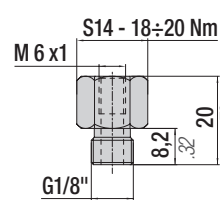

code 36MTR

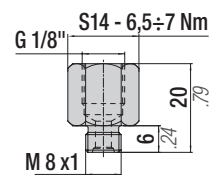

code 36M01A

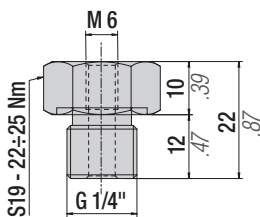

code 36M12A

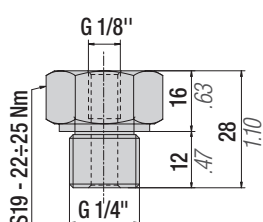

code 36M21A

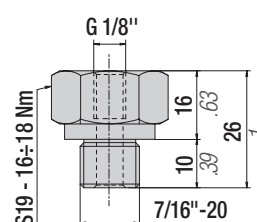

All dimensions in mm/inch

Raccordi tubo-tubo - Hose-hose connections - Anschlüsse zwischen Schlauch und Schlauch - Raccords tuyau-tuyau - Racores tubo-tubo - Racord tubo-tubo

code 36MTTD

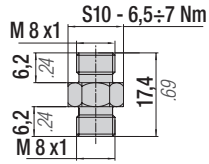

code 36RTTJM

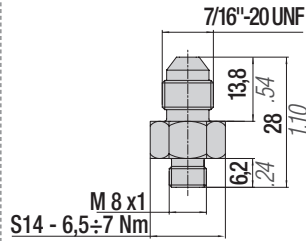

code 36M05A

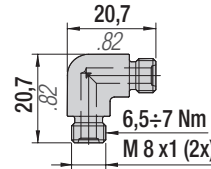

code 36M06A

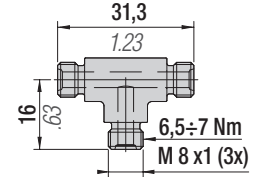

code 36M07A

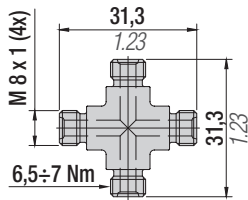

MICRO 32° HEAVY DUTY STAINLESS STEEL CONNECTIONS

Raccordi tubo-cilindro/pannello - Hose-cylinder/panel connections - Anschlüsse zwischen schlauch und Zylinder/Kontrollarmatur - Raccords tuyau-cylindre/tableau - Conexiones sistema de cilindros/panel - Racord tubo-cilindro/panel

code 36M15A

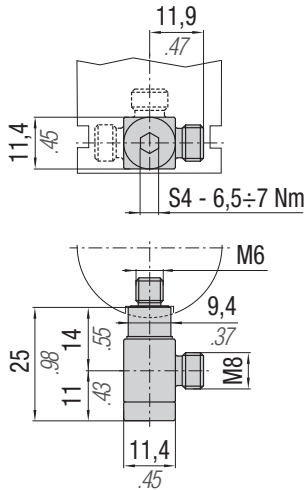

code 36M16A

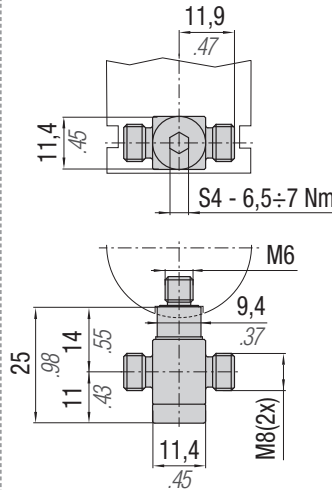

code 36M17A

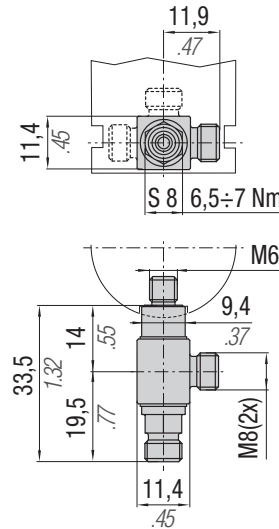

code 36M18A

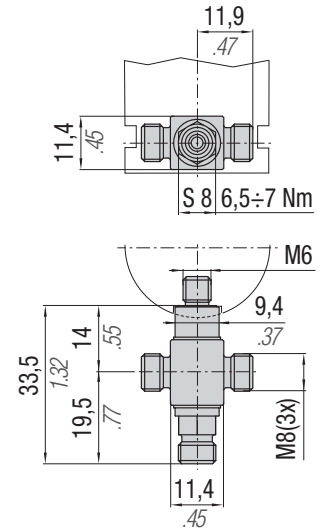

code 36HY40016...

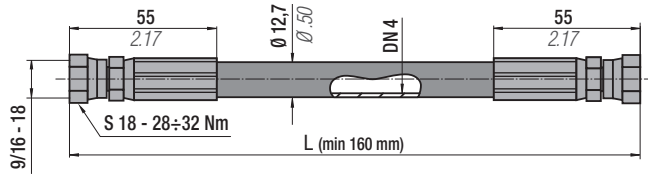

code 36HY40022...

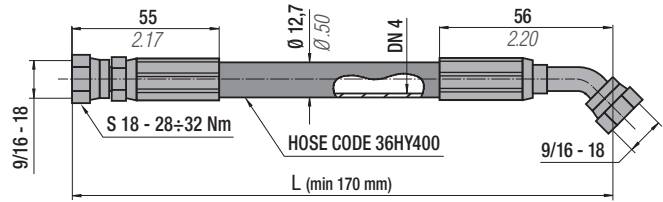

code 36HY40020...

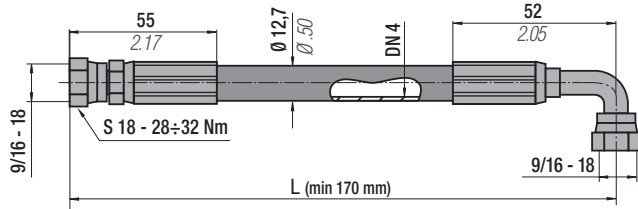

code 36HY40021...

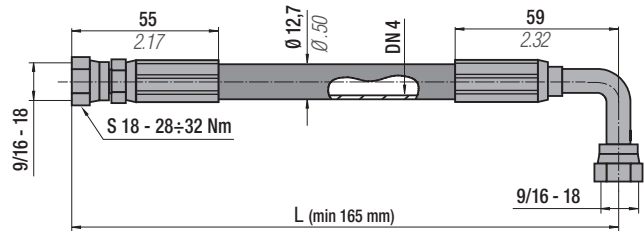

code 36HY40017...

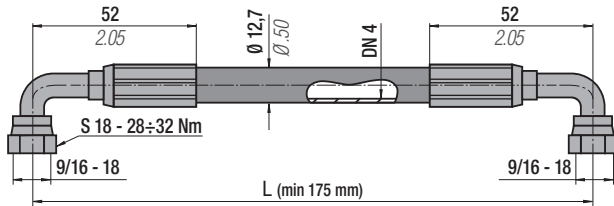

code 36HY40017...V1

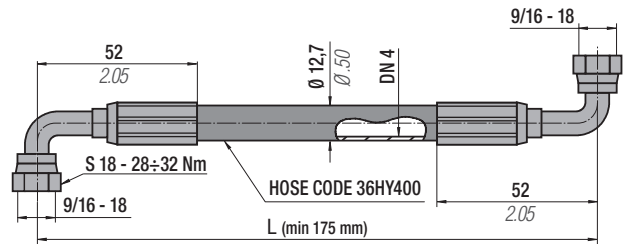

code 36HY40025...

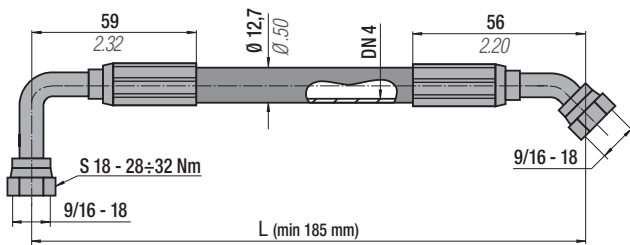

code 36HY40025...V1

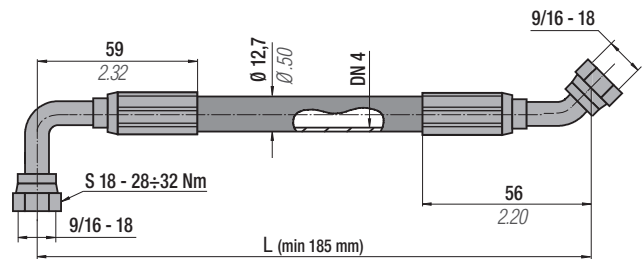

code 36HY40018...

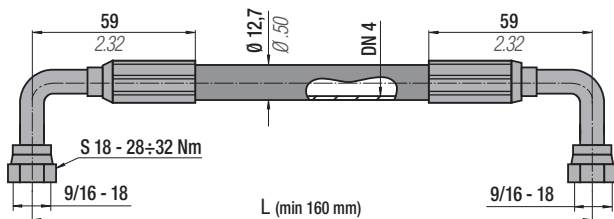

code 36HY40018...V1

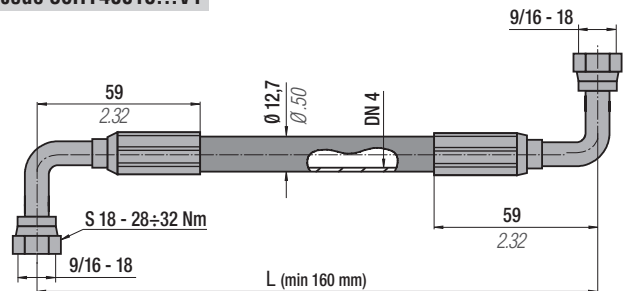

All dimensions in mm/inch

code 36HY40019...

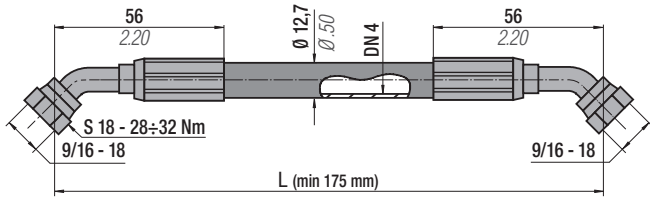

code 36HY40019...V1

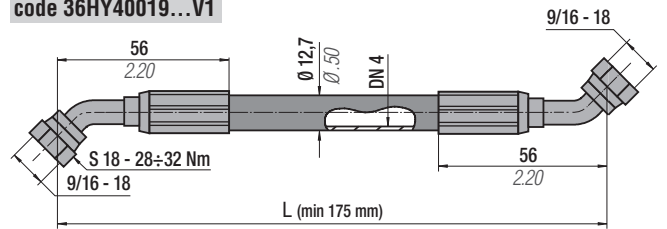

code 36HY40023...

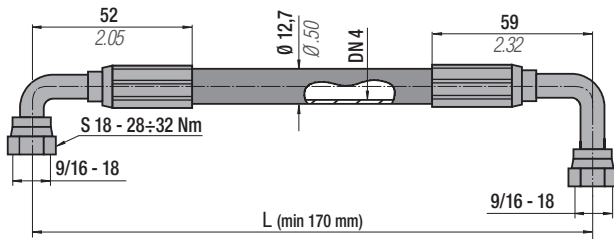

code 36HY40023...V1

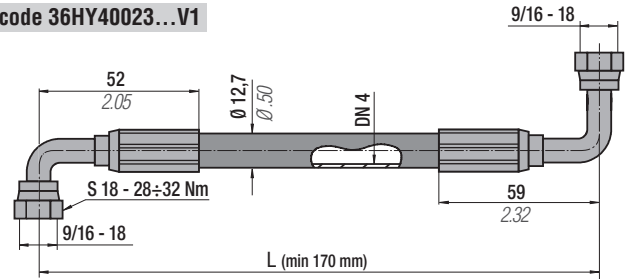

code 36HY40024...

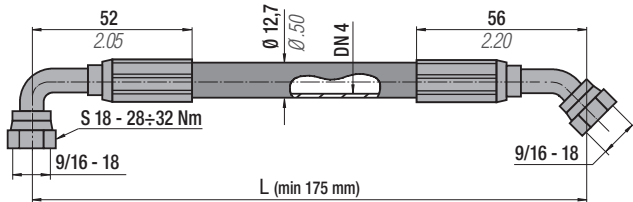

code 36HY40024...V1

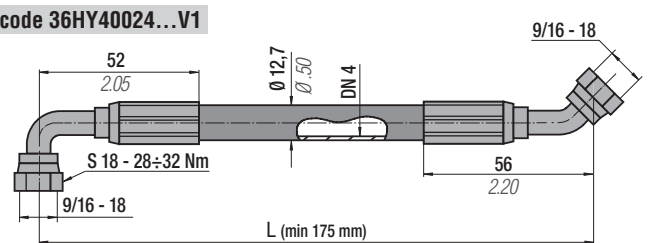

code 36HY40026...

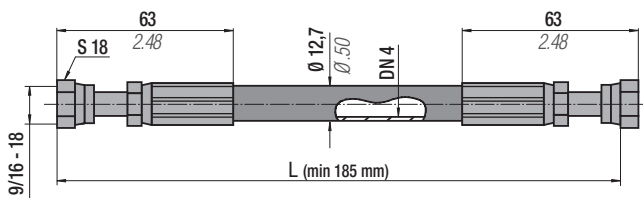

code 36HY40027...

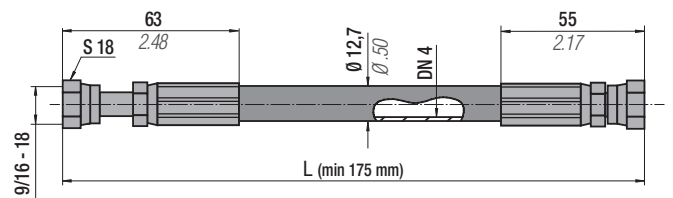

code 36HY40028...

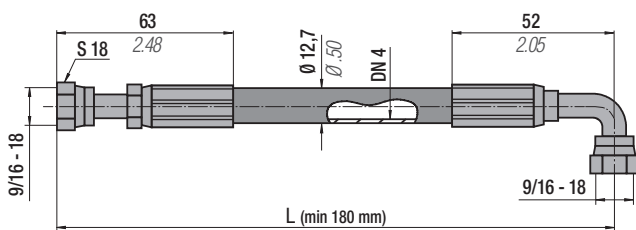

code 36HY40029...

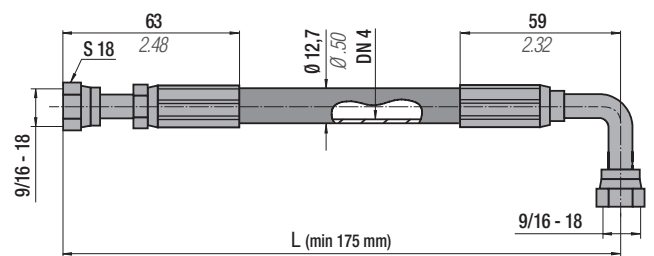

code 36HY40030...

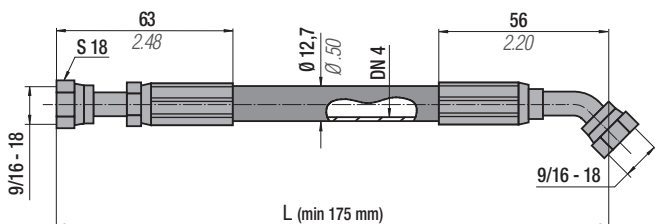

code: 36FF13A

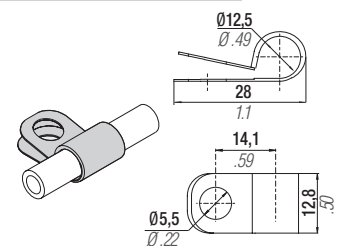

Technical data				
"L" min	See each type	-	Volume	32 ml/metre
Operating pressure	345 bar	5003 psi	Dimension (hose)	1/4" (external Ø 12,7 mm)
Burst Pressure	1380 bar at 20°C	20010 psi at 68°F	Material (hose)	Thermoplastic
R (bending radius)	51 mm	2.01 in	Standard	SAE 100R8
Operating temperature	-40+ 100°C	-38 +212°F	Outer case	Perforated



Lunghezza richiesta comprensiva di raccordi terminali
 Length upon request including end hose fittings
 Länge Anfrage einschließlich Ende Schlaucharmaturen
 Longueur requise, y compris des raccords d'extrémité
 Longitud requerida, incluyendo racores de los extremos
 Comprimento necessário incluindo todos os acessórios

L = 5 mm upward increase - Example (36HY40016 0300; 36HY40016 0305; ...)

HOSE FITTINGS

code 36P9/1604

Straight Swivel

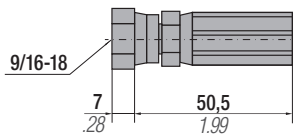

code 36P9/1605

Straight Long Swivel

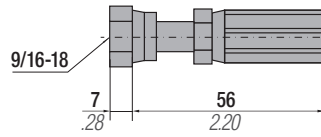

code 36P9/1606

90° Long Swivel

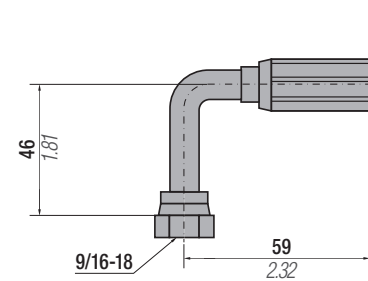

code 36P9/1607

90° Swivel

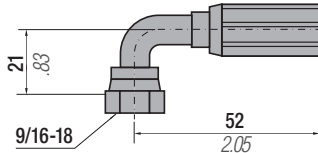

code 36P9/1608

45° Swivel

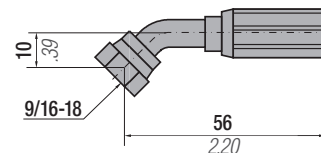



THIS PAGE IS INTENTIONALLY LEFT BLANK



code 36TSM9/1601...

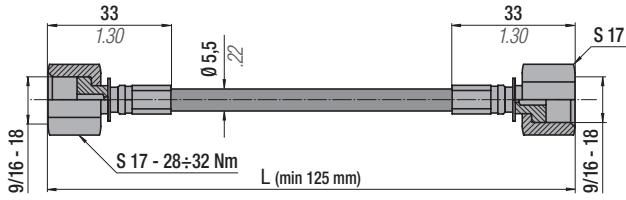

code 36TSM9/1602...

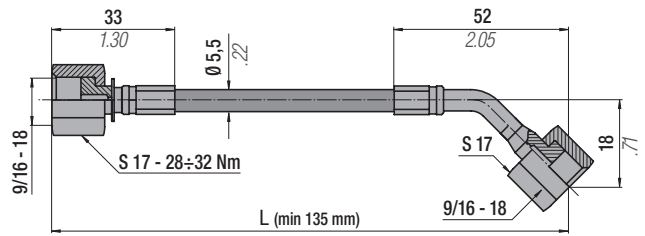

code 36TSM9/1603...

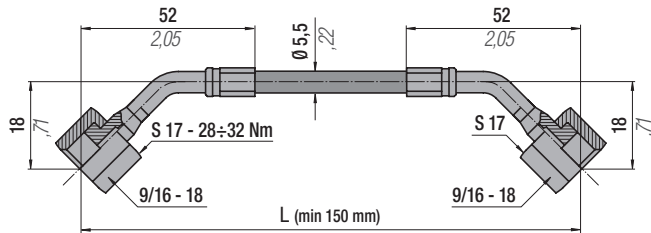

code 36TSM9/1603...V1

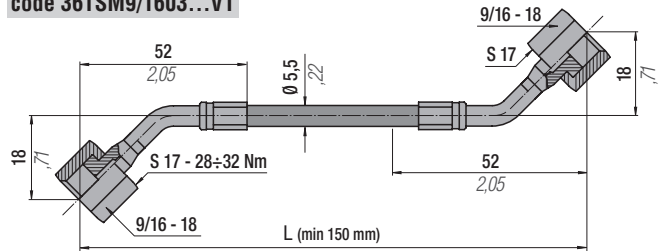

code 36TSM9/1605...

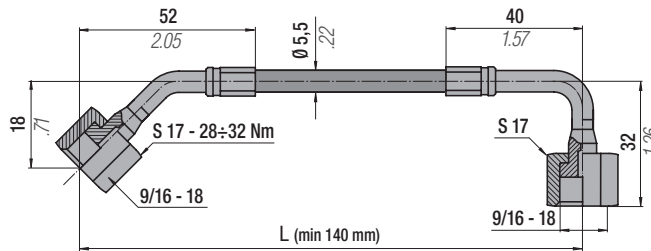

code 36TSM9/1605...V1

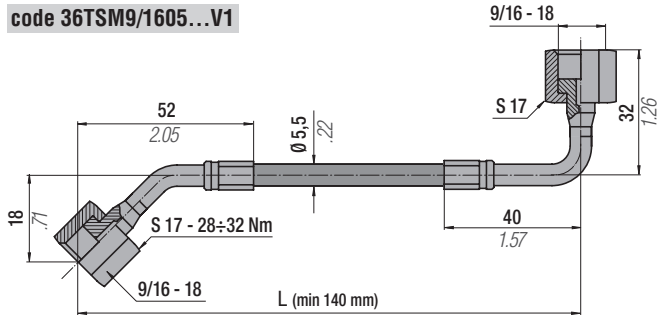

code 36TSM9/1606...

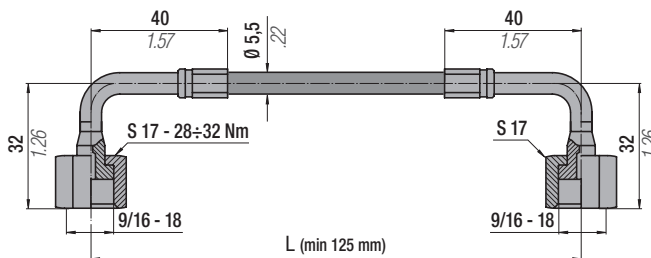

code 36TSM9/1606...V1

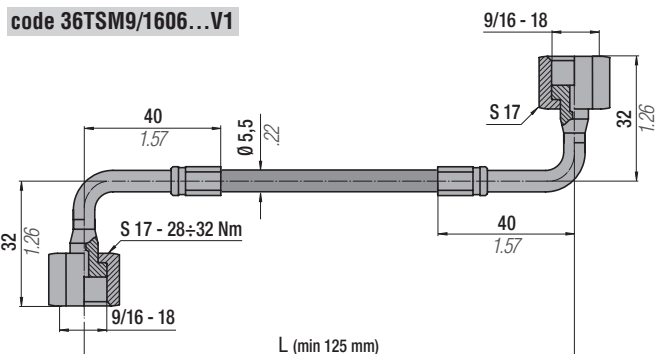

code 36TSM9/1604...

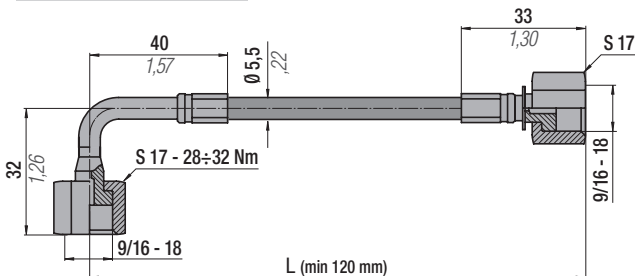

code: 36FF06A

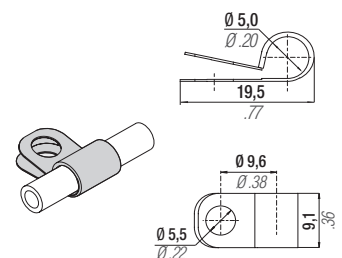

Technical data				
"L" min	See each type	-	Volume	3 ml/metre
Operating pressure	630 bar	9135 psi	Dimension (hose)	5/64" (external Ø 5,5 mm)
Burst Pressure	1890 bar at 20°C	27400 psi at 68°F	Material (hose)	Thermoplastic
R (bending radius)	20 mm	0,79 in	Standard	-
Operating temperature	-40+ 100°C	-38 +212°F	Outer case	Perforated



Lunghezza richiesta comprensiva di raccordi terminali
Length upon request including end hose fittings
Länge Anfrage einschließlich Ende Schlaucharmaturen
Longueur requise, y compris des raccords d'extrémité
Longitud requerida, incluyendo racores de los extremos
Comprimento necessário incluindo todos os acessórios

L = 5 mm upward increase - Example (36TSM9/1601 0300; 36TSM9/1605 0310; ...)

HOSE FITTINGS

code 36P9/1601

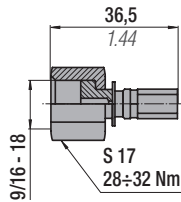

code 36P9/1602

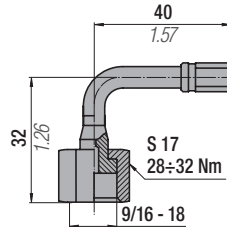

code 36P9/1603

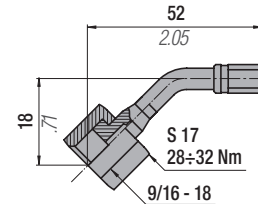

ORFS CONNECTIONS

Raccordi tubo-cilindro/pannello - Hose-cylinder/panel connections - Anschlüsse zwischen schlauch und Zylinder/Kontrollarmatur - Raccords tuyau-cylindre/tableau - Racores manguera-cilindros/panel - Racord tubo-cilindro/painel

code PA-S Port Adapter - Straight

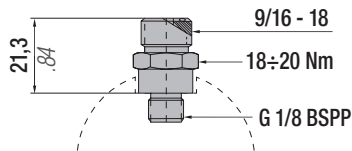

code PA-AS Port Adapter - Angle Swivel

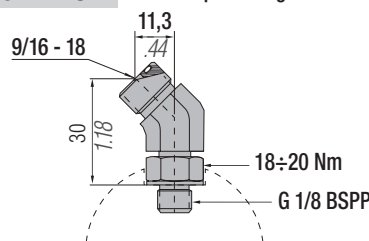

code PA-E Port Adapter - Elbow

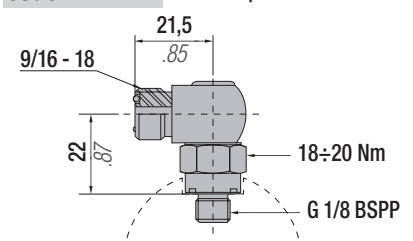

code PA-BTS Port Adapter - Brach Tee Swivel

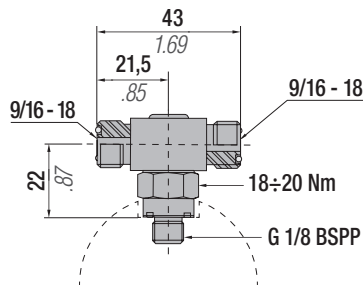

code PA-RT Port Adapter - Rum Tee

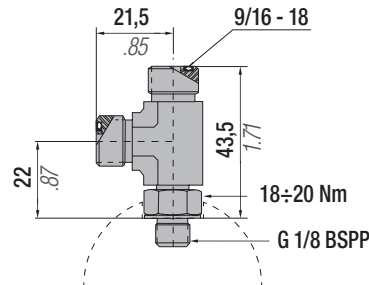

code PA-TWS Port Adapter - Two Way Swivel

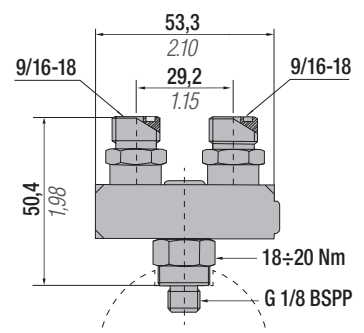

code PA-MWS Port Adapter - Multi Way Swivel

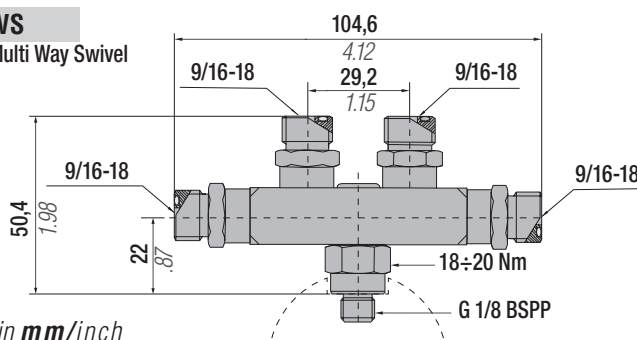

code PA-M6

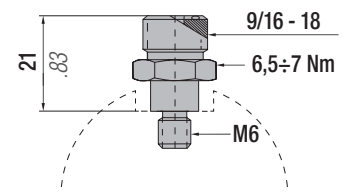

All dimensions in mm/inch



Raccordi di derivazione - Offtake connections - Anschlußstutzen - Raccords de dérivation - Racores de derivación - Racord de derivação

code SN-A

Swivel Nut-Angle

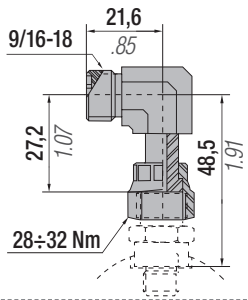

code SN-BT

Swivel Nut-Branch Tee

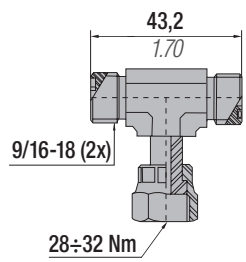

code SN-RT

Swivel Nut-Run Tee

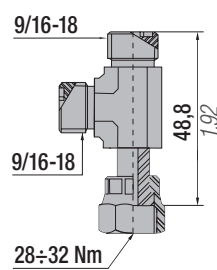

Raccordi tubo-tubo - Hose-hose connections - Anschlüsse zwischen Schlauch und Schlauch - Raccords tuyau-tuyau - Racores tubo-tubo - Racord tubo-tubo

code F-U

Fitting-Union

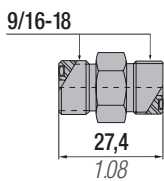

code F-E

Fitting-Elbow

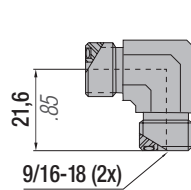

code F-T

Fitting-Tee

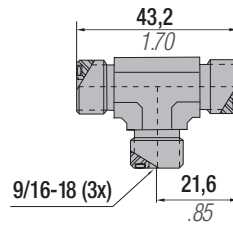

code F-C

Fitting-Cross

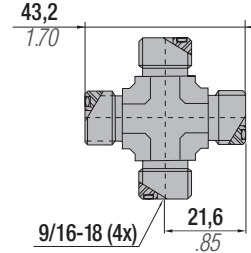



THIS PAGE IS INTENTIONALLY LEFT BLANK



CONTROL PANEL CP01A



IT
Micro pannello di controllo composto da base in alluminio, manometro, valvola per caricamento e scaricamento, tappo di rottura sovrappressione e protezione in acciaio. Idoneo per la gestione di impianti collegati realizzati con micro hose e micro connections. 16 uscite M6.

EN
Micro control panel with aluminium base, gauge, charging and discharging valve, overpressure rupture plug and steel protection. Suitable for hose systems equipped with micro hose and micro connections. 16 M6 ports.

DE
Micro-Kontrollarmatur mit Aluminiumsockel, Manometer, Auffüll- und Ablassventil, Überdruck-Bruchstecker und Stahlabdeckung. Geeignet für Verbundsysteme mit Micro-Kupplung und -Schläuchen. 16 M6 Anschlüsse.

FR
Mini panneau de contrôle avec base aluminium, équipé de manomètre, valve de chargement et déchargement, bouchon de rupture de surpression et protection acier ; il est adapté aux systèmes connectés équipés de mini tuyaux et mini connexions. 16 Portes M6.

ES
Micropanel de control con base en aluminio, manómetro, válvula de carga y descarga, tapón de rotura por sobrepresión y protección en acero. Idóneo para la gestión de instalaciones de cilindros conectados entre sí con micro mangueras y micro racores. 16 salidas M6.

PT
Micro Painel de Control com base em alumínio, manómetro, válvula de carga e descarga, plugue ruptura sobrepresão e protecção em aço. Adequado para sistemas de mangueiras, equipado com micro mangueiras e micro conexões. 16 saídas M6.

code	Pressure Gauge	Rupture Plug	Easy Manifold	Gauge Angle Position
39CP01A-...	bar/psi	✓	✓ p.256	0°* 180°

HOW TO ORDER

code
39CP01A-180

Gauge angle position

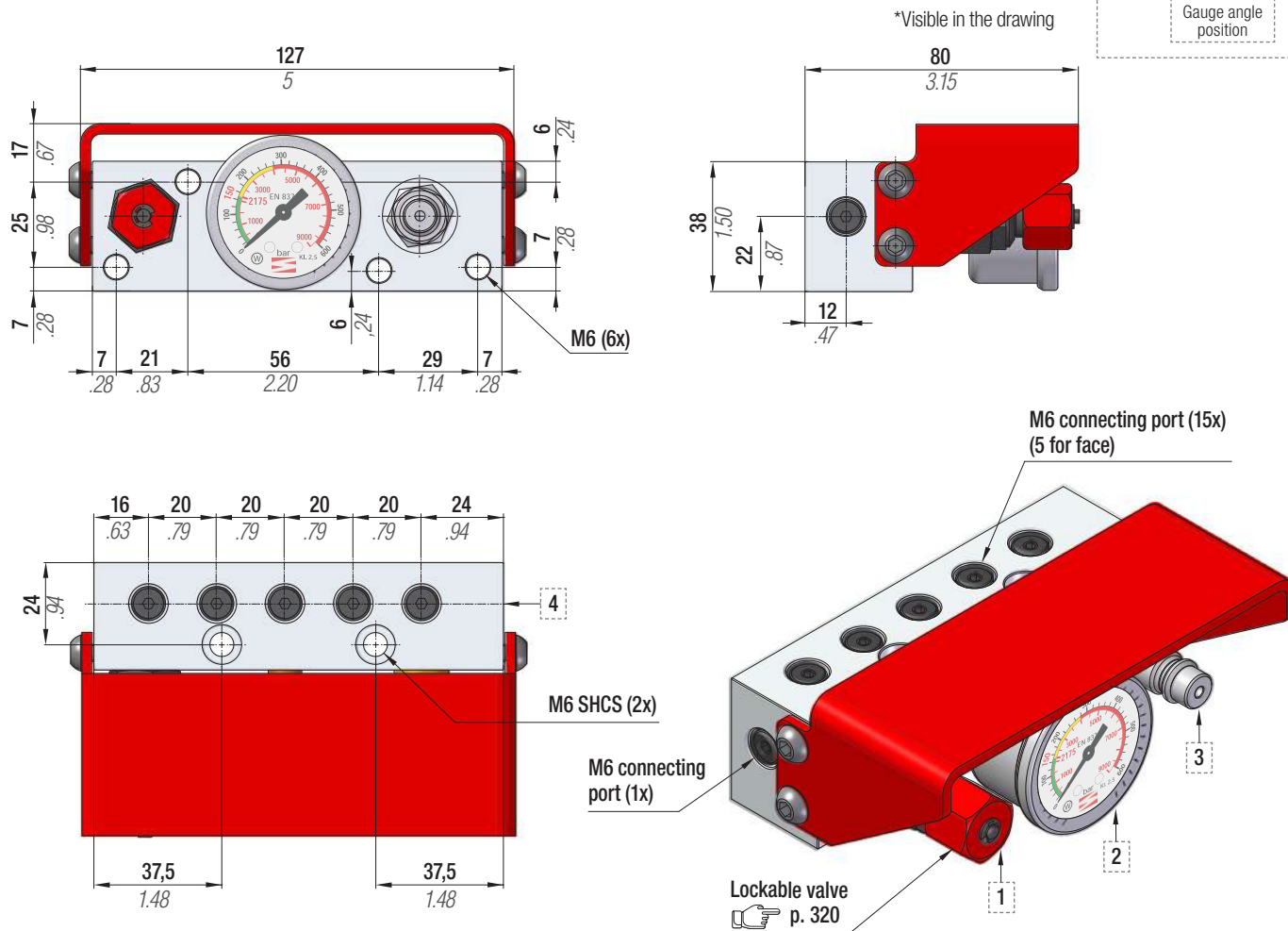

1	Valvola di scarico Discharging valve Auslaßventil Valve de déchargement Válvula de descarga Válvula de descarga	2	Manometro 0÷ 620 bar Pressure gauge 0÷620 bar Manometer 0÷ 620 bar Manomètre 0÷ 620 bar Manómetro 0÷ 620 bar Manómetro 0÷ 620 bar	3	Innesto rapido di caricamento Cejn Quick coupling for charging Cejn Steckkegel Cejn Accouplement rapide mâle Cejn Acoplamiento rápido para carga Cejn União rápida para carregamento Cejn	4	Tappo di rottura sovrappressione Over pressure rupture plug Überdruck-Bruchstecker Bouchon de rupture de surpression Tapón de rotura por sobrepresión Plugue ruptura sobrepresão
---	--------------------------------------------------------------------------------------------------------------------------------	---	--------------------------------------------------------------------------------------------------------------------------------------------------	---	----------------------------------------------------------------------------------------------------------------------------------------------------------------------------------------------------------	---	-------------------------------------------------------------------------------------------------------------------------------------------------------------------------------------------------

IT

Pannello standard per caricamento, regolazione, scaricamento e controllo della pressione nel sistema collegato. Consiste in una base provvista di manometro, valvola di caricamento e scaricamento, 3 uscite, protezione in acciaio. Può essere equipaggiato con disco di rottura (opzionale).

EN

Standard control panel to charge, adjust and check the pressure in the connected system. It consists of a plate with pressure gauge, charging and discharging valve, 3 outlets, steel case and can be equipped with a rupture disc (optional).

DE

Standard-Schaltarmatur zur Ladung, Regulierung, Entladung und Kontrolle des Drucks im angeschlossenen System. Bestehend aus einer Sockel mit Manometer, Lade- und Entladeventil, 3 Ausgängen sowie Schutzabdeckung aus Stahl. Kann mit einer Berstscheibe ergänzt werden (Zubehör).

FR

Panneau standard pour le chargement, le réglage, le déchargement et le contrôle de la pression dans le système relié. Il est formé par une embase équipée de manomètre, vanne de chargement et déchargement, 3 sorties, protection en acier. Il peut être équipé d'un disque de rupture (option).

ES

Panel estándar para la carga, regulación, descarga y control de la presión en sistemas de cilindros conectados. Consiste en una base provista de manómetro, válvula de carga y descarga, 3 salidas, protección en acero. Puede equiparse con disco de rotura (opcional).

PT

Painel standard para carga, regulação, descarga e controlo da pressão no sistema ligado. É composto por uma base com manómetro. Válvula de carga e de descarga, 3 saídas, protecção em aço. Pode ser equipado com disco de rotura (opcional).

code	Pressure Gauge	Rupture Plug	Easy Manifold p.256	Gauge Angle Position	
				0°*	180°
39CPVC-...	bar/psi	✗	✓	-	180
39CPVC-... + 39DR004	bar/psi	✓	✓	-	180
39CPVC-... + 39TS460	bar/psi	✓	✓	-	180

*Visible in the drawing

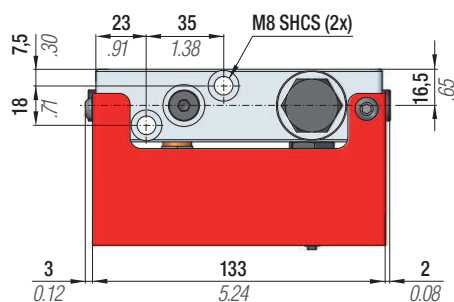
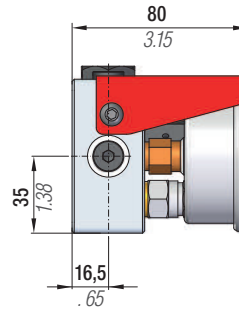
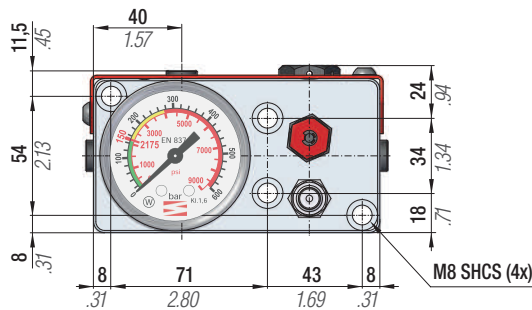

HOW TO ORDER

code

39CPVC-180

Gauge angle position

code 39TS460 4.2 - option

code 39DR004 4.1 - option

standard 4

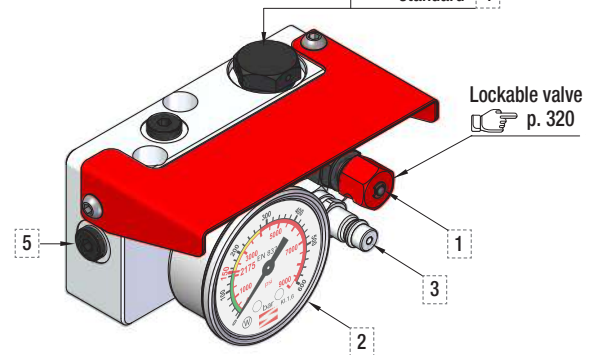

1	Valvola di scarico Discharging valve Auslaßventil Valve de déchargement Válvula de descarga Válvula de descarga	2	Manometro 0÷ 620 bar Pressure gauge 0÷620 bar Manometer 0÷ 620 bar Manomètre 0÷ 620 bar Manómetro 0÷ 620 bar	3	Innesto rapido di caricamento Cejn Quick coupling for charging Cejn Steckkegel Cejn Accouplement rapide mâle Cejn Acoplamiento rápido para carga Cejn União rápida para carregamento Cejn	4	Tappo di chiusura M20 Closing plug M20 Verschlussstopfen M20 Bouchon de fermeture M20 Tapón de cierre M20 Plugue de fechamento M20	code: 39TS460
4.1	Tappo di rottura sovrappressione Over pressure rupture plug Überdruck-Bruchstecker Bouchon de rupture de surpression Tapón de rotura por sobrepresión Plugue ruptura sobrepresão	4.2	Tappo di sicurezza sovrappressione CE Overpressure safety plug CE Überdruck Sicherheitsstecker CE Bouchon de sécurité surpression CE Tapón de rotura por sobrepresión CE Bujão de segurança sobrepresão	5	Fori di collegamento 1/8"G (4x) 1/8"G connecting ports (4x) Anschlussöffnung 1/8"G (4x) Trous de raccordement 1/8"G (4x) Agujeros de conexión 1/8"G (4x) Furo de conexão 1/8"G (4x)			

CONTROL PANEL MCPC / CP19A

Replace code 39MCPB



IT

Il mini pannello di controllo Special Springs, grazie a un design miniaturizzato e unico, offre una grande flessibilità d'uso che aumenta con le unità addizionali AUMCP. Consiste in un blocchetto di alluminio provvisto di manometro, valvola di caricamento e scaricamento, 4 uscite, valvola d'intercettazione e tappo di rottura sovrappressione.

EN

The Special Springs mini control panel, thanks to its unique miniaturized design, offers wide flexibility of use, increased when combined with additional AUMCP units. It consists of a aluminium block with pressure gauge, charging and discharging valve, 4 outlets, on-off valve and overpressure rupture plug.

DE

Die Mini-Steuerung Special Springs bietet dank ihres miniaturisierten und einzigartigen Designs größte Benutzungsflexibilität, die mit den zusätzlichen AUMCP-Einheiten noch erhöht wird. Bestehend aus einem Aluminiumblock mit Manometer, Lade- und Entladeventil, 4 Ausgängen, Sperrventil und Überdruck-Bruchstecker.

FR

Grâce à une conception miniaturisée et unique, le mini-panneau de contrôle Special Springs offre une grande souplesse d'utilisation qui augmente avec les unités supplémentaires AUMCP. Il est formé par une plaque en aluminium équipée de manomètre, vanne de chargement et déchargement, 4 sorties, vanne d'arrêt et Bouchon de rupture surpression.

ES

El mini-panel de control Special Springs, gracias a su compacto y exclusivo diseño, ofrece una gran flexibilidad de uso, más si cabe al poder añadir unidades adicionales AUMCP. Consiste en un bloque de aluminio provisto de manómetro, válvula de carga y descarga, 4 salidas, válvula de cierre y tapón de rotura por sobrepresión.

PT

O mini-painel de controlo Special Springs, graças a um design miniaturizado e exclusivo, oferece uma grande flexibilidade de utilização que aumenta com as unidades adicionais AUMCP. É composto por um bloco em alumínio com manómetro, válvula de carga e de descarga, 4 saídas, válvula de intercettazione e plugue de ruptura sobrepresão.

code	Pressure Gauge	Rupture Plug	Shut off valve	Easy Manifold p.256	Gauge Angle Position		
					0°*	180°	270°
39MCPB-...	bar/psi	✓	✓	✓	-	180°	270°
39CP19A-...	bar/psi	✓	✗	✓	-	180°	270°

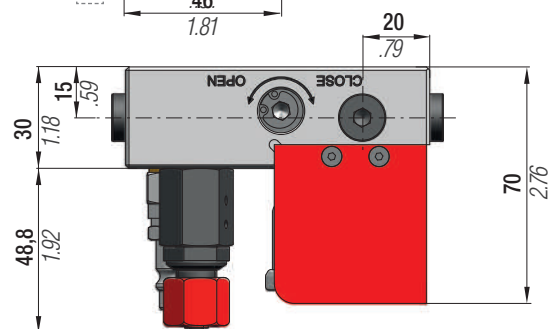
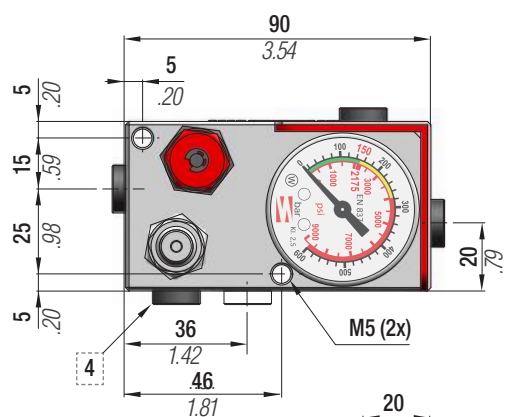

Lockable valve
p. 320

G 1/8" - Port (5x)

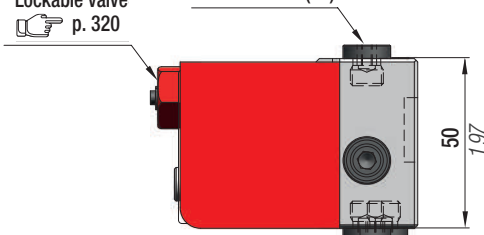

*Visible in the drawing

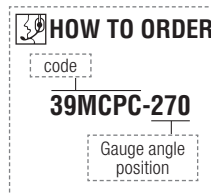

1	Valvola di scarico Discharging valve Auslaßventil Valve de déchargement Válvula de descarga Válvula de descarga	2	Manometro 0÷ 620 bar Pressure gauge 0÷620 bar Manometer 0÷ 620 bar Manomètre 0÷ 620 bar Manómetro 0÷ 620 bar Manómetro 0÷ 620 bar
---	--------------------------------------------------------------------------------------------------------------------------------	---	--------------------------------------------------------------------------------------------------------------------------------------------------

3	Innesto rapido di caricamento Cejn Quick coupling for charging Cejn Steckkegel Cejn Acoplamiento rápido para carga Cejn União rápida para carregamento Cejn	4	Tappo di rottura sovrappressione Over pressure rupture plug Überdruck-Bruchstecker Bouchon de rupture de surpression Tapón de rotura por sobrepresión Plugue ruptura sobrepresão
---	-------------------------------------------------------------------------------------------------------------------------------------------------------------------------	---	-------------------------------------------------------------------------------------------------------------------------------------------------------------------------------------------------

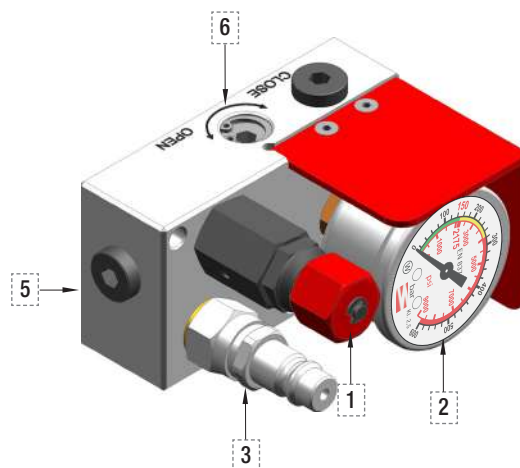

5	Fori di collegamento 1/8"G (5x) 1/8"G connecting ports (5x) Anschlussöffnung 1/8"G (5x) Trous de raccordement 1/8"G (5x) Agujeros de conexión 1/8"G (5x) Furo de conexão 1/8G (5x)	6	Valvola di intercettazione Shut off valve Sperrventil Valve d'arrêt Válvula de intercettazione Válvula de fecho
---	---------------------------------------------------------------------------------------------------------------------------------------------------------------------------------------------------	---	--------------------------------------------------------------------------------------------------------------------------------

CONTROL PANEL CP02A / CP08A / CP11A

(Ford, MABEC, Nissan, Renault and GM North America die Standard)



IT

Pannello di controllo secondo standard Ford e GM Nord America. Base in alluminio provvista di manometro, valvola di caricamento e scaricamento, adattatore 9/16-18 UNF ORFS, tappo di rottura sovrappressione e protezione in acciaio. 3 uscite G1/8" per gestione sistemi collegati.

EN

Control panel according to Ford and GM North America standards. Made up of aluminium base. Gauge, charging and discharging valve, 9/16-18 UNF ORFS adapter, over pressure rupture plug and steel protection. 3 ports G1/8".

DE

Kontrollarmatur gem. Ford und GM North America Normen. Mit Aluminiumgehäuse, Manometer, Auffüll- und Ablassventil, 9/16-18 UNF ORFS Adapter, Überdruck-Bruchstecker und Stahlabdeckung. 3 G1/8" Anschlüsse.

FR

Panneau de contrôle selon les standards Ford et GM, Amérique du Nord, base en aluminium. Manomètre, valve de chargement et déchargement, adaptateur 9/16-18 UNF ORFS, Bouchon de rupture de surpression et protection acier, 3 ports G1/8".

ES

Panel de control según standard Ford y GM Norte América. Base de aluminio con manómetro, válvula de carga y descarga, adaptador 9/16-18 UNF ORFS, tapón de rotura por sobrepresión y protección en acero. 3 salidas G1/8" para gestión sistemas de cilindros conectados.

PT

Painel de controlo de acordo com os Standards Ford e GM América do Norte. Fabricado a partir de uma base de alumínio, manómetro, válvula de carga e descarga, adaptador ORFS 9/16-18 UNF, Plugue ruptura sobrepresão e protecção em aço. 3 saídas G1/8" para sistemas de gestão relacionados.

code	Pressure Gauge	Rupture Plug	Easy Manifold	Gauge Angle Position ↻	
				0°*	180°
39CP02A-...	bar/psi	✓	✗	-	180
39CP08A-...	bar/MPa	✓	✗	-	180
39CP11A-...	bar/psi	✗	✗	-	180

*Visible in the drawing

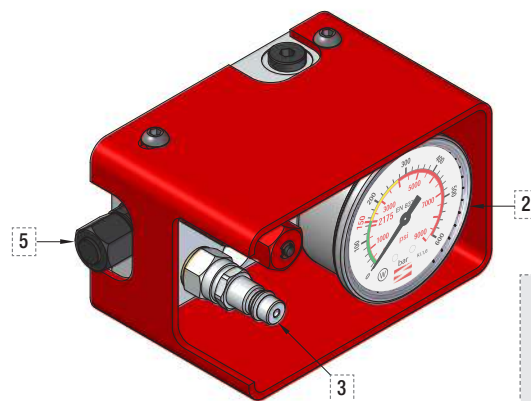
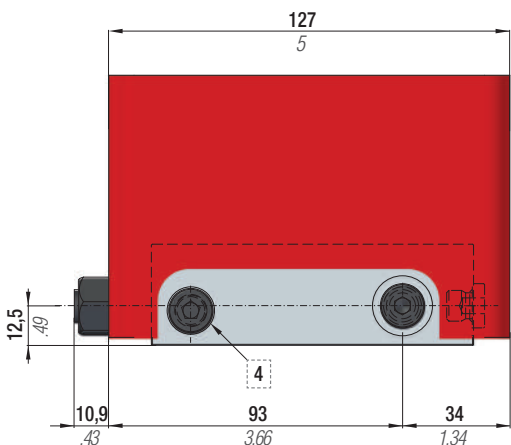
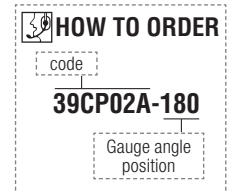
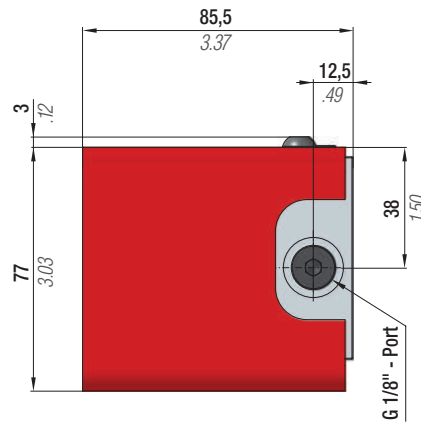
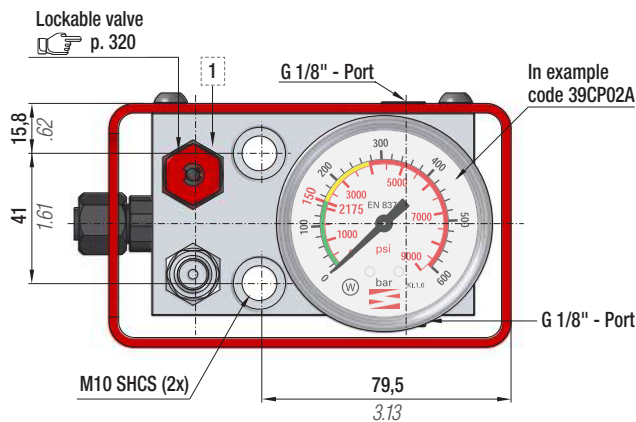

1 Valvola di scarico
Discharging valve
Auslaßventil
Valve de déchargement
Válvula de descarga
Válvula de descarga

2 Manometro 0 ÷ 620 bar Pressure gauge 0 ÷ 620 bar Manometer 0 ÷ 620 bar Manomètre 0 ÷ 620 bar Manómetro 0 ÷ 620 bar Manómetro 0 ÷ 620 bar	3 Innesto rapido di caricamento Cejn Quick coupling for charging Cejn Steckkegel Cejn Accouplement rapide mâle Cejn Acoplamiento rápido para carga Cejn União rápida para carregamento Cejn	4 Tappo di rottura sovrappressione Over pressure rupture plug Überdruck-Bruchstecker Bouchon de rupture de surpression Tapón de rotura por sobrepresión Plugue ruptura sobrepresão	5 Adattatore tenuta frontale 9/16-18 UNF O-Ring Face Seal Adapter 9/16-18 UNF O-ring-Dichtung Adapter 9/16-18 UNF Joint torique adaptateur 9/16-18 UNF O-ring face seal adapter 9/16-18 UNF Adaptador de vedação frontal 9/16-18 UNF
-----------------------------------------------------------------------------------------------------------------------------------------------------------	------------------------------------------------------------------------------------------------------------------------------------------------------------------------------------------------------------	---------------------------------------------------------------------------------------------------------------------------------------------------------------------------------------------------	-----------------------------------------------------------------------------------------------------------------------------------------------------------------------------------------------------------------------------------------------------

IT
Pannello di controllo con base in alluminio, provvisto di manometro con valvola di intercettazione, valvola di caricamento e scaricamento, tappo di rottura sovrappressione, protezione in acciaio, 9 uscite da G1/4" per gestione sistemi collegati. La valvola di intercettazione protegge il manometro dalla pressione pulsante durante il funzionamento. Per controllare e regolare la pressione dell'impianto bisogna aprire la valvola di intercettazione del manometro.

EN
Control panel with aluminium base, gauge with shut-off valve, charging and discharging valve, over pressure rupture plug, steel protection. 9 G1/4" ports for hose systems managing. With shut-off valve closed the gauge is protected from pulsating pressure during operation. For checking and adjusting the pressure the interception valve on the gauge must be opened.

DE
Kontrollarmatur mit Aluminiumgehäuse, Manometer mit Sperrventil, Auffüll- und Ablassventil, Überdruck-Bruchstecker und Stahlabdeckung. 9 G1/4" Anschlüsse zur Steuerung der Verbundsysteme. Das Schließen des Manometers mit dem Sperrventil schützt vor Druckschwankungen während des Arbeitsgangs. Zum Prüfen und Einstellen des Drucks muss das Sperrventil am Manometer geöffnet sein.

FR
Panneau de contrôle avec embase aluminium, équipé de manomètre à valve d'arrêt, valve de chargement et déchargement, bouchon de rupture de surpression et protection acier. Ports 9 G1/4" pour gestion de la connectique. Lorsque la valve d'arrêt est fermée, le manomètre est protégé des vibrations dues à la pression durant les opérations. Pour contrôler et ajuster la pression, il convient d'ouvrir la valve d'interception au niveau du manomètre.

ES
Panel de control con base de aluminio, manómetro con válvula de cierre, válvula de carga y descarga, tapón de rotura por sobrepresión y protección en acero. 9 salidas G1/4" para gestión de sistemas interconectados. Con válvula de cierre cerrada el manómetro está protegido de picos de presión durante un funcionamiento normal. Para controlar y regular la presión abrir la válvula de cierre del manómetro.

PT
Painel de Controlo com base em alumínio, manómetro com válvula de obturação, plugue ruptura sobrepresão e protecção em aço. 9 furos* G1/4" para uso de sistemas de mangueiras. Com a válvula de obturação fechada fica protegido das pressões existentes durante a operação. Para verificar e ajustar a pressão, a válvula de intercepção no manómetro tem que estar aberta.

code	Pressure Gauge	Rupture Plug	Easy Manifold	Gauge Angle Position	
				0°*	180°
39CP03A-...	bar/psi	✓	✗	-	180

HOW TO ORDER

code
39CP03A-180

Gauge angle position

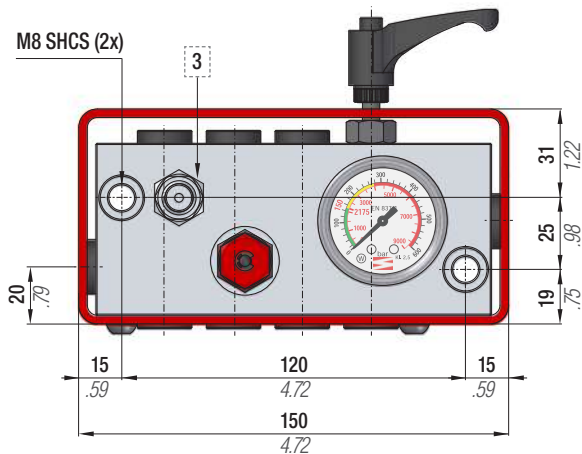

*Visible in the drawing

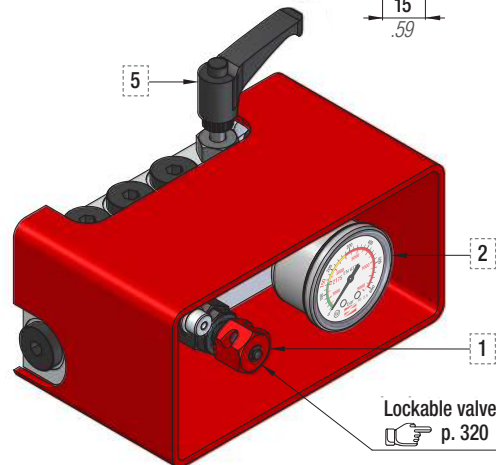
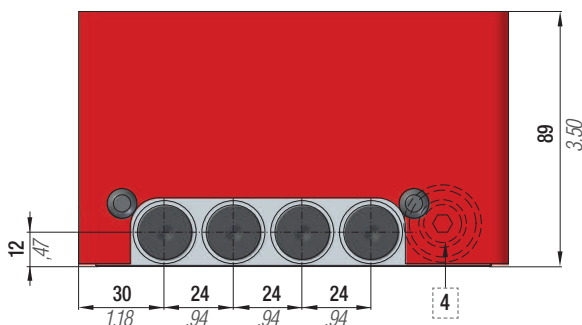
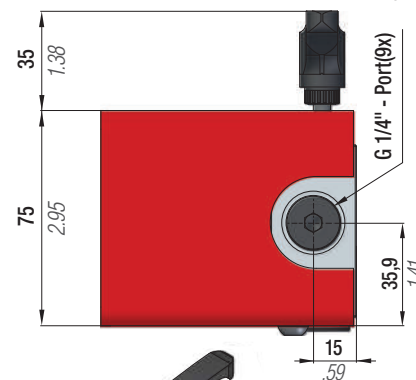

Lockable valve
p. 320

1	Valvola di scarico Discharging valve Auslassventil Valve de déchargement Válvula de descarga Válvula de descarga	2	Manometro 0÷ 620 bar Pressure gauge 0÷ 620 bar Manometer 0÷ 620 bar Manomètre 0÷ 620 bar Manómetro 0÷ 620 bar Manómetro 0÷ 620 bar	3	Innesto rapido di caricamento Cejn Quick coupling for charging Cejn Steckkegel Cejn Accouplement rapide mâle Cejn Acoplamiento rápido para carga Cejn União rápida para carregamento Cejn	4	Tappo di rottura sovrappressione Over pressure rupture plug Überdruck-Bruchstecker Bouchon de rupture de surpression Tapón de rotura por sobrepresión Plugue ruptura sobrepresão	5	Valvola di intercettazione Shut off valve Sperrventil Valve d'arrêt Válvula de intercepción Válvula de fecho
---	---------------------------------------------------------------------------------------------------------------------------------	---	---------------------------------------------------------------------------------------------------------------------------------------------------	---	----------------------------------------------------------------------------------------------------------------------------------------------------------------------------------------------------------	---	-------------------------------------------------------------------------------------------------------------------------------------------------------------------------------------------------	---	-----------------------------------------------------------------------------------------------------------------------------



IT
Pannello di controllo con base in alluminio provvisto di sensore di pressione con display digitale, valvola di caricamento e scaricamento, tappo di rottura sovrappressione, protezione in acciaio, 2 uscite da 1/8" gas per gestione sistemi collegati. Collegando direttamente il sensore di pressione al controllo pressa è possibile impostare un range di lavoro desiderato al di fuori del quale il dispositivo invierà un segnale di allarme.

EN
Control panel with aluminium base, equipped with pressure sensor with digital display, charging and discharging valve, over pressure rupture plug, steel protection and two 1/8" gas outlets for hose system managing. By connecting directly the pressure sensor with the Press control unit, it is possible to set a desired working range, outside this value, the control unit will send an alarm signal.

DE
Kontrollarmatur mit Aluminiumgehäuse, ausgestattet mit Drucksensor mit Digital-Display, Auffüll- und Ablassventil, Überdruck-Bruchstecker, Stahlabdeckung und zwei 1/8" Anschlüssen zur Steuerung der Verbundsysteme. Bei der direkten Verbindung des Drucksensors mit der Pressensteuerung kann der gewünschte Arbeitsbereich eingestellt werden, außerhalb dieses Werts sendet die Einheit ein Alarmsignal.

FR
Panneau de contrôle avec embase en aluminium, équipé de senseur de pression à écran numérique, chargement et déchargement valve, Bouchon de rupture de surpression, protection en acier et deux sorties 1/8 gaz pour la gestion des systèmes connectés. En reliant directement le senseur de pression au système de gestion de la presse on peut établir un éventail désiré des valeurs de travail, au dehors de ces valeurs, le dispositif émettra un signal d'alarme.

ES
Panel de control con base de aluminio, provisto de sensor de presión con pantalla digital, válvula de carga y descarga, tapón de rotura por sobrepresión, protección en acero, 2 salidas de 1/8" gas para gestión de sistemas conectados. Conectando directamente el sensor de presión al control de la prensa es posible determinar unos rangos de trabajo, fuera de los cuales el dispositivo envía una señal de alarma.

PT
Painel de controlo com base de alumínio, equipado com sensor de pressão digital, válvula de carga e descarga, Plugue ruptura sobrepresão, sistema de protecção de aço e duas tomadas de 1/8" gas para ligação a mangueiras. ao ligar directamente o sensor de pressão com a unidade de controlo, é possível definir o funcionamento desejado, fora destes valores, a unidade de controlo envia um sinal de alarme.

code	Pressure Gauge	Rupture Plug	Easy Manifold	59CD01A	59CR01A
39CP06B	bar/psi/Mpa	✓	✗	✓	✗
39CP09B	bar/psi/Mpa	✓	✗	✗	✓

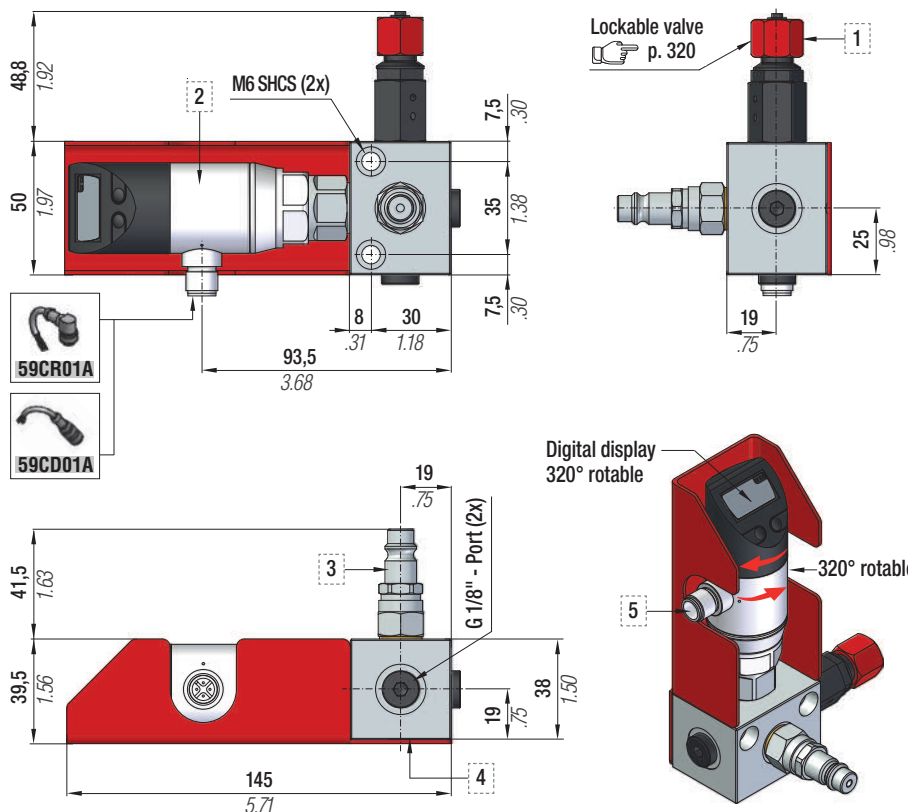

Technical data	
Electrical connector type	M12x1 - Male (4-pin), A-coded
Pressure connection	G 1/4" DIN 3852
Nominal pressure	0 - 600 bar
Burst pressure	1570 bar
Operating voltage U _o	18...36 V DC
Output current max.	150 mA
Current draw max	50 mA
Switching frequency f	170 Hz
Temperature range	- 25°C... + 85°C
Degree of protection as per IEC 60529	IP67 when connected

Always depressurize and disconnect sensors from the power supply before establishing an electrical connection.



Electrical connections	Pin number	Wire color	Factory setting
Supply +	1	Brown	-
Supply -	3	Blue	-
Out 1	4	Black	PNP Switching output / IO-Link
Out 2	2	White	PNP Switching output

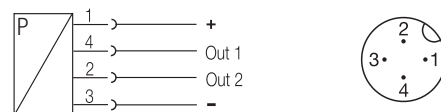

Electrical connections	Programmable settings
Out 1	PNP-NPN Switching output / IO-Link
Out 2	PNP-NPN Switching output / 4...20mA - 0-10V analog output

1 Valvola di scarico Discharging valve Auslassventil Valve de déchargement Válvula de descarga Válvula de descarga	2 Manometro 0÷ 600 bar Pressure gauge 0÷ 600 bar Manometer 0÷ 600 bar Manomètre 0÷ 600 bar Manómetro 0÷ 600 bar Manómetro 0÷ 600 bar	3 Innesto rapido di caricamento Cejn Quick coupling for charging Cejn Steckkegel Cejn Accouplement rapide mâle Cejn Acoplamiento rápido para carga Cejn União rápida para carregamento Cejn	4 Tappo di rottura sovrappressione Over pressure rupture plug Überdruck-Bruchstecker Bouchon de rupture de surpression Tapón de rotura por sobrepresión Plugue ruptura sobrepresão	5 Connettore elettrico Electrical Elektrische Connecteur électrique Eléctrica Conector Conector elétrico
--------------------------------------------------------------------------------------------------------------------------------------	--------------------------------------------------------------------------------------------------------------------------------------------------------	---------------------------------------------------------------------------------------------------------------------------------------------------------------------------------------------------------------	------------------------------------------------------------------------------------------------------------------------------------------------------------------------------------------------------	----------------------------------------------------------------------------------------------------------------------------

IT

Pannello di controllo con base in alluminio provvisto di sensore di pressione con display digitale, valvola di caricamento e scaricamento, tappo di rottura sovrappressione, protezione in acciaio, 2 uscite da 1/8" gas per gestione sistemi collegati. Collegando direttamente il sensore di pressione al controllo pressa è possibile monitorare in continuo il valore della pressione dell'impianto e gestirlo di conseguenza.

EN

Control panel with aluminium base, equipped with pressure sensor and digital display, charging and discharging valve, overpressure rupture plug, steel protective cover and two G 1/8" ports for managing linked systems. By connecting the pressure sensor to the press control, it is possible to constantly monitor the pressure value of the system and manage it accordingly.

DE

Kontrollarmatur mit Aluminiumgehäuse mit Drucksensor und Digitalanzeige, Befüll- und Ablassventil, Überdruck-Berstsicherung, Schutzabdeckung aus Stahl, zwei G1/8" Anschlussgewinden zur Steuerung von Verbundsystemen. Durch den Anschluss des Drucksensors direkt an die Pressensteuerung ist es möglich, den Druck der Anlage kontinuierlich zu überwachen und entsprechend zu steuern.

FR

Panneau de contrôle avec base en aluminium, équipé d'un capteur de pression et d'un affichage numérique, valve de chargement/déchargement, bouchon de rupture pour surpression, couverture de protection en acier et deux ports G 1/8" pour la gestion des systèmes connectés. En connectant le capteur de pression à la commande de la presse, il est possible de surveiller en permanence la valeur de pression du système et de la gérer en conséquence.

ES

Panel de control con base de aluminio equipado con sensor de presión con pantalla digital, válvula de carga y descarga, tapón de rotura por sobrepresión, protección de acero, 2 salidas G1/8" para administrar los sistemas conectados. Conectando directamente el sensor de presión al control de la prensa, es posible monitorear continuamente el valor de presión del sistema y administrarlo en consecuencia.

PT

Painel de controle com base em alumínio, fornecido com sensor de pressão e display digital, válvula de carregamento e descarregamento, bujão de ruptura para sobre pressão, 2 saídas G1/8" para verificação do sistema. Conectando o painel ao comando da prensa, é possível monitorar continuamente a pressão de trabalho do sistema, monitorando com total segurança o funcionamento.

code	Pressure Gauge	Rupture Plug	Easy Manifold	59CD01A	59CR01A
39CP20B	bar/psi/Mpa	✓	✗	✓	✗
39CP21B	bar/psi/Mpa	✓	✗	✗	✓

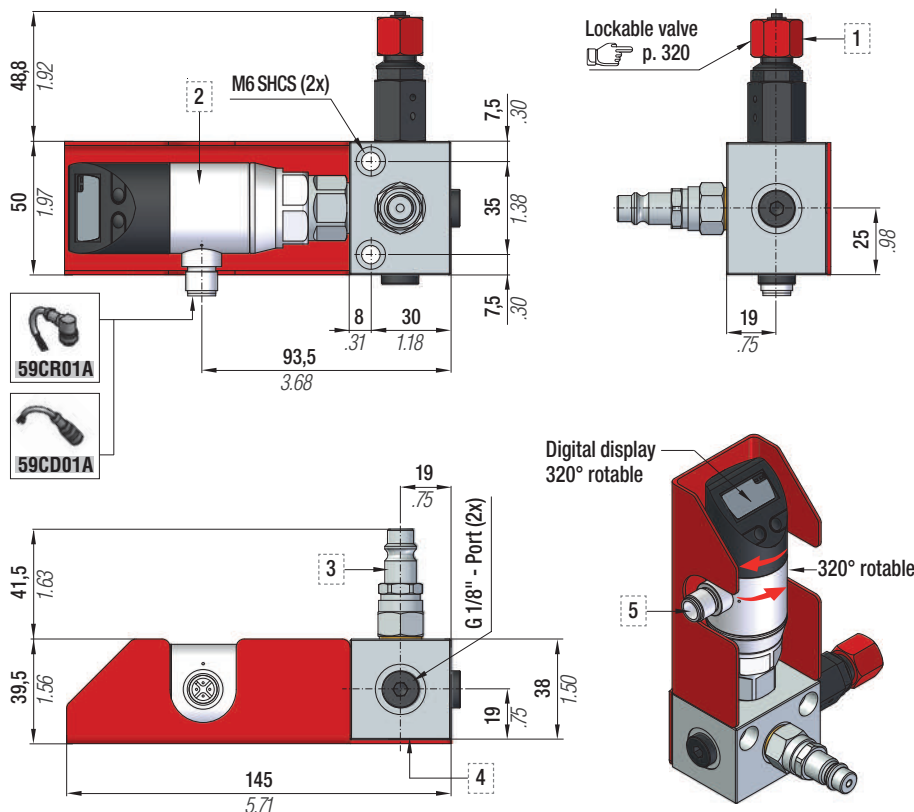

Technical data	
Electrical connector type	M12x1 - Male (4-pin), A-coded
Pressure connection	G 1/4" DIN 3852
Nominal pressure	0 - 600 bar
Burst pressure	1570 bar
Operating voltage U _o	18...36 V DC
Output current max.	150 mA
Current draw max	50 mA
Switching frequency f	170 Hz
Temperature range	-25°C... +85°C
Degree of protection as per IEC 60529	IP67 when connected

Always depressurize and disconnect sensors from the power supply before establishing an electrical connection.

Electrical connections	Pin number	Wire color	Factory setting
Supply +	1	Brown	-
Supply -	3	Blue	-
Out 1	4	Black	PNP Switching output / IO-link
Out 2	2	White	4...20mA analog output

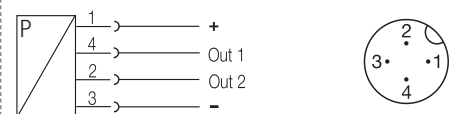

Electrical connections	Programmable settings
Out 1	PNP-NPN Switching output / IO-Link
Out 2	PNP-NPN Switching output / 4...20mA - 0-10V analog output

1	Valvola di scarico Discharging valve Auslassventil Valve de déchargement Válvula de descarga Válvula de descarga	2	Manometro 0÷ 600 bar Pressure gauge 0÷ 600 bar Manometer 0÷ 600 bar Manômetro 0÷ 600 bar Manómetro 0÷ 600 bar	3	Innesto rapido di caricamento Cejn Quick coupling for charging Cejn Steckkegel Cejn Accouplement rapide mâle Cejn Acoplamiento rápido para carga Cejn União rápida para carregamento Cejn	4	Tappo di rottura sovrappressione Over pressure rupture plug Überdruck-Bruchstecker Bouchon de rupture de surpression Tapón de rotura por sobrepresión Plugue ruptura sobrepresão	5	Connettore elettrico Electrical connector Elektrische Connecteur électrique Conector eléctrico Conector elétrico
---	---------------------------------------------------------------------------------------------------------------------------------	---	---------------------------------------------------------------------------------------------------------------------------	---	----------------------------------------------------------------------------------------------------------------------------------------------------------------------------------------------------------	---	-------------------------------------------------------------------------------------------------------------------------------------------------------------------------------------------------	---	---------------------------------------------------------------------------------------------------------------------------------



CONTROL PANEL CP07A / CP10A / CP12A



IT
Pannello di controllo con base in alluminio provvisto di manometro, valvola di caricamento e scaricamento, tappo di rottura sovrappressione, protezione in acciaio, 3 uscite da 1/4" gas e un uscita da 1/8" gas per gestione sistemi collegati.



EN
Control panel with aluminium base, equipped with gauge, charging and discharging valve, over pressure rupture plug, steel protection and three 1/4" and one 1/8" gas outlets for hose system managing.

DE
Kontrollarmatur mit Aluminiumgehäuse, Manometer, Auffüll- und Ablassventil, Überdruck-Bruchstecker, Stahlabdeckung, drei 1/4" und eine 1/8" Gas-Anschlüsse zur Steuerung der Verbundsysteme.

FR
Panneau de contrôle avec base en aluminium pourvu de manomètre, valve de chargement-déchargement, bouchon de rupture de surpression, protection en acier et trois sorties 1/4 gaz et une sortie 1/8 gaz pour la gestion des systèmes connectés.

ES
Panel de control con base de aluminio provisto de manómetro, válvula de carga y descarga, tapón de rotura por sobrepresión, protección en acero, 3 salidas de 1/4" gas y 1 salida de 1/8" gas para gestión de sistemas conectados.

PT
Painel de controlo com base de alumínio, equipado com manómetro, válvula de carga e descarga, plugue ruptura sobrepresão, sistema de protecção de aço, três tomadas de 1/4" e uma 1/8" gas para ligação a mangueiras.

code	Pressure Gauge	Pressure Switch	Rupture Plug	Easy Manifold  p.256	Discharging valve position				Gauge Angle Position 		
					Pos. A	Pos. B	Pos. C	Pos. D	0°*	180°	270°
39CP07A._	bar/psi	✗	✓	✓	-	.1	.2	.3	-	180	270
39CP10A._	bar/psi	✓	✓	✓	-	.1	.2	✗	-	180	270
39CP12A._	bar/psi	✗	✗	✓	-	.1	.2	.3	-	180	270

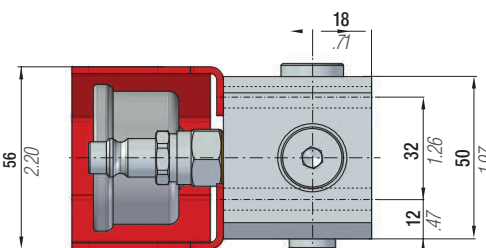
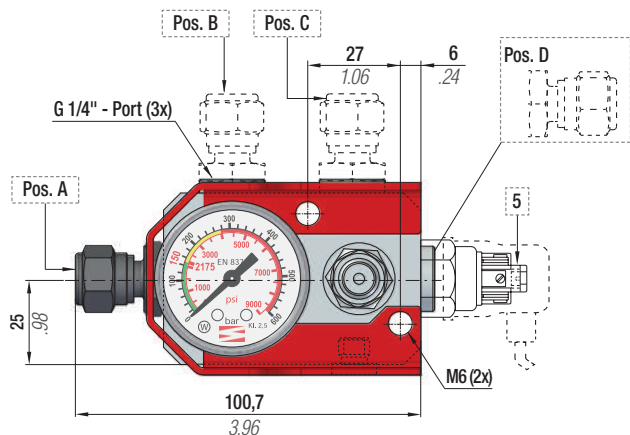

HOW TO ORDER

code Discharging valve position

39CP07A.1-180

Gauge angle position

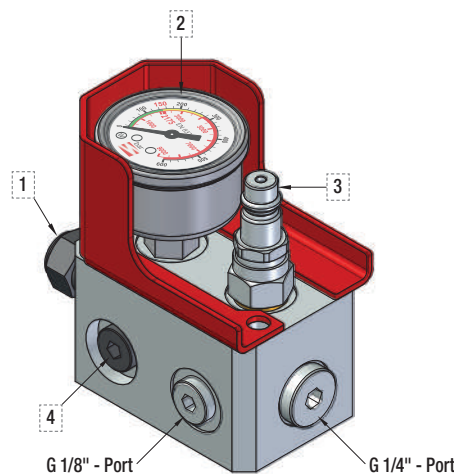
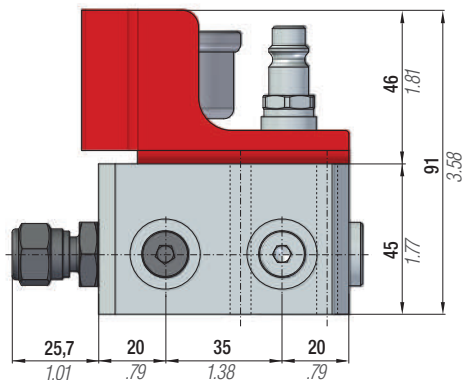

1 Valvola di scarico Discharging valve Auslaßventil Valve de déchargement Válvula de descarga Válvula de descarga	2 Manometro 0÷ 620 bar Pressure gauge 0÷ 620 bar Manometer 0÷ 620 bar Manomètre 0÷ 620 bar Manómetro 0÷ 620 bar Manómetro 0÷ 620 bar	3 Innesto rapido di caricamento Cejn Quick coupling for charging Cejn Steckkegel Cejn Accouplement rapide mâle Cejn Acoplamiento rápido para carga Cejn União rápida para carregamento Cejn	4 Tappo di rottura sovrappressione Over pressure rupture plug Überdruck-Bruchstecker Bouchon de rupture de surpression Tapón de rotura por sobrepresión Plugue ruptura sobrepresão	5 Pressostato 50÷300 bar Pressure switch 50÷300 bar Druckwächter 50÷300 bar Pressostat 50÷300 bar Pressostato 50÷300 bar Pressostato 50÷300 bar
--------------------------------------------------------------------------------------------------------------------------------------------	---------------------------------------------------------------------------------------------------------------------------------------------------------------	----------------------------------------------------------------------------------------------------------------------------------------------------------------------------------------------------------------------	-------------------------------------------------------------------------------------------------------------------------------------------------------------------------------------------------------------	--------------------------------------------------------------------------------------------------------------------------------------------------------------------------

IT

Pannello di controllo a standard Daimler. Base in alluminio provvisto di manometro, valvola di caricamento e scaricamento, pressostato e protezione in acciaio. 3 uscite 7/16-20UNF per gestione sistemi collegati. Può essere equipaggiato con tappo di rottura sovrappressione.

EN

Control panel according to Daimler standard. Made of aluminum base. Equipped with pressure gauge, charging and discharging valve, pressure switch and steel protection. Three 7/16-20UNF gas outlets for managing hose system. It can be equipped with over pressure rupture plug.

DE

Kontrollarmatur nach Daimler-Norm. Mit Aluminiumgehäuse, Manometer, Auffüll- und Ablassventil, Druckwächter und Stahlabdeckung. Drei 7/16-20UNF Gas-Anschlüsse zur Steuerung der Verbundsysteme. Einheit kann mit Überdruck-Bruchstecker ausgestattet werden.

FR

Panneau de contrôle selon le standard Daimler. Avec base en aluminium, manomètre, valve de chargement-déchargement, pressostat et protection en acier. Trois sorties 7/16-20UNF gaz pour la gestion des systèmes connectés. Il peut être équipé avec bouchon de rupture de surpression.

ES

Panel de control según standard Daimler. Con base de aluminio, manómetro, válvula de carga y descarga, presostato y protección en acero. 3 salidas de 7/16-20UNF gas para gestión de sistemas conectados. Puede equiparse con tapón de rotura por sobrepresión.

PT

Panel de controlo de acordo com o Standard Daimler. Fabricado a partir de uma base de alumínio. Equipado com manómetro, válvula de carga e descarga, pressostato e sistema de protecção de aço. Três saída de gás 7/16-20UNF para ligação a mangueiras. Pode ser equipado com plugue ruptura sobrepresão.

code	Pressure Gauge	Pressure Switch	Rupture Plug	Easy Manifold p.256	Gauge Angle Position	
					0°*	180°
39CP14A-...	bar/psi	✓	✗	✓	-	180
39CP14A-... + 39DR004	bar/psi	✓	✓	✓	-	180
39CP14A-... + 39TS460	bar/psi	✓	✓	✓	-	180

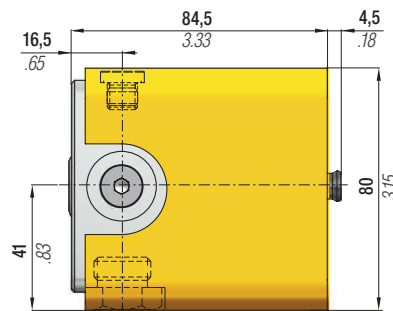
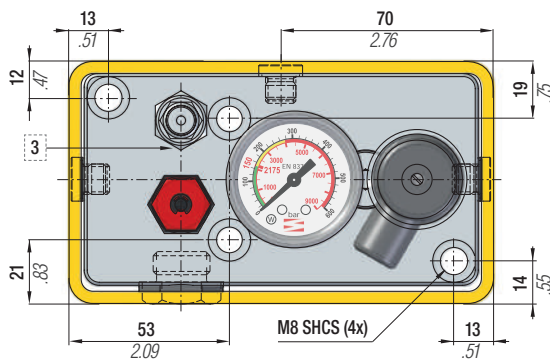

HOW TO ORDER

code

39CP14A-180

Gauge angle position

code 39TS460	5.2 - option
code 39DR004	5.1 - option
standard	5

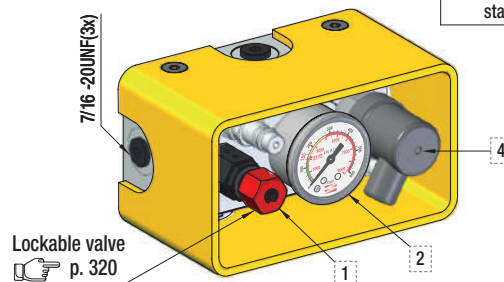
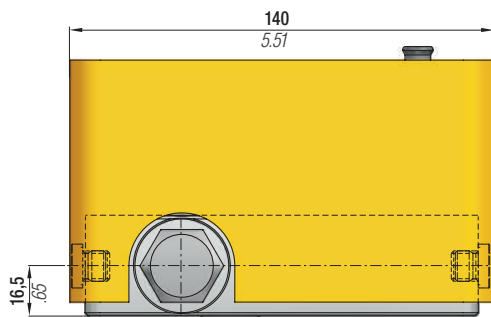

1	Valvola di scarico Discharging valve Auslaßventil Valve de déchargement Válvula de descarga Válvula de descarga	2	Manometro 0÷ 620 bar Pressure gauge 0÷ 620 bar Manomètre 0÷ 620 bar Manómetro 0÷ 620 bar	3	Innesto rapido di caricamento Cejn Quick coupling for charging Cejn Steckkegel Cejn Accouplement rapide mâle Cejn Acoplamiento rápido para carga Cejn União rápida para carregamento Cejn	4	Pressostato 50÷300 bar Pressure switch 50÷300 bar Druckwächter 50÷300 bar Pressostat 50÷300 bar Presostato 50÷300 bar Pressostato 50÷300 bar	code: 39TS460
5	Tappo di chiusura M20 Closing plug M20 Verschlussstopfen M20 Bouchon de fermeture M20 Tapon de cierre M20 Plugue de fechamento M20	5.1	Tappo di rottura sovrappressione Over pressure rupture plug Überdruck-Bruchstecker Bouchon de rupture de surpression Enchufe de ruptura de sobrepresión Plugue ruptura sobrepresão	5.2	Tappo di sicurezza sovrappressione CE Overpressure safety plug CE Überdruck Sicherheitsstecker CE Bouchon de sécurité surpression CE Enchufe de seguridad sobrepresión CE Bujão de segurança sobrepresão CE			

CONTROL PANEL CPVD (Fiat standard)



code	Pressure Gauge	Rupture Plug	Easy Manifold	Gauge Angle Position \odot	
				0°*	180°
39CPVD-...	bar/psi	✗	✗	-	180
39CPVD-... + 39DR004	bar/psi	✓	✗	-	180
39CPVD-... + 39TS460	bar/psi	✓	✗	-	180

*Visible in the drawing

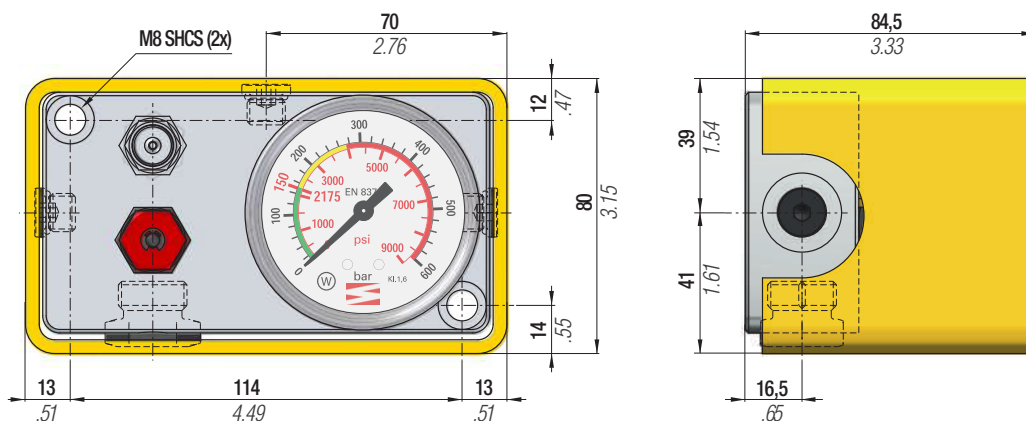

HOW TO ORDER

code

39CPVD-180

Gauge angle position

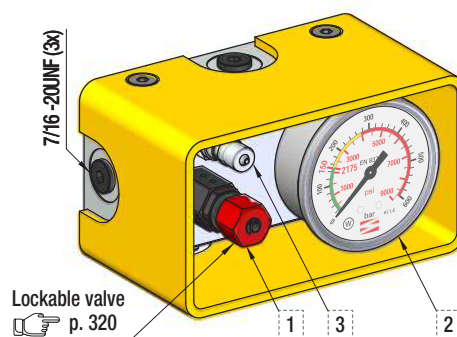
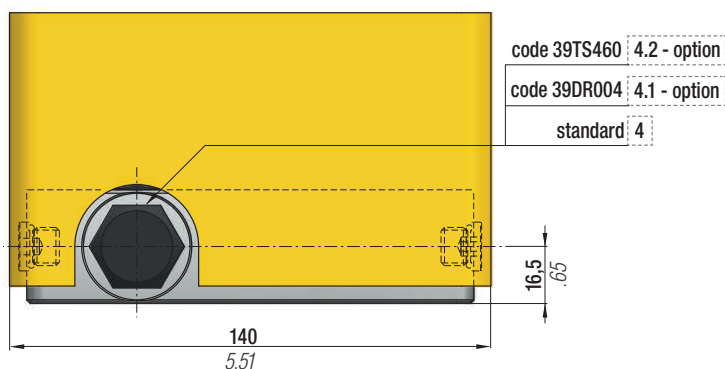

<p>1</p> <p>Valvola di scarico Discharging valve Auslaßventil Valve de déchargement Válvula de descarga Válvula de descarga</p>	<p>2</p> <p>Manometro 0÷ 620 bar Pressure gauge 0÷ 620 bar Manomètre 0÷ 620 bar Manómetro 0÷ 620 bar Manómetro 0÷ 620 bar</p>	<p>3</p> <p>Innesto rapido per caricamento ISO7241-1 Series B Quick coupling for charging ISO7241-1 Series B Steckkegel ISO7241-1 Series B Accouplement rapide mâle ISO7241-1 Series B Acoplamiento rápido para carga ISO7241-1 Series B União rápida para carregamento ISO7241-1 Series B</p>	<p>code: 39TS460</p>
<p>4</p> <p>Tappo di chiusura M20 Closing plug M20 Verschlussstopfen M20 Bouchon de fermeture M20 Tapon de cierre M20 Plugue de fechamento M20</p>	<p>4.1</p> <p>Tappo di rottura sovrappressione Over pressure rupture plug Überdruck-Bruchstecker Bouchon de rupture de surpression Enchufe de ruptura de sobrepresión Plugue ruptura sobrepresão</p>	<p>4.2</p> <p>Tappo di sicurezza sovrappressione CE Overpressure safety plug CE Überdruck Sicherheitsstecker CE Bouchon de sécurité surpression CE Enchufe de seguridad sobrepresion CE Bujão de segurança sobrepresão CE</p>	

CONTROL PANEL CPVD (FIAT standard) - Hose connections

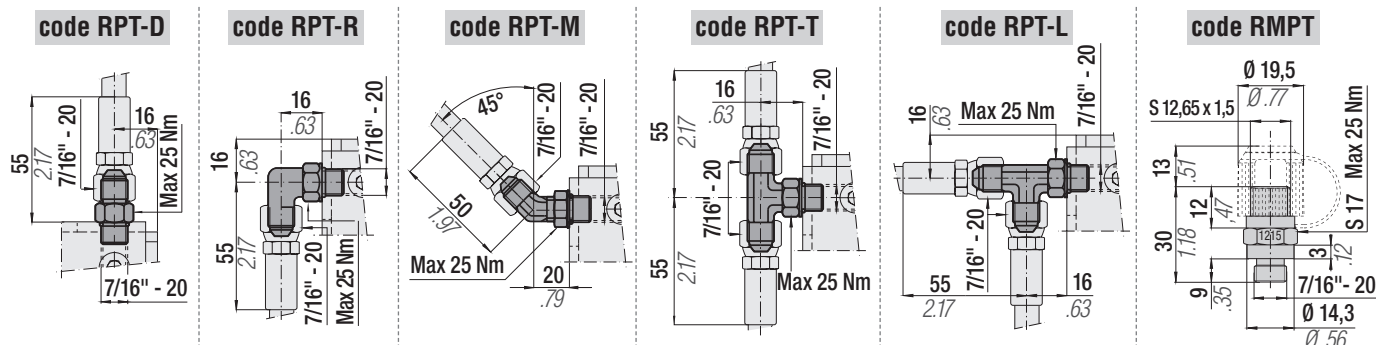

IT
Pannello di controllo con base in alluminio, provvisto di manometro, valvola di carica e protezione in acciaio. 2 uscite da 1/8" gas per gestione sistemi collegati.

EN
Control panel with aluminum base. Equipped with pressure gauge, charging valve and steel protection. Two 1/8" gas outlets for managing hose system.

DE
Kontrollarmatur mit Aluminiumgehäuse. Ausgestattet mit Manometer, Auffüllventil und Stahlabdeckung. Zwei 1/8" Gas-Anschlüsse zur Steuerung der Verbundsysteme.

FR
Panneau de contrôle avec base en aluminium. Equipé de manomètre, valve de chargement et protection en acier. Deux sorties 1/8" gaz pour la gestion des systèmes connectés.

ES
Panel de control con base de aluminio. Equipado con manómetro, válvula de carga y protección en acero. 2 salidas de 1/8" gas para gestión de sistemas conectados.

PT
Painel de controlo com base de alumínio. Equipado com manómetro, válvula de carga e sistema de protecção de aço. Duas saídas de gás 1/8" para ligação a mangueiras.

code	Pressure Gauge	Rupture Plug	Easy Manifold	Gauge Angle Position	
				0°*	180°
39CP15A-...	bar/MPa	X	X	-	180

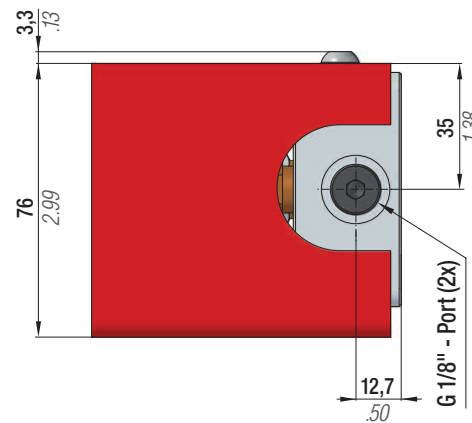
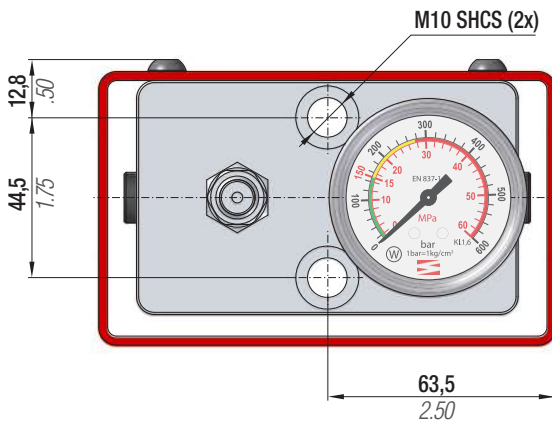

*Visible in the drawing

HOW TO ORDER

code
39CP15A-180
Gauge angle position

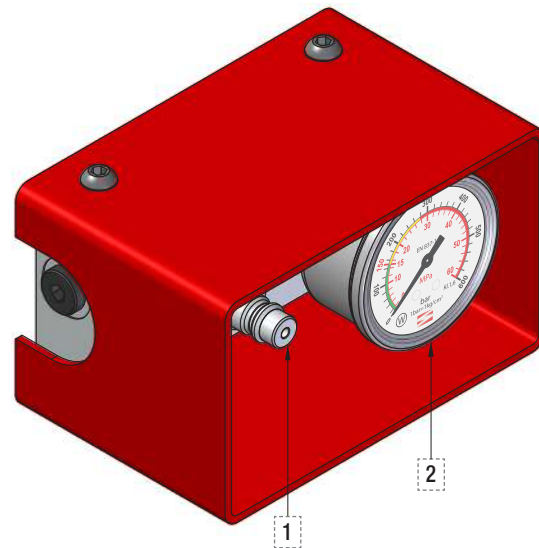
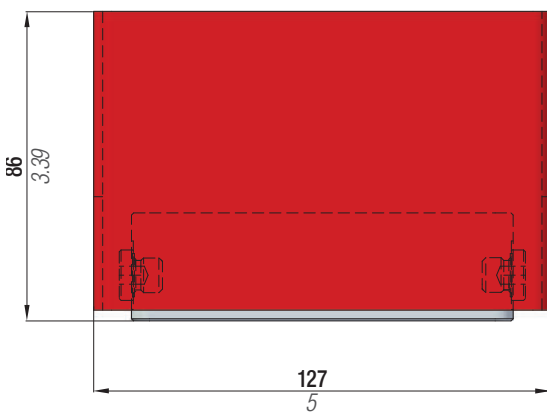

- | | |
|--------------------------------------------------------------------------------------------------------------------------------------------------------------------------------------------------------------------------------------|-------------------------------------------------------------------------------------------------------------------------------------------------------------------------------|
| <p>1</p> <p>Innesto rapido di caricamento Cejn
Quick coupling for charging Cejn
Steckkegel Cejn
Accouplement rapide mâle Cejn
Acoplamiento rápido para carga Cejn
União rápida para carregamento Cejn</p> | <p>2</p> <p>Manometro 0÷ 600 bar
Pressure gauge 0÷ 600 bar
Manometer 0÷ 600 bar
Manomètre 0÷ 600 bar
Manómetro 0÷ 600 bar
Manómetro 0÷ 620 bar</p> |
|--------------------------------------------------------------------------------------------------------------------------------------------------------------------------------------------------------------------------------------|-------------------------------------------------------------------------------------------------------------------------------------------------------------------------------|

code 39VS03B



Use only for 39CP15A

- IT** Dispositivo di scaricamento
EN Discharging device
DE Ablassvorrichtung
FR Dispositif de déchargement
ES Dispositivo de descarga
PT Dispositivo de descarga



CONTROL PANEL CP16A



IT

Pannello di controllo con base in alluminio, provvisto di manometro, valvola di caricamento e scaricamento, tappo di rottura sovrappressione, protezione in acciaio, 4 uscite da 1/8" gas per gestione sistemi collegati.

EN

Control panel with aluminum base. Equipped with pressure gauge, charging and discharging valve, over pressure rupture plug, steel protection, four 1/8" gas outlets for managing hose system.

DE

Kontrollarmatur mit Aluminiumgehäuse. Ausgestattet mit Manometer, Auffüll- und Ablassventil, Überdruck-Bruchstecker, Stahlabdeckung, vier 1/8" Gas-Anschlüsse zur Steuerung der Verbundsysteme.

FR

Panneau de contrôle avec base en aluminium. Equipé de manomètre, valve de chargement-déchargement, bouchon de rupture de surpression, protection en acier, quatre sorties 1/8" gaz pour la gestion des systèmes connectés.

ES

Panel de control con base de aluminio, provisto de manómetro, válvula de carga y descarga, tapón de ruptura por sobrepresión, protección en acero, 4 salidas de 1/8" gas para gestión de sistemas conectados.

PT

Painel de controlo com base de alumínio. Equipado com manómetro, válvula de carga e descarga, plugue ruptura sobrepresão, sistema de protecção de aço, quatro saídas de gás 1/8" para ligação a mangueiras.

code	Pressure Gauge	Rupture Plug	Easy Manifold	Gauge Angle Position \odot	
				0°*	180°
39CP16A-...	bar/psi	✓	✗	-	180

*Visible in the drawing

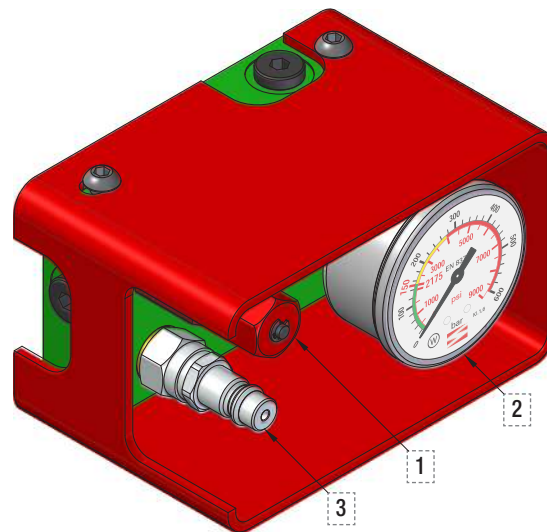
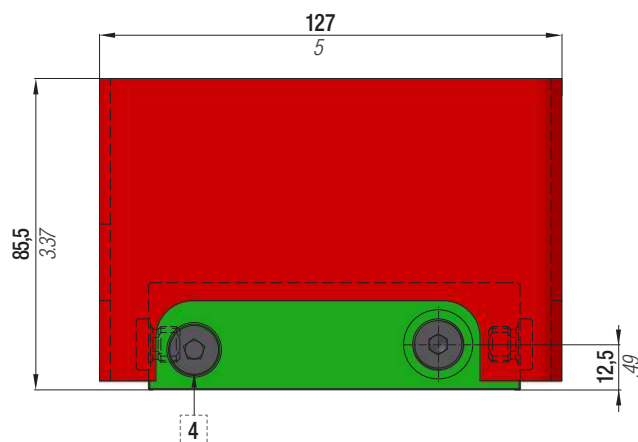
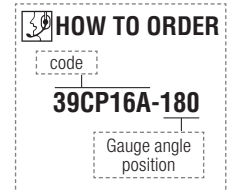
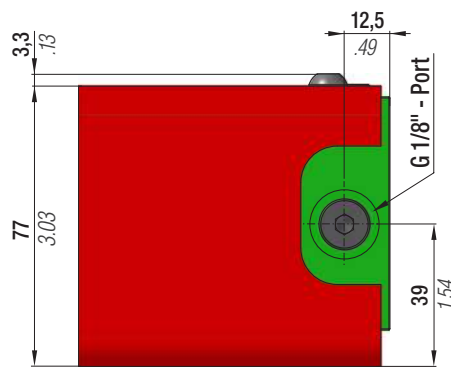
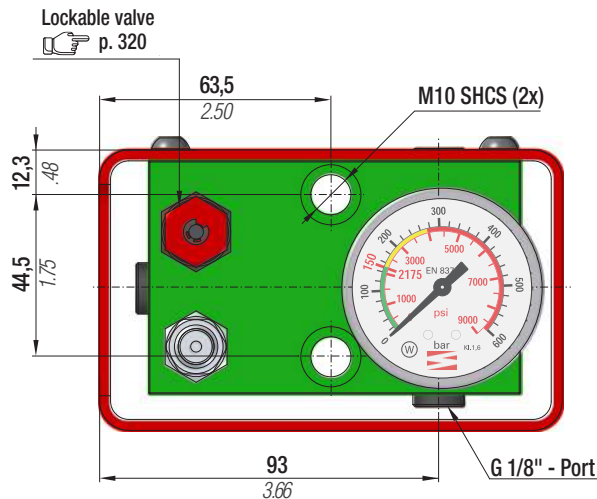

1	Valvola di scarico Discharging valve Auslaßventil Valve de déchargement Válvula de descarga Válvula de descarga	2	Manometro 0÷620 bar Pressure gauge 0÷620 bar Manometer 0÷620 bar Manomètre 0÷620 bar Manómetro 0÷620 bar Manómetro 0÷620 bar	3	Innesto rapido di caricamento Cejn Quick coupling for charging Cejn Steckkegel Cejn Accouplement rapide mâle Cejn Acoplamiento rápido para carga Cejn União rápida para carregamento Cejn	4	Tappo di rottura sovrappressione Over pressure rupture plug Überdruck-Bruchstecker Bouchon de rupture de surpression Tapón de ruptura por sobrepresión Plugue ruptura sobrepresão
---	--------------------------------------------------------------------------------------------------------------------------------	---	---------------------------------------------------------------------------------------------------------------------------------------------	---	----------------------------------------------------------------------------------------------------------------------------------------------------------------------------------------------------------	---	--------------------------------------------------------------------------------------------------------------------------------------------------------------------------------------------------

IT
Pannello di controllo con base in alluminio provvisto di sensore di pressione con display digitale, innesto rapido di caricamento Cejn, tappo di rottura sovrappressione, 3 uscite da 1/8" gas. Collegando il pannello al controllo pressa, è possibile impostare un range di lavoro desiderato al di fuori del quale il dispositivo invierà un segnale di allarme.

EN
Control panel with aluminium base, equipped with pressure sensor and digital display, Cejn-quick coupling for charging, overpressure rupture plug and three G 1/8" ports. By connecting the control panel to the press control, it is possible to set a desired working range outside which the unit sends an alarm signal.

DE
Kontrollarmatur mit Aluminiumgehäuse mit Drucksensor und Digitalanzeige, Cejn-Schnellkupplung zur Befüllung, Überdruck-Berstsicherung und drei G1/8" Anschlussgewinden. Durch den Anschluss der Kontrollarmatur an die Pressensteuerung ist es möglich, einen gewünschten Arbeitsbereich einzustellen, außerhalb dessen das Gerät ein Alarmsignal sendet.

FR
Panneau de contrôle avec base en aluminium, équipé d'un capteur de pression et d'un affichage numérique, raccord rapide Cejn pour le chargement, bouchon de rupture pour surpression et trois ports G 1/8". En connectant le panneau de contrôle au système de contrôle de la presse, il est possible de définir une plage de fonctionnement souhaitée en dehors de laquelle l'unité envoie un signal d'alarme.

ES
Panel de control con base de aluminio equipado con sensor de presión con pantalla digital, conexión de carga rápida Cejn, tapón de rotura por sobrepresión, 3 salidas 1/8" gas. Conectando el panel al control de la prensa es posible establecer un rango de trabajo deseado fuera del cual el dispositivo enviará una señal de alarma.

PT
Painel de controle com base em alumínio, fornecido com sensor de pressão e display digital, engate rápido de carregamento CEJN, bujão de ruptura para sobre pressão, 3 saídas G1/8". Conectando o painel ao comando da prensa, é possível determinar uma faixa de trabalho, que qualquer alteração desta faixa, o painel emitira um alarme.

code	Pressure Gauge	Rupture Plug	Easy Manifold	Pressure fitting position			
				Pos. A	Pos. B	Pos. C	Pos. A + C
39CP17A.	bar/MPa	✓	✗	.1	.2	.3	.4

(Toyota part number D-PACPS-B-...)

Straight	Cable length	Female	90°	Cable length	Female
59CD02A	2 meter		59CR02A	2 meter	
59CD03A	5 meter		59CR03A	5 meter	
59CD04A	10 meter		59CR04A	10 meter	

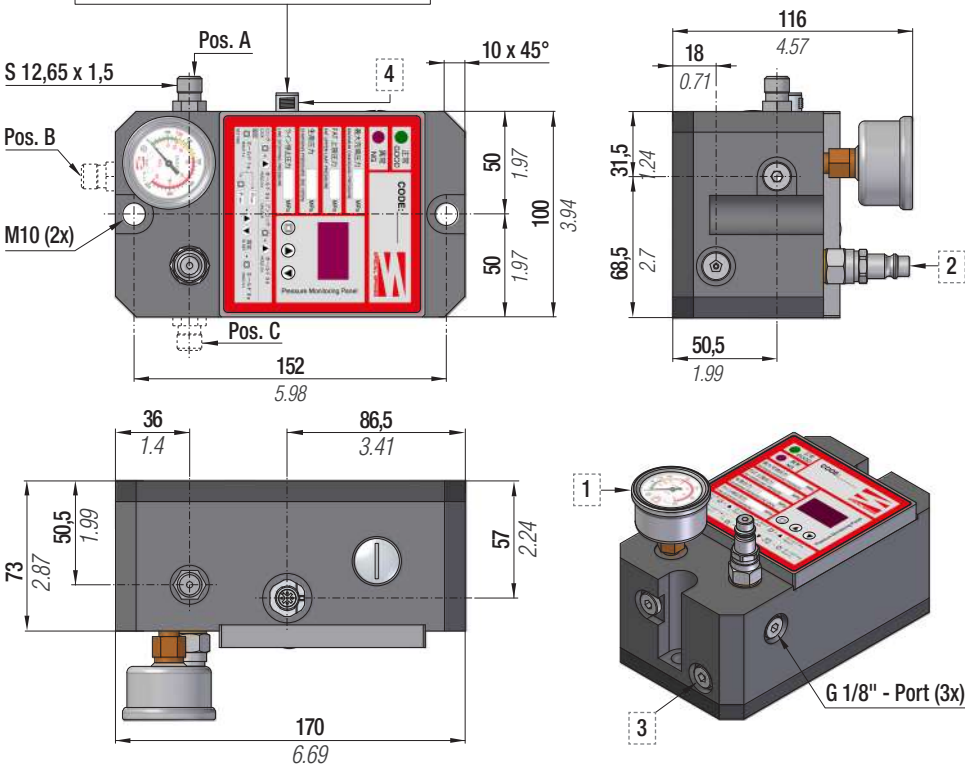

HOW TO ORDER

code	Cable
39CP17A.1	+ 59CR02A
Fitting position	

Technical data	
Electrical connector type	M12x1 (5-pin) male Reverse key (B-Code)
Pressure connection	S12,65x1,5
Nominal pressure	0 - 350 bar
Temperature range	- 20°C... + 60°C
Degree of protection as per IEC 60529	IP65 when connected
Supply voltage	12...24 V DC 100...120 V AC 50...60Hz
Max Output relay current (2-4 wire)	2A 1A
Max current	230mA

Always depressurize and disconnect control panel from the power supply before establishing an electrical connection.

Electrical connections	12...24 V DC	100...120 V AC 50...60Hz	Wire connections color
1	+	1	Brown
3	-	3	Blue
2	Output relay - Normally Open		White
4			Black
5	Ground		Green / Yellow

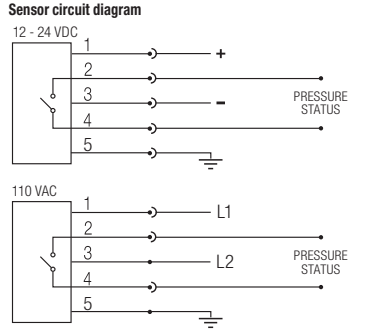

1	Manometro 0÷ 600 bar Pressure gauge 0÷ 600 bar Manómetro 0÷ 600 bar Manómetro 0÷ 600 bar Manómetro 0÷ 620 bar	2	Innesto rapido di caricamento Cejn Quick coupling for charging Cejn Steckegel Cejn Accouplement rapide mâle Cejn Acoplamiento rápido para carga Cejn União rápida para carregamento Cejn	3	Tappo di sicurezza sovrappressione CE Overpressure safety plug CE Überdruck Sicherheitsstecker CE Bouchon de sécurité surpression CE Enchufe de seguridad sobrepresión CE Bujão de segurança sobrepressão CE	4	Connettore elettrico Electrical connector Elektrische Connecteur électrique Eléctrica Conector Conector elétrico
---	---------------------------------------------------------------------------------------------------------------------------	---	---------------------------------------------------------------------------------------------------------------------------------------------------------------------------------------------------------	---	-----------------------------------------------------------------------------------------------------------------------------------------------------------------------------------------------------------------------------	---	---------------------------------------------------------------------------------------------------------------------------------



CONTROL PANEL CP23A



IT
Pannello di controllo con base in alluminio provvisto di sensore di pressione EYE, valvola di caricamento e scaricamento, tappo di rottura sovrappressione, protezione in acciaio, innesto rapido di caricamento Cejn e 3 uscite da 1/8" gas per gestione sistemi collegati.

EN
Control panel with aluminium base, equipped with pressure sensor EYE, charging and discharging valve, overpressure rupture plug, steel protective cover, Cejn-quick coupling for charging and three G 1/8" ports for managing linked systems.

DE
Kontrollarmatur mit Aluminiumgehäuse mit Drucksensor EYE, Befüll- und Ablassventil, Überdruck-Berstsicherung, Schutzabdeckung aus Stahl, Cejn-Schnellkupplung zur Befüllung, und drei G1/8" Anschlussgewinden zur Steuerung von Verbundsystemen.

FR
Panneau de contrôle avec base en aluminium, équipé du capteur de pression EYE, valve de chargement-déchargement, bouchon de rupture pour surpression, couverture de protection en acier, raccord rapide Cejn pour le chargement et trois ports G 1/8" pour la gestion des systèmes connectés.

ES
Panel de control con base de aluminio equipado con sensor de presión EYE, válvula de carga y descarga, tapón de rotura por sobrepresión, protección de acero, acoplamiento rápido Cejn y 3 salidas 1/8" gas para gestión de sistemas conectados.

PT
Painel de controle com base em alumínio, fornecido com o sensor de pressão EYE, válvula de carregamento e descarregamento, bujão de ruptura para sobrepressão, cobertura protetora em aço, engate rápido de carregamento CEJN e 3 saídas G1/8" para a gestão de sistemas de mangueiras.

code	Pressure Gauge	Rupture Plug	Easy Manifold
39CP23A	bar/psi/MPa	✓	✓

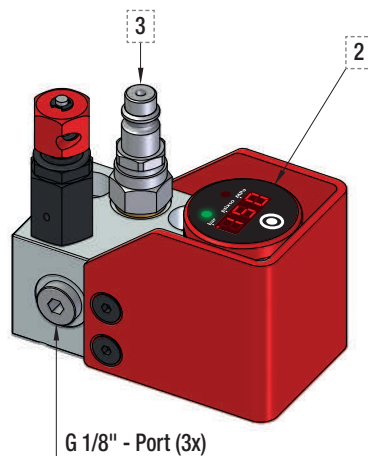
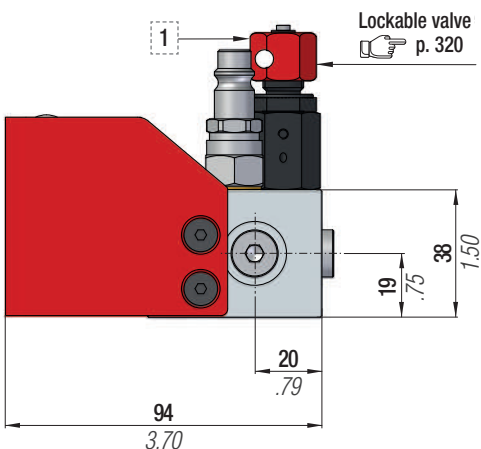
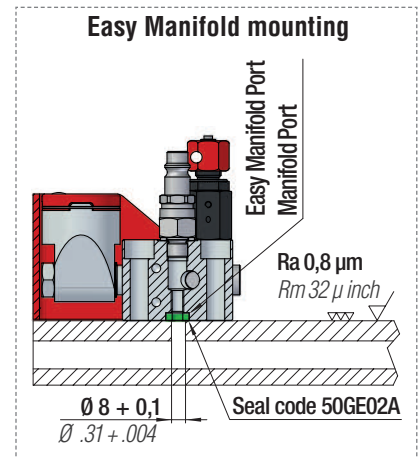
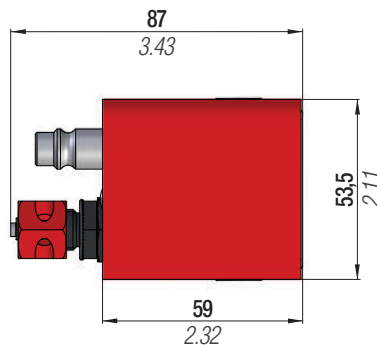
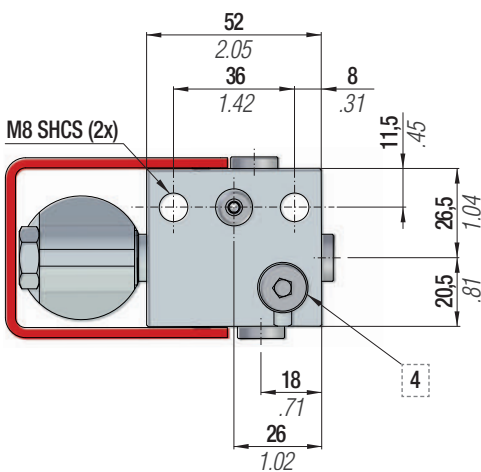

Technical data	
Measuring range	0 ÷ 600 bar / 8700 psi / 60 MPa
Visualization	3 digit display + 2 led
Resolution	1 bar, 10 psi, 1 MPa
Measurement unit	bar, psix10, MPa
Accuracy	±1,0% f.s., ±1 digit whichever is greater
Working temperature	0 ÷ 80°C / 176°F
Compatible fluids	Nitrogen
Battery	Maxell CR2032-3V, 220mAh
Material	Stainless steel/Aluminum alloy
Connection	G1/8"
Alarms	Low pressure (adjustable), High pressure (fixed), Sensor malfunction, Low battery
Battery lifetime	> 2000 readings
Degree of protection	IP65 when connected

1	Valvola di scarico Discharging valve Auslaßventil Valve de déchargement Válvula de descarga Válvula de descarga	2	Sensore di pressione EYE EYE Pressure Sensor Drucksensor EYE Capteur de pression EYE Sensor de presión EYE Sensor de pressão EYE	3	Innesto rapido di caricamento Cejn Quick coupling for charging Cejn Steckkegel Cejn Accouplement rapide mâle Cejn Acoplamiento rápido para carga Cejn União rápida para carregamento Cejn	4	Tappo di rottura sovrappressione Over pressure rupture plug Überdruck-Bruchstecker Bouchon de rupture de surpression Enchufe de ruptura de sobrepresión Plugue ruptura sobrepressão
---	--------------------------------------------------------------------------------------------------------------------------------	---	-------------------------------------------------------------------------------------------------------------------------------------------------	---	----------------------------------------------------------------------------------------------------------------------------------------------------------------------------------------------------------	---	----------------------------------------------------------------------------------------------------------------------------------------------------------------------------------------------------



THIS PAGE IS INTENTIONALLY LEFT BLANK



DISTRIBUTION BLOCKS

code 39BD0301B

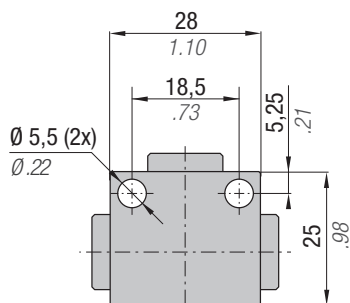

code 39BD0401A

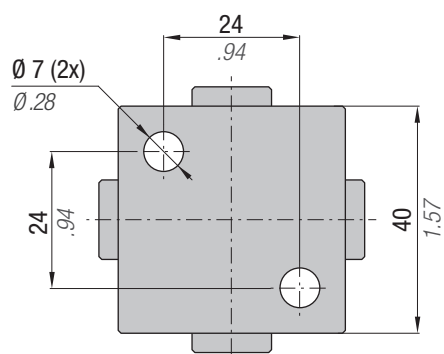

code 39BD0402A

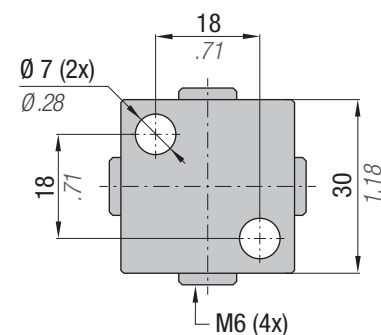

code 39BD06A

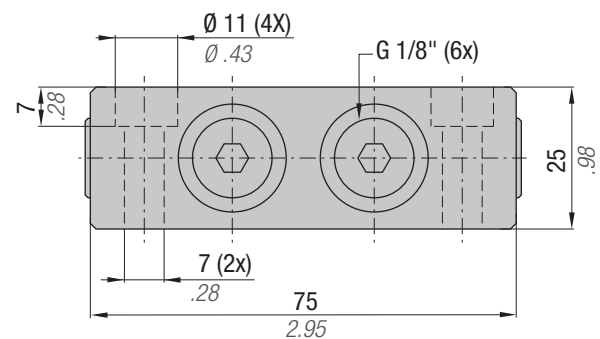
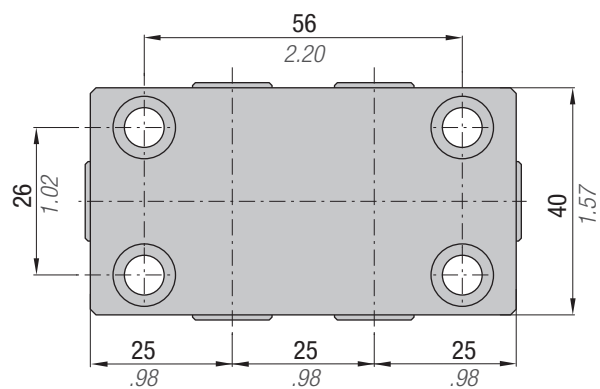

code 39BD0601A

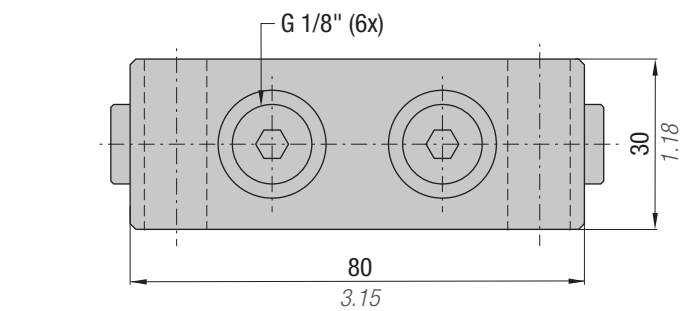
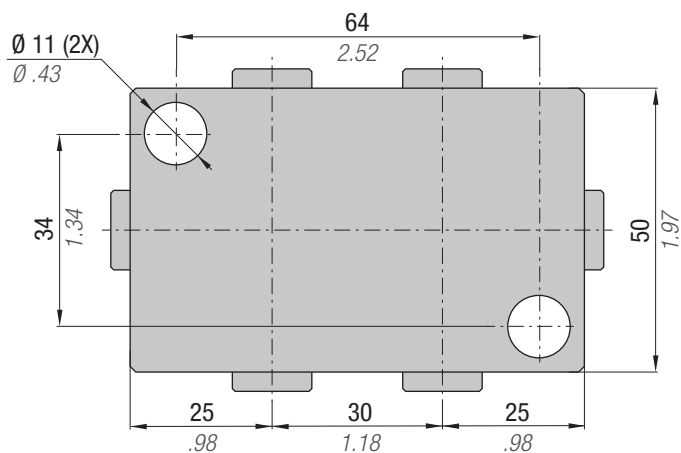

code 39BD06/1

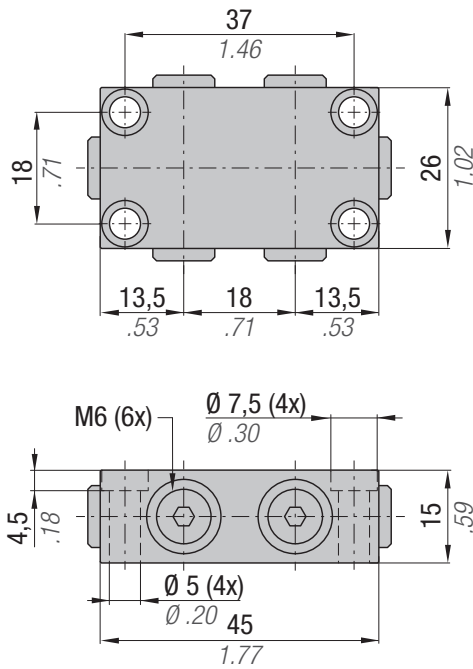

code 39BD06/2

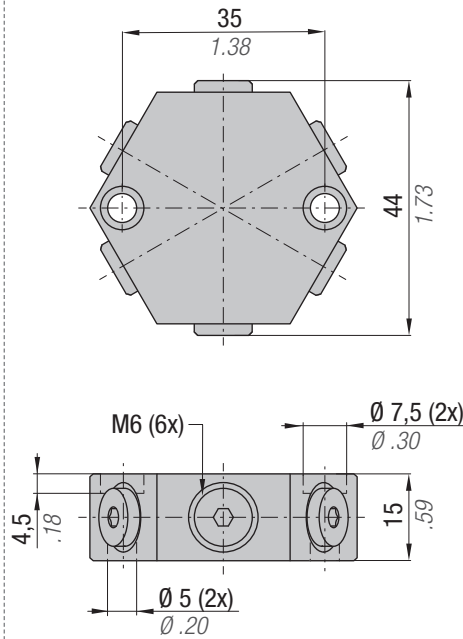

code 39BD0603A

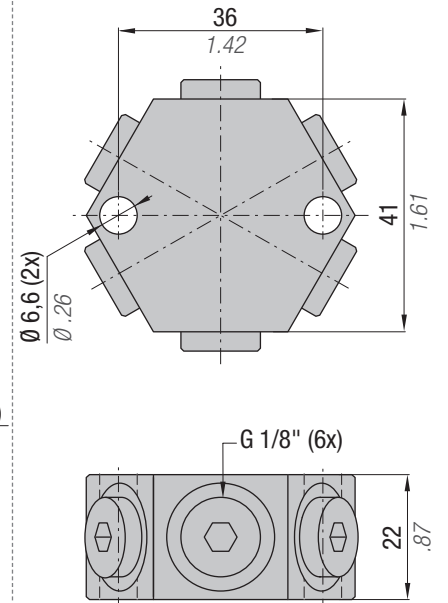

code 39BD0801A

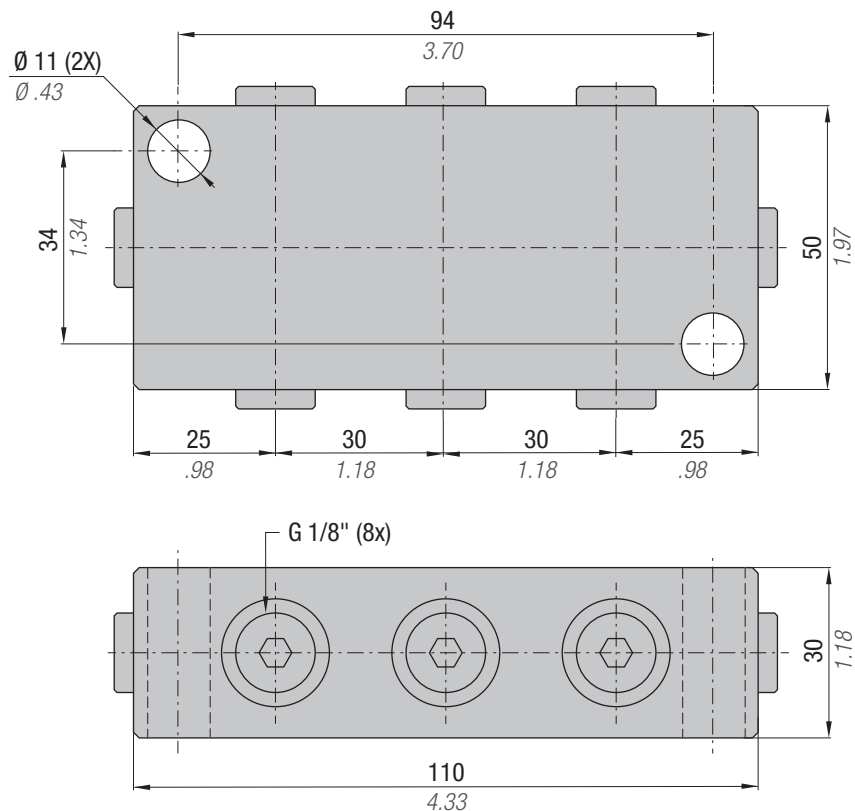

All dimensions in mm/inch



DISTRIBUTION BLOCKS



code 39BD10A

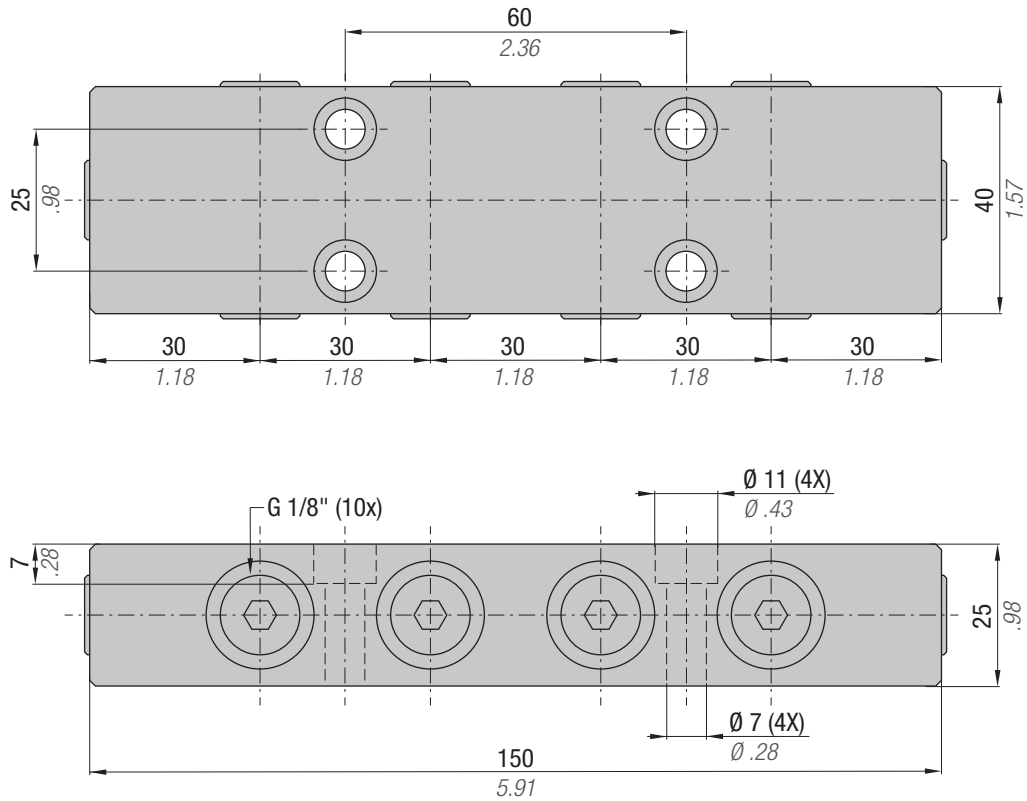

code 39BD1001A

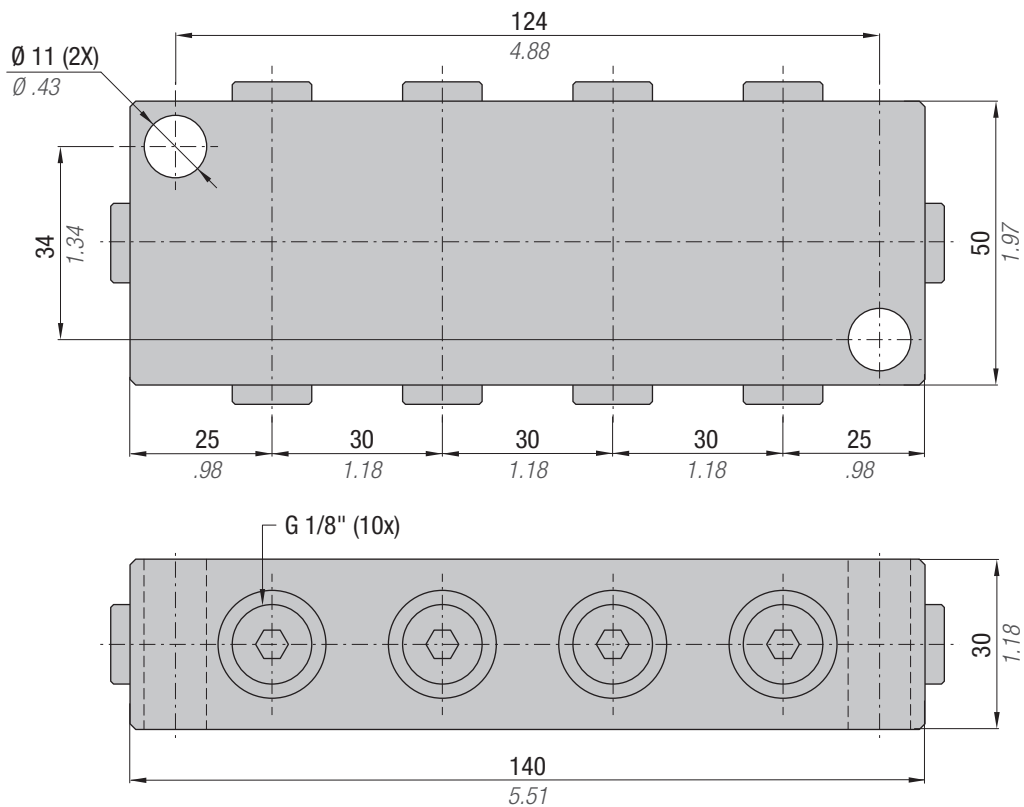

code 39BD1201A

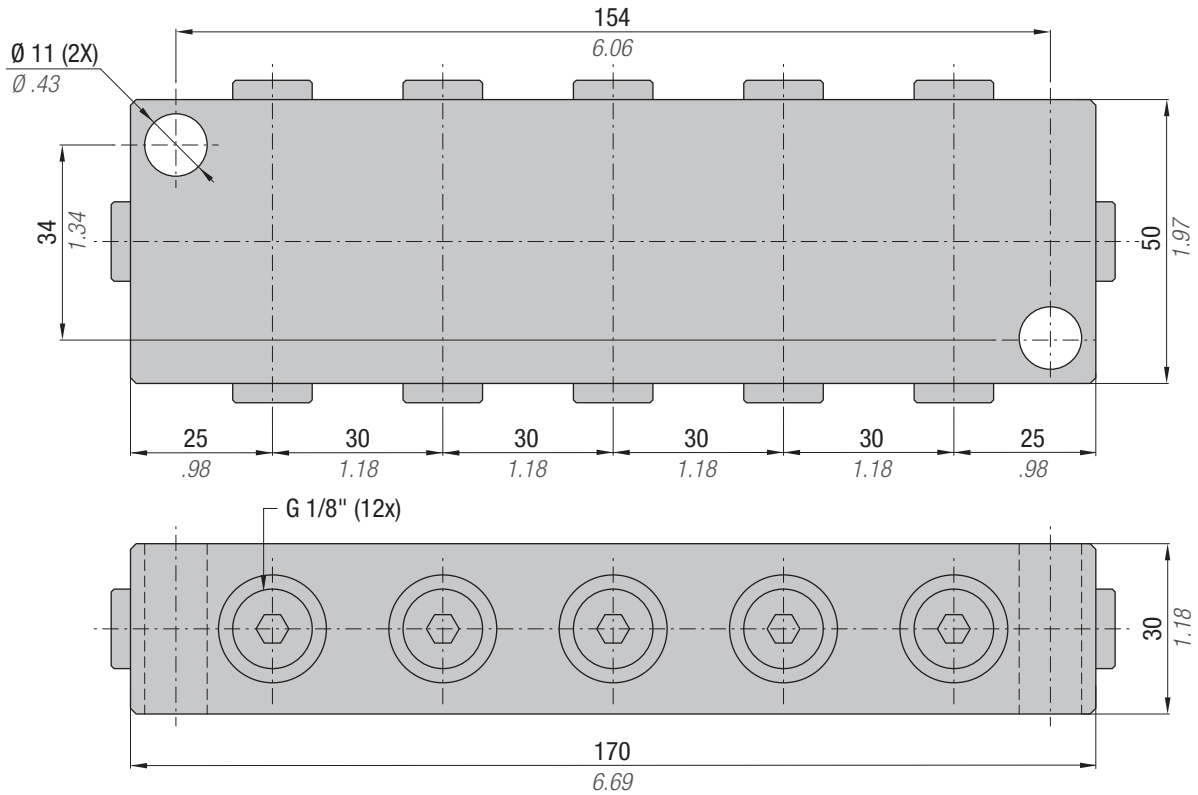

code 39BD1401A

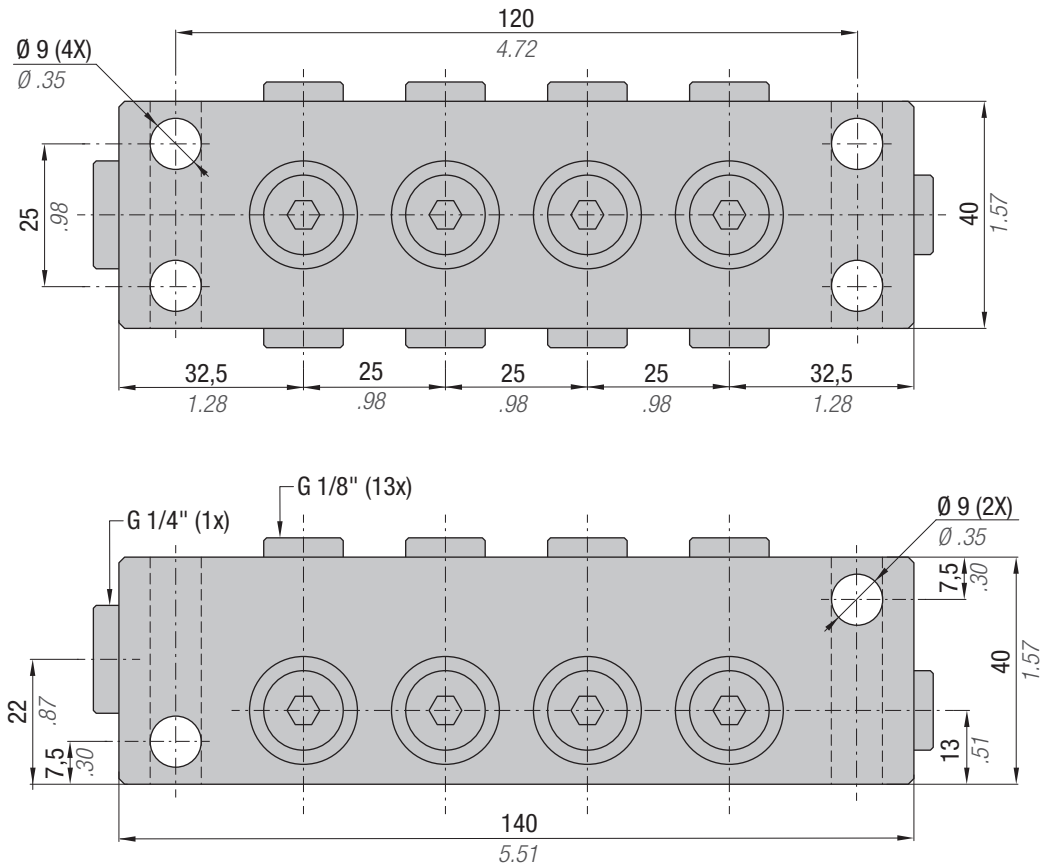

All dimensions in mm/inch



IT Nel modo di funzionamento non autonomo i cilindri possono essere collegati ad un polmone di compensazione esterno. Lo scopo principale è contenere l'aumento di pressione nel sistema entro limiti prefissati e minori rispetto al normale incremento dato dalla compressione degli steli-pistoni. La determinazione del volume di compensazione richiesto è facilmente calcolabile applicando la seguente formula:

$$V_p = n \cdot \{[S \cdot x \cdot R / (R-1)] - V_0\}$$

V_p = volume del polmone [cm³]

n = numero di cilindri componenti il sistema

S = sezione dello stelo (pistone per serie KE) di ogni singolo cilindro [cm²]

x = corsa effettiva di lavoro [cm]

R = rapporto tra pressione finale ed iniziale del sistema [max 1,4]

V_0 = volume iniziale di ogni singolo cilindro [cm³]

Esempio:

Forza richiesta ~6000 daN ed $R=1,1$ (10%). Si scelgono n. 4 SC1500-50 (oppure n. 2 SC3000-50) Il volume richiesto è di circa 1300 cm³ e quindi la scelta sarà per il polmone tipo PC-3. Un eventuale maggior volume del polmone non è un problema. Inoltre possono essere collegati tra loro più polmoni di compensazione per ottenere volumi più prossimi a quelli richiesti

EN Gas cylinders operating in non self-contained mode may be connected to a compensation tank. The principal aim is to limit the pressure within the system to a lower figure than would normally be obtained with standard compression rates. The compensation tank volume may be easily found using the following formula:

$$V_p = n \cdot \{[S \cdot x \cdot R / (R-1)] - V_0\}$$

V_p = compensation volume [cm³]

n = no. of gas cylinders required.

S = Area of rod (piston for series KE) in [cm²]

x = effective working stroke in [cm]

R = Ratio between final required pressure and initial pressure of the system [max 1,4]

V_0 = Initial volume of each cylinder in [cm³]

Example:

Force required ~6000 daN and $R = 1,1$ (10%). No. of cylinders = 4 Type SC1500-50 (or 2 Type SC3000-50). The compensation volume required is approximately 1300 cm³. Therefore, the compensation tank required will be type PC-3. Extra volume in the tank is generally not a problem, and to obtain more accurate volume, extra tanks may be connected in the system

DE Im gesteuerten, nicht-autonomen Funktionsmodus können die Zylinder an einen Ausgleichspeicher angeschlossen werden. Hauptzweck ist es, den Druckaufbau im System innerhalb der vorgegebenen Grenzwerte und unterhalb der normalen Zunahme durch den Druck der Kolbenstangen zu halten. Die Bestimmung des notwendigen Ausgleichvolumens kann mit folgender Formel leicht errechnet werden:

$$V_p = n \cdot \{[S \cdot x \cdot R / (R-1)] - V_0\}$$

V_p = Speichervolumen [cm³]

n = Anzahl der Zylinder im System

S = Stangenquerschnitt (Kolben für Serie KE) jedes einzelnen Zylinders [cm²]

x = tatsächlicher Arbeitshub [cm]

R = Verhältnis zwischen Anfangs- und Enddruck des Systems [max 1,4]

V_0 = Anfangsvolumen jedes einzelnen Zylinders [cm³]

Beispiel:

Benötigte Kraft ca. 6000 daN, $R = 1,1$ (10%) Nr. 4 SC1500-50 (oder Nr. 2 SC3000-50) Das benötigte Volumen beträgt ca. 1300 cm³, die Wahl des Speichers fällt daher auf den Typ PC-3. Auch ein eventuelles höheres Speicher volumen stellt kein Problem dar. Außerdem können mehrere Ausgleichspeicher aneinander geschlossen werden, um die benötigten Volumina zu erhalten

FR Dans le mode de fonctionnement non autonome, les vérins peuvent être reliés à un réservoir de compensation.

L'objectif principal est de contenir l'élévation de la pression, dans le système, dans les limites préétablies et inférieures par rapport à l'augmentation normale provoquée par la compression des tiges-pistons.

La détermination du volume de compensation requis se calcule facilement en utilisant la formule suivante:

$$V_p = n \cdot \{[S \cdot x \cdot R / (R-1)] - V_0\}$$

V_p = volume du réservoir [cm³]

n = nombre de vérins composant le système

S = section de la tige (piston pour série KE) de chaque vérin [cm²]

x = course réelle de travail [cm]

R = rapport entre pression finale et initiale du système [max 1,4]

V_0 = volume initial de chaque vérin [cm³]

Exemple:

Force requise env. 6000 daN et $R = 1,1$ (10%) 4 SC1500-50 (ou bien 2 SC3000-50) Le volume requis est d'environ 1300 cm³ et le choix se portera donc sur le réservoir de type PC-3. A noter qu'un plus grand volume éventuel du réservoir ne représente pas un problème. De plus, les réservoirs peuvent être couplés pour obtenir les volumes voisinant ceux requis.

ES Los cilindros de gas en funcionamiento no autónomo pueden conectarse a un pulmón de compensación. El objetivo principal es limitar la presión del sistema, reduciéndola a un valor menor que el que normalmente se obtendría con tasas de compresión standard. El volumen del pulmón de compensación puede calcularse fácilmente mediante la siguiente fórmula:

$$V_p = n \cdot \{ [S \cdot x \cdot R / (R-1)] - V_0 \}$$

V_p = volumen de compensación [cm³]
 n = nº de cilindros de gas existentes en el sistema.
 S = Área del vástago (pistón en la serie KE) de cada cilindro en [cm²]
 x = carrera efectiva en [cm]
 R = Cociente entre la presión final necesaria y la presión inicial del sistema [max 1,4]
 V_0 = Volumen inicial de cada cilindro en [cm³]

Ejemplo:

Fuerza necesaria ~6000 daN y $R = 1,1$ (10%).

Nº de cilindros = 4 Tipo SC1500-50 (ó 2 Tipo SC3000-50). El volumen de compensación necesario es de aproximadamente 1300 cm³.

Por lo tanto, el pulmón de compensación será del tipo PC-3. Por lo general, un pulmón con volumen extra no constituye problema. Para obtener un volumen más exacto, puede ser necesario conectar más pulmones al sistema

PT Os cilindros de gás que operam em modo não autónomo podem ser ligados a um depósito de compensação. O principal objectivo é limitar o aumento de pressão dentro do sistema a um valor inferior ao que se obteria normalmente com taxas de compressão normalizadas. O volume do depósito de compensação pode ser facilmente determinado utilizando a fórmula seguinte:

$$V_p = n \cdot \{ [S \cdot x \cdot R / (R-1)] - V_0 \}$$

V_p = volume de compensação [cm³]
 n = nº de cilindros de gás necessários.
 S = Área do embolo (pistão para a série KE) em [cm²]
 x = curso de trabalho efectivo em [cm]
 R = Relação entre a pressão final requerida e a pressão inicial do sistema [max 1,4]
 V_0 = Volume inicial de cada cilindro em [cm³]

Exemplo:

Força requerida ~6000 daN e $R = 1,1$ (10%).

Nº de cilindros = 4 Tipo SC1500-50 (ou 2 Tipo SC3000-50). O volume de compensação requerido é de aproximadamente 1300 cm³. Logo,

o depósito de compensação requerido é do tipo PC-3. O volume suplementar no depósito não é geralmente um problema e, para obter um volume mais preciso, podem ser ligados ao sistema depósitos suplementares

Codice Code Bestallnr. Code Codigo Código	Ø D		L		A		H		HT		B		Faccia X X Side Seite X Face X Cara X Face X	Faccia Y Y Side Seite Y Face Y Cara Y Face Y	C	Raccordi Fittings Anschlüsse Raccords Racores Ligações	Volume Volume Volumen Volume Volumen Volume		PED 2014/68/EU	
	mm	inch	mm	inch	mm	inch	mm	inch	mm	inch	mm	inch					cm ³	in ³		
39PC001A	100	3.94	290	11.42	90	3.54	58	2.28	140	5.51	125	4.20	G1/8" (3x)	G1/8" (4x)	40	1.57		1000	61.02	✓
39PC003A	150	5.91	310	12.20	136	5.35	83	3.27	190	7.48	172	6.77	G1/8" (4x)	G1/8" (4x)	70	2.76	RTC	3000	183.07	✓
39PC005A	150	5.91	475	18.70	136	5.35	83	3.27	190	7.48	172	6.77	G1/8" (4x)	G1/8" (4x)	70	2.76	RMTC	5000	305.12	✓
39PC008A	200	7.87	415	16.34	212	8.35	108	4.25	242	9.53	252	9.92	G1/8" (6x)	G1/8" (6x)	97	3.82	RSMPD	8000	488.18	✓
39PC010A	200	7.87	505	19.88	212	8.35	108	4.25	242	9.53	252	9.92	G1/8" (6x)	G1/8" (6x)	97	3.82		9960	607.79	✓

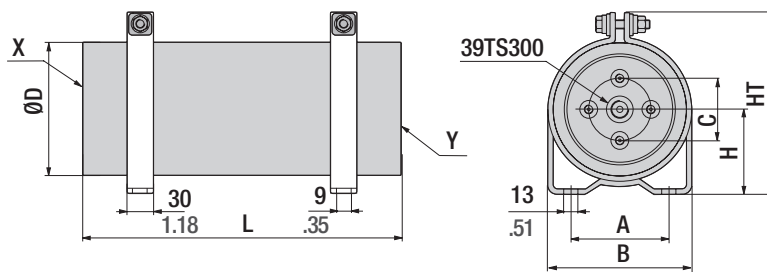

code: 39TS300 (300 bar)

Tappo di sicurezza sovrappressione CE
 Overpressure safety plug CE
 Überdruck Sicherheitsstecker CE
 Bouchon de sécurité surpression CE
 Enchufe de seguridad sobrepresion CE
 Bujão de segurança sobrepressão CE

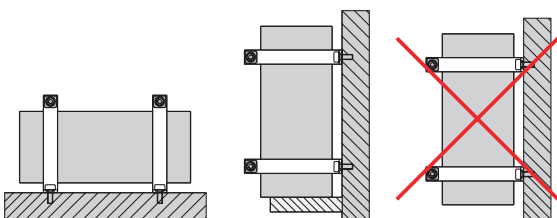
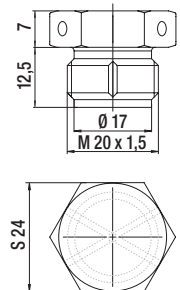

IT Pressione massima di caricamento: 150 bar
 Massima pressione di lavoro: 220 bar

EN Maximum charging pressure: 150 bar
 Maximum working pressure: 220 bar

DE Max. Fülldruck: 150 bar
 Maximaler Arbeitsdruck: 220 bar

FR Pression maximale: 150 bar
 Pression de service maximale: 220 bars

ES Presión máxima de carga: 150 bar
 Presión máxima de trabajo: 220 bar

PT Pressão máxima de carregamento: 150 bar
 Pressão máxima de trabalho: 220 bar



All dimensions in mm/inch

AIR SYSTEMS TANKS



- IT** Le tabelle sotto riportate devono essere utilizzate, in fase di progettazione, per determinare il numero, il volume e le dimensioni dei serbatoi aria a bordo stampi. Tabella volumi (litri): volume d'aria necessario per cilindro ad azoto in relazione al diametro e alla corsa.
- EN** The tables below must be used, during design, to define the number, volume and sizes of the air tanks on the dies. Volume table (litres): volume of air needed for the pneumatic cylinder in relation to the diameter and stroke.
- DE** Die untenstehenden Tabellen werden in der Planungsphase für die Bestimmung der Anzahl, des Volumens und der Abmessung der Luftbehälter am Rand der Formen benutzt. Tabelle der Volumen (Liter): Das für Pneumatikzylinder in Bezug auf Durchmesser und Hub notwendige Luftvolumen.
- FR** Les tableaux reportés ci-dessous doivent être utilisés, lors de la conception, pour déterminer le nombre, le volume et les dimensions des réservoirs d'air sur le bord des moules. Tableau des volumes (litres) : volume d'air nécessaire par cylindre pneumatique par rapport au diamètre et à la course.
- ES** Las tablas propuestas abajo deben ser utilizadas, en la fase de diseño, para determinar el número, el volumen y las dimensiones de los tanques de aire de los utilajes. Tabla de volúmenes (litros): volumen de aire necesario por cada cilindro de nitrógeno en relación al diámetro y a la carrera.
- PT** As tabelas abaixo devem ser usadas na fase de design de forma a determinar o número, o volume e o tamanho do reservatório de ar da ferramenta.

Cilindri pneumatici Pneumatic Cylinders Pneumatikzylinder Vérins pneumatiques Cilindros neumáticos Cilindros pneumáticos		Corse standard - Standard Strokes - Standardhübe - Course standard - Carreras estándar - Cursos standard																	
		mm inch																	
		25	0.98	40	1.57	50	1.97	60	2.36	75	2.95	100	3.94	125	4.92	150	5.91	175	6.89
		Volume - Volume - Volumens - Volume - Volumen - Volume																	
		dm ³ in ³																	
mm	inch																		
Ø 32	Ø 1.26	0,020	1.220	0,032	1.953	0,040	2.441	0,048	2.929	0,060	3.661	0,080	4.882	0,100	6.102	0,120	7.323	0,140	8.543
Ø 40	Ø 1.57	0,031	1.892	0,050	3.051	0,063	3.844	0,075	4.577	0,094	5.736	0,126	7.689	0,157	9.581	0,189	11.533	0,221	13.486
Ø 50	Ø 1.97	0,049	2.990	0,078	4.760	0,098	5.980	0,118	7.201	0,147	8.970	0,196	11.961	0,245	14.951	0,294	17.941	0,343	20.931
Ø 63	Ø 2.48	0,078	4.760	0,125	7.628	0,158	9.642	0,187	11.411	0,234	14.280	0,312	19.039	0,390	23.799	0,488	29.780	0,546	33.319
Ø 80	Ø 3.15	0,126	7.689	0,201	12.266	0,251	15.317	0,302	18.429	0,377	23.006	0,503	30.700	0,528	32.221	0,754	46.012	0,880	53.701
Ø 100	Ø 3.94	0,196	11.961	0,314	19.161	0,393	23.982	0,471	28.742	0,589	35.943	0,785	47.904	0,982	59.925	1,177	71.825	1,374	83.847
Ø 125	Ø 4.92	0,308	18.795	0,491	29.963	0,614	37.469	0,738	45.036	0,920	56.142	1,227	74.876	1,534	93.610	1,841	112.34	2,147	131.02
Ø 160	Ø 6.30	0,502	30.634	0,804	49.063	1,005	61.329	1,208	73.717	1,508	92.024	2,010	122.66	2,513	153.35	3,016	184.05	3,519	214.74
Ø 200	Ø 7.87	0,785	47.904	1,257	76.707	1,571	95.868	1,885	115.03	2,356	143.77	3,142	191.74	3,928	239.70	4,712	287.54	5,498	335.51

- IT** Per cilindri pneumatici funzionanti a doppio effetto (d.e.) determinare il volume attraverso la tabella. Per cilindri pneumatici funzionanti a semplice effetto (s.e.) determinare sempre il volume tramite la tabella e moltiplicare il risultato ottenuto per 3. Sommare tutti i volumi dei vari cilindri pneumatici a bordo stampo per ricavare la capacità totale (dm³) del serbatoio. Scegliere il serbatoio in relazione alla capacità totale ricavata (dm³) ed allo spazio disponibile sullo stampo.
- EN** For double acting pneumatic cylinders (d.e.) use the table to define the volume. For single-acting pneumatic cylinders (s.e.) still use the table to define the volume and multiply the result obtained by 3. Add all the volumes of the various pneumatic cylinders on the die to obtain the total capacity (dm³) of the tank. Choose the tank in relation to the total capacity obtained (dm³) and to the space available on the die.
- DE** Für Pneumatikzylinder mit Doppelleffekt (d.e.) wird das Volumen auf Grund der Tabelle bestimmt. Für Pneumatik Zylindern mit Einzeleffekt (s.e.) immer das Volumen aufgrund der Tabelle bestimmen, dann das Ergebnis mit 3 multiplizieren. Alle Volumen der verschiedene Pneumatik Zylindern am Form summen, um das totale Fassungsvermögen des Tanks (dm³) zu erzielen. Den Tankbehälter gemäß dem bestimmten Fassungsvermögen (dm³) und gemäß dem verfügbaren Raum auf der Form auswählen.
- FR** Pour les cylindres pneumatiques fonctionnant à double effet (d.e.), déterminer le volume au moyen du tableau. Pour les cylindres pneumatiques fonctionnant à effet simple (s.e.), déterminer toujours le volume au moyen du tableau et multiplier le résultat obtenu par 3. Sommer tous les volumes des différents cylindres pneumatiques sur le bord du moule pour obtenir la capacité totale (dm³) du réservoir. Choix du réservoir par rapport à la capacité totale obtenue (dm³) et à l'espace disponible sur le moule.
- ES** Para cilindros neumáticos de doble efecto (d. e.) determinar el volumen por medio de la tabla. Para cilindros neumáticos de simple efecto (s. e.) determinar siempre el volumen por medio de la tabla y multiplicar el resultado obtenido por 3. Sumar todos los volúmenes de los diferentes cilindros neumáticos del útil para calcular la capacidad total (dm³) del depósito. Seleccionar el depósito en relación a la capacidad total obtenida (dm³) y al espacio disponible en el troquel.
- PT** Para cilindros pneumáticos de duplo efeito (d.e), o volume deve ser determinado de acordo com a tabela. Para cilindros pneumáticos de efeito único, o volume deve ser determinado de acordo com a mesma tabela. o resultado deve ser multiplicado por 3. Para saber a capacidade total (litros) do reservatório, deve somar todos os volumes dos cilindros pneumáticos. A escolha da capacidade do reservatório, está relacionada com o cálculo da capacidade total (litros) e o espaço disponível na ferramenta.

All dimensions in mm/inch

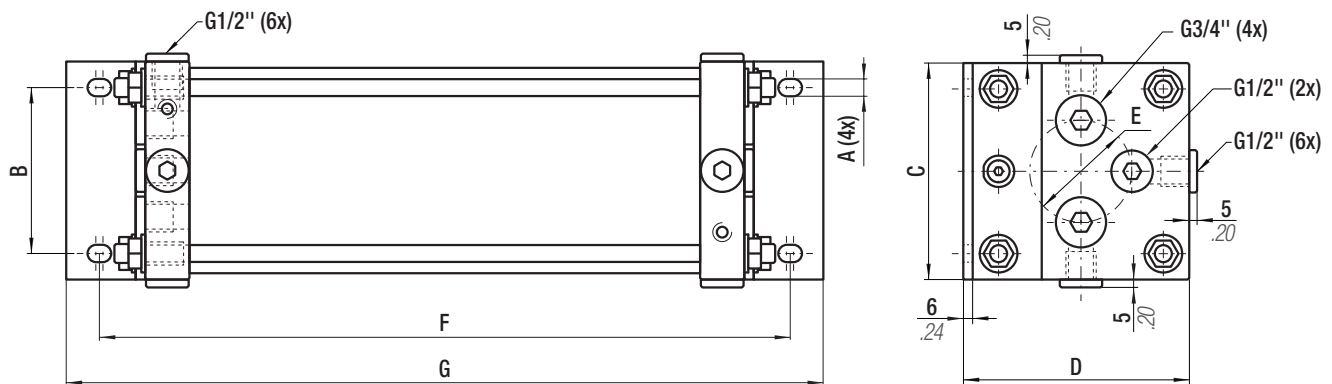

Codice Code Bestallnr. Code Codigo Código	Volume		A		B		C		D		E		F		G		Peso Weight Gewicht Poids Peso Peso		PED 2014/68/EU
	dm ³	in ³	mm	inch	mm	inch	mm	inch	mm	inch	mm	inch	mm	inch	mm	inch	~Kg	~lb	
	39SRA1003A	3	0.12	11	.43	105	4.13	138	5.43	144	5.67	65	2.56	382	15.04	424	16.69	14,0	
39SRA1004A	4	0.16	11	.43	105	4.13	138	5.43	144	5.67	65	2.56	471	18.54	513	20.20	15,7	34.6	✓
39SRA1005A	5	0.20	11	.43	105	4.13	138	5.43	144	5.67	65	2.56	560	22.05	602	23.70	17,4	38.4	✓
39SRA1006A	6	0.24	11	.43	105	4.13	138	5.43	144	5.67	65	2.56	649	25.55	691	27.20	19,1	42.1	✓
39SRA1008A	8	0.31	11	.43	105	4.13	138	5.43	144	5.67	65	2.56	827	32.56	869	34.21	22,5	49.6	✓
39SRA2003A	3	0.12	13	.51	127	5.00	168	6.61	174	6.85	80	3.15	298	11.73	328	12.91	17,2	37.9	✓
39SRA2004A	4	0.16	13	.51	127	5.00	168	6.61	174	6.85	80	3.15	355	13.98	385	15.16	18,4	40.6	✓
39SRA2005A	5	0.20	13	.51	127	5.00	168	6.61	174	6.85	80	3.15	412	16.22	442	17.40	19,7	43.4	✓
39SRA2006A	6	0.24	13	.51	127	5.00	168	6.61	174	6.85	80	3.15	469	18.46	499	19.65	21,0	46.3	✓
39SRA2008A	8	0.31	13	.51	127	5.00	168	6.61	174	6.85	80	3.15	583	22.95	613	24.13	23,6	52.0	✓
39SRA2010A	10	0.39	13	.51	127	5.00	168	6.61	174	6.85	80	3.15	697	27.44	727	28.62	26,2	57.8	✓
39SRA2012A	12	0.47	13	.51	127	5.00	168	6.61	174	6.85	80	3.15	811	31.93	841	33.11	28,7	63.3	✓
39SRA3004A	4	0.16	13	.51	163	6.42	218	8.58	224	8.82	120	4.72	255	10.04	285	11.22	26,3	58.0	✓
39SRA3005A	5	0.20	13	.51	163	6.42	218	8.58	224	8.82	120	4.72	287	11.30	317	12.48	27,3	60.2	✓
39SRA3006A	6	0.24	13	.51	163	6.42	218	8.58	224	8.82	120	4.72	319	12.56	389	15.31	28,3	62.4	✓
39SRA3008A	8	0.31	13	.51	163	6.42	218	8.58	224	8.82	120	4.72	383	15.08	413	16.26	3,3	66.8	✓
39SRA3010A	10	0.39	13	.51	163	6.42	218	8.58	224	8.82	120	4.72	447	17.60	477	18.78	32,4	71.4	✓
39SRA3012A	12	0.47	13	.51	163	6.42	218	8.58	224	8.82	120	4.72	511	20.12	541	21.30	34,4	75.8	✓
39SRA3015A	15	0.59	13	.51	163	6.42	218	8.58	224	8.82	120	4.72	607	23.90	637	25.08	37,4	82.5	✓
39SRA3018A	18	0.71	13	.51	163	6.42	218	8.58	224	8.82	120	4.72	701	27.60	733	28.86	40,4	89.0	✓
39SRA3022A	22	0.87	13	.51	163	6.42	218	8.58	224	8.82	120	4.72	837	32.95	861	33.90	44,4	97.9	✓



50°C	122°F	Temperatura max esercizio - Max. operating temperature - max. Betriebstemperatur Température maximum de fonctionnement - Temperatura máx. de funcionamiento - Tempepratura Max operacional.
15 bar	218 psi	P. max esercizio - Maximum operating pressure - max: Betriebsdruck Pression Max de Fonctionnement - Presión máxima de funcionamiento - Pressão máxima de operação.
25 bar	363 psi	Pressione di collaudo - Testing pressure - Druckprüfung Pression d'essais - Presión de prueba - Pressão de teste.

All dimensions in mm/inch

ACCESSORIES



IT	Piastra di contrasto	Temperato
EN	Counter plate	Hardened
DE	Stellplatten	Gehärtet
FR	Plaques d'appui	Tempéré
ES	Placas de apoyo	Templado
PT	Placas de apoi	Temperado

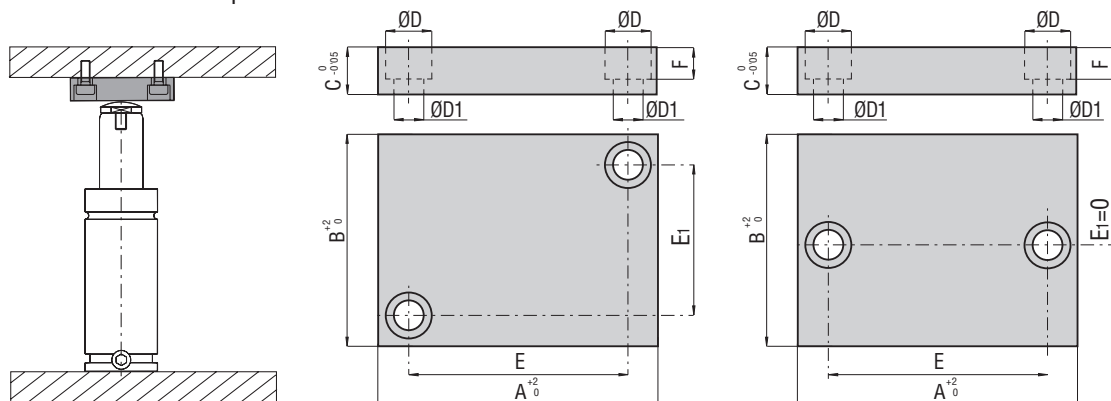

CODE		A		B		C		Ø D		Ø D1		E		E1		F		
PHASING OUT	NEW	mm	inch	mm	inch	mm	inch	mm	inch	mm	inch	mm	inch	mm	inch	mm	inch	
PS040040	39PA040040A ^{1) 5)}	40	1.57	40	1.57	15	0.59	15	0.59	9	0.35	21	0.83	21	0.83	10	0.39	d ≤ 20 0.79
-	39PAB040040A ^{4) 7)}	40	1.57	40	1.57	12	0.47	11	0.43	7	0.28	24	0.94	24	0.94	7	0.28	d ≤ 20 0.79
-	39PAA040040A	40	1.57	40	1.57	15	0.59	11	0.43	7	0.28	24	0.94	24	0.94	7	0.28	d ≤ 20 0.79
PS056056	39PA056056A ^{3) 5)}	56	2.20	56	2.20	20	0.79	18	0.71	11	0.43	32	1.26	32	1.26	13	0.51	d ≤ 36 1.42
-	39PA060060A ^{4) 7)}	60	2.36	60	2.36	15	0.59	15	0.59	9	0.35	40	1.57	40	1.57	9	0.35	d ≤ 36 1.42
-	39PAA060060A ⁶⁾	60	2.36	60	2.36	12	0.47	14	0.55	9	0.35	38	1.5	38	1.5	9	0.35	d ≤ 36 1.42
-	39PA070070A ^{1) 4) 7)}	70	2.76	70	2.76	15	0.59	15	0.59	9	0.35	50	1.97	50	1.97	9	0.35	d ≤ 60 2.36
PS071071	39PA071071A ⁵⁾	71	2.80	71	2.80	20	0.79	18	0.71	11	0.43	48	1.89	48	1.89	13	0.51	d ≤ 60 2.36
-	39PA080080A ²⁾	80	3.15	80	3.15	16	0.63	15	0.59	9	0.35	62	2.44	0	0	10	0.39	d ≤ 65 2.56
-	39PAB090090A	90	3.54	90	3.54	12	0.47	15	0.59	9	0.35	64	2.52	64	2.52	9	0.35	d ≤ 80 3.15
-	39PAA090090A ¹⁾	90	3.54	90	3.54	15	0.59	15	0.59	9	0.35	70	2.76	70	2.76	9	0.35	d ≤ 80 3.15
-	39PA090090A ^{2) 3) 5)}	90	3.54	90	3.54	20	0.79	18	0.71	11	0.43	67	2.64	67	2.64	13	0.51	d ≤ 80 3.15
-	39PAC090090A ⁶⁾	90	3.54	90	3.54	12	0.47	14	0.55	9	0.35	70	2.76	70	2.76	9	0.35	d ≤ 80 3.15
-	39PA100100A ²⁾	100	3.94	100	3.94	16	0.63	15	0.59	9	0.35	82	3.23	0	0	10	0.39	d ≤ 90 3.54
-	39PAA100100A ^{4) 7)}	100	3.94	100	3.94	20	0.79	18	0.71	11	0.43	74	2.91	74	2.91	11	0.43	d ≤ 90 3.54
-	39PAB100100A ⁶⁾	100	3.94	100	3.94	12	0.47	14	0.55	9	0.35	81	3.19	81	3.19	9	0.35	d ≤ 90 3.54
-	39PAA140140A ⁴⁾	140	5.51	140	5.51	20	0.79	18	0.71	11	0.43	110	4.33	110	4.33	11	0.43	d ≤ 130 5.12
-	39PA140140A ^{3) 5)}	140	5.51	140	5.51	20	0.79	18	0.71	11	0.43	110	4.33	110	4.33	13	0.51	d ≤ 130 5.12
PS050025	39PA050025A ^{1) 5)}	50	1.97	25	0.98	12	0.47	11	0.43	7	0.28	32	1.26	8	0.31	8	0.31	d ≤ 15 0.59
39PA050030A ⁵⁾	-	50	1.97	30	1.18	12	0.47	11	0.43	7	0.28	40	1.57	14	0.55	8	0.31	d ≤ 20 0.79
-	39PA050030B ⁵⁾	50	1.97	30	1.18	12	0.47	11	0.43	7	0.28	35	1.38	14	0.55	7	0.28	d ≤ 20 0.79
PS055030	39PA055030A ¹⁾	55	2.17	30	1.18	12	0.47	11	0.43	7	0.28	40	1.57	14	0.55	8	0.31	d ≤ 20 0.79
-	39PA055032A ²⁾	55	2.17	32	1.26	16	0.63	15	0.59	9	0.35	37	1.46	0	0	10	0.39	d ≤ 20 0.79
-	39PA065050A ²⁾	65	2.56	50	1.97	16	0.63	15	0.59	9	0.35	47	1.85	0	0	10	0.39	d ≤ 36 1.42
PS070035	39PA070035A ^{1) 5)}	70	2.76	35	1.38	15	0.59	15	0.59	9	0.35	48	1.89	14	0.55	10	0.39	d ≤ 30 1.18
PS075050	39PA075050A ^{1) 5)}	75	2.95	50	1.97	15	0.59	15	0.59	9	0.35	56	2.2	30	1.18	10	0.39	d ≤ 36 1.42
-	39PA080060A ²⁾	80	3.15	60	2.36	16	0.63	15	0.59	9	0.35	62	2.44	0	0	10	0.39	d ≤ 55 2.17
-	39PAA085060A ⁵⁾	85	3.35	60	2.36	15	0.59	15	0.59	9	0.35	56	2.2	40	1.57	10	0.39	d ≤ 55 2.17
PS085060	39PA085060A ¹⁾	85	3.35	60	2.36	15	0.59	15	0.59	9	0.35	66	2.6	40	1.57	10	0.39	d ≤ 55 2.17
PS100080	39PA100080A ^{1) 5)}	100	3.94	80	3.15	20	0.79	18	0.71	11	0.43	72	2.83	56	2.2	12	0.47	d ≤ 70 2.76
PS110100	39PA110100A ⁵⁾	110	4.33	100	3.94	20	0.79	18	0.71	11	0.43	85	3.35	75	2.95	12	0.47	d ≤ 100 3.94

¹⁾ VDI 3003 ²⁾ Volvo ³⁾ Renault ⁴⁾ Volkswagen ⁵⁾ FCA ⁶⁾ Mercedes Benz ⁷⁾ BMW

All dimensions in mm/inch

IT	Piastra di contrasto	Temperato
EN	Counter plate	Hardened
DE	Stellplatten	Gehärtet
FR	Plaques d'appui	Tempré
ES	Placas de apoyo	Templado
PT	Placas de apoi	Temperado

CODE	Ø A		Ø B		C		D		Ø E		Ø F		
	mm	inch	mm	inch	mm	inch	mm	inch	mm	inch	mm	inch	
▲ 39PA050A ⁸⁾	50	1.97	29,6	1.17	15	0.59	10	0.39	15	0.59	9	0.35	d ≤ 15 0.59
▲ 39PA070A ⁸⁾	70	2.76	45,2	1.78	20	0.79	13	0.51	18	0.71	11	0.43	d ≤ 25 0.98
▲ 39PA094A ⁸⁾	94	3.70	67,8	2.67	20	0.79	13	0.51	18	0.71	11	0.43	d ≤ 50 1.97

8) Fiat

▲ Phasing out

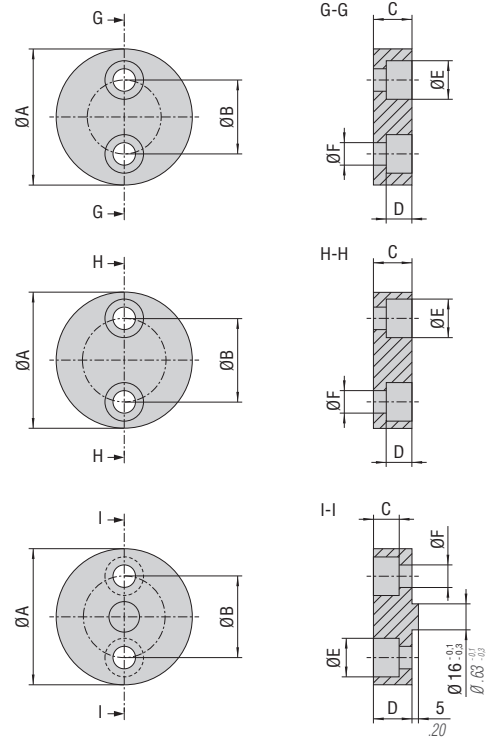

CODE	Ø A		Ø B		C		D		Ø E		Ø F		
	mm	inch	mm	inch	mm	inch	mm	inch	mm	inch	mm	inch	
39PA050B ⁵⁾	50	1.97	21	0.83	15	0.59	10	0.39	15	0.59	9	0.35	d ≤ 15 0.59
39PA070B ⁵⁾	70	2.76	32	1.26	20	0.79	13	0.51	18	0.71	11	0.43	d ≤ 25 0.98
39PA094B ⁵⁾	94	3.70	48	1.89	20	0.79	13	0.51	18	0.71	11	0.43	d ≤ 50 1.97

5) FCA

CODE	Ø A		Ø B		C		D		Ø E		Ø F		
	mm	inch	mm	inch	mm	inch	mm	inch	mm	inch	mm	inch	
39PA098A ⁴⁾	98	3.86	73	2.87	13	0.51	20	0.79	20	0.79	13,5	0.53	d ≤ 50 1.97
39PA113A ⁴⁾	113	4.45	88	3.46	13	0.51	20	0.79	20	0.79	13,5	0.53	d ≤ 65 2.58
39PA128A ⁴⁾	128	5.04	103	4.06	13	0.51	20	0.79	20	0.79	13,5	0.53	d ≤ 80 3.15
39PA143A ⁴⁾	143	5.63	118	4.65	13	0.51	20	0.79	20	0.79	13,5	0.53	d ≤ 95 3.74

4) Volkswagen

code FA 022

IT	Calotta	Temperato
EN	Thrust plates	Hardened
DE	Schaftkappe	Gehärtet
FR	Calotte pour tiges	Tempré
ES	Casquillo para vástagos	Templado
PT	Calote para embolo	Temperado

49 - 52 HRC

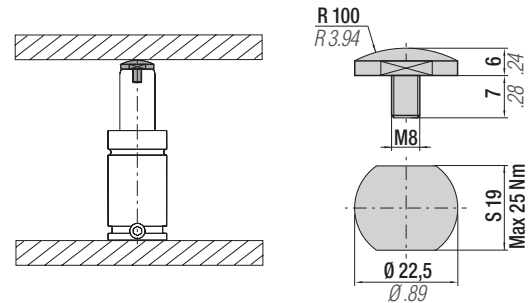

IT	Pressostato	Tensione di lavoro 48 V max	Normalmente aperto
EN	Pressure switch	Operating voltage 48 V max	Normally opened
DE	Druckwächter	Arbeitsspannung 48 V max	Normalerweise offen
FR	Pressostat	Tension d'utilisation 48 V max	Normalement ouvert
ES	Presostato	Tensión de trabajo 48 V max	Normalmente abierto
PT	Pressostato	Tensão de Trabalho 48 V max	Normalmente aberto

PRESSURE SWITCH

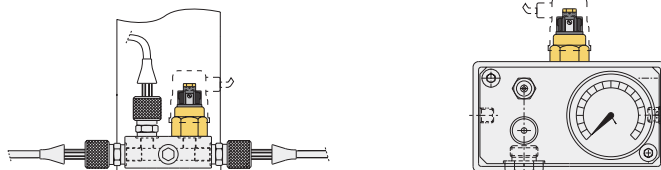

CODE	A	B	C	Range
PMM150A	1/8 " BSPT	59	10	50:150 bar
PMM300A	1/8 " BSPT	59	10	50:300 bar
PMM150A01	1/4 " BSPT	61	12	50:150 bar
PMM300A01	1/4 " BSPT	61	12	50:300 bar

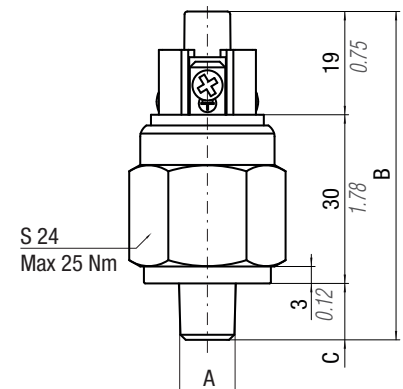

All dimensions in mm/inch

ACCESSORIES



code 39DMB ■



- IT** Dispositivo completo per le operazioni di controllo, riduzione/aumento della pressione o caricamento di cilindri autonomi e sistemi collegati.
- EN** Complete device designed and built for checking operations, decreasing/increasing pressure, or charging self-contained gas springs and linked systems.
- DE** Komplette Vorrichtung zur Kontrolle Operationen, Verminderung / Erhöhung des Drucks, oder Ladung die Selbstständigen gasdruckfedern und verbundenen Systemen.
- FR** Dispositif complet pour les opérations de contrôle, réduction/augmentation de la pression ou chargement de cylindres autonomes et systèmes reliés.
- ES** Dispositivo completo para las operaciones de control, reducción/aumento de la presión o carga de cilindros autónomos y sistemas conectados.
- PT** Dispositivo completo para as operações de controle, redução/aumento da pressão ou carregamento dos cilindros autônomos e sistemas conectados.

Box content:

1	39DMCILA (1 pcs)
2	39DMCPVA (1 pcs) included 39IR01A (1 pcs)
3	ADM01 (1 pcs) - ADM02 (1 pcs) - ADM03 (1 pcs) - ADM04 (1 pcs) - ADM05 (1 pcs) - ADM06 (1 pcs) - ADM08 (1 pcs) - ADM09 (1 pcs) - ADM12 (1 pcs) - ADM13 (1 pcs) - ADM14 (1 pcs) - ADM15 (1 pcs) - ADM16 (1 pcs)
-	Declaration of CE conformity - User manual

Installation Example

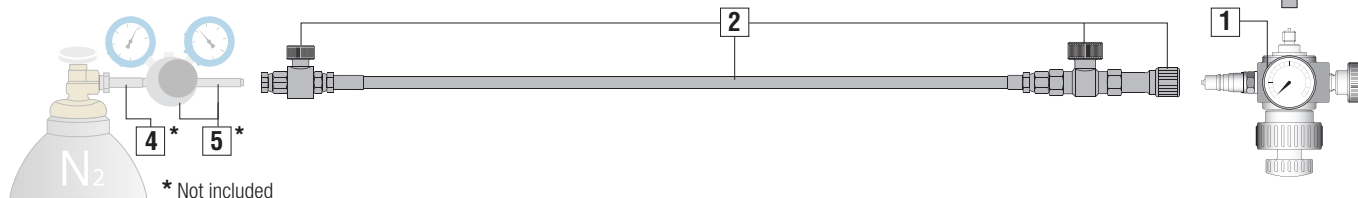

4*	Attacco per bombola - Connection for bottle - Ansatz für die Flasche - Décapage pour bombonne - Conexión para bombona - Ataque a Bottle p.324
5*	Riduttore di pressione - Pressure reducer - Druckminderer - Réducteur de pression - Reductor de presión - Redutor de pressão p.325

code 39DMCILA



- IT** Manometro 0 ÷ 315 bar - 2 manopole - valvola di riduzione/scarico pressione - adattatore fisso G1/8" - attacco rapido maschio Cejn.
- EN** 0 ÷ 315 bar gauge - 2 hand knobs- pressure limitation/discharging valve - G1/8" built in adapter - quickfit male Cejn.
- DE** Manometer 0 ÷ 315 bar - 2 Drehknopfs - Entlüftungsventil - fester Adapter G1/8" - Schnellverschlusskupplung Stecker Cejn.
- FR** Manomètre 0 ÷ 315 bar - 2 poignées - soupape de réduction/déchargement pression - Adaptateur fixe G1/8" - enclenchement instantané mâle Cejn.
- ES** Manómetro 0 ÷ 315 bar - 2 manillas - válvula de reducción/descarga de presión - adaptador fijo G1/8" - enchufe rápido macho Cejn.
- PT** Manómetro 0 ÷ 315 bar/psi - 2 manoplas - válvula de redução/descarga pressão - adaptador fixo G1/8" - engate rápido macho Cejn.

code	ith Mt hose
39DMCPVA	3 mt
39DMCPVA-5M ■	5 mt



- IT** mt di tubo - attacco rapido femmina Cejn - valvola ON/OFF - valvola di scarico tubo - 1 innesto rapido supplementare (cod. 39IR01A).
- EN** Mt high pressure hose- quickfit female Cejn- shut-off valve- hose release valve -additional quick coupling (cod. 39IR01A).
- DE** Meter Schlauch- Schnellverschlusskupplung Muffe Cejn- Sperrventil- Rohr Ablassventil- 1 zusätzliche Schnellverschluss Kupplung (im. 39IR01A).
- FR** m de tuyau – enclenchement instantané femelle Cejn – soupape ON/OFF – soupape de déchargement tuyau - 1 enclenchement instantané supplémentaire (cod. 39IR01A).
- ES** mt de tubo - enchufe rápido hembra Cejn - válvula ON/OFF - válvula de descarga tubo - 1 enchufe rápido suplementario (cod. 39IR01A).
- PT** mt de tubo – engate rápido fêmea Cejn - válvula ON/OFF - válvula de descarga tubo - 1 engate rápido suplementar (cod. 39IR01A).

code 39IR01A



ISO 72 - C - 2 - 2 - RP

- IT** Innesto rapido femmina per dispositivo 39DMCPVA (USARE SOLO CON PANNELLI CPVB - CPVD).
- EN** Quickfit female coupling for device 39DMCPVA (SUITABLE ONLY FOR CPVB - CPVD PANELS).
- DE** Schnellverschlusskupplung Muffe für Ausstattung 39DMCPVA (NUR FÜR CPVB - CPVD KONTROLLARMATUR).
- FR** Enclenchement instantané femelle pour dispositif 39DMCPVA (N'UTILISER QU'AVEC PANNEAUX CPVB - CPVD).
- ES** Enchufe rápido hembra para dispositivo 39DMCPVA (USO SOLAMENTE CON PANELES CPVB - CPVD).
- PT** Engate rápido fêmea para dispositivo 39DMCPVA (USE UNICAMENTE COM PAINÉIS CPVB - CPVD).

code 39IRFA

⚠ Only for 39DMCPV



Cejn 358

- IT** Innesto rapido femmina per dispositivo 39DMCPV (NON USARE CON PANNELLI CPVB - CPVD).
- EN** Quickfit female coupling for device 39DMCPV (NOT SUITABLE FOR CPVB - CPVD PANELS).
- DE** Schnellverschlusskupplung Muffe für Ausstattung 39DMCPV (NICHT MIT CPVB - CPVD ARMATUR VERWENDEN).
- FR** Enclenchement instantané femelle pour dispositif 39DMCPV (NE PAS UTILISER AVEC PANNEAUX CPVB - CPVD).
- ES** Enchufe rápido hembra para dispositivo 39DMCPV (NO USAR CON PANELES CPVB - CPVD).
- PT** Engate rápido fêmea para dispositivo 39DMCPV (NÃO USE COM PAINÉIS CPVB - CPVD).

code 39QDFV01 for 1/8G thread code 39QDFV02 for M6 thread code 39QDFV03 for M6 thread



- IT** Adattatore per caricamento diretto con innesto rapido maschio Cejn.
- EN** Cejin male quick fit adapter for direct charging.
- DE** Adapter für direkt Ladung mit Schnellverschlusskupplung Stecker Cejin.
- FR** Adaptateur direct pour le chargement avec enclenchement instantané mâle Cejin.
- ES** Adaptador para carga directa con enchufe rápido macho Cejin.
- PT** Adaptador direto para la carga con engate rápido macho Cejin.

⚠ tab below.

Code	39QDFV01	39QDFV03	39QDFV02	39QDFV03	39QDFV02	39QDFV02	39QDFV02	39QDFV03	39QDFV01
Modello Model Modell Model Modelo Modelo	ML1800 - 12000 (rev A)	HR300 Cu 5 - 16 HR500 Cu 5 - 16 HR700 Cu 10 - 16 HRF700 Cu 10 - 16 ML500 ML1000 LI400 Cu 13	NE16, NE24 (rev A) HR1000 - 4200 HRF1000 LI900 - 2000	SC150, SC250 SCF250, H300 H500, HF500 HR500 Cu 25 - 125 HR700 Cu 19 - 125 HRF500 Cu 25 - 125 HRF700 Cu 19 - 125 LI400 Cu 25 - 100	K40 ML300	HR200 MCS19 MCS19 - TBM MCS19 - TBI MCS19 - TEM MCS25	NE16 - NE24 (revB) NG16 - NG24 M50 - M70 M90 - MS90 M90 TBM - TBI - TEM M200 - MS200 M300 KE400 - 7500 RV170 - 2400 RS170 - 2400 SC150 - 250 (rev D) H 300 - 500 (rev C) ML300 (rev B+C+D) MP150	ML500-1000 (rev B+C+D) MP300 - 3000 MQ700	SC500 - 10000, SCF500 - 750 H700 - 18500 HF700 - 1000 HR6600 - 11800 LI3200 LS1500 - 9500 KE12000 - 18500 S500 - S3000 RV4200 - RV20000 RS4200 - RS9500 RF750 - RF2400 RG750 - RG6600 RT350 - RT9500 ML1800 - ML12000 (rev B+C+D)
A	G1/8"	M6	M6	M6	M6	M6	M6	M6	G 1/8"
Code	ADM01	ADM02	ADM03	ADM04	ADM05	ADM06	ADM08	ADM09	Direttamente con 39DMCILA (senza adattatore) Directly with 39DMCILA (without adapter) Direkt mit 39DMCILA (ohne Adapter) Directement avec 39DMCILA (sans adaptateur) Directamente con 39DMCILA (sin adaptador) Directamente com 39DMCILA (sem adaptador)

code ADM...

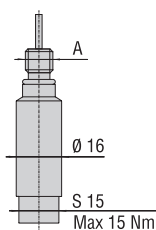

- IT** Adattatore per dispositivo 39DMCILA.
- EN** Adapter for 39DMCILA device.
- DE** Adapter für 39DMCILA Vorrichtung.
- FR** Adaptateur pour dispositif 39DMCILA.
- ES** Adaptador para dispositivo 39DMCILA.
- PT** Adaptador para dispositivo 39DMCILA.

⚠ tab above.

ACCESSORIES



code 39DDS-...

IT Dispositivo di scaricamento.

DE Ablassvorrichtung.

ES Dispositivo de descarga.

EN Discharging device.

FR Dispositif de déchargement.

PT Dispositivo de descarga.

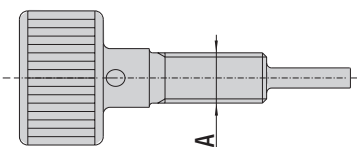

Code	39DDS-M6/1	39DDS-M6/2	39DDS-M6/3	39DDS-1/8G1	39DDS-1/8G	
A	M6	M6	M6	G 1/8"	G 1/8"	
Model	MCS K ML (rev. A) HR LI	NE (rev. A) SC (rev. B) H (rev. A) HR LI	NE (rev. B) NG M MS KE	ML (rev. B + C) HV RS SC (rev. D) H (rev. C)	K ML (rev. A)	SC H HR LI LS KE ML (rev. B) S RV RS RF RT RG



code 39DDS01A

IT Dispositivo di scaricamento.

DE Ablassvorrichtung.

ES Dispositivo de descarga.

EN Discharging device.

FR Dispositif de déchargement.

PT Dispositivo de descarga.

A	M6		
Model	NE (rev. B) NG M MS	KE ML (rev. B-C-D) MP MQ	RV RS SC (rev. D-E) H (rev. C-D)



A	G 1/8"		
Model	SC H HR LI	LS KE ML (rev. B) S	RV RS RF RT RG

code 58UT029A

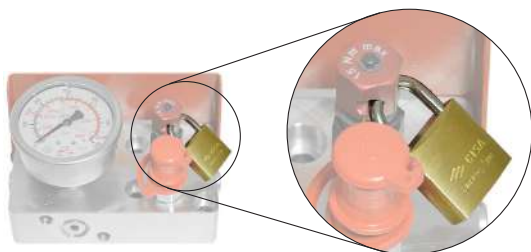

IT Lucchetto blocca valvola di scarico.

EN Padlock for discharge valve.

DE Vorhängeschloss für das Ablassventil.

FR Verrou pour soupape de décharge.

ES Candado de bloqueo de la válvula de descarga.

PT Cadeado para tramcar a valvula de descarregamento.

HOW TO USE IT

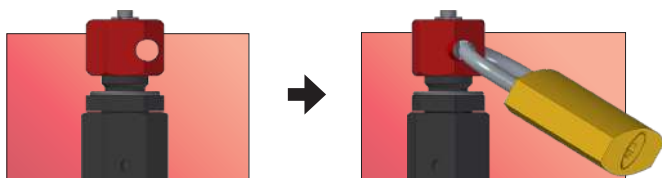

WHY TO USE IT

IT Per impedire caricamenti **NON autorizzati** durante la manutenzione.

EN To prevent **UNauthorized** charging during maintenance.

DE Um **unbefugtes** Befüllen zu verhindern bei der Wartung.

FR Pour empêcher le chargement **NON autorisé** pendant l'entretien.

ES Para impedir cargas **NO autorizadas** durante el mantenimiento.

PT Para impedir o carregamento **SEM autorização** durante a manutenção.

BENEFITS

IT Manutenzioni più sicure e con meno incidenti.

EN Safer maintenance and less accidents.

DE Mehr Sicherheit bei der Wartung und weniger Unfälle.

FR Un entretien plus sûr et moins d'accidents.

ES Mantenimientos más seguros y con menos accidentes.

PT Manutenção mais segura e com menos acidentes.

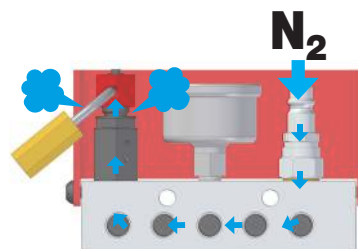

code 39SP01B

- IT** Sensore di pressione con display digitale. Collegando direttamente il sensore di pressione al controllo pressa è possibile impostare un range di lavoro desiderato al di fuori del quale il dispositivo invierà un segnale di allarme.
- EN** Pressure sensor with digital display. By connecting the pressure sensor directly to the press control, it is possible to set a desired working range outside which the unit sends an alarm signal.
- DE** Drucksensor mit Digitalanzeige. Wenn man den Drucksensor direkt an die Pressensteuerung anschließt, ist es möglich einen gewünschten Arbeitsbereich einzustellen, außerhalb dessen das Gerät ein Alarmsignal sendet.
- FR** Capteur de pression avec affichage numérique. En connectant le capteur de pression directement au système de contrôle de la presse, il est possible de définir une plage de fonctionnement souhaitée en dehors de laquelle l'unité envoie un signal d'alarme.
- ES** Sensor de presión con pantalla digital. Conectando directamente el sensor de presión al control de la prensa, es posible establecer un rango de trabajo deseado fuera del cual el dispositivo enviará una señal de alarma.
- PT** Sensor de pressão com display digital. Conectando o painel ao comando da prensa, é possível determinar uma faixa de trabalho, que qualquer alteração desta faixa, o painel emitira um alarme.

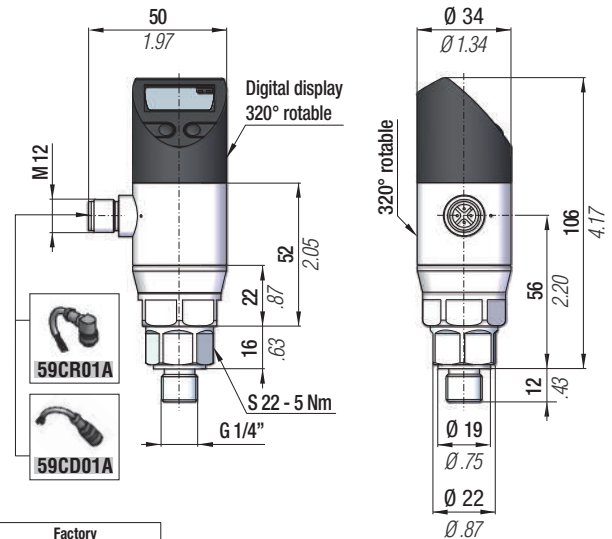

Technical data	
Electrical connector type	M12x1 - Male (4-pin), A-coded
Pressure connection	G 1/4" DIN 3852
Nominal pressure	0 - 600 bar
Burst pressure	1570 bar
Operating voltage U _o	18...36 V DC
Output current max.	150 mA
Current draw max	50 mA
Switching frequency f	170 Hz
Temperature range	- 25°C... + 85°C
Degree of protection as per IEC 60529	IP67 when connected

Electrical connections	Pin number	Wire color	Factory setting
Supply +	1	Brown	-
Supply -	3	Blue	-
Out 1	4	Black	PNP Switching output / IO-link
Out 2	2	White	PNP Switching output

Electrical connections	Programmable settings
Out 1	PNP-NPN Switching output / IO-Link
Out 2	PNP-NPN Switching output / 4...20mA - 0-10V analog output

Always depressurize and disconnect sensors from the power supply before establishing an electrical connection.

- IT** Sistema digitale alimentato a batteria per il controllo della pressione di cilindri ad azoto autonomi o di impianti collegati. Il sistema visualizza la pressione quando viene premuto il tasto e indica se accettabile attraverso i led rosso/verde (valore di soglia impostabile). Display in bar, psi o MPa.
- EN** Battery-powered digital system for pressure control of self-contained nitrogen cylinders or linked systems. The system displays the pressure when the key is pressed and indicates if it is acceptable through the red/green LEDs (settable threshold value). Display in bar, psi or MPa.
- DE** Batteriebetriebenes digitales System zur Druckregelung von geschlossenen Stickstoffflaschen oder angeschlossenen Systemen. Das System zeigt den Druck beim Drücken der Taste an und zeigt über die roten/grünen LEDs an, ob dieser akzeptabel ist (einstellbarer Schwellenwert). Anzeige in bar, psi oder MPa.
- FR** Système numérique alimenté par batterie pour le contrôle de la pression des bouteilles d'azote autonomes ou des systèmes connectés. Le système affiche la pression à l'appui sur la touche et indique si elle est acceptable par les leds rouges/vertes (valeur seuil paramétrable). Affichage en bar, psi ou MPa.
- ES** Sistema digital alimentado por batería para el control de presión de cilindros de nitrógeno autónomos o sistemas conectados. El sistema muestra la presión cuando se presiona la tecla e indica si es aceptable a través de los LED rojo/verde (valor umbral configurable). Visualización en bar, psi o MPa.
- PT** Sistema digital alimentado por bateria para controle de pressão de cilindros de nitrogênio independentes ou sistemas conectados. O sistema exibe a pressão quando a tecla é pressionada e indica se ela é aceitável através dos LEDs vermelho/verde (valor limite configurável). Exibição em bar, psi ou MPa.

EYE PRESSURE SENSOR



Technical data	
Measuring range (relative):	0 ÷ 600 bar / 8700 psi / 60 MPa
Visualization:	3 digit display + 2 led
Measurement unit:	bar, psix10, MPa
Resolution:	1 bar, 10 psi, 1 MPa
Accuracy:	±2,0% f.s. or ±1 digit, whichever is greater
Working temperature:	0 ÷ 80°C / 176°F
Compatible fluids:	Nitrogen
Battery:	Maxell CR2032-3V, 220mAh
Material:	Stainless steel/Aluminum alloy
Connection:	G 1/8
Alarms:	Min. pressure (adjustable), Pressure over 450 bar / 6530 psi / 45 MPa, Sensor malfunction, Low battery
Battery lifetime:	> 2000 readings
Protection Grade:	IP65 when connected
39SPB02A Suitable for:	CP01A, CP03A, CP07A, CP10A, CP12A, MCPC, CP19A, AUMCP
39SPB01A Suitable for:	Gas springs with G1/8" Charging hole and CP23A

code 39SPB01A

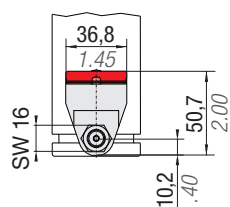
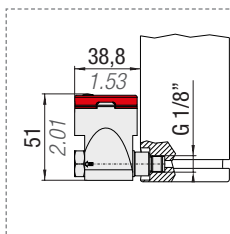

code 39SPB02A

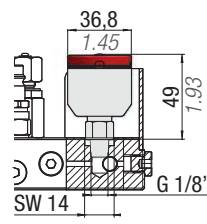

ACCESSORIES



IT Tappo di sicurezza sovrappressione CE.

EN Overpressure safety plug CE.

DE Überdruck Sicherheitsstecker CE.

FR Bouchon de sécurité surpression CE.

ES Tapón de seguridad por sobrepresión CE.

PT Bujão de segurança sobrepresão CE.

code: 39TS300

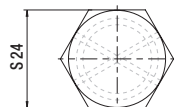
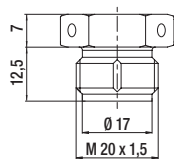

Burst pressure
@20°C 300bar / 4350 psi

code: 39TS360

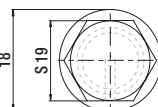
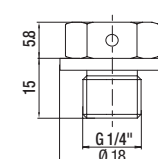

Burst pressure
@20°C 360bar / 5220 psi

code: 39TS460

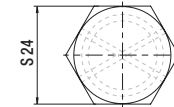
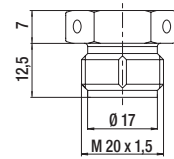

Burst pressure
@20°C 460bar / 6670 psi

code 58UT037A

IT Utensile per avvitare e svitare i cilindri SCF 250 e HF 500.

EN Tool to screw and unscrew gas springs SCF 250 and HF 500.

DE Schlüssel zum An- und Abschrauben von Gasdruckfedern SCF 250 und HF 500.

FR Outil pour visser et dévisser les ressorts à gaz SCF 250 et HF 500.

ES Herramienta para atornillar y desenroscar resortes de gas SCF 250 y HF 500.

PT Ferramenta para parafusar e desparafusar molas a gás SCF 250 e HF 500.

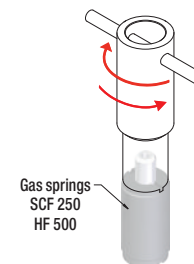
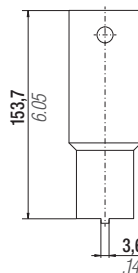
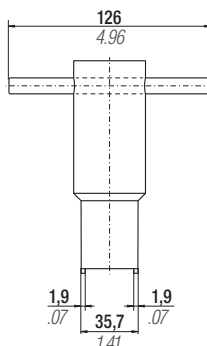

IT Chiave dinamometrica con accessori.

EN Torque wrench with accessories.

DE Drehmomentschlüssel mit Zubehör.

FR Clé dynamométrique avec ses accessoires.

ES Llave dinamométrica con accesorios.

PT Chave dinamométrica com acessórios.

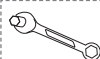

Torque force

code	Nm
58UT025A	4 - 40



code
58UT013A



code	size	
	mm	inch
58UT009A	3	0.12
58UT010A	4	0.16
58UT011A	6	0.24
58UT012A	8	0.31



code	size	
	mm	inch
58UT014A	10	0.39
58UT015A	12	0.47
58UT016A	14	0.55
58UT017A	15	0.59
58UT018A	17	0.67
58UT019A	18	0.71
58UT020A	19	0.75
58UT065A	14,3	9/16

ORDERING EXAMPLE

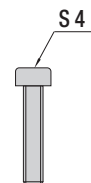

58UT025A
+
58UT013A
+
58UT010A

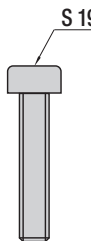

58UT025A
+
58UT020A

WARNING PLATE

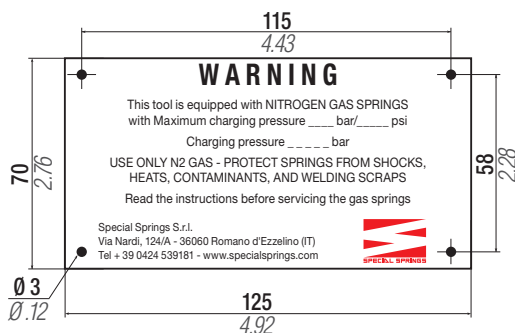

IT Targhetta

EN Advice plate

DE Schilder

FR Plaquettes

ES Placas

PT Etiquetas

Codice 39 TAR-I

Code 39 TAR-GB

Bestellnummer 39 TAR-D

Référence 39 TAR-F

Codigo 39 TAR-E

Codigo 39 TAR-P

All dimensions in mm/inch



code	Service tools	Service accessories
CMCA	✓	✓

- IT** Set completo per manutenzione cilindri. **FR** Kit d'entretien complet pour ressorts à gaz.
- EN** Service tools and Accessories for gas spring maintenance. **ES** Kit de mantenimiento completo para resortes de gas.
- DE** Komplettes Wartungsset für Gasdruckfedern. **PT** Kit de manutenção completo para cilindros.



code	Service tools	Service accessories
CMCTA	✓	✗

- IT** Solo set utensili per manutenzione cilindri. **FR** Set d'outils pour l'entretien de ressorts à gaz.
- EN** Service tools for gas spring maintenance. **ES** Set de herramientas para mantenimiento de resortes de gas.
- DE** Nur Werkzeugsset zur Wartung von Gasdruckfedern. **PT** Conjunto de ferramentas para manutenção dos cilindros.



code	Service tools	Service accessories (specific family of gas springs)
CMC - ...	✗	✓

- IT** Set accessori per determinata famiglia di cilindri (es. CMC-SC 10000-A). **FR** Jeu d'accessoires pour une famille donnée de cylindres (ex.: CMC-SC 10000-A).
- EN** Service accessories for maintenance of a specific gas spring model (ex. CMC-SC 10000-A). **ES** Set de accesorios para una determinada familia de cilindros (p.ej. CMC-SC 10000-A).
- DE** Zubehörset für bestimmte Zylindertypen (z. B. CMC-SC 10000-A). **PT** Acessórios de conjunto para determinada família de cilindros (ex. CMC-SC 10000-A).

code 58CD01



- IT** Cacciavite dinamometrico per valvola unidirezionale.
- EN** Torque screwdriver for one-way valve.
- DE** Drehmomentschrauber für Rückschlagventil.
- FR** Tournevis dynamométrique pour valve anti-retour.
- ES** Destornillador dinámico para válvula anti-retorno.
- PT** Chave torquimétrica para válvula de retenção.

code 39PM02A



- IT** Pressa manuale per assemblaggio stelo, boccia e anello di ritegno a C.
- EN** Table manual press for assembly of rod, bushing and retaining C-ring.
- DE** Manuelle Presse zur Montage von Kolbenstange, Buchse und Sprengring.
- FR** Presse manuelle pour l'assemblage de la tige, douille et bague d'étanchéité en C.
- ES** Prensa manual para ensamblaje vástago, casquillo y anillo de retención a C.
- PT** Prensa manual para ensambladura haste, bucha e anel de retenção a C.

code 59VU02A



- IT** Valvola unidirezionale (esclusi M50-TBI/TBM1/TBM2/TEM, M70, M90-TBM/TEM/TBI, MS90, M/MS200, RV/RS170, RV/RS320).
- EN** One-way valve (excluding M50-TBI/TBM1/TBM2/TEM, M70, M90-TBM/TEM/TBI, MS90, M/MS200, RV/RS170, RV/RS320).
- DE** Rückschlagventil (außer M50-TBI/TBM1/TBM2/TEM, M70, M90-TBM/TEM/TBI, MS90, M/MS200, RV/RS170, RV/RS320).
- FR** Valve anti-retour (à l'exclusion de M50-TBI/TBM1/TBM2/TEM, M70, M90-TBM/TEM/TBI, MS90, M/MS200, RV/RS170, RV/RS320).
- ES** Válvula anti-retorno (excepto M50-TBI/TBM1/TBM2/TEM, M70, M90-TBM/TEM/TBI, MS90, M/MS200, RV/RS170, RV/RS320).
- PT** Válvula de retenção (excluindo M50-TBI/TBM1/TBM2/TEM, M70, M90-TBM/TEM/TBI, MS90, M/MS200, RV/RS170, RV/RS320).

Product Suggestion



- IT** Spray rivelatore di fughe.
- EN** Gas detector.
- DE** Gasdetektor Spray.
- FR** Spray détecteur de fuites de gaz.
- ES** Spray detector de escapes de gas.
- PT** Spray revelador de fugas de gás.

Potential supplier
www.tecnogas.net

ACCESSORIES



- IT** Attacco per bombola.
- EN** Connection for bottle.
- DE** Ansatz für die Flasche.
- FR** Décapage pour bombonne.
- ES** Adaptador para bombona
- PT** Ataque a Bottle.

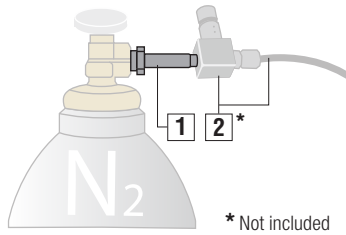

* Not included

Installation Example

<p>1 Attacco per bombola Connection for bottle Ansatz für die Flasche Décapage pour bombonne Adaptador para bombona Ataque a Bottle</p>	<p>2* Tubo collegamento bombola con valvola di scarico Connecting hose from the bottle to the valve discharging Verbindungsschlauch der Flasche mit Auslassventil Tube pour la connexion bombonne avec valve de décharge Tubo de conexión a bombona con válvula de descarga Tubo de ligação Frasco com a válvula de descarga</p>
--------------------------------------------------------------------------------------------------------------------------------------------------------------------	-------------------------------------------------------------------------------------------------------------------------------------------------------------------------------------------------------------------------------------------------------------------------------------------------------------------------------------------------------------

code	X	Box content	Country
47TB	W 21,7x1/14" - Male - ISO 228	O-ring 1/4" BSP	IT - Italy PT - Portugal
47TB01	-	O-ring 1/4" BSP	CN - China KR - South Korea
47TB02	W 22,5 - 14 t.p.i JIS B 8246 - Male	O-ring 1/4" BSP	JP - Japan ID - Indonesia
47TB03	W 24,32x1/14" - DIN 477 - 1 Female (for bottles up to 200 bar / 2900 psi)	O-ring 1/4" BSP	DE - Germany
47TB04	d 21,7x1,814 - NF E 29 - 650 - Female	O-ring 1/4" BSP	FR - France
47TB05	G 5/8" - ISO 228 - Male	O-ring 1/4" BSP	IN - India
47TB06	G 3/4" - ISO 228 - Female	O-ring 1/4" BSP	RU - Russia
47TB07	0.960 - 14 NGO - RH - Male - CGA NO. 580 (for bottles up to 206 bar / 3000 psi)	O-ring 1/4" BSP	US - United States
47TB08	1.040 - 14 NGO - RH - Male - CGA NO. 680 (for bottles from 206 bar / 3000 psi to 324 bar / 4700 psi)	O-ring 1/4" BSP	US - United States
47TB09	W 21,7x1/14 - Female	O-ring 1/4" BSP	ES - Spain PT - Portugal
47TB10	W 24,32x1/14 - DIN 477 - 1 - Female	O-ring 1/4" BSP	KR - South Korea
47TB11	W 30x2 - DIN 477 - 5 - Female (for bottles from 200 bar / 2900 psi to 300 bar / 4351 psi)	O-ring 1/4" BSP	DE - Germany
47TB12	G 3/4A - RH IS 3224 - Female	O-ring 1/4" BSP	IN - India
47TB13	W 22 - 14 t.p.i JIS B 8246 - Male	O-ring 1/4" BSP	JP - Japan
47TB15	G 5/8" - ISO 228 - Male	O-ring 1/4" BSP	UK - United Kingdom

code	Box content	Country
Phasing out	New	1 + 2
39RP (max. inlet pressure 200 bar / 2900 psi)	39RHP (max. inlet pressure 300 bar / 4350 psi)	IT - Italy PT - Portugal
39RP01 (max. inlet pressure 200 bar / 2900 psi)	39RHP01 (max. inlet pressure 300 bar / 4350 psi)	CN - China KR - South Korea
39RP02 (max. inlet pressure 200 bar / 2900 psi)	39RHP02 (max. inlet pressure 300 bar / 4350 psi)	JP - Japan ID - Indonesia
39RP03 (max. inlet pressure 200 bar / 2900 psi)	39RHP03 (max. inlet pressure 200 bar / 2900 psi) (for bottles up to 200 bar / 2900 psi)	DE - Germany
39RP04 (max. inlet pressure 200 bar / 2900 psi)	39RHP04 (max. inlet pressure 300 bar / 4350 psi)	FR - France
39RP05 (max. inlet pressure 200 bar / 2900 psi)	39RHP05 (max. inlet pressure 300 bar / 4350 psi)	IN - India
39RP06 (max. inlet pressure 200 bar / 2900 psi)	39RHP06 (max. inlet pressure 300 bar / 4350 psi)	RU - Russia
39RP07 (max. inlet pressure 200 bar / 2900 psi)	39RHP07 (max. inlet pressure 300 bar / 4350 psi) (for bottles up to 206 bar / 3000 psi)	US - United States
39RP08 (max. inlet pressure 200 bar / 2900 psi)	39RHP08 (max. inlet pressure 300 bar / 4350 psi) (for bottles from 206 bar / 3000 psi to 324 bar / 4700 psi)	US - United States
39RP09 (max. inlet pressure 200 bar / 2900 psi)	39RHP09 (max. inlet pressure 300 bar / 4350 psi)	ES - Spain PT - Portugal
39RP10 (max. inlet pressure 200 bar / 2900 psi)	39RHP10 (max. inlet pressure 300 bar / 4350 psi)	KR - South Korea
39RP11 (max. inlet pressure 200 bar / 2900 psi)	39RHP11 (max. inlet pressure 300 bar / 4350 psi) (for bottles from 200 bar / 2900 psi to 300 bar / 4351 psi)	DE - Germany
39RP12 (max. inlet pressure 200 bar / 2900 psi)	39RHP12 (max. inlet pressure 300 bar / 4350 psi)	IN - India
39RP13 (max. inlet pressure 200 bar / 2900 psi)	39RHP13 (max. inlet pressure 300 bar / 4350 psi)	JP - Japan
-	39RHP15 (max. inlet pressure 300 bar / 4350 psi)	UK - United Kingdom

IT Riduttore di pressione completo di attacco bombola per controllare e ridurre la pressione.

EN Pressure reducer complete with bottle connection to control and reduce the pressure.

DE Druckminderer komplett mit Flaschenanschluss, um den Druck zu kontrollieren und verringern.

FR Réducteur de pression complet avec jonction de bouteille pour contrôler et réduire la pression.

ES Reductor de presión completo con adaptador a bombona para controlar y reducir la presión

PT Redutor de pressão completo com engate para controlar e reduzir a pressão

Example code: 39RHP



Installation Example

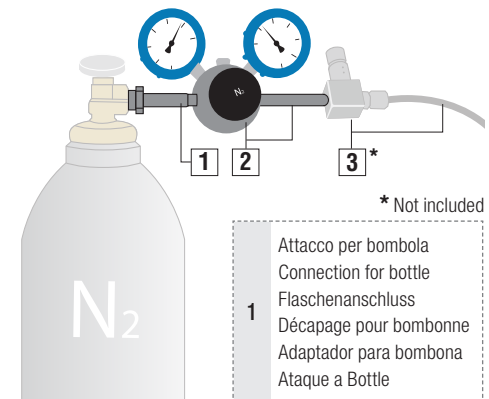

2 Riduttore di pressione max. 300 bar / 4350 psi
Pressure reducer max. 300 bar / 4350 psi
Druckminderer max. 300 bar / 4350 psi
Réducteur de pression max. 300 bar / 4350 psi
Reductor de presión max. 300 bar / 4350 psi
Redutor de pressão max. 300 bar / 4350 psi

3* Tubo collegamento bombola con valvola di scarico
Connecting hose from the bottle to the valve discharging
Flaschen Verbindungsschlauch mit Auslassventil
Tube pour la connexion bombonne avec valve de décharge
Tubo de conexión a bombona con válvula de descarga
Tubo de ligação Frasco com a válvula de descarga

ACCESSORIES



* Not included

code	Box content 1 + (2 + 3) + 4	Power supply	Country	Kg	
39NCU01B	Booster + 39RHP	220 ÷ 240 VAC 50 ÷ 60 Hz	Italy - Portugal	105 kg	231 lbs
39NCU10B	Booster + 39RHP01	220 ÷ 240 VAC 50 ÷ 60 Hz	China - Korea	105 kg	231 lbs
39NCU11B	Booster + 39RHP02	220 ÷ 240 VAC 50 ÷ 60 Hz	Indonesia	105 kg	231 lbs
39NCU12B	Booster + 39RHP03	220 ÷ 240 VAC 50 ÷ 60 Hz	Germany	105 kg	231 lbs
39NCU13B	Booster + 39RHP04	220 ÷ 240 VAC 50 ÷ 60 Hz	France	105 kg	231 lbs
39NCU14B	Booster + 39RHP05	220 ÷ 240 VAC 50 ÷ 60 Hz	India	105 kg	231 lbs
39NCU15B	Booster + 39RHP06	220 ÷ 240 VAC 50 ÷ 60 Hz	Russia	105 kg	231 lbs
39NCU22B	Booster + 39RHP07	120 VAC 50 ÷ 60 Hz	USA	116 kg	255 lbs
39NCU23B	Booster + 39RHP08	120 VAC 50 ÷ 60 Hz	USA	116 kg	255 lbs
39NCU29B	Booster + 39RHP09	220 ÷ 240 VAC 50 ÷ 60 Hz	Spain	105 kg	231 lbs
39NCU31B	Booster + 39RHP10	220 ÷ 240 VAC 50 ÷ 60 Hz	Korea	105 kg	231 lbs
39NCU32B	Booster + 39RHP11	220 ÷ 240 VAC 50 ÷ 60 Hz	Germany	105 kg	231 lbs
39NCU33B	Booster + 39RHP12	220 ÷ 240 VAC 50 ÷ 60 Hz	India	105 kg	231 lbs
39NCU34B	Booster + 39RHP13	100 VAC 50 ÷ 60 Hz	Japan	120 kg	265 lbs
39NCU40B	Booster + 39RHP14	220 ÷ 240 VAC 50 ÷ 60 Hz	Portugal	105 kg	231 lbs
39NCU41B	Booster + 39RHP02	100 VAC 50 ÷ 60 Hz	Japan	120 kg	265 lbs
39NCU42B	Booster + 39RHP15	220 ÷ 240 VAC 50 ÷ 60 Hz	United Kingdom	105 kg	231 lbs

1	Booster carrellato per il caricamento di grandi volumi di azoto, con azionamento elettro-idraulico per la massima velocità Wheeled Booster for the filling of large volumes of nitrogen, with electro-hydraulic start-up for the maximum speed Ein fahrbarer Booster für die Ladung großer Mengen von Stickstoff, mit elektrohydraulischem Antrieb für Maximalgeschwindigkeit. Booster à chariot, pour la charge de grands volumes d'azote, avec actionnement électro-hydraulique pour la vitesse maximum Booster con ruedas para la carga de grandes volúmenes de nitrógeno con accionamiento electro-hidráulico para máxima rapidez. Booster rodado para o carregamento de grandes volumes de nitrogênio com acionamento eletro-hidráulico para a velocidade máxima	2	Attacco per bombola Connection for bottle Ansatz für die Flasche Décapage pour bombonne Adaptador para bombona Ataque a Bottle	Direct to N2 bottle p. 324 	
3	Riduttore di pressione Pressure reducer Druckminderer Réducteur de pression Reductor de presión Redutor de pressão	4	Tubo collegamento bombola con valvola di scarico Connecting hose from the bottle to the valve discharging Verbindung Schlauche des Flasche mit Auslassventil Tube pour la connexion bombonne avec valve de décharge Tubo de conexión a bombona con válvula de descarga Tubo de ligação Frasco com a válvula de descarga	5*	Dispositivo di caricamento DMA Charging device DMA Ladung Vorrichtung DMA Dispositif de charge DMA Dispositivo de carga DMA Dispositivo de carregamento de DMA

IT Caratteristiche - vantaggi

- Massima sicurezza, minimi tempi di caricamento
 - Arresto automatico alla pressione impostata
 - Segnale luminoso di fine ciclo
 - Valvola di sicurezza per sovrappressione
 - Pompa elettrica
 - Pressione di uscita regolabile
 - Telaio carrellato con alloggiamento bombola N2
 - Utilizzare con set di caricamento DMA (opzionale)
- La fornitura comprende:** Unità booster, 3 mt di tubo per collegamento a bombola o riduttore di pressione + attacco per bombola.

FR Caractéristiques - avantages

- Sécurité maximum, temps de chargement minimum
 - Arrêt automatique à la pression établie
 - Signal lumineux de fin de cycle
 - Valve de sécurité pour la surpression
 - Pompe électrique
 - Pression de sortie réglable
 - Châssis à chariot avec logement de bonbonne N2
 - À utiliser avec le set de chargement DMA (en option)
- La fourniture inclut:** Unité booster, 3 mt de tube pour la connexion à la bombonne ou au réducteur de pression + Décapage bombonne.

EN Features - advantages

- Maximum safety, low charging time
 - Automatic stop when the set pressure is reached
 - Light indicator of cycle end
 - Safety valve for overpressure
 - Electric pump
 - Adjustable output pressure
 - Wheeled cart with N2 bottle housing
 - To be used with charging set DMA (optional)
- The supply includes:** Booster unit, 3 mt hose for connecting the bottle or pressure reducer + bottle connection.

ES Características - Ventajas

- Máxima seguridad, tiempo mínimo de carga
 - Parada automática en la presión elegida
 - Señal luminosa de final de ciclo
 - Válvula de seguridad para sobrepresión
 - Bomba eléctrica
 - Presión de salida regulable
 - Chasis sobre ruedas y alojamiento para botella de N2
 - Utilizar combinado con set de carga DMA (opcional)
- El suministro incluye:** Unidad Booster, tubo de 3 mt para conexión a la bombona o al reductor de presión + adaptador para Bombona.

DE Eigenheiten - Vorteile

- Maximale Sicherheit, minimale Befüllzeiten
 - Automatisches Anhalten beim Erreichen des Drucks
 - Leuchtsignal bei Zyklusende
 - Überdruck-Sicherheitsventil
 - Elektrische Pumpe
 - Einstellbarer Output-Druck
 - Fahrbares Gestell mit Ablagefach für N2-Gasflasche
 - Zum Einsatz mit der DMA Ladevorrichtung (optional)
- Die Lieferung beinhaltet:** Booster Gerät, 3 Meters Schlauch für den Anschluss zur Flasche oder zum Druckminderer + Ansatz für die Flasche.

PT Características - Benefícios

- Máxima segurança, tempos de carregamento mais baixos
 - Paragem automática quando atingida a pressão especificada
 - Sinal luminoso de fim de ciclo
 - Válvula de segurança activa sobrepresão
 - Bomba eléctrica
 - Saída de pressão ajustável
 - Quadro rodado com alojamento para tank N2
 - Utilizado com o conjunto de carregamento DMA (opcional)
- O fornecimento inclui:** Unidade Booster, 3 mt tubo para ligação ao cilindro de azoto ou de reductor de pressão + Ataque a Bottle.

	Pmax	Pmin	Vm			
0,85 kW see power supply	210 bar 3045 psi	30 bar 435 psi	1300 NL / min *	0 - 45 °C 32 - 113 °F	600 x 560 x 680 mm 24 x 22 x 27 inch	See tab.

* Il rendimento volumetrico varia in funzione di PN₂ - The volumetric efficiency varies according to PN₂ - Der Liefergrad ändert sich in Abhängigkeit vom PN₂
Le rendement volumétrique varie en fonction de PN₂ - El rendimiento volumétrico varía en función de PN₂ - O rendimento volumétrico varia em função da PN₂



* Not included

To N2 bottle with pressure reducer
 p. 325

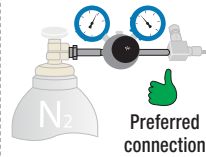

Direct to N2 bottle
 p. 324



code	Box content 1 + 2	Country
39NCU03A	AirBooster + 47TB	Italy - Portugal
39NCU04A	AirBooster + 47TB01	China - Korea
39NCU05A	AirBooster + 47TB02	Japan - Indonesia
39NCU06A	AirBooster + 47TB03	Germany
39NCU07A	AirBooster + 47TB04	France
39NCU08A	AirBooster + 47TB05	India
39NCU09A	AirBooster + 47TB06	Russia
39NCU26A	AirBooster + 47TB07	USA
39NCU27A	AirBooster + 47TB08	USA
39NCU28A	AirBooster + 47TB09	Spain
39NCU35A	AirBooster + 47TB10	Korea
39NCU36A	AirBooster + 47TB11	Germany
39NCU37A	AirBooster + 47TB12	India
39NCU38A	AirBooster + 47TB13	Japan
39NCU39A	AirBooster + 47TB14	Portugal
39NCU43A	AirBooster + 47TB15	UK

1	Booster portatile compatto per caricamento azoto con azionamento pneumatico Compact portable booster for the filling of nitrogen, with pneumatic start-up Ein kompakter und portabler Booster Booster compacte et portable pour la charge avec azote, avec actionnement pneumatique Booster compacto y portátil para la carga con nitrógeno con accionamiento neumático Booster compacto e portátil para carregar com nitrogênio com acionamento pneumático	2	Attacco per bombola Connection for bottle Ansatz für die Flasche Décapage pour bombonne Adaptador para bombona Ataque a Bottle	3*	Riduttore di pressione Pressure reducer Druckminderer Réducteur de pression Reductor de presión Redutor de pressão		
4	Tubo collegamento bombola con valvola di scarico Connecting hose from the bottle to the valve discharging Flaschen-Verbindungsschlauch mit Auslassventil Tube pour la connexion bombonne avec valve de décharge Tubo de conexión a bombona con válvula de descarga Tubo de ligação Frasco com a válvula de descarga	5	Ingresso aria Air inlet Luft Eingang Entrée de l'air Entrada de aire Entrada de ar	6*	Dispositivo di caricamento 39DMB Charging device 39DMB Lade-Vorrichtung 39DMB Dispositif de charge 39DMB Dispositivo de carga 39DMB Dispositivo de carregamento de 39DMB	7	Valvola sicurezza e ingresso aria Safety valve and air inlet Sicherheitsventil und Lufteingang Valve de sécurité et entrée de l'air Válvula de seguridad y entrada de aire Válvula de segurança e entrada de ar

IT Caratteristiche - Vantaggi

- Compatto, leggero e portabile
- Massimo utilizzo del volume bombola N2
- Installazione diretta su bombola N2
- Valvola di sicurezza output N2 max 220 bar

La fornitura comprende: Unità booster completa di valvola di sicurezza, supporto per bombola, 1 mt di tubo per collegamento a bombola o riduttore di pressione + attacco per bombola.

EN Features - Advantages

- Compact, light and portable
- Max use of the nitrogen bottle N2
- Direct installation on the N2 bottle
- Safety N2 output valve max 220 bar

The supply includes: Booster unit provided with safety valve, bottle support, 1 mt hose for connecting the bottle or pressure reducer + bottle connection.

DE Eigenschaften - Vorteile

- Kompakt, leicht und portabel
- Maximaler Nutzung der Stickstoffflasche N2
- Direkte Installation an Stickstoffflasche N2
- Sicherheitsventil output N2 , max. 220 bar.

Die Lieferung beinhaltet: Booster-Gerät versehen mit Sicherheitsventil, Träger für die Stickstoffflasche, 1 Meter Schlauch für den Anschluss zur Flasche oder zum Druckminderer + Ansatz für die Flasche.

FR Caractéristiques - Avantages

- Compacte, léger et portable
- Utilisation maximale de la bombonne d'azote N2
- Installation directe sur la bombonne d'azote N2
- Valve de sortie N2 sécurisé max 220 bar

La fourniture inclut: Unité booster équipé avec valve de sécurité, support pour bombonne, 1 mt de tube pour la connexion à la bombonne ou au réducteur de pression + Décapage bombonne.

ES Características - Ventajas

- Compacto, ligero y portátil
- Uso máximo de la bombona de nitrógeno N2
- Instalación directamente sobre la bombona de N2
- Válvula de seguridad, output N2 max 220 bar

El suministro incluye: Unidad Booster equipado con válvula de seguridad, soporte para la bombona de nitrógeno, tubo de 1 mt para la conexión a la bombona o al reductor de presión + Adaptador a Bombona.

PT Características - Benefícios

- Compacto, leve e portátil
- Máxima utilização do cilindro de nitrogênio N2
- Instalação directamente sobre o cilindro de N2
- Válvula de segurança, saída máxima de 220 bar N2

O fornecimento inclui: Unidade Booster equipado com válvula de segurança, o suporte para o cilindro de nitrogênio, 1 mt tubo para ligação ao cilindro de azoto ou de reductor de pressão + Ataque a Bottle.

AIR 1 - 10 bar 15 - 145 psi	220 bar 3190 psi	30 bar 435 psi	280 NL / min *	0 - 45 °C 32 - 113 °F	230 x 350 x 230 mm 9 x 13 x 9 inch	10,8 Kg 23.8 lbs

* Il rendimento volumetrico varia in funzione di Pair e PN2 - The volumetric efficiency varies according to Pair and PN2 - Der Volumen-Liefergrad ändert sich in Abhängigkeit vom Pair und PN2
 Le rendement volumétrique varie en fonction de Pair et PN2 - El rendimiento volumétrico varia en función de PN2 - O rendimento volumétrico varia em função da Pair e PN2

ACCESSORIES



IT Trolley completo di AirBooster e dispositivo 39DMB.

DE Trolley mit AirBooster und Füll- und Kontrollarmatur 39DMB.

ES Maleta completa con AirBooster y dispositivo 39DMB.

EN Trolley with AirBooster and charging device 39DMB.

FR Chariot avec AirBooster et kit de chargement 39DMB.

PT Maleta completa com Booster e Kit de carregamento 39DMB.



i AirBooster
p. 327

i 39DMB
p. 318

code	Box content	Country
39KNCU03A	39NCU03A + 39DMB	Italy - Portugal
39KNCU04A	39NCU04A + 39DMB	China - Korea
39KNCU05A	39NCU05A + 39DMB	Japan - Indonesia
39KNCU06A	39NCU06A + 39DMB	Germany
39KNCU07A	39NCU07A + 39DMB	France
39KNCU08A	39NCU08A + 39DMB	India
39KNCU09A	39NCU09A + 39DMB	Russia
39KNCU26A	39NCU26A + 39DMB	USA
39KNCU27A	39NCU27A + 39DMB	USA
39KNCU28A	39NCU28A + 39DMB	Spain
39KNCU35A	39NCU35A + 39DMB	Korea
39KNCU36A	39NCU36A + 39DMB	Germany
39KNCU37A	39NCU37A + 39DMB	India
39KNCU38A	39NCU38A + 39DMB	Japan
39KNCU39A	39NCU39A + 39DMB	Portugal
39KNCU40A	39NCU43A + 39DMB	UK

IT Caratteristiche

Trolley con struttura antiurto e valvola pressurizzata per lo spostamento aereo e la sicurezza dei dispositivi all'interno.

EN Features

Trolley with shock-resistant structure and pressure relief valve for transport in the aircraft and safe storage of the contents.

DE Eigenheiten

Trolley mit stoßfester Struktur und Überdruckventil für den Transport im Flugzeug und ein sicheres Verstauen des Inhalts.

FR Caractéristiques

Chariot avec structure résistante aux chocs et soupape de surpression pour le transport dans l'avion et le stockage sécurisé du contenu.

ES Características

Maleta con estructura a prueba de golpes y válvula presurizada para viajes aéreos y para la seguridad de los dispositivos en el interior.

PT Características

Maleta de ferramentas com estrutura reforçada e pressurizada para viagens aéreas garantindo a segurança dos equipamentos.

IT Stazione mobile per caricamento, controllo forza e manutenzione dei cilindri ad azoto.

EN Mobile service station for charging, force testing and maintenance of gas springs.

DE Mobile Servicestation zum Befüllen, zur Druckkontrolle und zur Wartung der Gasdruckfedern.

FR Station de service mobile pour le chargement, la mesure de force et la maintenance de ressorts à gaz.

ES Estación móvil para carga, control de fuerza y mantenimiento de cilindros de gas.

PT Estação de trabalho movel para carregamento, ajuste de força e manutenção dos cilindros.

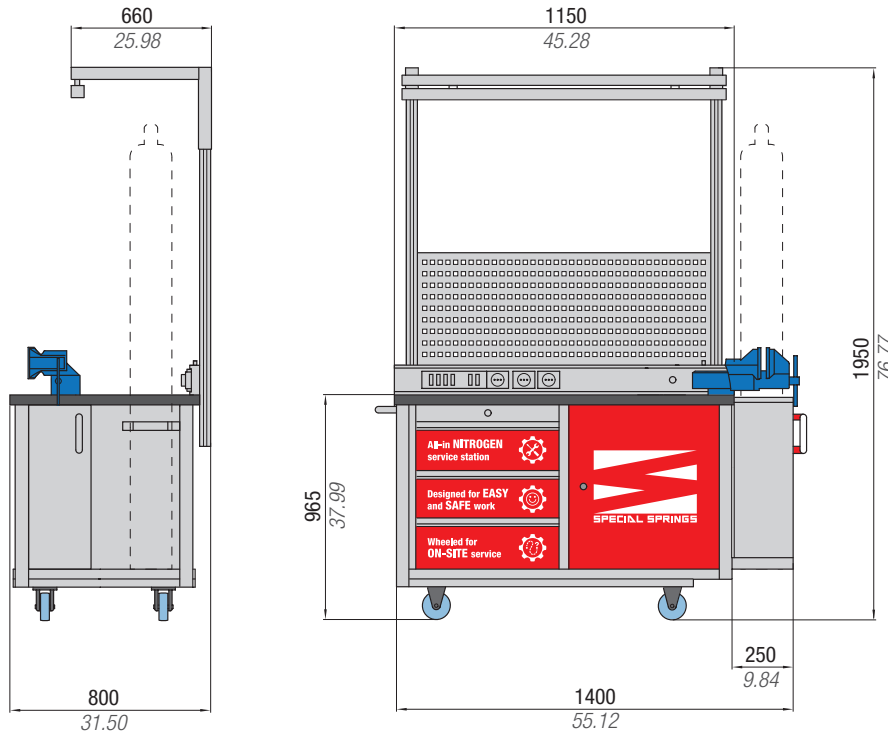

code	Country
58UT027A	Italy - Denmark Egypt - Russia Austria - Indonesia India - Greece Holland - Romania Finlandia Czech Republic Spain - France Slovenia - Portugal Turkey - Korea Germany
58UT031A	Japan - Usa
58UT032A	Belgium - France
58UT033A	United Kingdom
58UT034A	Brasil
58UT036A	China

 **225 kg / 496.04 lbs**

IT Vantaggi

- Unica postazione per strumenti e kit.
- Elevata mobilità.
- Maggiore sicurezza e comodità per ogni operazione.
- Predisposizione ancoraggio force tester.

FR Avantages

- Station tout-en-un pour tous outils et appareils.
- Grande mobilité.
- Plus de sécurité et de confort pour chaque opération.
- Préparé pour le montage du testeur de force.

IT Dati tecnici

- 3 cassetti (1 con vaschetta raccogli olio) + anta per riporre kit e tools.
- Piano di lavoro 1400 x 685 x 40 mm.
- Lampada a led con interruttore.
- Attacco aria compressa da 1/4".
- 3 prese elettriche.
- Connettore di alimentazione non incluso.
- Morsa parallela 130 mm.
- Protezione operatore da proiezione parti in fase di caricamento.

FR Données techniques

- 3 tiroirs (un avec bac de récupération d'huile) + compartiment fermé avec porte pour ranger kits et outils.
- Plan de travail 1400 x 685 x 40 mm.
- Lumière LED avec interrupteur.
- Alimentation en air comprimé 1/4".
- 3 prises de courant.
- La prise électrique n'est pas comprise.
- Étau parallèle 130 mm.
- Protection de l'opérateur contre la projection de pièces lors du chargement.

EN Advantages

- All-in-one station for all tools and devices.
- High mobility.
- More safety and comfort for each operation.
- Prepared for mounting of force tester.

ES Ventajas

- Estación todo en uno para herramientas y kits.
- Alta movilidad.
- Mayor seguridad y comodidad para cada operación.
- Preparada para el montaje de tester de fuerza.

EN Technical Data

- 3 drawers (one with oil drain pan) + compartment closed with door for storing kits and tools.
- Worktop 1400 x 685 x 40 mm.
- LED light with switch.
- Compressed air supply 1/4".
- 3 power sockets.
- The electrical plug is not included.
- Parallel vice 130 mm.
- Operator's protection against projection of parts during charging.

ES Datos técnicos

- 3 cajones (1 con bandeja de recogida de aceite) + puerta para guardar kit y herramientas.
- Encimera 1400 x 685 x 40 mm.
- Lámpara LED con interruptor.
- Conexión de aire comprimido de 1/4".
- 3 enchufes eléctricos.
- El enchufe eléctrico no está incluido.
- Tornillo de banco 130 mm.
- Protección del operador contra la proyección de piezas durante la carga.

DE Vorteile

- All-in-one Servicestation für Werkzeuge und Reparatursätze.
- Hohe Mobilität.
- Mehr Sicherheit und Komfort bei jedem Arbeitsschritt.
- Aufnahme zur Befestigung des Kraftmessgeräts.

PT Benefícios

- Todas as ferramentas e kit de carregamento em um só lugar.
- Total mobilidade.
- Maior segurança e comodidade.
- Já preparada para o Dinamometro.

DE Technische Daten

- 3 Schubladen (davon eine mit Ölauffangwanne) + mit Tür verschlossenes Fach zur Aufbewahrung von Reparatursätzen und Werkzeugen.
- Arbeitsplatte 1400 x 685 x 40 mm.
- LED-Leuchte mit Schalter.
- 1/4" Druckluftanschluss.
- 3 Steckdosen.
- Der Stromstecker ist nicht enthalten.
- Parallelschraubstock 130 mm.
- Schutz des Bedieners gegen das Herausspringen von Teilen beim Befüllen.

PT Dados técnicos

- 3 Gavetas (1 com espaços demarcados para os kits de manutenção) as outras para armazenar instrumentos e ferramentas.
- Mesa de trabalho de 1400 x 685 x 40mm.
- Lampada de LED com interruptor.
- Saída para ar comprimido 1/4".
- 3 tomadas.
- A ficha eléctrica não está incluída.
- Morsa paralela de 130mm.
- Proteção para o operador enquanto carrega os cilindros.

ACCESSORIES - DIGITAL FORCE TESTER



code 39FT02000

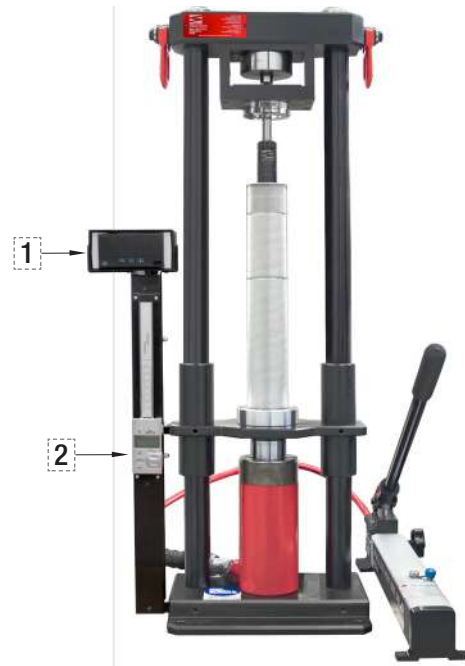

code 39FT00250B ■

code 39FT00500B ■

	Measuring range	0 ÷ 2000 daN <i>0 ÷ 4496 lb</i>	0 ÷ 250 daN <i>0 ÷ 562 lb</i>	0 ÷ 500 daN <i>0 ÷ 1124 lb</i>
	Recommended for FO	0 ÷ 1500 daN <i>0 ÷ 3372 lb</i>	0 ÷ 250 daN <i>0 ÷ 562 lb</i>	250 ÷ 500 daN <i>562 ÷ 1124 lb</i>
	Max. length	430 mm <i>16.93 inch</i>	430 mm <i>16.93 inch</i>	430 mm <i>16.93 inch</i>
	Max. diameter	75 mm <i>2.95 inch</i>	45 mm <i>1.77 inch</i>	45 mm <i>1.77 inch</i>
	Accuracy according EN ISO 7500-1	-	CLASS 1 (± 1%)	CLASS 1 (± 1%)
	Power supply	Battery (included)	100 - 240 VAC 50-60 Hz	100 - 240 VAC 50-60 Hz
	L x P x H	255 x 310 x 1300 mm <i>10.04 x 12.20 x 51.18 inch</i>	450 x 250 x 947 mm <i>17.72 x 9.84 x 37.28 inch</i>	450 x 250 x 947 mm <i>17.72 x 9.84 x 37.28 inch</i>
	Weight	■ 28 Kg <i>61.73 lb</i>	83,5 Kg <i>184.09 lb</i>	83,5 Kg <i>184.09 lb</i>

code 59VCATM03



DIGITAL DISPLAY

code 59RE150



DIGITAL LINEAR SCALE



code 39FT07500B ■

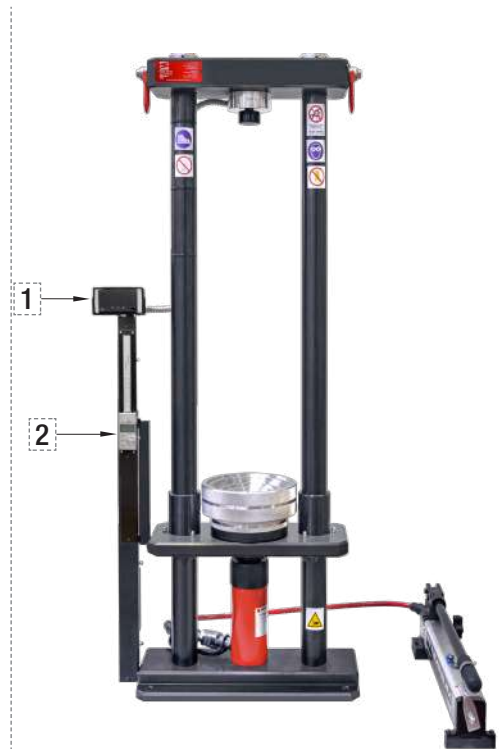

code 39FT20000 ■

	Measuring range	0 ÷ 7500 daN 0 ÷ 16861 lb	0 ÷ 20000 daN 0 ÷ 44962 lb
	Recommended for FO	500 ÷ 7500 daN 1124 ÷ 16861 lb	7500 ÷ 20000 daN 16861 ÷ 44962 lb
	Max. length	400 mm 15.75 inch	760 mm 29.92 inch
	Max. diameter	120 mm 4.72 inch	195 mm 47.68 inch
	Accuracy according EN ISO 7500-1	CLASS 1 (± 1%)	CLASS 1 (± 1%)
	Power supply	100 - 240 VAC 50-60 Hz	100 - 240 VAC 50-60 Hz
	L x P x H	450 x 260 x 1350 mm 17.72 x 10.24 x 53.15 inch	577x250x1317 mm 22.72 x 9.84 x 51.85 inch
	Weight	88,5 Kg 195.11lb	197 Kg 434 lb

code 59VCATM03



code 59RE150



code 39SPB01A

code 39SPB02A

p.321

IT Cos'è EYE?

Sistema digitale alimentato a batteria per il controllo della pressione di cilindri ad azoto autonomi o di impianti collegati. Il sistema visualizza la pressione quando viene premuto il tasto e indica se accettabile attraverso i led rosso/verde (valore di soglia impostabile). Display in bar, psi o MPa.

EN What's EYE?

Battery-powered digital system for pressure control of self-contained nitrogen cylinders or linked systems. The system displays the pressure when the key is pressed and indicates if it is acceptable through the red/green LEDs (settable threshold value). Display in bar, psi or MPa.

DE Was ist EYE?

Batteriebetriebenes digitales System zur Druckregelung von geschlossenen Stickstoffflaschen oder angeschlossenen Systemen. Das System zeigt den Druck beim Drücken der Taste an und zeigt über die roten/grünen LEDs an, ob dieser akzeptabel ist (einstellbarer Schwellenwert). Anzeige in bar, psi oder MPa.

FR Qu'est-ce que c'est EYE?

Système numérique alimenté par batterie pour le contrôle de la pression des bouteilles d'azote autonomes ou des systèmes connectés. Le système affiche la pression à l'appui sur la touche et indique si elle est acceptable par les leds rouges/vertes (valeur seuil paramétrable). Affichage en bar, psi ou MPa.

ES ¿Qué es EYE?

Sistema digital alimentado por batería para el control de presión de cilindros de nitrógeno autónomos o sistemas conectados. El sistema muestra la presión cuando se presiona la tecla e indica si es aceptable a través de los LED rojo/verde (valor umbral configurable). Visualización en bar, psi o MPa.

PT O que é EYE?

Sistema digital alimentado por bateria para controle de pressão de cilindros de nitrogênio independentes ou sistemas conectados. O sistema exibe a pressão quando a tecla é pressionada e indica se ela é aceitável através dos LEDs vermelho/verde (valor limite configurável). Exibição em bar, psi ou MPa.



new

IT Vantaggi EYE

- Visualizzazione e lettura rapida
- Riduzione dei costi di manutenzione degli stampi
- Interfaccia semplice
- Piccole dimensioni
- Alimentazione elettrica con batterie a lunga durata

EN EYE benefits

- Quick visualization and reading
- Reduction of maintenance costs of dies
- Simple interface
- Small size
- Power supply with long-lasting battery

DE Vorteile von EYE

- Schnelle Anzeige und Ablesbarkeit
- Reduzierung der Wartungskosten der Werkzeuge
- Einfache Schnittstelle
- Platzsparend
- Stromversorgung über langlebige Batterie

FR Avantages EYE

- Visualisation et lecture rapide
- Réduction des coûts de maintenance des moules
- Interface simple
- Dimensions compactes
- Alimentation électrique avec batterie longue durée

ES Ventajas EYE

- Visualización y lectura rápida
- Reducción de los costes de mantenimiento de los troqueles
- Interfaz simple
- Tamaño pequeño
- Fuente de alimentación con batería de larga duración

PT Vantagens EYE

- Rápida leitura e visualização da pressão
- Redução dos custos de Manutenção do ferramental
- Interface simples
- Dimensões reduzidas
- Fonte de alimentação com bateria de longa duração

Battery lifetime	Measuring range:	Accuracy	Alarms	°F °C	IP65
> 2000 readings	0 ÷ 600 bar 0 ÷ 8700 psi 0 ÷ 60 MPa	±2,0% f.s., ±1 digit whichever is greater	Low pressure (adjustable), High pressure (fixed), Sensor malfunction, Low battery	0 - 80 °C 32 - 176 °F	

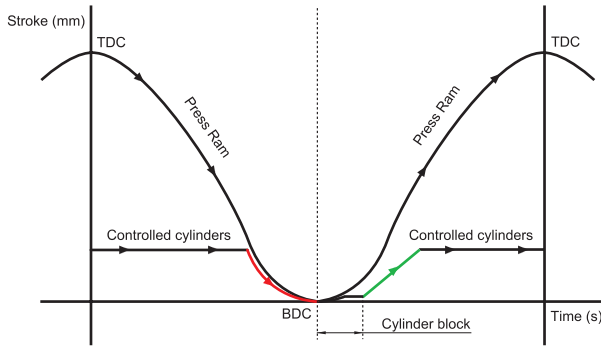

IT Vantaggi del sistema Special Springs

- Ritorno degli steli dei cilindri indipendente dal ciclo pressa.
- Velocità di ritorno degli steli dei cilindri indipendente dalla velocità della pressa.
- Velocità di ritorno degli steli dei cilindri costante e regolabile.
- Forza di contrasto dei cilindri costante, crescente o decrescente da inizio a fine ciclo di lavoro.
- Utilizzo parziale della corsa dei cilindri possibile senza apportare modifiche al sistema.
- Continuo smaltimento del calore con scambiatori di calore sull'unità di comando.
- Massima affidabilità del sistema garantita dal fluido idraulico continuamente rigenerato.

FR Les avantages de special Springs Système

- Course de retour des pistons indépendante du cycle de la presse.
- Vitesse de remontée des pistons indépendante de la vitesse de la presse.
- Vitesse de remontée des pistons constante et réglable.
- Force d'opposition du vérin : constante, croissante ou décroissante du début à la fin du cycle de travail.
- Utilisation partielle de la course possible sans modification du système.
- Dispersion continue de la chaleur avec un échangeur thermique sur l'unité de commande.
- Fiabilité maximale du système garantie par le renouvellement permanent du fluide hydraulique.

EN Advantages of the special Springs System

- Return stroke of the gas spring rods independent from press cycle.
- Return speed of gas spring rods independent from press speed.
- Return speed of gas spring rods constant and adjustable.
- Gas spring contrasting force: constant, increasing or decreasing from beginning to end of working cycle.
- Partial use of gas spring stroke possible without system modifications.
- Continuous dispersal of the heat by heat exchanger on the command unit.
- Maximum system reliability guaranteed by the constant renewal of the hydraulic fluid.

ES Ventajas del sistema Special Springs

- Retorno del cilindro independiente del ciclo de la prensa.
- Velocidad de retorno del vástago independiente del ciclo de la prensa.
- Velocidad de retorno del vástago constante y regulable.
- Fuerza de contraste del cilindro: constante, superior o inferior de principio a fin del ciclo de trabajo.
- Posibilidad de utilizar la carrera parcialmente sin necesidad de modificar el sistema.
- Continua dispersión del calor a través de un intercambiador de calor en la unidad de control.
- Fiabilidad máxima del sistema garantizada por la constante renovación del fluido en el Sistema.

DE Die vorteile des systems von Special Springs

- Rücklauf der Kolbenstangen unabhängig vom Pressenzklus.
- Rücklaufgeschwindigkeit der Kolbenstangen unabhängig von der Pressengeschwindigkeit.
- Rücklaufgeschwindigkeit der Kolbenstangen konstant und einstellbar.
- Gegenkraft der Zylinder konstant, zunehmend oder abnehmend von Anfang bis Ende des Arbeitszyklus.
- Teilnutzung des Hubs der Zylinder möglich, ohne dass dazu Systemänderungen erforderlich sind
- Kontinuierliche Ableitung der Wärme, durch einen Wärmeaustauscher im Hydraulikaggregat.
- Maximale Zuverlässigkeit des Systems, garantiert durch eine kontinuierliche Regenerierung des Hydrauliköls.

PT Vantagens do sistema Special Springs

- Curso de retorno do cilindro independente do ciclo da prensa.
- Velocidade de retorno do êmbolo independente do ciclo da prensa.
- Velocidade de retorno do êmbolo constante ou regulável.
- Força do cilindro: constante ou variável (maior ou menor força) do início ao fim do ciclo de trabalho.
- Possibilidade de se usar também parcialmente o curso sem ter necessidade de modificar o sistema.
- Contínua dissipação do calor com um permutador de calor na unidade de comando.
- Máxima fiabilidade da ferramenta garantida pela renovação constante do fluido no sistema.

IT Richiedere o scaricare dal sito www.specialsprings.com il catalogo.

EN Ask for or download the catalog from our web site www.specialsprings.com.

DE Den Katalog von unsere Internetseite www.specialsprings.com herunterladen oder anfordern

FR Demandez ou téléchargez notre catalogue à partir de notre site web www.specialsprings.com.

ES Solicitar o descargar de la web www.specialsprings.com el catálogo.

PT Requerer ou descarregar no site www.specialsprings.com o catálogo.



NITRO STRIP



IT Carichi forti - estrattore a gas con forza di estrazione regolabile. Montaggio diretto su portapunzoni standard per punzoni ball-lock o con testa ISO 8020.

EN Heavy duty - Nitrogen gas stripper with adjustable force. Direct mounting on standard retainers for Ball-Lock or ISO 8020 punches.

DE Schwere Belastung - Gasdruck-Abstreifer mit einstellbarer Kraft. Direktmontage auf Standard-Stempelhalteplatten für Stempel mit Ball-Lock-System oder nach ISO 8020.

FR Charge lourde - Unité de dévêtissage à gaz avec force réglable. Montage direct sur les plaques porte-poinçon standard pour poinçons avec système Ball-Lock ou selon ISO 8020.

ES Carga pesada - Extractor de punzones de nitrógeno con fuerza ajustable. Montaje directo en porta punzones estándares para punzones Ball-Lock o según ISO 8020.

PT Carga pesada - Perfuradores de nitrogênio com força ajustável. Montagem directa em porta punções padrão para punções Ball-Lock ou segundo ISO 8020.



IT Richiedere o scaricare dal sito www.specialsprings.com il catalogo.

EN Ask for or download the catalog from our web site www.specialsprings.com.

DE Den Katalog von unsere Internetseite www.specialsprings.com herunterladen oder anfordern

FR Demandez ou téléchargez notre catalogue à partir de notre site web www.specialsprings.com.

ES Solicitar o descargar de la web www.specialsprings.com el catálogo.

PT Requerer ou descarregar no site www.specialsprings.com o catálogo.



IT Caratteristiche

- Montaggio diretto su portapunzoni standard
- Testina estrattore e premilamiera lunga o corta in bronzo guidata, rimovibile e sagomabile
- Testina anti-rotazione con 8 mm di corsa
- 4 codici colore standard indicativi del carico/forza
- 8 modelli per punzoni da 10 a 40 mm di diametro
- Forza a contatto fino a 1880 daN / 4200 lbf
- Forza di estrazione fino a 3200 daN / 7200 lbf
- Forza di estrazione regolabili
- Collegabile con altre unità NITRO STRIP per massima flessibilità
- Sicurezza OPAS inclusa come standard
- Dimensioni compatte

EN Features

- Direct mounting on standard retainers
- Bronze stripping head that is guided, demountable and machinable. Available short or long
- Anti-rotation head with 8 mm stroke
- 4 standard color codes for different forces/loads
- 8 models with punch diameter from 10 to 40 mm
- Contact force as high as 1880 daN / 4200 lbf
- Stripping force as high as 3200 daN / 7200 lbf
- Adjustable stripping force
- Connectable with other NITRO STRIP units for maximum flexibility
- OPAS built-in as standard
- Compact design

DE Merkmale

- Direktmontage auf Standard-Stempelhalteplatten
- Abstreiferkopf aus Bronze, geführt, abnehm- und bearbeitbar. Verfügbar kurz oder lang
- Abstreiferkopf verdrehgesichert, mit einem Hub von 8 mm
- 4 Standard-Farbcodes für verschiedene Kräfte/ Belastungen
- 8 Modelle mit Stempeldurchmesser von 10 bis 40 mm
- Kontaktkraft bis zu 1880 daN / 4200 lbf
- Abstreiferkraft bis zu 3200 daN / 7200 lbf
- Abstreiferkraft einstellbar
- Anschließbar mit anderen NITRO STRIP Einheiten für maximale Flexibilität
- OPAS standardmäßig eingebaut
- Kompaktes Design

FR Caractéristiques

- Montage direct sur les plaques porte-poinçon standard
- Tête de dévêtisseur de bronze, guidée, démontable et qui peut être usinée. Disponible courte ou longue
- Tête de dévêtisseur résistant à la torsion, avec une course de 8 mm
- 4 codes couleur standard avec différentes forces/charges
- 8 modèles avec diamètres de poinçon de 10 à 40 mm
- Force de contact jusqu'à 1880 daN / 4200 lbf
- Force de dévêtisseur jusqu'à 3200 daN / 7200 lbf
- Force de dévêtisseur ajustable
- Possibilité de relier avec autres unités NITRO STRIP pour une flexibilité maximale
- OPAS installée de série - Design compact

ES Características

- Montaje directo en porta punzones estándares
- Pisador bronce guiado, desmontable y mecanizable. Disponible con 2 longitudes.
- Con antigiro y carrera de 8 mm
- 4 códigos de colores estándares según la fuerza/carga requerida
- 8 modelos para diámetros de punzón de 10 a 40 mm
- Fuerza de contacto hasta 1880 daN / 4200 lbf
- Fuerza de extracción hasta 3200 daN / 7200 lbf
- Fuerza de extracción ajustable
- Conectable a otras unidades NITRO STRIP para una máxima flexibilidad
- OPAS incluida como estandar
- Diseño compacto

PT Características

- Montagem directa em porta punções padrão
- Cabeça do destacador em bronze, guiada, removível e de fácil usinagem. Disponível curta ou longa
- Cabeça anti-rotação com curso de 8 mm
- 4 códigos de cores padrão para diferentes forças/cargas
- 8 modelos com diâmetro da punção de 10 a 40 mm
- Força de contato até 1880 daN / 4200 lbf
- Força de extração até 3200 daN / 7200 lbf
- Força de extração pode ser ajustada
- Possibilidade de interligação com outras unidades NITRO STRIP para o máximo de flexibilidade
- OPAS como padrão
- Design compacto

IT Carichi forti - estrattore a gas con forza di estrazione regolabile. Montaggio diretto con punzoni ISO 8020.

EN Heavy duty - Nitrogen gas stripper with adjustable force. Direct mounting with ISO 8020 punches.

DE Schwere Belastung - Gasdruck-Abstreifer mit einstellbarer Kraft. Direktmontage mit Stanzen ISO 8020.

FR Charge lourde - Unité de dévêtissage à gaz avec force réglable. Montage direct avec poinçons ISO 8020.

ES Carga pesada - Extractor de punzones de nitrógeno con fuerza ajustable. Montaje directo con punzones ISO 8020.

PT Carga pesada - Perfuradores de nitrogénio com força ajustável. Montagem direta com punções ISO 8020.

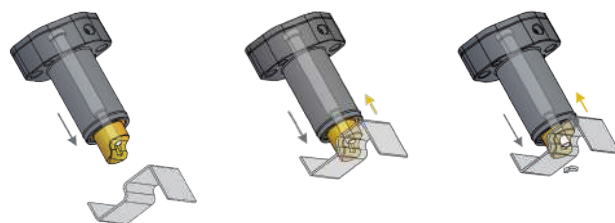
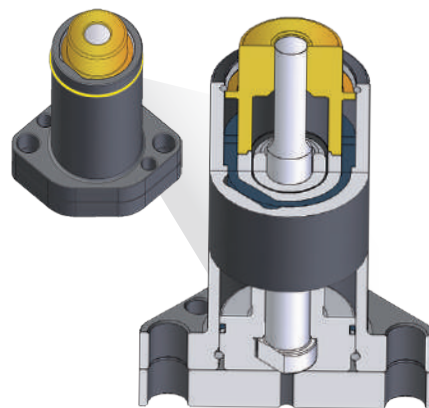

IT Richiedere o scaricare dal sito www.specialsprings.com il catalogo.

EN Ask for or download the catalog from our web site www.specialsprings.com.

DE Den Katalog von unsere Internetseite www.specialsprings.com herunterladen oder anfordern

FR Demandez ou téléchargez notre catalogue à partir de notre site web www.specialsprings.com.

ES Solicitar o descargar de la web www.specialsprings.com el catálogo.

PT Requerer ou descarregar no site www.specialsprings.com o catálogo.



IT Caratteristiche

- Testa premilamiera estraibile e sagomabile
- Facile posizionamento e fissaggio
- Elevata forza di estrazione
- Dimensioni compatte
- Adatto per punzoni ISO 8020
- Non è richiesto l'uso di altro portapunzone
- Ideale per uso combinato con unità cam

EN Features

- Stripper head removable and mouldable
- Easy positioning
- High and adjustable holding and stripping force
- Compact dimensions
- Suitable for ISO 8020 shoulder style punch
- Doesn't require the use of standard retainer
- Ideal for combined use with cam unit

DE Merkmale

- Niederhalterkopf herausnehmbar und mit bearbeitbarer Kontur
- Einfache Positionierung
- Hohe und einstellbare Niederhalter- und Abstreiferkraft
- Kompakte Größe
- Geeignet für Schneidstempel ISO 8020
- Andere Stempelhalteplatten sind nicht erforderlich
- Ideal für den Einsatz in Kombination mit Schiebern

FR Caractéristiques

- Tête de bronze que peut être modelée et extraite
- Positionnement facile
- Force élevée de extraction
- Dimensions compactes
- Indiqué pour poinçons ISO 8020
- Il ne demande pas l'emploi de autre poinçon
- Idéal à utiliser avec l'unité CAM

ES Características

- Pisador desmontable y mecanizable
- Fácil posicionamiento y amarre
- Fuerza de extracción muy elevada y ajustable
- Dimensiones compactas
- Apropiado para punzón con cabeza ISO 8020
- No requiere uso de porta punzón
- Ideal para utilizar con carro de punzonado

PT Características

- Cabeça de corte fácil remoção e maquinavel
- Fácil posicionamento
- Fixação alta e ajustável e força de corte
- Dimensões compactas
- Adequado para punção o ISO 8020 respigado
- Não necessita do uso de um retentor normalizado
- Ideal para uso combinado com uma unidade CAM





EUROPE

Headquarters

Special Springs S.r.l.
Via Nardi, 124/A
36060 Romano d'Ezzelino (VI) - ITALY
tel. +39 0424 539181
email: info@specialsprings.com
www.specialsprings.com

French Subsidiary

Special Springs France
Impasse de la Birbadière
49650 Allonnes - FRANCE
Ph. +33 (0)6 37 62 76 62
email: contact@specialsprings.fr
www.specialsprings.com

AMERICA

North American Subsidiary

Special Springs LLC
7707 Ronda Drive, Canton
Michigan 48187 - USA
Ph. +1 734.892.2324
email: info@specialspringsna.com
www.specialspringsna.com

South American Subsidiary

Special Springs do Brasil
Avenida dom Pedro I, 2156 - Vila Pires
09130-012 Santo André / SP - BRASIL
Ph. +55 11 2324 3545
email: comercial@specialsprings.com.br
www.specialsprings.com.br

ASIA

Indian Subsidiary

Global Special Springs pvt. Ltd.
Survay no. 69/2 - Chandarda, Tal. Kadi
Dist. Mehesana (Ahmedabad - Mehesana Highway)
Gujarat, 382705 - INDIA
Ph. +91 2764 273065
email: info@globalspecialsprings.com
www.specialsprings.com

Catalog code

9800C04600226

