

**WEAR PLATE SELF-LUBRICATING  
GLEITPLATTE BRONZE MIT FESTSCHMIERSTOFF  
PIASTRA GUIDA AUTOLUBRIFICANTE**

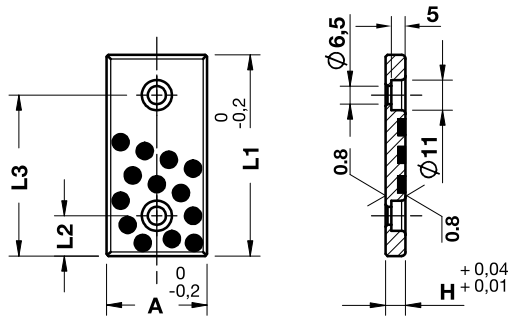

**FORM A**

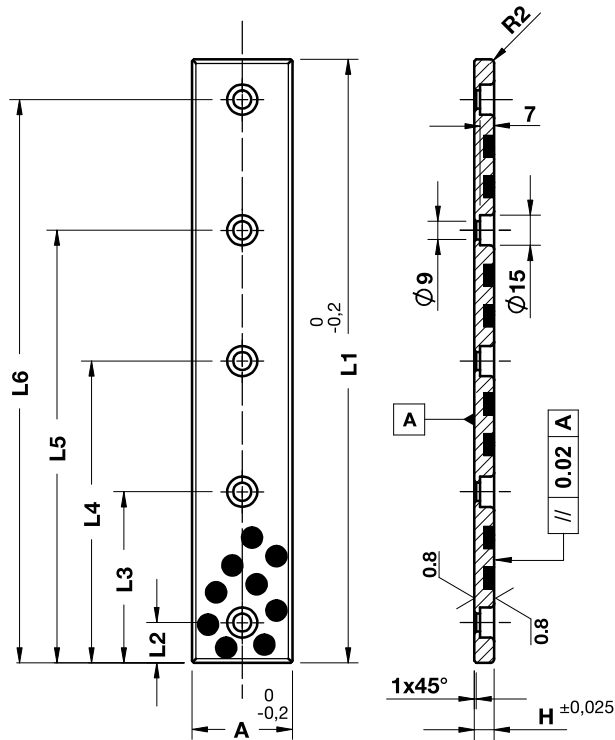

**FORM B**

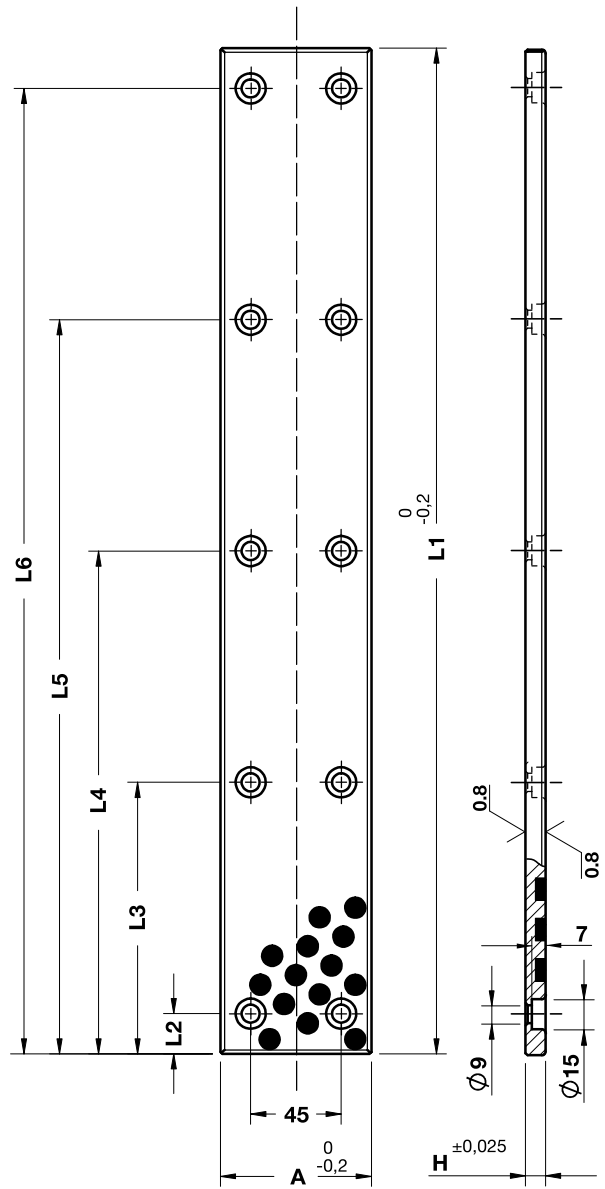

**FORM C**

Notes

**Material:** Bronze + Graphite  
**HB** > 190

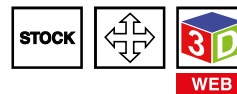

	Art.	A=18	H=10	L1=100
	E40.08.	018	10	100

OMCR CODE	A	H	L1	L2	L3	L4	L5	L6	FORM
E40.08.01810075	18	10	75	15	60	-	-	-	A
E40.08.01810100	18	10	100	25	75	-	-	-	A
E40.08.01810125	18	10	125	25	100	-	-	-	A
E40.08.01810150	18	10	150	25	125	-	-	-	A
E40.08.02810075	28	10	75	15	60	-	-	-	A
E40.08.02810100	28	10	100	25	75	-	-	-	A
E40.08.02810125	28	10	125	25	100	-	-	-	A
E40.08.02810150	28	10	150	25	125	-	-	-	A
E40.08.03510100	35	10	100	20	80	-	-	-	A
E40.08.03510150	35	10	150	20	75	130	-	-	B
E40.08.03510200	35	10	200	20	75	125	180	-	B
E40.08.03510250	35	10	250	20	90	160	230	-	B
E40.08.03510300	35	10	300	20	85	150	215	280	B
E40.08.03510350	35	10	350	20	100	175	250	330	B
E40.08.03810075	38	10	75	15	60	-	-	-	A
E40.08.03810100	38	10	100	25	75	-	-	-	A
E40.08.03810125	38	10	125	25	100	-	-	-	A
E40.08.03810150	38	10	150	25	125	-	-	-	A
E40.08.04810075	48	10	75	15	60	-	-	-	A
E40.08.04810100	48	10	100	25	75	-	-	-	A
E40.08.04810125	48	10	125	25	100	-	-	-	A
E40.08.04810150	48	10	150	25	125	-	-	-	A
E40.08.05010100	50	10	100	20	80	-	-	-	B
E40.08.05010150	50	10	150	20	75	130	-	-	B
E40.08.05010200	50	10	200	20	75	125	180	-	B
E40.08.05010250	50	10	250	20	90	160	230	-	B
E40.08.05010300	50	10	300	20	85	150	215	280	B
E40.08.05010350	50	10	350	20	100	175	250	330	B
E40.08.05010400	50	10	400	20	110	200	290	380	B
E40.08.07510150	75	10	150	20	130	-	-	-	C
E40.08.07510200	75	10	200	20	100	180	-	-	C
E40.08.07510250	75	10	250	20	125	230	-	-	C
E40.08.07510300	75	10	300	20	105	195	280	-	C
E40.08.07510400	75	10	400	20	140	260	380	-	C
E40.08.07510500	75	10	500	20	135	250	365	480	C