

512

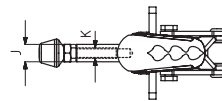

Modell Nr.	Rostfrei (Edelstahl) (STAINLESS)	Schwarz (BLACK)	F1 (N)	F3 (N)	Fi	Andruckspindel (SQUEEZE SCREW)	Hub (STROKE)	Gewicht (WEIGHT) (gr)
					Andruckkraft (YIELD) (F1:Fi)			
512-1	S 512 -	B 512 -	800	970	24:1	M5X35	22	130
512-2	S 512 -	B 512 -	1500	1700	26:1	M6X40	27	270
512-3	S 512 -	B 512 -	2500	2640	27:1	M8X50	38	490
512-5	S 512 -	B 512 -	3500	3700	38:1	M10X70	53	960
512-6	S 512 -	B 512 -	4500	4650	38:1	M10X70	53	1070

F1 : Druckkraft (EXERTING FORCE) , F3 : Haltekraft (HOLDING CAPACITY)
Fi : Anwendungskraft (APPLIED FORCE)

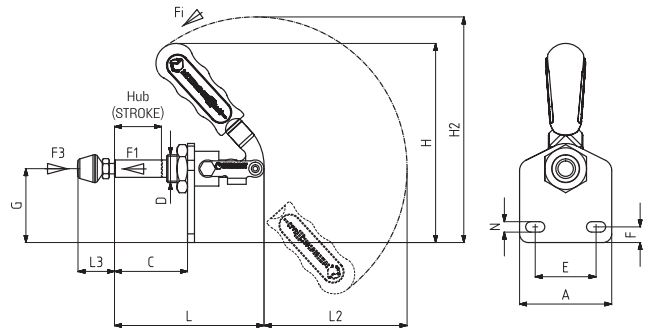

Befestigungsart : mit senkrechtem Fuß
Body Mounting Base: Vertical

Modell Nr.	A	B	C	D	E	F	G	H	H2	J	K	L	L2	L3 Min	L3 Max	M	N
512-1	44		34	M12 x 1,5	21,5 - 31,5	8,5	35	88	100	8	M5	69	60	15	38		5,5x10,5
512-2	53		42	M16 x 1,5	30 - 40	9	42,5	114	129	10	M6	86	80	19	46		6x11
512-3	60		56	M20 x 1,5	33,5 - 42,5	12,5	52	158	161	12	M 8	116	80	24	58		6,5x11
512-5	78		75	M24 x 1,5	42 - 57	15	64,5	178	206	14	M10	155	135	32	74		8,5x16
512-6	78		75	M24 x 1,5	42 - 57	15	64,5	178	206	16	M10	155	135	32	74		8,5x16

513



Modell Nr.	Rostfrei (Edelstahl) (STAINLESS)	Schwarz (BLACK)	F1 (N)	F3 (N)	Fi	Andruckspindel (SQUEEZE SCREW)	Hub (STROKE)	Gewicht (WEIGHT) (gr)
					Andruckkraft (YIELD) (F1:Fi)			
513-1	S 513 -	B 513 -	800	970	24:1	M5X35	22	90
513-2	S 513 -	B 513 -	1500	1700	26:1	M6X40	27	190
513-3	S 513 -	B 513 -	2500	2640	27:1	M8X50	38	360
513-5	S 513 -	B 513 -	3500	3700	38:1	M10X70	53	660
513-6	S 513 -	B 513 -	4500	4650	38:1	M10X70	53	780

F1 : Druckkraft (EXERTING FORCE) , F3 : Haltekraft (HOLDING CAPACITY)
Fi : Anwendungskraft (APPLIED FORCE)

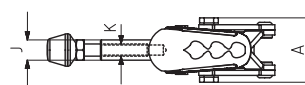
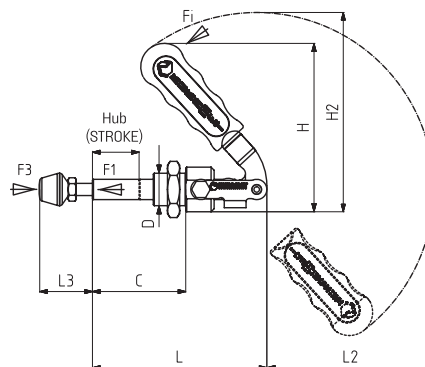

Befestigungsart : ohne Fuß
Body Mounting Base: No Base

Modell Nr.	A	B	C	D	F	G	H	H2	J	K	L	L2	L3 Min	L3 Max	M	N
513-1	28		37	M12 x 1,5			62,5	75	8	M5	69	60	15	38		
513-2	32		46	M16 x 1,5			81,5	97	10	M6	86	80	19	46		
513-3	39		61	M20 x 1,5			100	103	12	M 8	116	80	24	58		
513-5	47		81	M24 x 1,5			131	159	14	M10	155	135	32	74		
513-6	51		81	M24 x 1,5			131	159	16	M10	155	135	32	74		