

241



**Befestigungsart : mit waagrechtm Fuß**  
Body Mounting Base: Horizontal

| Modell Nr. | F1 (N) | F3 (N) | Fi                        | Winkel (ANGLE) (± 5 °) | Gewicht (WEIGHT) (gr) |
|------------|--------|--------|---------------------------|------------------------|-----------------------|
|            |        |        | Andruckkraft (YIELD) (F1) |                        |                       |
| 241-2      | 750    | 2500   | 5;1                       | 120°                   | 325                   |
| 241-4      | 1500   | 5000   | 5;1                       | 120°                   | 1340                  |
| 241-6      | 2000   | 6000   | 5;1                       | 120°                   | 2340                  |

F1 : Druckkraft (EXERTING FORCE) , F3 : Haltekraft (HOLDING CAPACITY) , Fi : Anwendungskraft (APPLIED FORCE)

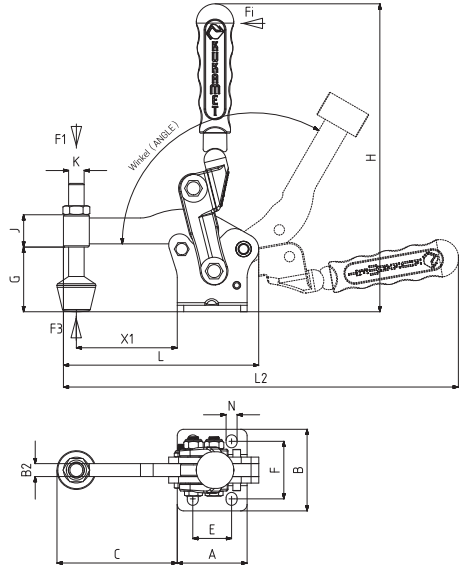

| Modell Nr. | A  | B    | B2 | C    | D | E  | F       | G    | H   | J  | K   | L   | L2  | M | N           | X1   |
|------------|----|------|----|------|---|----|---------|------|-----|----|-----|-----|-----|---|-------------|------|
| 241-2      | 36 | 48,5 | 6  | 52,5 |   | 20 | 30 - 34 | 28,5 | 143 | 15 | M 6 | 89  | 192 |   | 6,5 x 8,5   | 44,5 |
| 241-4      | 54 | 63   | 10 | 88   |   | 30 | 43 - 46 | 49   | 238 | 27 | M12 | 151 | 323 |   | 8,5 x 10    | 78   |
| 241-6      | 70 | 74   | 12 | 111  |   | 45 | 51 - 53 | 68   | 280 | 32 | M12 | 191 | 390 |   | 10,5 x 11,5 | 98,5 |

242



**Befestigungsart : mit senkrechtem Fuß**  
Body Mounting Base: Vertical

| Modell Nr. | F1 (N) | F3 (N) | Fi                        | Winkel (ANGLE) (± 5 °) | Gewicht (WEIGHT) (gr) |
|------------|--------|--------|---------------------------|------------------------|-----------------------|
|            |        |        | Andruckkraft (YIELD) (F1) |                        |                       |
| 242-2      | 750    | 2500   | 5;1                       | 120°                   | 325                   |
| 242-4      | 1500   | 10000  | 5;1                       | 120°                   | 1340                  |
| 242-6      | 2000   | 12000  | 5;1                       | 120°                   | 2340                  |

F1 : Druckkraft (EXERTING FORCE) , F3 : Haltekraft (HOLDING CAPACITY) , Fi : Anwendungskraft (APPLIED FORCE)

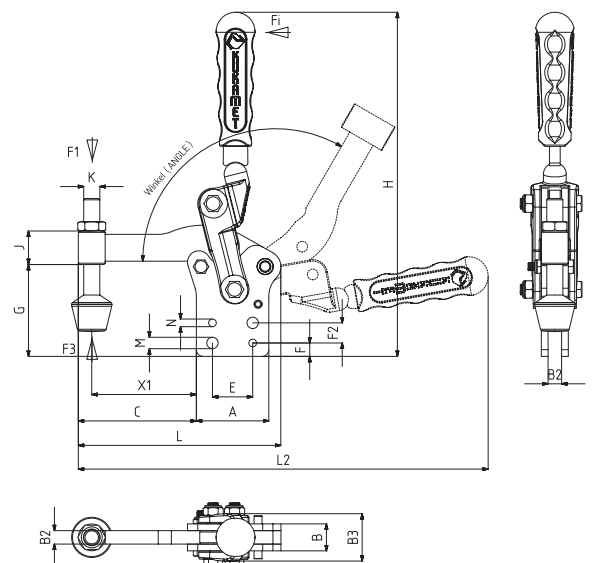

| Modell Nr. | A  | B  | B2 | B3 | C    | D | E  | F  | F2 | G    | H   | J  | K   | L   | L2  | M      | N     | X1   |
|------------|----|----|----|----|------|---|----|----|----|------|-----|----|-----|-----|-----|--------|-------|------|
| 242-2      | 36 | 12 | 6  | 23 | 50,5 |   | 20 | 8  |    | 44,5 | 159 | 15 | M 6 | 89  | 192 | Ø 6,5  |       | 44,5 |
| 242-4      | 54 | 20 | 10 | 36 | 88   |   | 30 | 10 | 15 | 67,5 | 257 | 27 | M12 | 151 | 323 | Ø 8,5  | Ø 5,7 | 78   |
| 242-6      | 70 | 22 | 12 | 46 | 111  |   | 45 | 15 | 20 | 91   | 303 | 32 | M12 | 191 | 390 | Ø 10,5 | Ø 7,7 | 98,5 |