

## PAD RETAINER PIN - STECKBOLZEN - PERNO DI ARRESTO

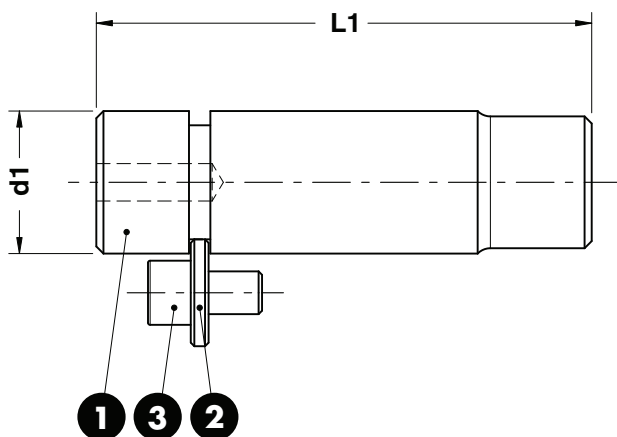

### Notes

- 1** Material: 42CrMo4 - 1000 N/mm<sup>2</sup>
- 2** 39D 828/42
- 3** DIN EN ISO 4762 M12x20



VW CODE
39D 854/2

VW CODE	d1	L1
39D 854/1	32	105
39D 854/2	32	122
39D 854/3	40	139
39D 854/4	40	159
39D 854/5	50	167
39D 854/6	50	192
39D 854/7	63	202
39D 854/8	63	237

Standard VW/Audi

## PAD RETAINER PIN - STECKBOLZEN - PERNO DI ARRESTO

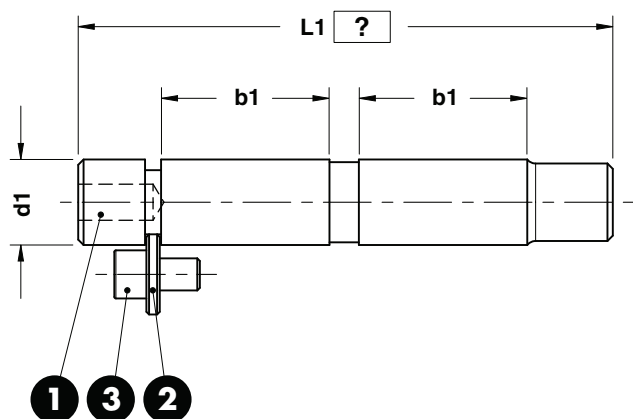

### Notes

- 1** Material: 42CrMo4 - 1000 N/mm<sup>2</sup>
- 2** 39D 828/42
- 3** DIN EN ISO 4762 M12x20



VW CODE	L1=150
39D 854/13	150

VW CODE	b1	d1
39D 854/11	63	32
39D 854/13	80	40
39D 854/15	100	50
39D 854/17	125	63
39D 854/21	80	32
39D 854/23	100	40
39D 854/25	125	50
39D 854/27	160	63

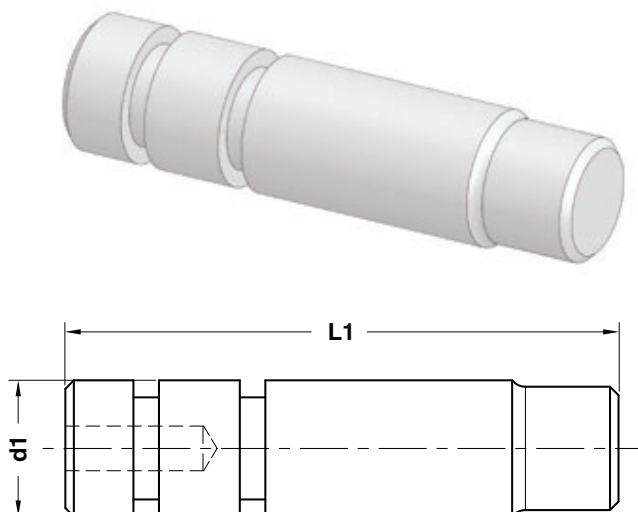
**PAD RETAINER PIN - ABSTECKBOLZEN - PERNO DI ARRESTO**

**Notes**
**Material:** 42CrMo4 - 800÷1000 N/mm<sup>2</sup>

Only for replacement  
Nur für Reparatur  
Solo per riparazione

**VW CODE**
**39D 854/442**

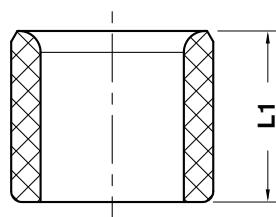
VW CODE	d1	L1
39D 854/441	32	130
39D 854/442	32	147
39D 854/443	40	171
39D 854/444	40	191
39D 854/445	50	207
39D 854/446	50	232
39D 854/447	63	252
39D 854/448	63	287

**BUSH - DÄMPFUNGSBUCHSE - BOCCOLA**

**Notes**
**Material:** Nylatron GSM P30

Only for replacement  
Nur für Reparatur  
Solo per riparazione

**VW CODE**
**39D 855/5**

VW CODE	L1
39D 855/4	32
39D 855/5	40
39D 855/6	50