

## RETAINER BOLT - HALTEBOLZEN - GRUPPO TIRANTE

### Notes

- 1 3 Material:** 42CrMo4
- 2 4 Material:** CK45
- 5 Material:** Elastomer Black 68 SH  
Elastomer Red 90 SH
- 6** Split Pin DIN EN ISO 1234

Only for replacement  
Nur für Reparatur  
Solo per riparazione



Respect the max. load  
Maximale Nutzlast beachten  
Rispettare il carico max.

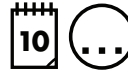

### 39D 650/31 ÷ 38

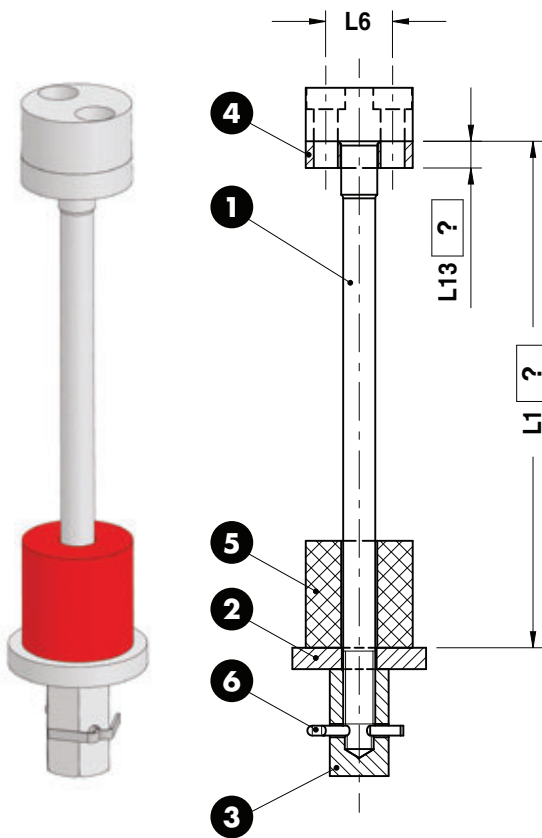

### 39D 650/51 ÷ 58

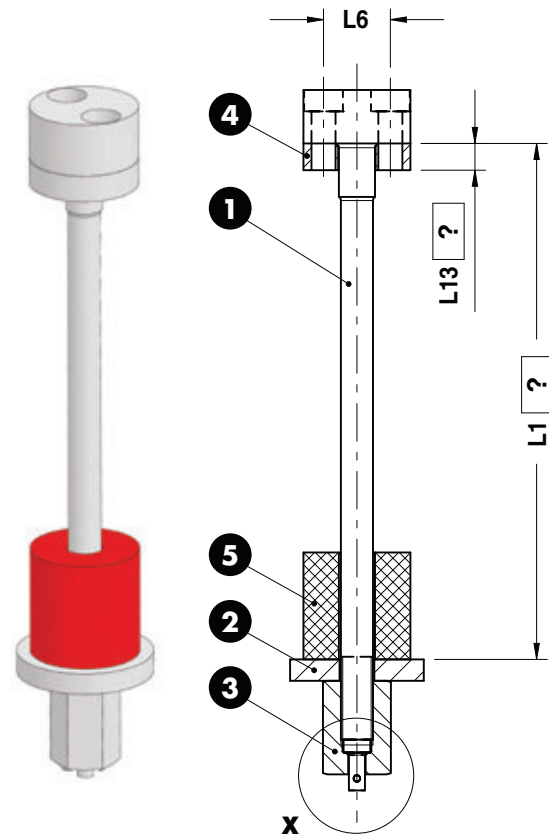

\*Max. capacity load  
Belastbarkeit max.  
Portata massima

\*\*Optional washer, L13=?  
Scheibe optional, L13=?  
Rondella opzionale, L13=?

ORDER EXAMPLE	VW CODE	L1=190	L13=10**
	39D 650/32	190	10

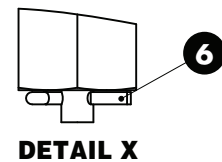

VW CODE	L6	MCL*(N)	Elastomer Shore (SH)	VW CODE	L6	MCL*(N)	Elastomer Shore (SH)
39D 650/31	25	15000	68	39D 650/51	25	15000	68
39D 650/32	30	25000	68	39D 650/52	30	25000	68
39D 650/33	30	25000	68	39D 650/53	30	25000	68
39D 650/34	34	45000	68	39D 650/54	34	45000	68
39D 650/35	25	15000	90	39D 650/55	25	15000	90
39D 650/36	30	25000	90	39D 650/56	30	25000	90
39D 650/37	30	25000	90	39D 650/57	30	25000	90
39D 650/38	34	45000	90	39D 650/58	34	45000	90