

ANTI-REBOUND SLIDE STOP - ARRETERUNG GEGEN RÜCKFEDERUNG - ARRESTO ANTRIMBALZO

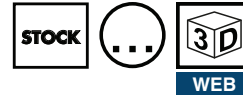

Notes

- 1** Material: CK45
- 2** C17.52
- 3** M10 DIN 912

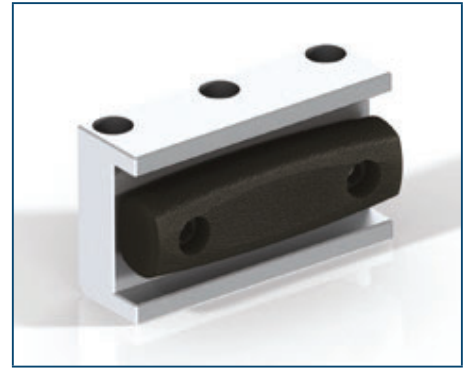
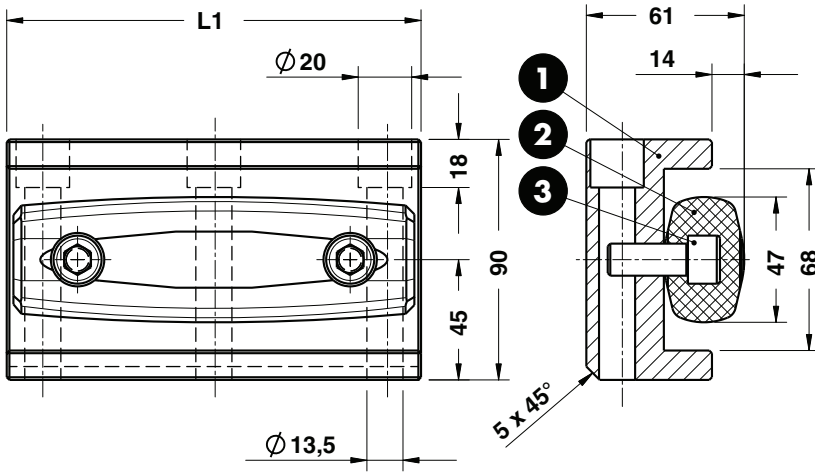
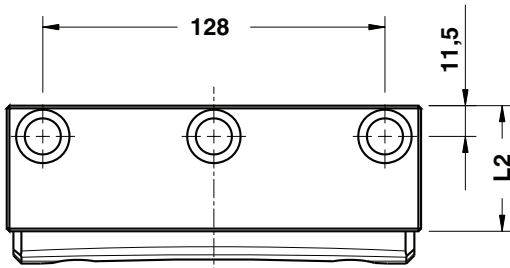

Art.	L1=155	L2=47
C18.07.	155	47

* Maximum absorbed energy
Energia assorbita
Massima energia assorbita

OMCR CODE	L1	L2	F max (kN)	Max Energy Absorbed (J)*	Max Stroke (mm)
C18.07.15547	155	47	47	160	14

Application example

Thermal energy dispersion: 40-60%

