

FLANGE LIFTER - ABSTREIFER - SFLANGIATORE



Do not exceed the stroke
Hub nicht überschreiten
Non superare la corsa

Notes

- 1** Material: EN-GJL300
- 2** Material: Bronze + Graphite - HB>190
- 3** Material: 36NiCrMo4
- 4** M8x25 DIN 912
- 5** Schnorr Ø8
- 6** Gas Spring
- 7** M6x12 DIN 7991

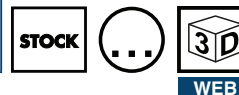
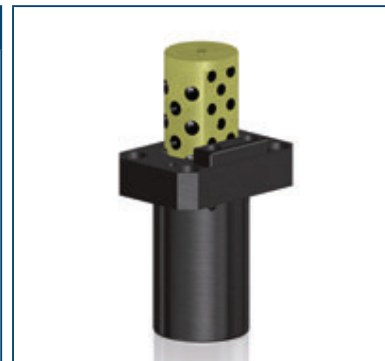

Standard OMCR

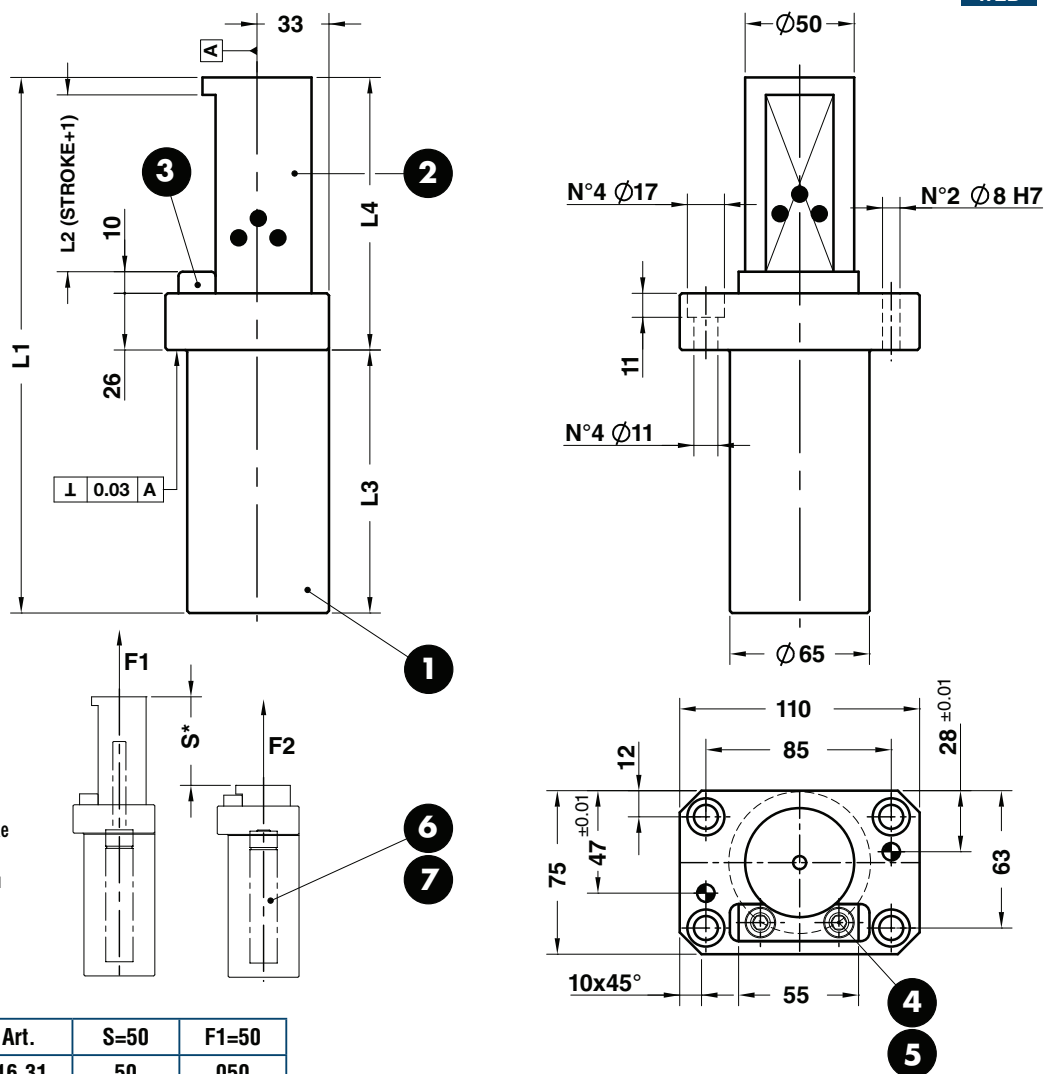

Art.	S=50	F1=50
C16.31.	50	050

OMCR CODE	F1 (daN)	F2 (daN)	L1	L2	L3	L4	S
C16.31.50050	50	86	196	51	101	95	50
C16.31.50100	100	172	196	51	101	95	50
C16.31.50150	150	258	196	51	101	95	50
C16.31.50200	200	344	196	51	101	95	50
C16.31.80050	50	86	256	81	131	125	80
C16.31.80100	100	172	256	81	131	125	80
C16.31.80150	150	258	256	81	131	125	80
C16.31.80200	200	344	256	81	131	125	80