

**BALL CASTER - KUGELROLLENSYSTEM - SFERA PORTANTE**

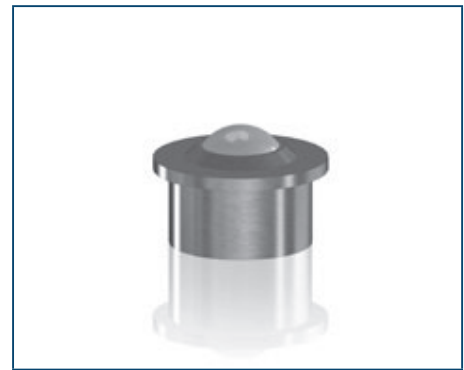

**STOCK**

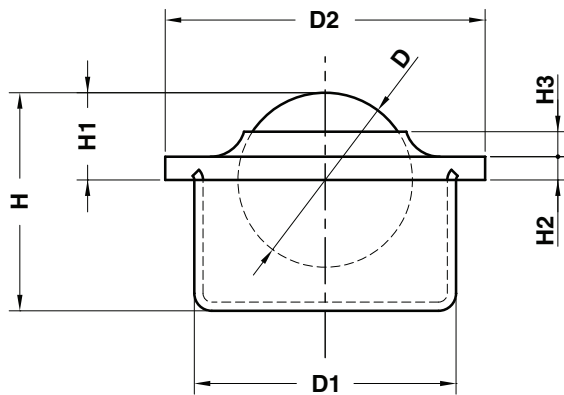

**Notes**

**Material:** Steel

<b>ORDER EXAMPLE</b> 	<b>Art.</b>	<b>D=15</b>
	<b>C16.26.</b>	<b>15</b>

OMCR CODE	D	D1	D2	Max load (daN)	H	H1	H2	H3
<b>C16.26.15</b>	15	24±0,065	31	50	21,5	9,5±0,2	2,8	3,5
<b>C16.26.30</b>	30	45±0,080	55	250	37,5	13,8±0,3	4	4,3