

GAGE FOR SENSOR - EINWEISER FÜR TEILLAGEKONTROLLE - RIFERIMENTO PER SENSORE

Notes

1

Material: CK60

2

Material: St37 - **HRC:** 58÷60

Application example

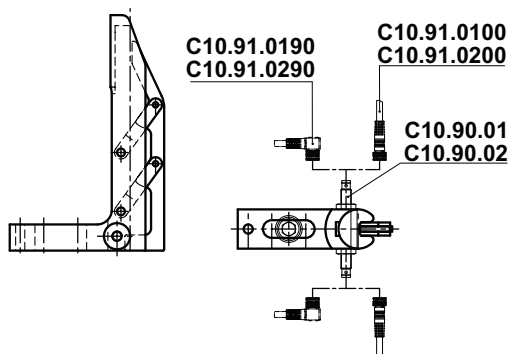

WEB

Standard OMCR

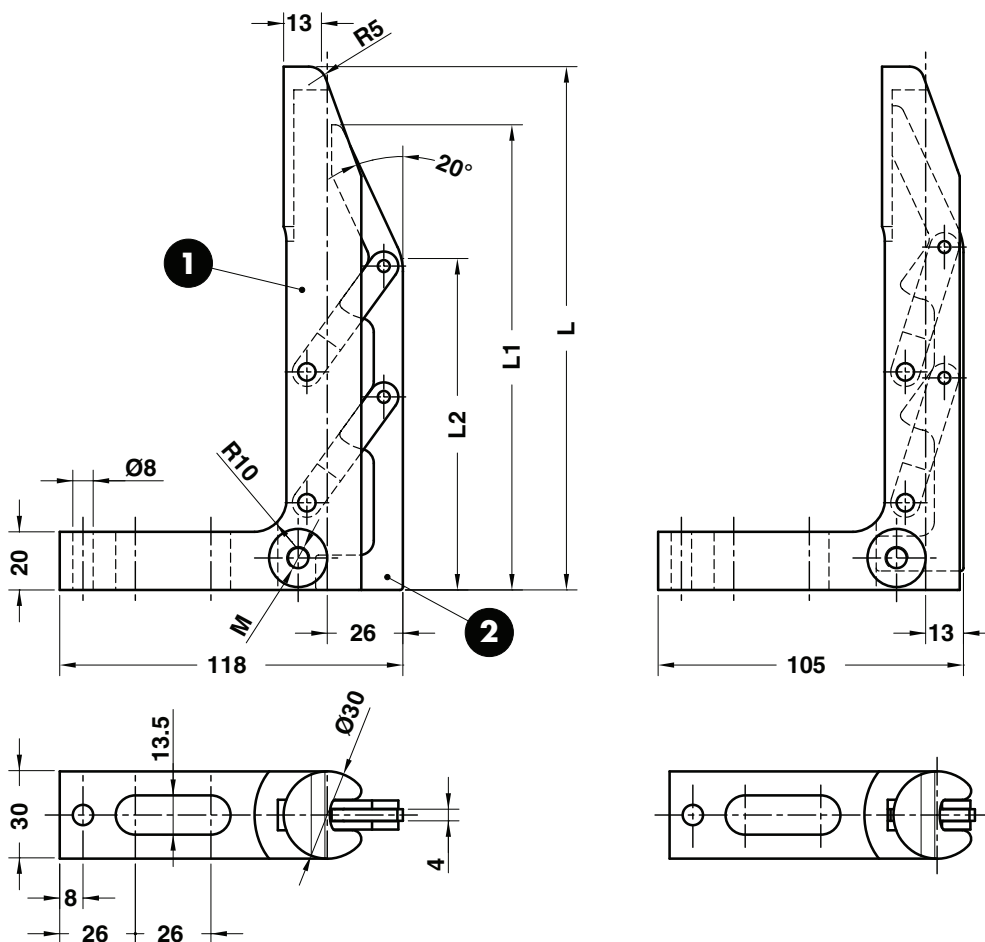

Art.	L=120	L1=113	M=8x1
C10.15.	120	113	08

OMCR CODE	L	L1	L2	M
C10.15.12011308	120	113	78	8x1
C10.15.12011312	120	113	78	12x1
C10.15.15013008	150	130	90	8x1
C10.15.15013012	150	130	90	12x1
C10.15.18016008	180	160	114	8x1
C10.15.18016012	180	160	114	12x1
C10.15.25016008	250	160	114	8x1
C10.15.25016012	250	160	114	12x1
C10.15.25023008	250	230	184	8x1
C10.15.25023012	250	230	184	12x1