

GAGE FOR SENSOR - EINWEISER FÜR TEILLAGEKONTROLLE - RIFERIMENTO PER SENSORE

Notes

- 1** Material: CK60
HRC: 50÷55
- 2** Material: St37

Application example

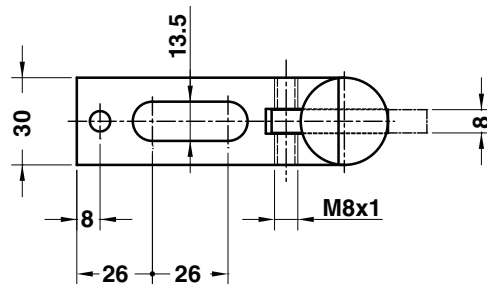
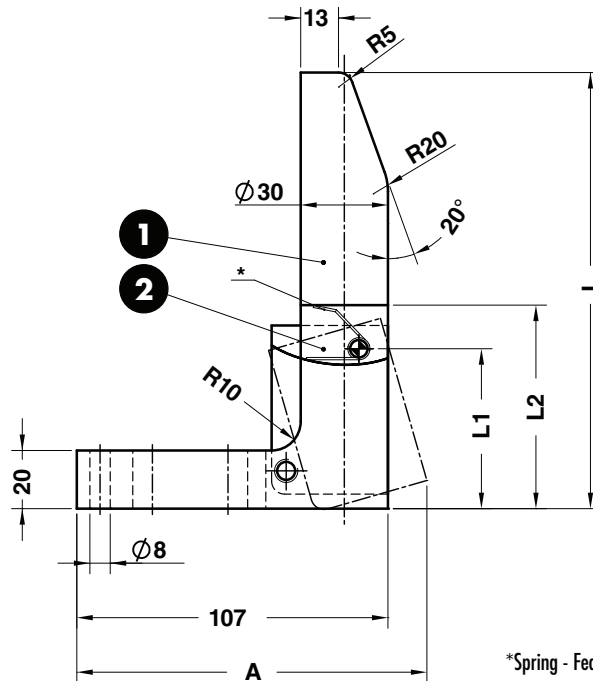
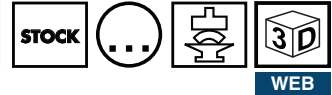
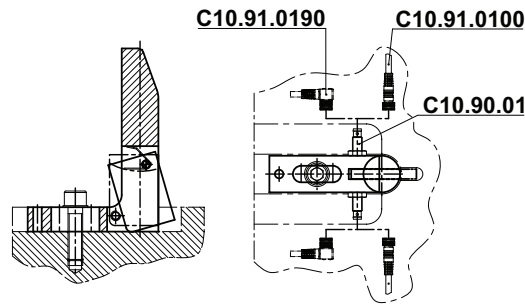

ORDER EXAMPLE	Art.	L=180
	C10.11.	180

OMCR CODE	A	L	L1	L2
C10.11.120	120	120	55	70
C10.11.150	120	150	55	70
C10.11.180	124	180	105	120
C10.11.250	124	250	105	120