

ISO	VDI	General Motors	Peugeot - Citroën
Renault			

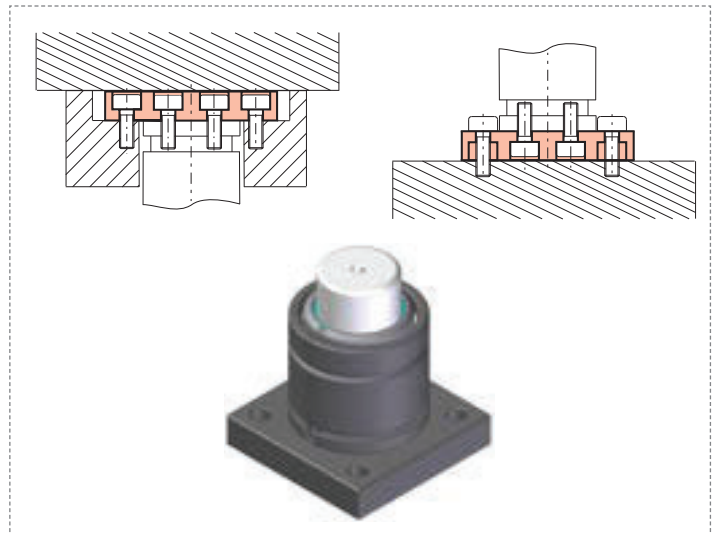

CODE	Reference to standards	A		B		Ø C		D		Ø E		Ø F		Ø G		Ø H		I		L	
		mm	inch	mm	inch	mm	inch	mm	inch	mm	inch	mm	inch	mm	inch	mm	inch	mm	inch	mm	inch
FB 45	1-2-10-19-20	70	2.76	50	1.97	20	0.79	20	0.79	15	0.59	15	0.59	9	0.35	9	0.35	14	0.55	12	0.47
FB 50	1-2-10-19-20	75	2.95	56,5	2.22	20	0.79	20	0.79	15	0.59	15	0.59	9	0.35	9	0.35	14	0.55	12	0.47
FB 63	0	100	3.94	73,5	2.89	20	0.79	20	0.79	15	0.59	18	0.71	9	0.35	11	0.43	12	0.47	12	0.47

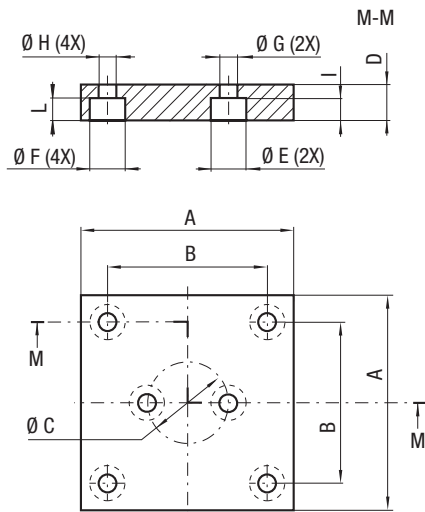
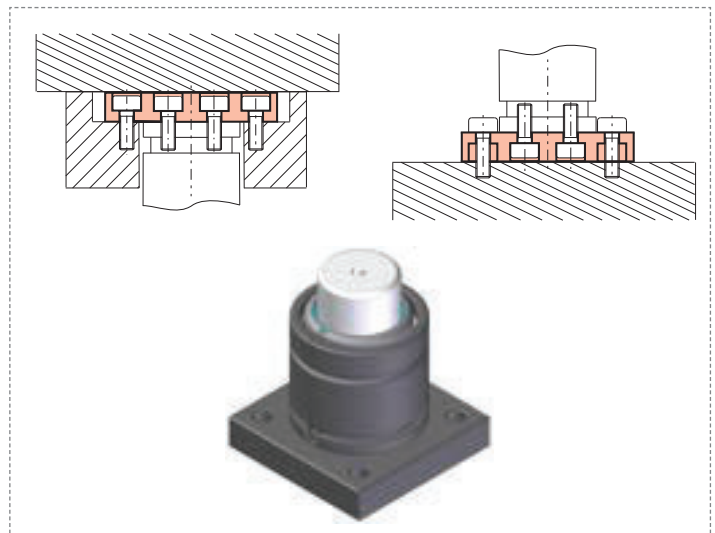
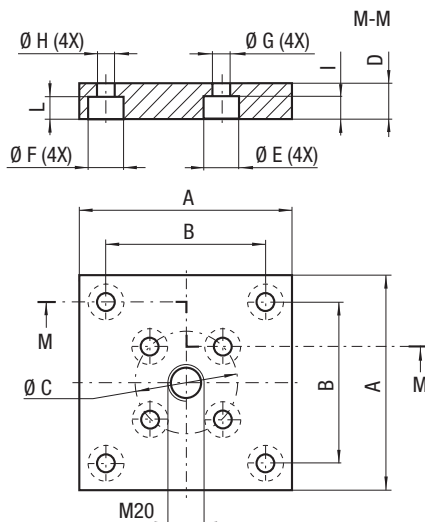

CODE	Reference to standards	A		B		Ø C		D		Ø E		Ø F		Ø G		Ø H		I		L	
		mm	inch	mm	inch	mm	inch	mm	inch	mm	inch	mm	inch	mm	inch	mm	inch	mm	inch	mm	inch
FB 75	1-2-10-19-20	100	3.94	73,5	2.89	40	1.57	20	0.79	15	0.59	18	0.71	9	0.35	11	0.43	14	0.55	12	0.47
FB 95	1-2-10-19-20	120	4.72	92	3.62	60	2.36	20	0.79	15	0.59	20	0.79	9	0.35	13,5	0.53	14	0.55	13	0.51
FB 120	1-2-10-19-20	140	5.51	109,5	4.31	80	3.15	20	0.79	18	0.71	20	0.79	11	0.43	13,5	0.53	15	0.59	13	0.51
FB 150	1-2-10-20	190	7.48	138	5.43	100	3.94	25	0.98	18	0.71	26	1.02	11	0.43	17,5	0.69	15	0.59	17	0.67
FB 195	1-2-10-20	210	8.27	170	6.69	120	4.72	25	0.98	20	0.79	26	1.02	13,5	0.53	17,5	0.69	13	0.51	17	0.67