

LIFTING BRACKET WITH ROPE SAFETY STOP TRAGZAPFEN MIT SEILSICHERUNG STAFFA DI SOLLEVAMENTO CON SICUREZZA FERMAFUNI

Patent-Nr.: TO2003A000468

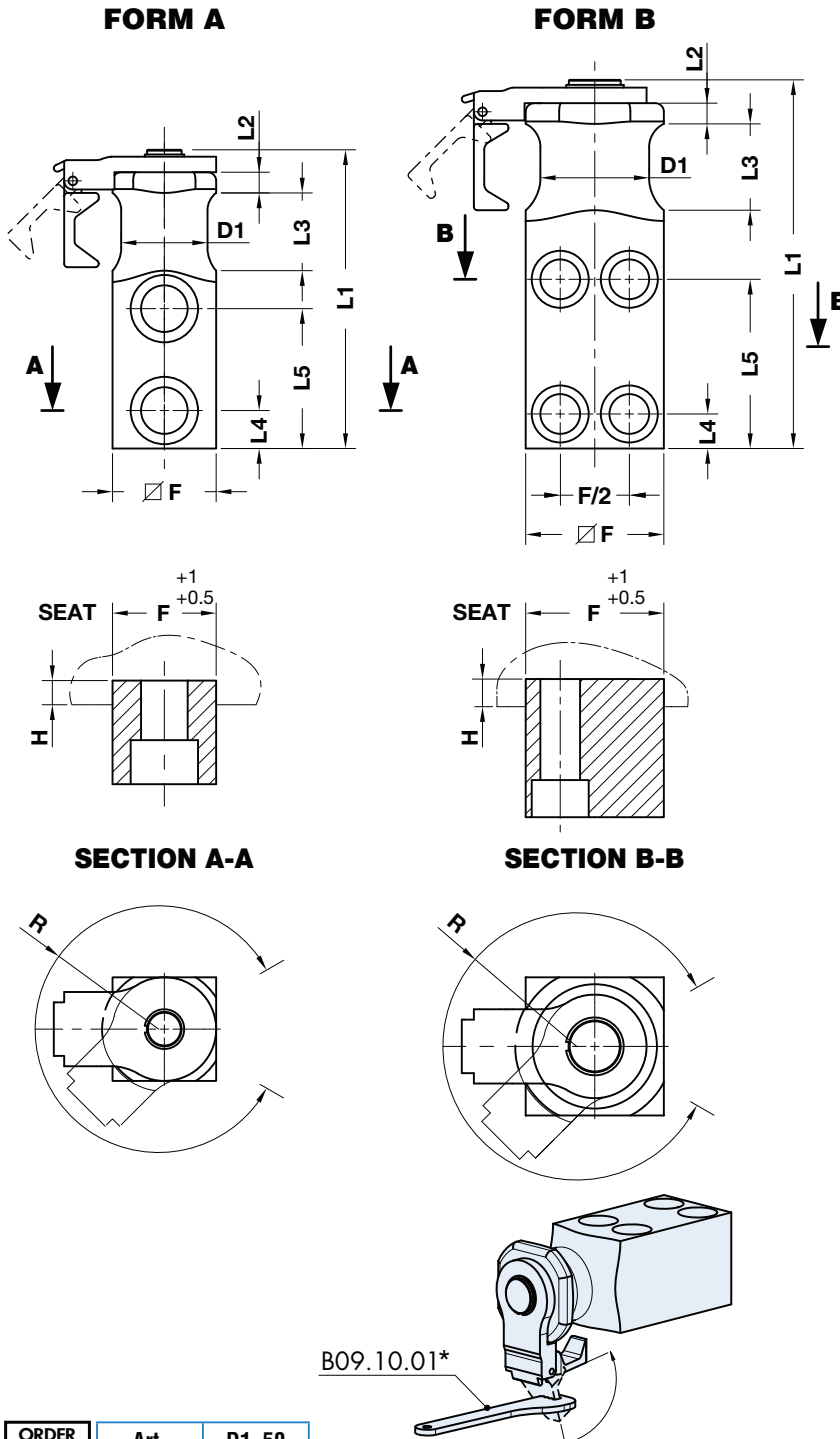

Respect the max load
Maximale Nutzlast beachten
Rispettare il carico Max

Screw the brackets on steel
(minimum quality Fe510 - S355)
Die Tragwangen auf Stahl
(mit Mindestqualität Fe510 - S355 verschrauben)
Avvitare le staffe su acciaio
(qualità minima Fe510 - S355)

WARNING - ACHTUNG - ATTENZIONE:

For safety reason, please consider always that the weight of the die has to be supported by just 2 lifting brackets.

Aus Sicherheitsgründen stets berücksichtigen, dass zwei Tragzapfens das gesamte Werkzeuggewicht tragen müssen.

Per ragioni di sicurezza, considerare sempre che il peso dello stampo deve essere sopportato da 2 sole staffe.

Notes

Material: CK45 - 700÷800 N/mm²
Screws not included

ORDER EXAMPLE	Art.	D1=50
	B01.11.	50

*To open rope stop safety use key B09.10.01

OMCR CODE	Max load (kg)	Max die weight (kg)	D1	L1	L2	L3	L4	L5	F	H	R	FORM	Screws DIN 912 - 8.8
B01.11.20	630	1260	20	99	8	25	10	47	25	8	38	A	M10x30
B01.11.25	1250	2500	25	112,5	8	30	12	50	35	10	42	A	M12x40
B01.11.32	2000	4000	32	132,5	10	32	16	62	40	10	52	A	M16x45
B01.11.40	3200	6400	40	152,5	10	40	18	72	50	12	60	A	M20x60
B01.11.50	5000	10000	50	173	12	45	22	81	60	14	66	A	M24x70
B01.11.63	8000	16000	63	213,5	12	50	20	98	80	16	80	B	M20x90