

CONTROL PANEL CP02A / CP08A / CP11A

(Ford, MABEC, Nissan, Renault and GM North America die Standard)



IT

Pannello di controllo secondo standard Ford e GM Nord America. Base in alluminio provvista di manometro, valvola di caricamento e scaricamento, adattatore 9/16-18 UNF ORFS, tappo di rottura sovrappressione e protezione in acciaio. 3 uscite G1/8" per gestione sistemi collegati.

EN

Control panel according to Ford and GM North America standards. Made up of aluminium base. Gauge, charging and discharging valve, 9/16-18 UNF ORFS adapter, over pressure rupture plug and steel protection. 3 ports G1/8".

DE

Kontrollarmatur gem. Ford und GM North America Normen. Mit Aluminiumgehäuse, Manometer, Auffüll- und Ablassventil, 9/16-18 UNF ORFS Adapter, Überdruck-Bruchstecker und Stahlabdeckung. 3 G1/8" Anschlüsse.

FR

Panneau de contrôle selon les standards Ford et GM, Amérique du Nord, base en aluminium. Manomètre, valve de chargement et déchargement, adaptateur 9/16-18 UNF ORFS, Bouchon de rupture de surpression et protection acier, 3 ports G1/8".

ES

Panel de control según standard Ford y GM Norte América. Base de aluminio con manómetro, válvula de carga y descarga, adaptador 9/16-18 UNF ORFS, tapón de rotura por sobrepresión y protección en acero. 3 salidas G1/8" para gestión sistemas de cilindros conectados.

PT

Painel de controlo de acordo com os Standards Ford e GM América do Norte. Fabricado a partir de uma base de alumínio, manómetro, válvula de carga e descarga, adaptador ORFS 9/16-18 UNF, Plugue ruptura sobrepresão e protecção em aço. 3 saídas G1/8" para sistemas de gestão relacionados.

code	Pressure Gauge	Rupture Plug	Easy Manifold	Gauge Angle Position ↻	
				0°*	180°
39CP02A-...	bar/psi	✓	✗	-	180
39CP08A-...	bar/MPa	✓	✗	-	180
39CP11A-...	bar/psi	✗	✗	-	180

*Visible in the drawing

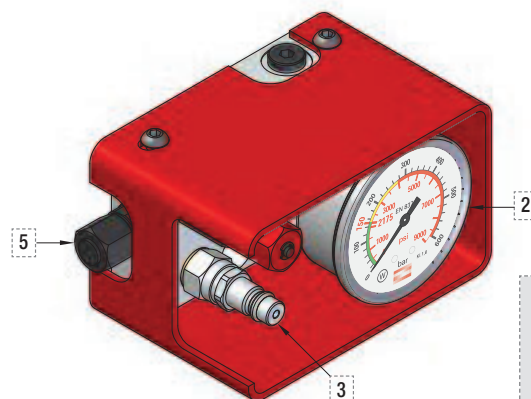
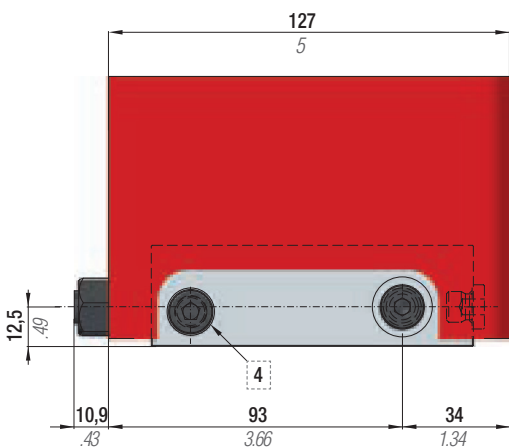
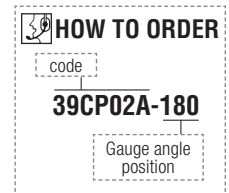
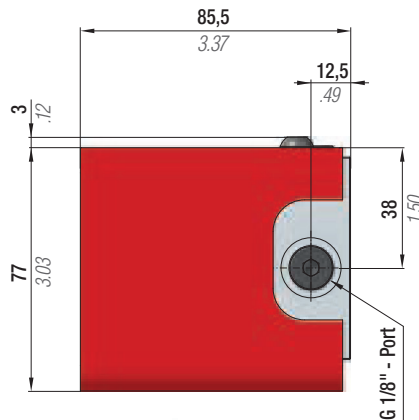
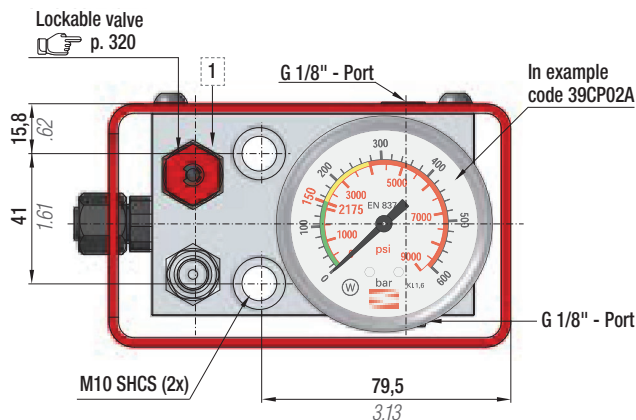

1 Valvola di scarico
Discharging valve
Auslaßventil
Valve de déchargement
Válvula de descarga
Válvula de descarga

2 Manometro 0÷ 620 bar Pressure gauge 0÷ 620 bar Manometer 0÷ 620 bar Manomètre 0÷ 620 bar Manómetro 0÷ 620 bar	3 Innesto rapido di caricamento Cejn Quick coupling for charging Cejn Steckkegel Cejn Accouplement rapide mâle Cejn Acoplamiento rápido para carga Cejn União rápida para carregamento Cejn	4 Tappo di rottura sovrappressione Over pressure rupture plug Überdruck-Bruchstecker Bouchon de rupture de surpression Tapón de rotura por sobrepresión Plugue ruptura sobrepresão	5 Adattatore tenuta frontale 9/16-18 UNF O-Ring Face Seal Adapter 9/16-18 UNF O-ring-Dichtung Adapter 9/16-18 UNF Joint torique adaptateur 9/16-18 UNF O-ring face seal adapter 9/16-18 UNF Adaptador de vedação frontal 9/16-18 UNF
---	--	---	---