

SINTERED STEEL WEAR PLATE
GLEITPLATTE STAHL MIT SINTERGLEITFLÄCHE
PIASTRA GUIDA IN ACCIAIO SINTERIZZATO

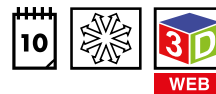
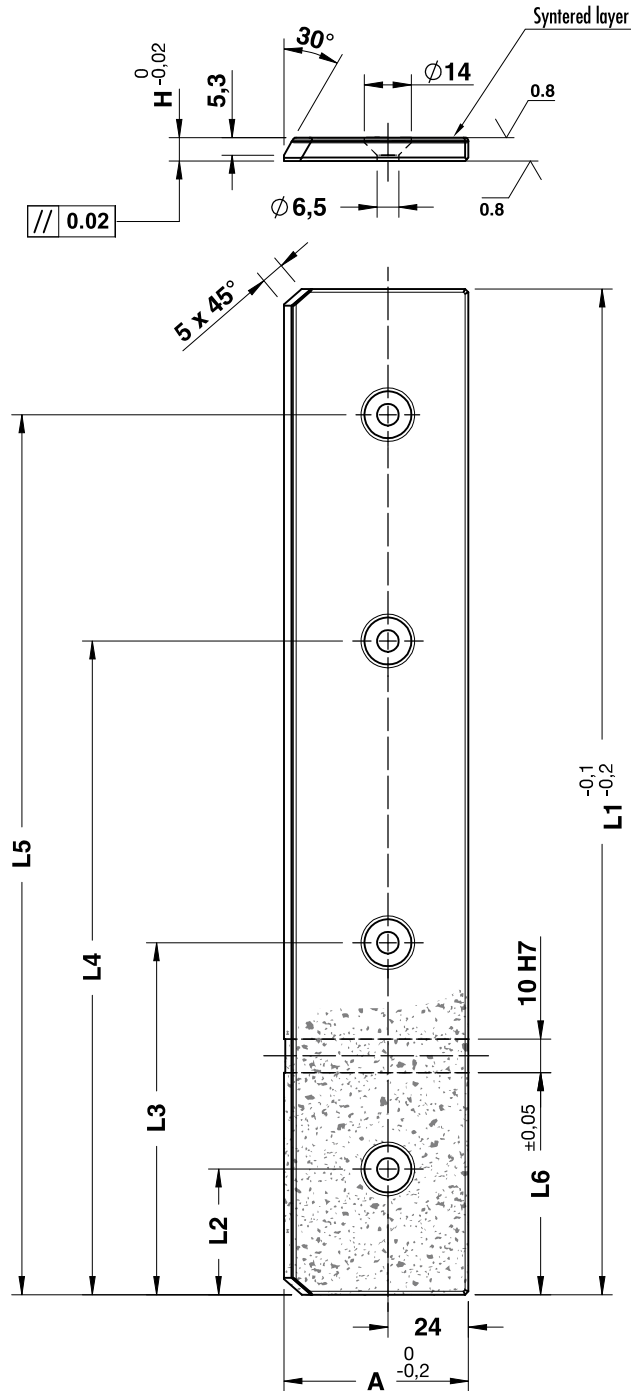

Notes

Material: Steel + SINT300®

Application example

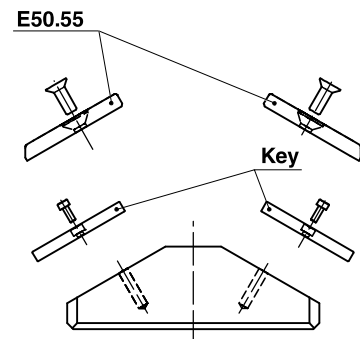

ORDER EXAMPLE	Art.	A=30	H=7	L1=200
	E50.55	030	07	200

OMCR CODE	A	H	L1	L2	L3	L4	L5	L6
E50.55.05507150	55	7	150	18,5	75	131,5	-	36
E50.55.05507200	55	7	200	30,5	100	169,5	-	70
E50.55.05507250	55	7	250	35	90	160	215	70
E50.55.05507300	55	7	300	37,5	105	195	262,5	66,25