

**SINTERED STEEL WEAR PLATE**  
**GLEITPLATTE STAHL MIT SINTERGLEITFLÄCHE**  
**PIASTRA GUIDA IN ACCIAIO SINTERIZZATO**

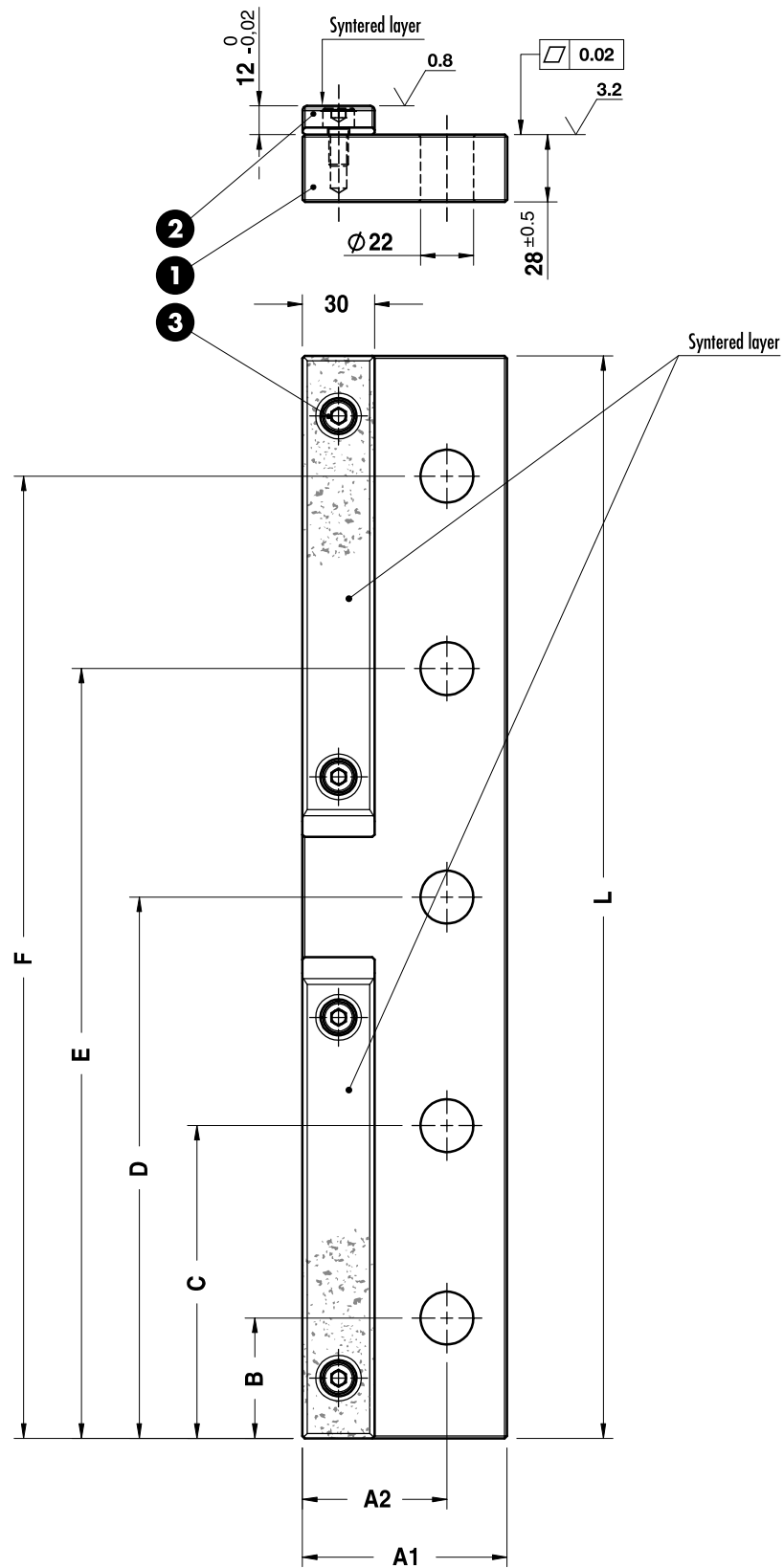

Notes

- 1 **Material:** CK45
- 2 E50.06.
- 3 DIN 912 M8x16

Application example

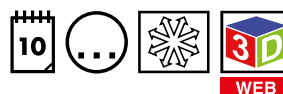
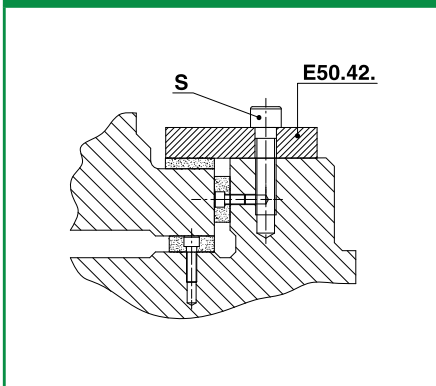

Art.	A1=85	L=200
E50.42.	085	200

OMCR CODE	A1	L	A2	B	C	D	E	F	S
E50.42.085160	85	160	60	45	115	-	-	-	Nr2 - M20x60
E50.42.085200	85	200	60	45	155	-	-	-	Nr2 - M20x60
E50.42.085250	85	250	60	45	125	205	-	-	Nr3 - M20x60
E50.42.085300	85	300	60	45	150	255	-	-	Nr3 - M20x60
E50.42.085350	85	350	60	45	175	305	-	-	Nr3 - M20x60
E50.42.085400	85	400	60	45	125	200	275	355	Nr5 - M20x60
E50.42.085450	85	450	60	50	130	225	320	400	Nr5 - M20x60
E50.42.085500	85	500	60	50	130	250	370	450	Nr5 - M20x60
E50.42.125160	125	160	75	45	115	-	-	-	Nr2 - M20x60
E50.42.125200	125	200	75	45	155	-	-	-	Nr2 - M20x60
E50.42.125250	125	250	75	45	125	205	-	-	Nr3 - M20x60
E50.42.125300	125	300	75	45	150	255	-	-	Nr3 - M20x60
E50.42.125350	125	350	75	45	175	305	-	-	Nr3 - M20x60
E50.42.125400	125	400	75	45	125	200	275	355	Nr5 - M20x60
E50.42.125450	125	450	75	50	130	225	320	400	Nr5 - M20x60
E50.42.125500	125	500	75	50	130	250	370	450	Nr5 - M20x60

Sliding Elements