

GUIDE POST ENDWISE BOLT-ON TYPE
FÜHRUNGSSÄULE ZUM ANSCHRAUBEN
COLONNA DA AVVITARE

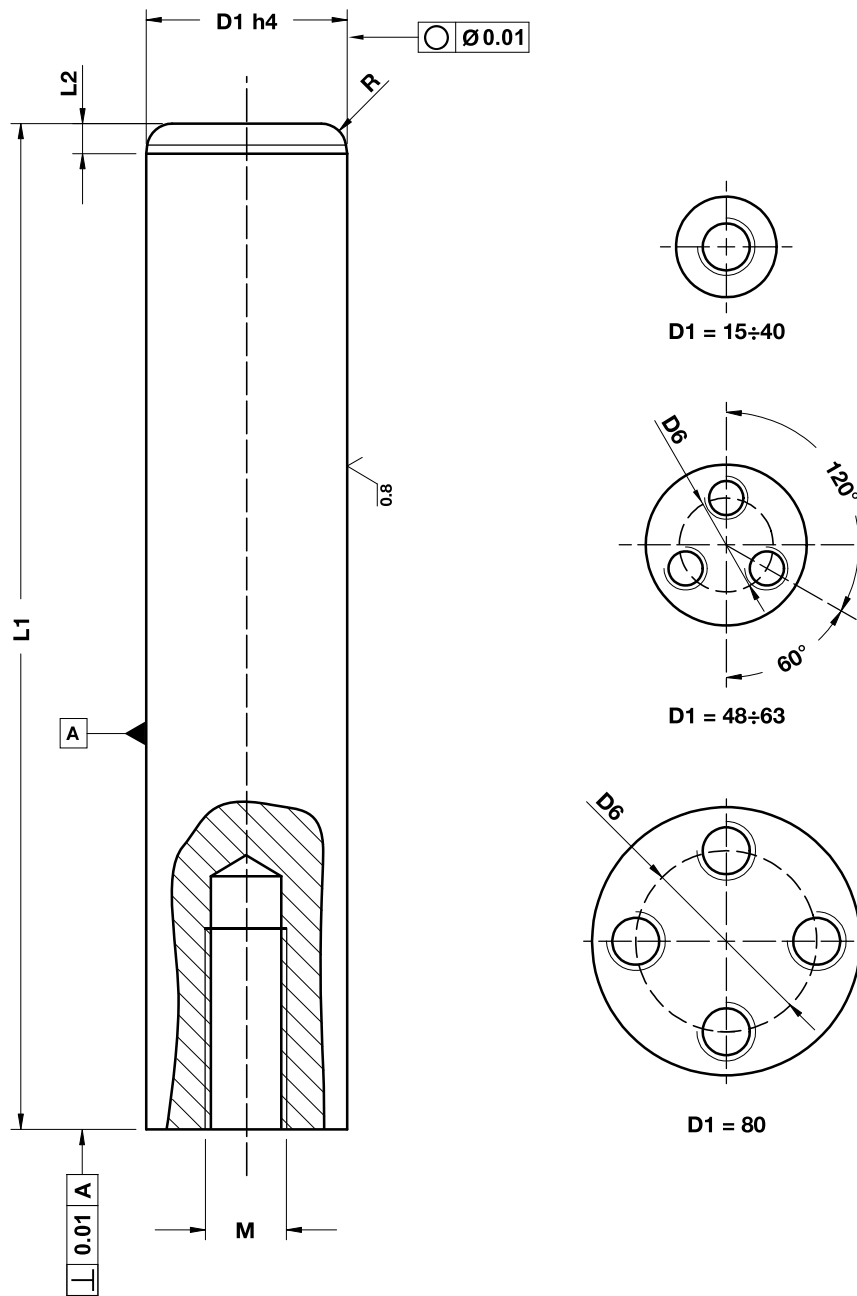

Notes

Material: 16MnCr5
HRC: 60÷62

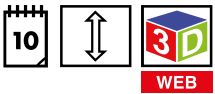
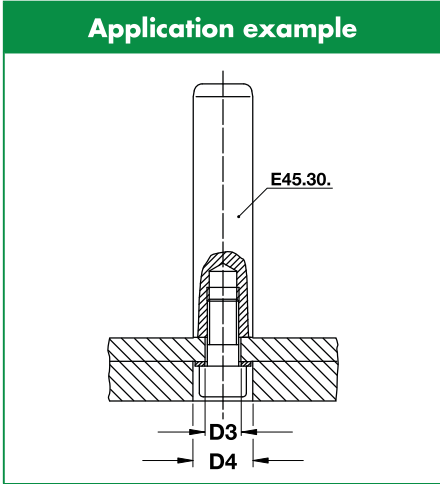

	Art.	D1=16	L1=100
	E45.30.	016	100

*Screws tightening torque
 Anziehdrehmoment
 Coppie di serraggio delle viti

D1	15	16	19	20	24	25	30	32	38	40	48	50	60	63	80
D3	9	9	11	11	14	14	18	18	18	18	14	14	18	18	18
D4	17	17	20	20	22	22	28	28	28	28	22	22	28	28	28
D6	-	-	-	-	-	-	-	-	-	-	28	28	34	34	54
L2	4	4	4	4	6	6	6	6	6	6	8	8	8	8	8
M	8	8	10	10	12	12	16	16	16	16	12	12	16	16	16
R	3	3	3	3	5	5	5	5	5	5	7	7	7	7	7
Screws DIN 912 - 8.8	M8x35		M10x40		M12x40		M16x40				3x M12x50		3x M16x60		4x M16x60
Nm*	21	21	37	37	85	85	150	150	150	150	85	85	200	200	200

L1	15	16	19	20	24	25	30	32	38	40	48	50	60	63	80
90	•	•													
100	•	•	•	•	•	•									
112	•	•	•	•	•	•									
125	•	•	•	•	•	•	•	•							
140	•	•	•	•	•	•	•	•							
160	•	•	•	•	•	•	•	•	•	•					
180	•	•	•	•	•	•	•	•	•	•	•	•			
200	•	•	•	•	•	•	•	•	•	•	•	•	•		
224	•	•	•	•	•	•	•	•	•	•	•	•	•		
250	•	•	•	•	•	•	•	•	•	•	•	•	•	•	
280	•	•	•	•	•	•	•	•	•	•	•	•	•	•	•
315	•	•	•	•	•	•	•	•	•	•	•	•	•	•	•
355	•	•	•	•	•	•	•	•	•	•	•	•	•	•	•
400			•	•	•	•	•	•	•	•	•	•	•	•	•
450					•	•	•	•	•	•	•	•	•	•	•
500					•	•	•	•	•	•	•	•	•	•	•
550									•	•	•	•	•	•	•
600									•	•	•	•	•	•	•
700									•	•	•	•	•	•	•
800									•	•	•	•	•	•	•

Sliding Elements