

GUIDE POST NAAMS
FÜHRUNGSSÄULE NAAMS
COLONNA NAAMS

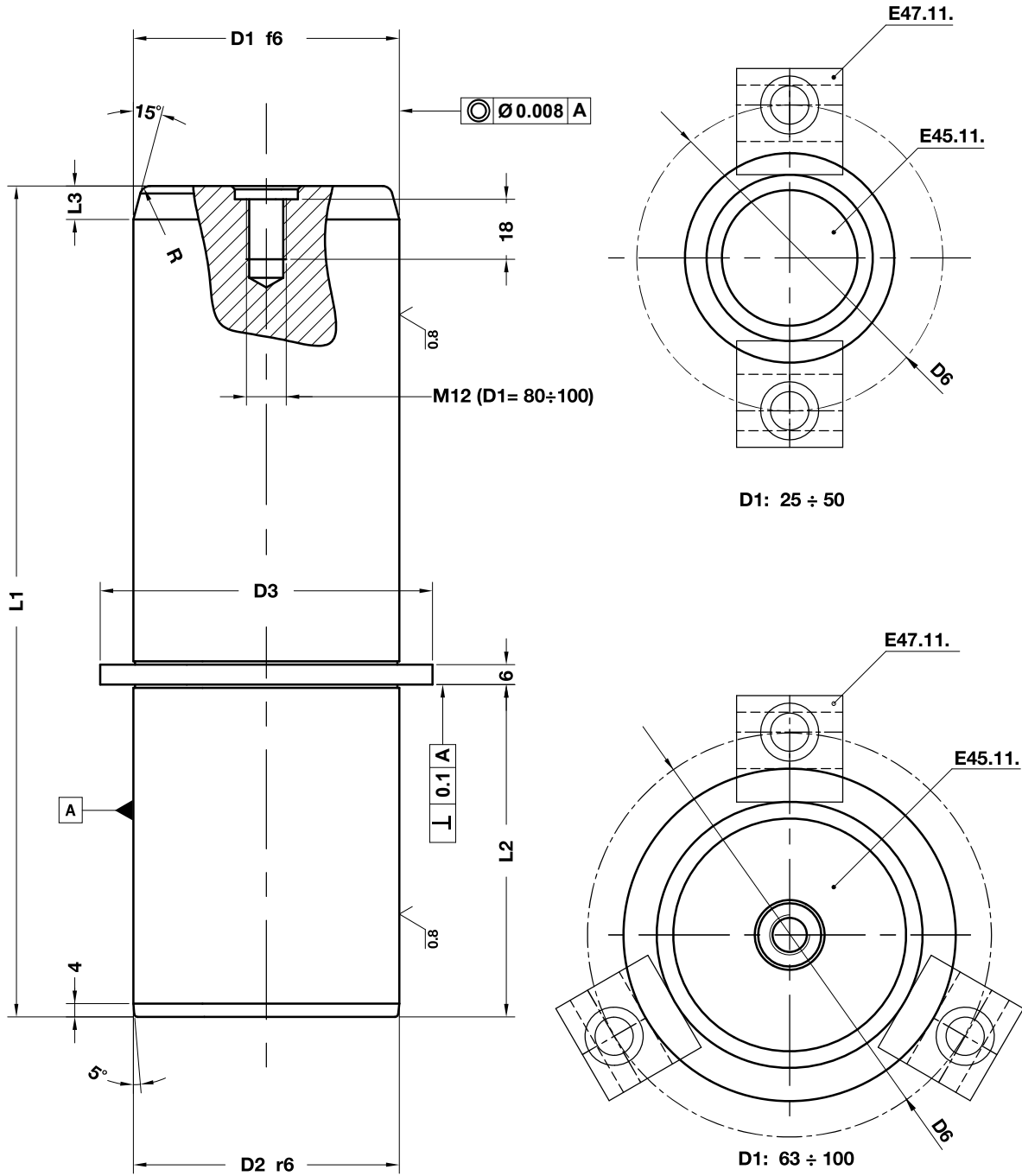

Notes

Material: 16MnCr5
HRC: 60÷62

Application example

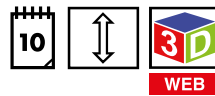
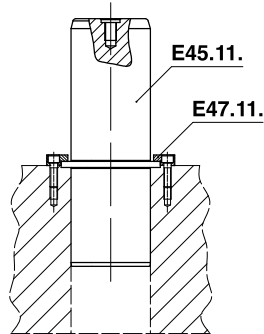

Art.	D1=80	L1=280
E45.11.	080	280

D1	25	32	40	50	63	80	100
D2	25	32	40	50	63	80	100
D3	33	40	50	60	80	90	110
D6	68	75	83	93	106	123	143
L2	40	45	56	70	80	100	125
L3	4	8	8	10	10	10	10
R	2	2	2	2,5	2,5	3	3

L1							
140	•	•					
160	•	•	•	•			
180	•	•	•	•			
200		•	•	•	•		
224			•	•	•		
250			•	•	•	•	
280				•	•	•	
315				•	•	•	•
355					•	•	•
400					•	•	•
500						•	•