

**WEAR PLATE SELF-LUBRICATING
GLEITPLATTE BRONZE MIT FESTSCHMIERSTOFF
PIASTRA GUIDA AUTOLUBRIFICANTE**

Notes

Material: Bronze + Graphite
HB > 190

Application example

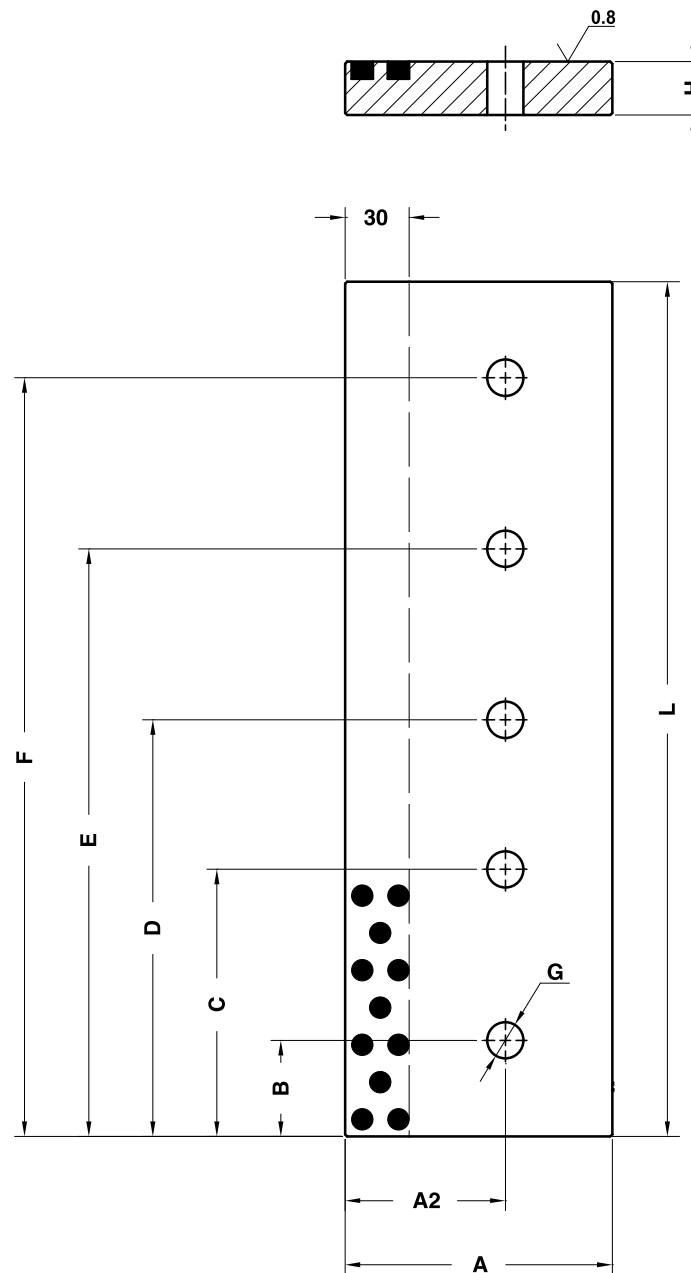
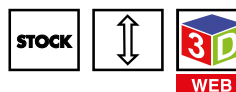
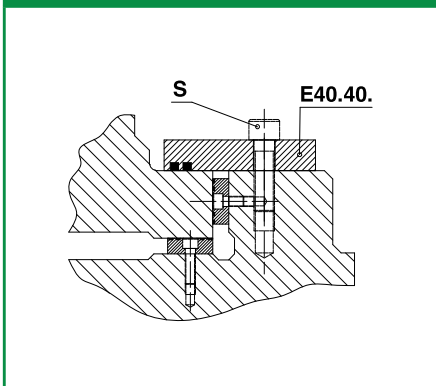

	Art.	A=85	H=30	L=200
	E40.40.	085	30	200

OMCR CODE	A	A2	L	H	B	C	D	E	F	G	S
E40.40.08530160	85	60	160	30	45	-	-	-	115	21	Nr.2 - M20x70
E40.40.08530200	85	60	200	30	45	-	-	-	155	21	Nr.2 - M20x70
E40.40.08530250	85	60	250	30	45	-	125	-	205	21	Nr.3 - M20x70
E40.40.08530300	85	60	300	30	45	-	150	-	255	21	Nr.3 - M20x70
E40.40.08530350	85	60	350	30	45	-	175	-	305	21	Nr.3 - M20x70
E40.40.08530400	85	60	400	30	45	125	200	275	355	21	Nr.5 - M20x70
E40.40.12525160	125	75	160	25	45	-	-	-	115	17	Nr.2 - M16x60
E40.40.12525200	125	75	200	25	45	-	-	-	155	17	Nr.2 - M16x60
E40.40.12525250	125	75	250	25	45	-	125	-	205	17	Nr.3 - M16x60
E40.40.12525400	125	75	400	25	45	125	200	275	355	17	Nr.5 - M16x60
E40.40.12530160	125	75	160	30	45	-	-	-	115	21	Nr.2 - M20x70
E40.40.12530200	125	75	200	30	45	-	-	-	155	21	Nr.2 - M20x70
E40.40.12530250	125	75	250	30	45	-	125	-	205	21	Nr.3 - M20x70
E40.40.12530300	125	75	300	30	45	-	150	-	255	21	Nr.3 - M20x70
E40.40.12530350	125	75	350	30	45	-	175	-	305	21	Nr.3 - M20x70
E40.40.12530400	125	75	400	30	45	125	200	275	355	21	Nr.5 - M20x70
E40.40.12530450	125	75	450	30	50	130	225	320	400	21	Nr.5 - M20x70
E40.40.12530500	125	75	500	30	50	130	250	370	450	21	Nr.5 - M20x70

Sliding Elements