

## WEAR PLATE STEEL GLEITPLATTE STAHL PIASTRA GUIDA IN ACCIAIO

### Notes

**Material:** 16MnCr5  
**HRC:** 58÷60

STOCK

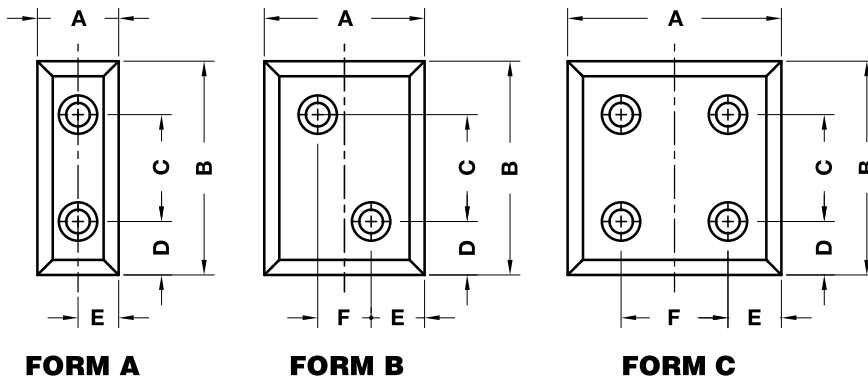

**FORM A**

**FORM B**

**FORM C**

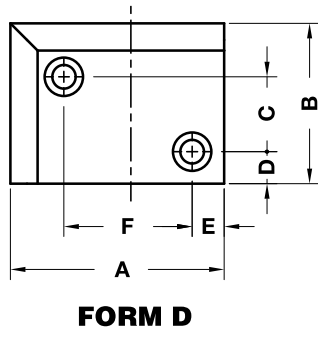

**FORM D**

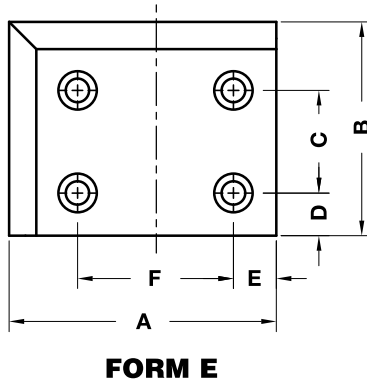

**FORM E**

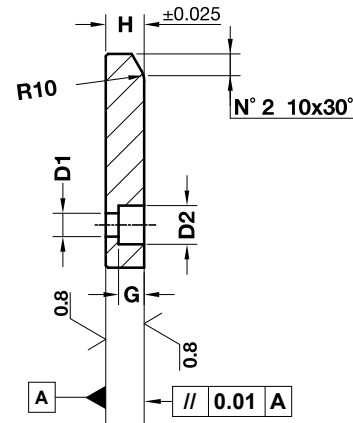
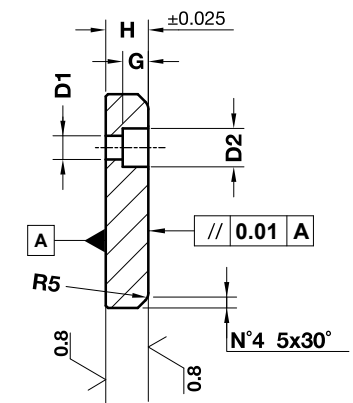

ORDER EXAMPLE	Art.	A=75	H=20	B=100
	E40.11.	075	20	100

OMCR CODE	A	B	C	D	D1	D2	E	F	G	H	Form
E40.11.03820100	38	100	50	25	11	18	19	-	12	20	A
E40.11.03820150	38	150	100	25	11	18	19	-	12	20	A
E40.11.07520100	75	100	50	25	11	18	25	25	12	20	B
E40.11.07520150	75	150	100	25	11	18	37,5	-	12	20	A
E40.11.10020100	100	100	50	25	11	18	25	50	12	20	C
E40.11.10020150	100	150	100	25	11	18	25	50	12	20	C
E40.11.10018075	100	75	35	15	11	18	15	60	12	18	D
E40.11.12525100	125	100	48	20	13	20	20	73	14	25	E
E40.11.15025125	150	125	68	25	13	20	25	93	14	25	E

Sliding Elements