

**WEAR PLATE STEEL VDI 3357**  
**GLEITPLATTE STAHL VDI 3357**  
**PIASTRA GUIDA IN ACCIAIO VDI 3357**

**FORM A**

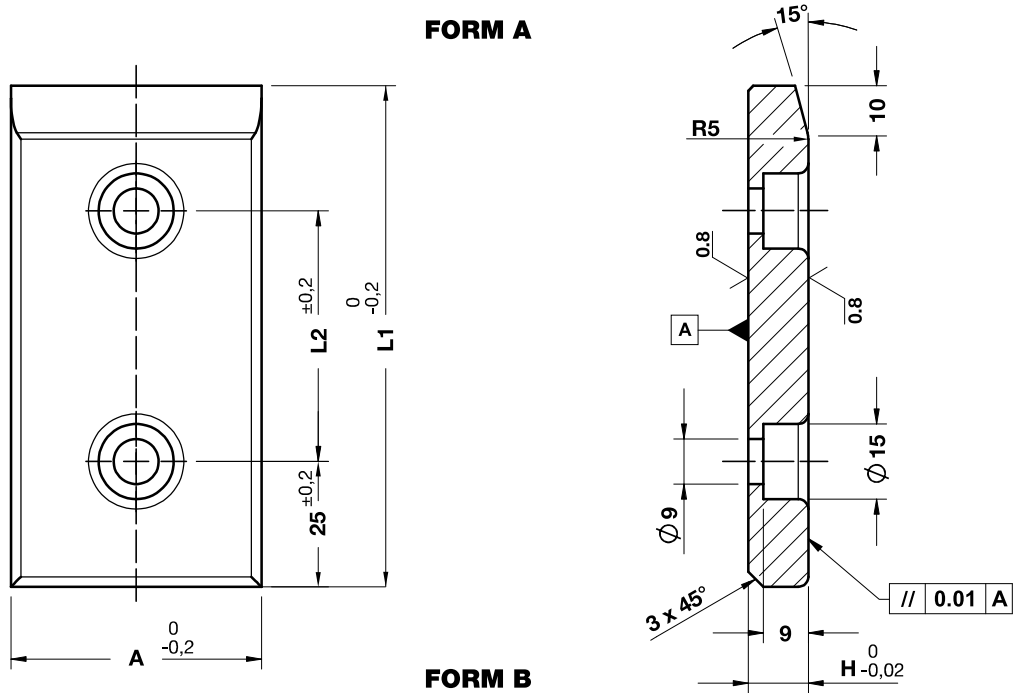

**FORM B**

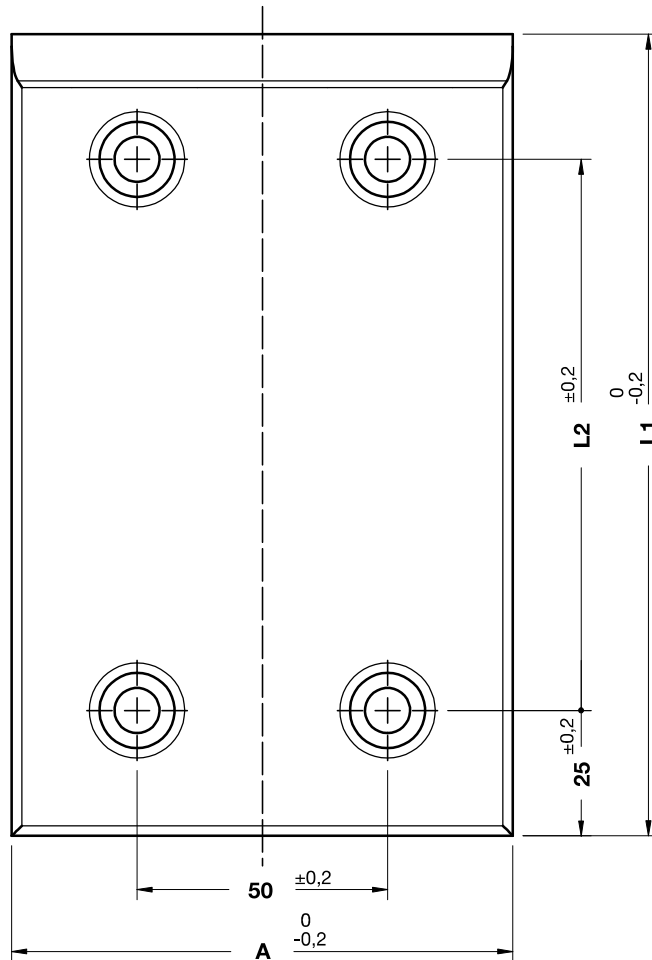

Notes

**Material:** 16MnCr5  
**HRC:** 58÷60

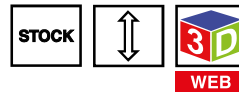

	Art.	A=50	H=12	L1=100
	E40.07.	050	12	100

OMCR CODE	A	H	L1	L2	FORM
E40.07.03012080	30	12	80	30	A
E40.07.03012100	30	12	100	50	A
E40.07.03012125	30	12	125	75	A
E40.07.03012160	30	12	160	110	A
E40.07.03012200	30	12	200	150	A
E40.07.04012080	40	12	80	30	A
E40.07.04012100	40	12	100	50	A
E40.07.04012125	40	12	125	75	A
E40.07.04012160	40	12	160	110	A
E40.07.04012200	40	12	200	150	A
E40.07.05012080	50	12	80	30	A
E40.07.05012100	50	12	100	50	A
E40.07.05012125	50	12	125	75	A
E40.07.05012160	50	12	160	110	A
E40.07.05012180	50	12	180	130	A
E40.07.05012200	50	12	200	150	A
E40.07.06012080	60	12	80	30	A
E40.07.06012100	60	12	100	50	A
E40.07.06012125	60	12	125	75	A
E40.07.06012160	60	12	160	110	A
E40.07.06012180	60	12	180	130	A
E40.07.06012200	60	12	200	150	A
E40.07.08012080	80	12	80	30	A
E40.07.08012100	80	12	100	50	A
E40.07.08012125	80	12	125	75	A
E40.07.08012160	80	12	160	110	A
E40.07.08012200	80	12	200	150	A
E40.07.10012125	100	12	125	75	B
E40.07.10012160	100	12	160	110	B
E40.07.10012200	100	12	200	150	B
E40.07.10012225	100	12	225	175	B
E40.07.10012250	100	12	250	200	B