

ISO 11901 - 1	VDI 3003	B2 4006 (BMW)	075.90.55 (FCA)
W-DX35-6203 (Ford)	PG23D (Mazda)	B8 3180 220 000 001(MB)	E24.54.815.G (PSA)
EM24.54.700 (Renault)	39D 878 (VW)		

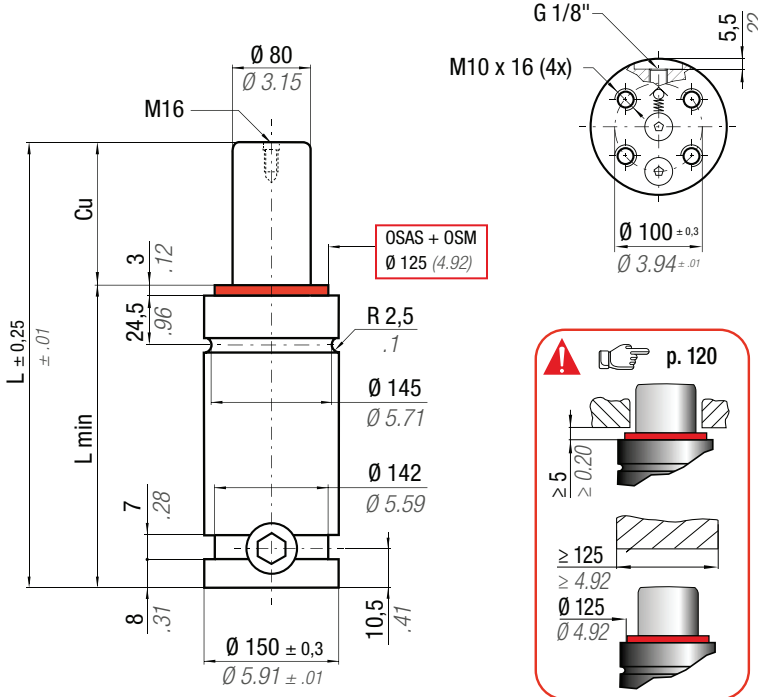

OSAS + OSM = OVER STROKE SAFETY + OVER STROKE MARKER



Il nuovo codice sarà fornito solo ad esaurimento del vecchio
The new code will be supplied only when the old will be out of stock

ACTIVE SAFETY



Der neue Kode wird nur angegeben, wenn der alte nicht mehr lieferbar ist

OSAS

Le nouveau code sera fourni uniquement lorsque le vieux stock sera épuisé



El nuevo código será suministrado sólo cuando se agoten las existencias del antiguo

USAS

O novo código irá ser fornecido apenas quando o antigo esgotar stock

easu MANIFOLD p. 247



OPAS

* F_{1i} = Isothermal end force at 100% Cu p. 16
** F_{1p} = Polyphropic end force at 100% Cu

N ₂	0 - 80 °C 32 - 176 °F	ΔP ± 0,33 %/°C	P max 150 bar 2175 psi	P min 20 bar 290 psi	S 50,27 cm ² 7.792 in ²	SPM ~ 15 - 50 (at 20°C)	Max Speed 1,8 m/s	Maintenance kit 39BMSCO7500D Cu 25 ÷ 80 39BMSCO7500DH Cu 88 ÷ 300
----------------	--------------------------	---------------------------	-------------------------------------	-----------------------------------	--	--------------------------------------	-----------------------------	--

CODE PHASING OUT from 04/2021	NEW	Cu		L		L min		F ₀ Initial force		F _{1i} * End force *		F _{1p} ** End force **		V ₀		2014/68/EU		
		mm	inch	mm	inch	mm	inch	daN	lb	daN	lb	daN	lb	cm ³	in ³		~Kg	~lb
SC 7500 - 025 - D	SC 7500 - 025 - E	25	0.98	205	8.07	180	7.09	7540	16950	9357	21035	10511	23630	757	46.22	18,71	41.25	✓
SC 7500 - 038 - D	SC 7500 - 038 - E	38	1.50	231	9.09	193	7.60			9845	22132	11246	25282	951	58.05	19,50	42.99	✓
SC 7500 - 050 - D	SC 7500 - 050 - E	50	1.97	255	10.04	205	8.07			10171	22866	11743	26400	1130	68.96	20,24	44.62	✓
SC 7500 - 063 - D	SC 7500 - 063 - E	63,5	2.50	282	11.10	218,5	8.60			10448	23488	12170	27359	1331	81.23	21,06	46.43	✓
SC 7500 - 075 - D	SC 7500 - 075 - E	75	2.95	305	12.10	230	9.06			10633	23904	12456	28003	1503	91.69	21,76	47.97	✓
SC 7500 - 080 - D	SC 7500 - 080 - E	80	3.15	315	12.40	235	9.25			10702	24060	12564	28246	1577	96.24	22,07	48.66	✓
SC 7500 - 088 - D	SC 7500 - 088 - E	87,5	3.44	330	12.99	242,5	9.55			10822	24329	12751	28666	1689	103.06	22,45	49.49	✓
SC 7500 - 100 - D	SC 7500 - 100 - E	100	3.94	355	13.98	255	10.04			10930	24572	12921	29047	1875	114.43	23,23	51.21	✓
SC 7500 - 113 - D	SC 7500 - 113 - E	113	4.45	380	14.96	267	10.51			11076	24900	13150	29562	2057	125.52	23,98	52.87	✓
SC 7500 - 125 - D	SC 7500 - 125 - E	125	4.92	405	15.94	280	11.02			11138	25039	13248	29782	2248	137.17	24,76	54.59	✓
SC 7500 - 138 - D	SC 7500 - 138 - E	138	5.43	430	16.93	292	11.50	11249	25289	13424	30177	2430	148.26	25,51	56.24	✓		
SC 7500 - 150 - D	SC 7500 - 150 - E	150	5.91	455	17.91	305	12.10	11291	25382	13490	30326	2620	159.91	26,28	57.94	✓		
SC 7500 - 160 - D	SC 7500 - 160 - E	160	6.30	475	18.70	315	12.40	11341	25496	13570	30506	2769	169.00	26,90	59.30	✓		
SC 7500 - 175 - D	SC 7500 - 175 - E	175	6.89	505	19.88	330	12.99	11408	25646	13676	30745	2993	182.64	27,81	61.31	✓		
SC 7500 - 200 - D	SC 7500 - 200 - E	200	7.87	555	21.85	355	13.98	11501	25856	13824	31079	3366	205.38	29,34	64.68	✓		
SC 7500 - 225 - D	SC 7500 - 225 - E	225	8.86	605	23.82	380	14.96	11577	26025	13945	31350	3738	228.12	30,87	68.06	✓		
SC 7500 - 250 - D	SC 7500 - 250 - E	250	9.84	655	25.79	405	15.94	11639	26166	14045	31574	4111	250.85	32,39	71.41	✓		
SC 7500 - 275 - D	SC 7500 - 275 - E	275	10.83	705	27.76	430	16.93	11692	26284	14129	31764	4483	273.59	33,92	74.78	✓		
SC 7500 - 300 - D	SC 7500 - 300 - E	300	11.81	755	29.72	455	17.91	11736	26385	14201	31926	4856	296.33	35,45	78.15	✓		

SC SCF

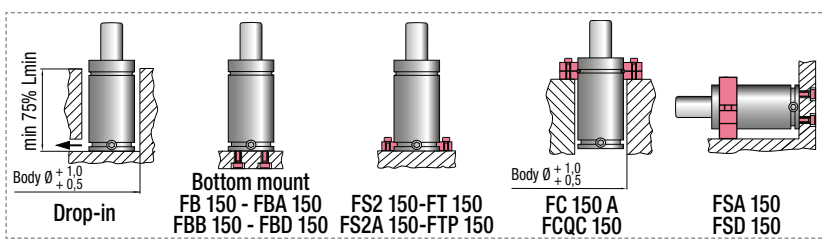

HOW TO ORDER p. 121

INSTALLATION GUIDELINE p. 205