

ISO 11901 - 1	VDI 3003	B2 4006 (BMW)	075.90.55 (FCA)
W-DX35-6203 (Ford)	PG23D (Mazda)	B8 3180 220 000 001(MB)	K 32 S (Nissan)
E24.54.815.G (PSA)	EM24.54.700 (Renault)	SES-K 5404e (Suzuki)	39D 878 (VW)

SC 3000



ACTIVE SAFETY



OSAS



USAS



OPAS

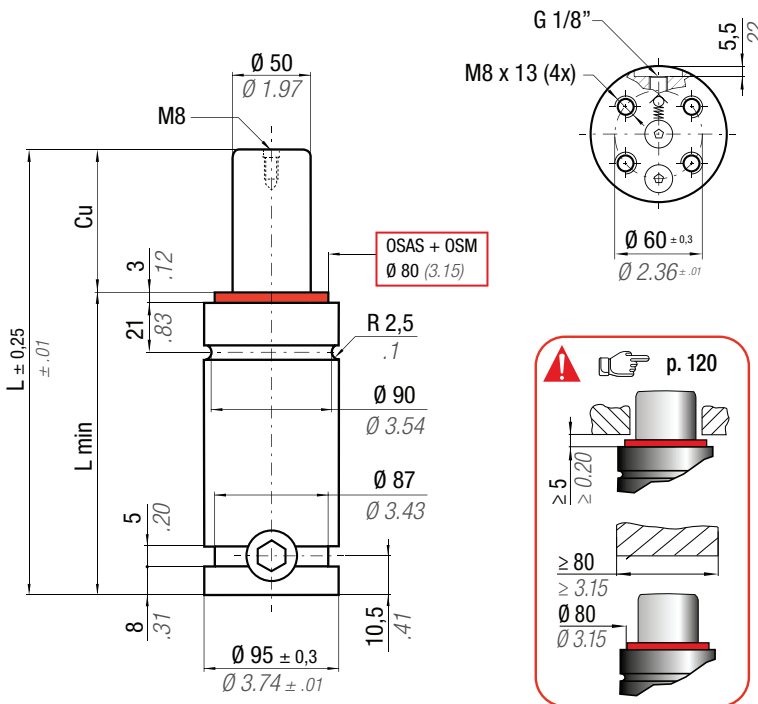

OVER STROKE OVER
OSAS + OSM = ACTIVE SAFETY + STROKE MARKER

Il nuovo codice sarà fornito solo ad esaurimento del vecchio
 The new code will be supplied only when the old will be out of stock
 Der neue Kode wird nur angegeben, wenn der alte nicht mehr lieferbar ist
 Le nouveau code sera fourni uniquement lorsque le vieux stock sera écoulé
 El nuevo código será suministrado sólo cuando se agoten las existencias del antiguo
 O novo código irá ser fornecido apenas quando o antigo esgotar stock

easu MANIFOLD p. 247

* F_{1i} = Isothermal end force at 100% Cu p. 16
 ** F_{1p} = Polyphoric end force at 100% Cu

	0 - 80 °C 32 - 176 °F	ΔP ± 0,33 %/°C	P max 150 bar 2175 psi	P min 20 bar 290 psi	S 19,63 cm ² 3.043 in ²	SPM ~ 15 - 50 (at 20°C)	Max Speed 1,8 m/s	Maintenance kit 39BMSC03000E
--	--------------------------	---------------------------	-------------------------------------	-----------------------------------	--	--------------------------------------	-----------------------------	--

CODE PHASING OUT from 04/2021	NEW	Cu		L		L min		F0 Initial force		F1i * End force *		F1p ** End force **		V0		PED 2014/68/EU		
		mm	inch	mm	inch	mm	inch	daN	lb	daN	lb	daN	lb	cm ³	in ³	~Kg	~lb	✓
SC 3000 - 013 - D	SC 3000 - 013 - E	13	0.51	145	5.71	132	5.20	2945 6621 ± 5%	150 bar 2175 psi	3532	7940	3923	8820	180	11.00	5,57	12.28	✓
SC 3000 - 025 - D	SC 3000 - 025 - E	25	0.98	170	6.69	145	5.71			3802	8547	4327	9726	254	15.51	5,90	13.01	✓
SC 3000 - 038 - D	SC 3000 - 038 - E	38	1.50	196	7.72	158	6.22			3988	8964	4609	10362	332	20.25	6,21	13.69	✓
SC 3000 - 050 - D	SC 3000 - 050 - E	50	1.97	220	8.66	170	6.69			4103	9225	4788	10764	404	24.64	6,50	14.33	✓
SC 3000 - 063 - D	SC 3000 - 063 - E	63,5	2.50	247	9.72	183,5	7.22			4197	9435	4934	11091	484	29.55	6,83	15.06	✓
SC 3000 - 075 - D	SC 3000 - 075 - E	75	2.95	270	10.63	195	7.68			4257	9571	5028	11303	553	33.75	7,10	15.65	✓
SC 3000 - 080 - D	SC 3000 - 080 - E	80	3.15	280	11.02	200	7.87			4279	9620	5062	11381	583	35.58	7,22	15.92	✓
SC 3000 - 088 - D	SC 3000 - 088 - E	87,5	3.44	295	11.61	207,5	8.17			4320	9712	5126	11525	628	38.31	7,41	16.34	✓
SC 3000 - 100 - D	SC 3000 - 100 - E	100	3.94	320	12.60	220	8.66			4350	9780	5175	11633	703	42.87	7,67	16.91	✓
SC 3000 - 113 - D	SC 3000 - 113 - E	113	4.45	345	13.58	232	9.13			4394	9878	5243	11787	777	47.43	7,97	17.57	✓
SC 3000 - 125 - D	SC 3000 - 125 - E	125	4.92	370	14.57	245	9.65	4412	9917	5271	11850	853	52.02	8,27	18.23	✓		
SC 3000 - 138 - D	SC 3000 - 138 - E	138	5.43	395	15.55	257	10.12	4444	9990	5322	11965	927	56.59	8,57	18.89	✓		
SC 3000 - 150 - D	SC 3000 - 150 - E	150	5.91	420	16.54	270	10.63	4457	10019	5343	12011	1002	61.15	8,87	19.56	✓		
SC 3000 - 160 - D	SC 3000 - 160 - E	160	6.30	440	17.32	280	11.02	4471	10052	5366	12064	1062	64.79	9,11	20.08	✓		
SC 3000 - 175 - D	SC 3000 - 175 - E	175	6.89	470	18.50	295	11.61	4491	10095	5397	12133	1151	70.26	9,47	20.88	✓		
SC 3000 - 200 - D	SC 3000 - 200 - E	200	7.87	520	20.47	320	12.60	4517	10155	5439	12228	1301	79.38	10,08	22.22	✓		
SC 3000 - 225 - D	SC 3000 - 225 - E	225	8.86	570	22.44	345	13.58	4538	10202	5473	12304	1450	88.50	10,68	23.55	✓		
SC 3000 - 250 - D	SC 3000 - 250 - E	250	9.84	620	24.41	370	14.57	4556	10241	5501	12367	1600	97.62	11,28	24.87	✓		
SC 3000 - 275 - D	SC 3000 - 275 - E	275	10.83	670	26.38	395	15.55	4570	10274	5524	12419	1749	106.74	11,88	26.19	✓		
SC 3000 - 300 - D	SC 3000 - 300 - E	300	11.81	720	28.35	420	16.54	4582	10302	5544	12463	1899	115.85	12,49	27.54	✓		

◆ Disposable

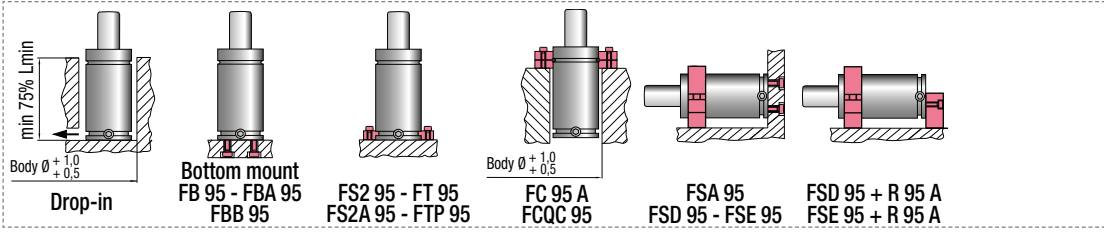

HOW TO ORDER p. 121

INSTALLATION GUIDELINE p. 205