



OSAS + OSM = OVER STROKE ACTIVE SAFETY + OVER STROKE MARKER

ACTIVE SAFETY

Il nuovo codice sarà fornito solo ad esaurimento del vecchio

The new code will be supplied only when the old will be out of stock

Der neue Kode wird nur angegeben, wenn der alte nicht mehr lieferbar ist

Le nouveau code sera fourni uniquement lorsque le vieux stock sera écolé

El nuevo código será suministrado sólo cuando se agoten las existencias del antiguo

O novo código irá ser fornecido apenas quando o antigo esgotar stock



OSAS



USAS



OPAS

* F_{1i} =

Isothermal end force at 100% Cu



p. 16

** F_{1p} =

Polytropic end force at 100% Cu

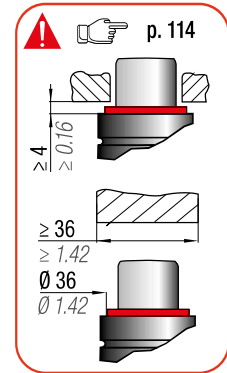
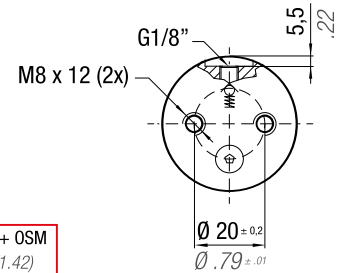
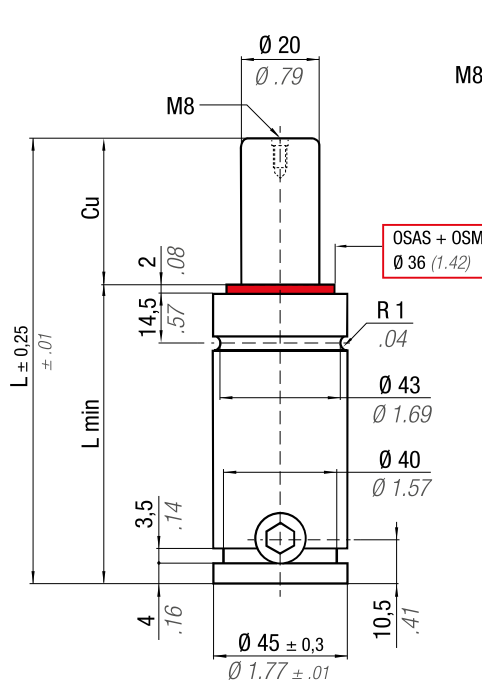

N ₂	0 - 80 °C 32 - 176 °F	ΔP ± 0,33 %/°C	P max 150 bar 2175 psi	P min 20 bar 290 psi	S 3,14 cm ² 0.487 in ²	SPM ~ 40 - 100 (at 20°C)	Max Speed 1,8 m/s	Maintenance kit 39BMS00500B
----------------	--------------------------	---------------------------	------------------------------	----------------------------	--	--------------------------------	----------------------	--------------------------------

CODE PHASING OUT from 04/2021	NEW	Cu		L		L min		F ₀		F _{1i} *		F _{1p} **		V ₀		~Kg	~lb	PED 2014/68/EU
		mm	inch	mm	inch	mm	inch	daN	lb	daN	lb	daN	lb	cm ³	in ³			
S 500 - 006 - A	◆ S 500 - 006 - B	6	0.24	62	2.44	56	2.20	470 1057 ± 5% 150 bar 2175 psi + 20 °C + 68 °F		597	1343	676	1520	10,4	0.63	0,54	1.19	✓
S 500 - 013 - A	◆ S 500 - 013 - B	13	0.51	76	2.99	63	2.48			651	1464	758	1704	17,2	1.05	0,58	1.28	✓
S 500 - 019 - A	S 500 - 019 - B	19	0.75	88	3.46	69	2.72			675	1517	794	1785	22,9	1.40	0,62	1.37	✓
S 500 - 025 - A	S 500 - 025 - B	25	0.98	100	3.94	75	2.95			689	1550	817	1837	28,7	1.75	0,67	1.48	✓
S 500 - 038 - A	S 500 - 038 - B	38	1.50	126	4.96	88	3.46			708	1592	847	1904	41,2	2.51	0,77	1.70	✓
S 500 - 050 - A	S 500 - 050 - B	50	1.97	150	5.91	100	3.94			718	1613	862	1938	52,8	3.22	0,85	1.87	✓
S 500 - 063 - A	S 500 - 063 - B	63	2.48	176	6.93	113	4.45			724	1629	873	1963	65,3	3.98	0,90	1.98	✓
S 500 - 080 - A	S 500 - 080 - B	80	3.15	210	8.27	130	5.12			730	1642	882	1983	81,6	4.98	1,01	2.23	✓
S 500 - 100 - A	S 500 - 100 - B	100	3.94	250	9.84	150	5.91			735	1652	889	2000	100,9	6.16	1,16	2.56	✓
S 500 - 125 - A	S 500 - 125 - B	125	4.92	300	11.81	175	6.89			738	1660	895	2013	124,9	7.62	1,35	2.98	✓

◆ Disposable

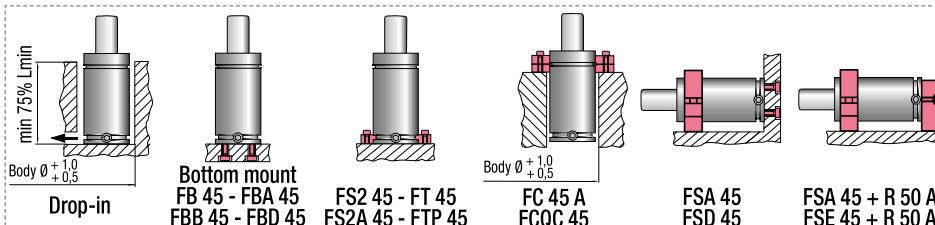

HOW TO ORDER

p. 115

INSTALLATION GUIDELINE

p. 205