

ISO 11901 - 3 W-DX35-6204 (Ford)	VDI 3003 - Blatt 3 PG 24D (Mazda)	B2 4005 (BMW) B8 3180 220 000 004(MB)	075.90.60 (FCA) 39D 997 (VW)
-------------------------------------	--------------------------------------	--	---------------------------------

RV 9500

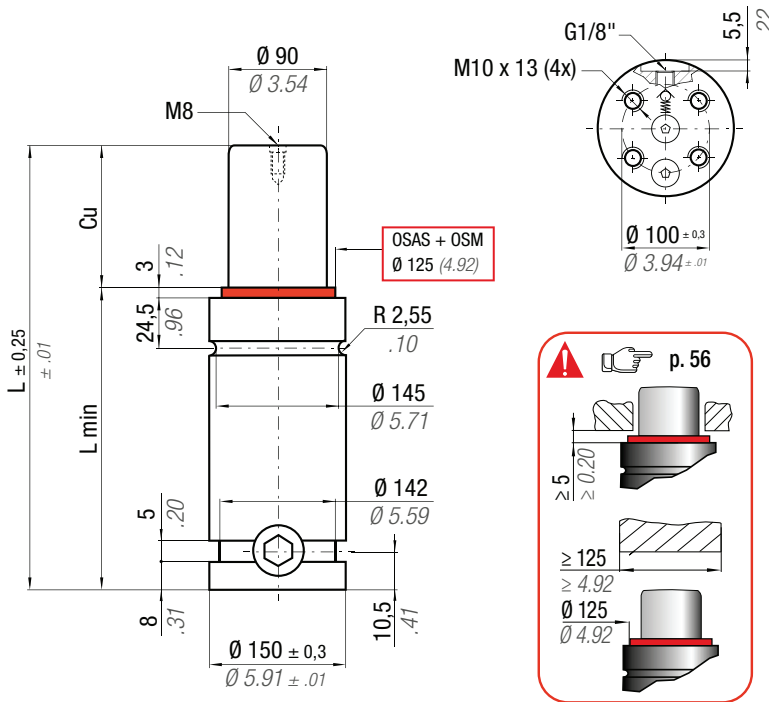

OSAS + OSM = OVER STROKE ACTIVE SAFETY + OVER STROKE MARKER



Il nuovo codice sarà fornito solo ad esaurimento del vecchio

ACTIVE SAFETY

The new code will be supplied only when the old will be out of stock



Der neue Kode wird nur angegeben, wenn der alte nicht mehr lieferbar ist

OSAS

Le nouveau code sera fourni uniquement lorsque le vieux stock sera écoulé



USAS

El nuevo código será suministrado sólo cuando se agoten las existencias del antiguo stock

O novo código irá ser fornecido apenas quando o antigo esgotar stock



OPAS

easu MANIFOLD p. 247

* F_{1i} = Isothermal end force at 100% Cu p. 16
 ** F_{1p} = Polyphropic end force at 100% Cu

RV

N ₂	0 - 80 °C 32 - 176 °F	ΔP ± 0,33 %/°C	P max 150 bar 2175 psi	P min 20 bar 290 psi	S 63,62 cm ² 9.864 in ²	SPM ~ 20 - 80 (at 20°C)	Max Speed 1,8 m/s	Maintenance kit 39BMRV09500C
----------------	--------------------------	---------------------------	-------------------------------------	-----------------------------------	--	--------------------------------------	-----------------------------	--

CODE PHASING OUT from 04/2021	NEW	Cu		L		L min		F ₀ Initial force		F _{1i} * End force *		F _{1p} ** End force **		V ₀		PED 2014/68/EU		
		mm	inch	mm	inch	mm	inch	daN	lb	daN	lb	daN	lb	cm ³	in ³	-Kg	-lb	✓
RV 9500 - 019 - A	◆ RV 9500 - 019 - B	19	0.75	116	4.57	97	3.82	9540 ± 5% 150 bar 2175 psi + 20 °C +68 °F		13135	29528	15265	34318	513	31.31	9,56	21.08	✓
RV 9500 - 025 - A	RV 9500 - 025 - B	25	0.98	128	5.04	103	4.06			13676	30744	16105	36206	609	37.16	9,93	21.89	✓
RV 9500 - 032 - A	RV 9500 - 032 - B	32	1.26	142	5.59	110	4.33			14156	31825	16862	37906	722	44.06	10,37	22.86	✓
RV 9500 - 038 - A	RV 9500 - 038 - B	38	1.50	154	6.06	116	4.57			14480	32553	17376	39062	818	49.92	10,74	23.68	✓
RV 9500 - 050 - A	RV 9500 - 050 - B	50	1.97	178	7.01	128	5.04			14967	33648	18156	40815	1010	61.63	11,49	25.33	✓
RV 9500 - 063 - A	RV 9500 - 063 - B	63	2.48	204	8.03	141	5.55			15341	34487	18759	42173	1218	74.33	12,30	27.12	✓
RV 9500 - 075 - A	RV 9500 - 075 - B	75	2.95	228	8.98	153	6.02			15597	35063	19177	43111	1411	86.10	13,05	28.77	✓
RV 9500 - 080 - A	RV 9500 - 080 - B	80	3.15	238	9.37	158	6.22			15686	35264	19322	43439	1491	90.99	13,37	29.48	✓
RV 9500 - 100 - A	RV 9500 - 100 - B	100	3.94	278	10.94	178	7.01			15970	35901	19788	44485	1811	110.51	14,61	32.21	✓
RV 9500 - 125 - A	RV 9500 - 125 - B	125	4.92	328	12.91	203	7.99			16216	36455	20194	45398	2212	134.98	16,18	35.67	✓

◆ Disposable

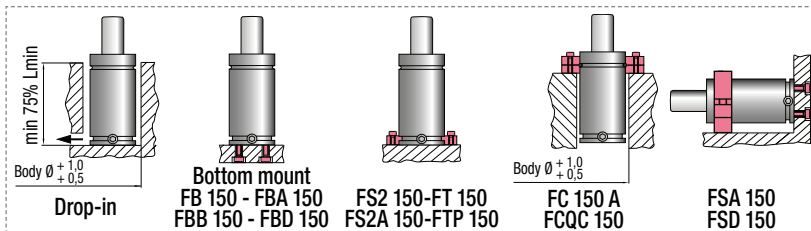

HOW TO ORDER

p. 57

INSTALLATION GUIDELINE

p. 205