

ISO 11901 - 3	VDI 3003 - Blatt 3	B2 4005 (BMW)	075.90.60 (FCA)
W-DX35-6204 (Ford)	B8 3180 220 000 004(MB)	39D 997 (VW)	



OSAS + OSM = OVER STROKE ACTIVE SAFETY + OVER STROKE MARKER

ACTIVE SAFETY

Il nuovo codice sarà fornito solo ad esaurimento del vecchio

The new code will be supplied only when the old will be out of stock

Der neue Kode wird nur angegeben, wenn der alte nicht mehr lieferbar ist

Le nouveau code sera fourni uniquement lorsque le vieux stock sera écoulé

El nuevo código será suministrado sólo cuando se agoten las existencias del antiguo

O novo código irá ser fornecido apenas quando o antigo esgotar stock



OSAS



USAS



OPAS

easu MANIPOLO p. 247

* F_{1i} = Isothermal end force at 100% Cu p. 16

** F_{1p} = Polytropic end force at 100% Cu

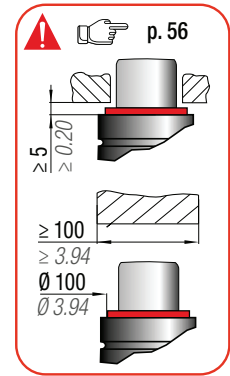
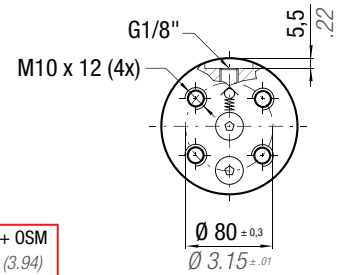
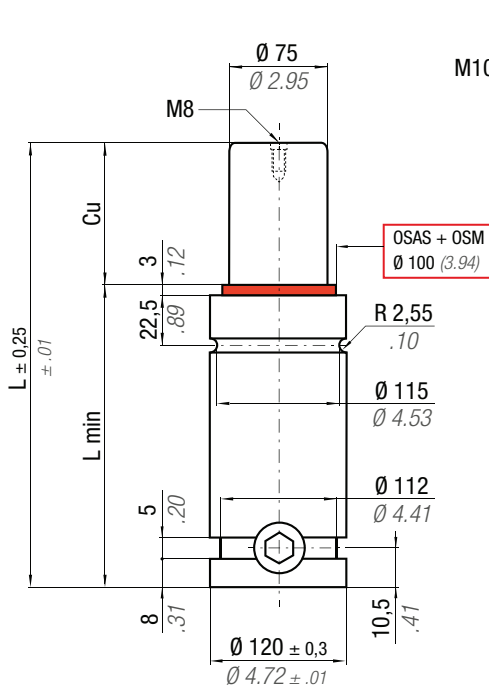

N ₂	0 - 80 °C 32 - 176 °F	ΔP ± 0,33 %/°C	P max 150 bar 2175 psi	P min 20 bar 290 psi	S 44,18 cm ² 6.848 in ²	SPM ~ 20 - 100 (at 20°C)	Max Speed 1,8 m/s	Maintenance kit 39BMRV06600C
----------------	--------------------------	---------------------------	------------------------------	----------------------------	---	--------------------------------	----------------------	---------------------------------

CODE PHASING OUT from 04/2021	NEW	Cu		L		L min		F ₀		F _{1i} *		F _{1p} **		V ₀		~Kg	~lb	PED 2014/68/EU
		mm	inch	mm	inch	mm	inch	daN	lb	daN	lb	daN	lb	cm ³	in ³			
RV 6600 - 016 - A	♦ RV 6600 - 016 - B	16	0.63	100	3.94	84	3.31	6630 ± 5%	14904	9141	20550	10631	23900	298	18.19	5,12	11.29	✓
RV 6600 - 019 - A	♦ RV 6600 - 019 - B	19	0.75	106	4.17	87	3.43			9393	21115	11022	24777	330	20.14	5,23	11.53	✓
RV 6600 - 025 - A	RV 6600 - 025 - B	25	0.98	118	4.65	93	3.66			9799	22028	11658	26209	394	24.04	5,47	12.06	✓
RV 6600 - 032 - A	RV 6600 - 032 - B	32	1.26	132	5.20	100	3.94			10157	22834	12228	27490	469	28.62	5,75	12.68	✓
RV 6600 - 038 - A	RV 6600 - 038 - B	38	1.50	144	5.67	106	4.17			10397	23374	12614	28357	533	32.53	5,99	13.21	✓
RV 6600 - 050 - A	RV 6600 - 050 - B	50	1.97	168	6.61	118	4.65			10757	24183	13196	29666	661	40.34	6,47	14.26	✓
RV 6600 - 063 - A	RV 6600 - 063 - B	63	2.48	194	7.64	131	5.16			11031	24799	13645	30675	799	48.76	6,99	15.41	✓
RV 6600 - 075 - A	RV 6600 - 075 - B	75	2.95	218	8.58	143	5.63			11219	25221	13954	31369	927	56.57	7,47	16.47	✓
RV 6600 - 080 - A	RV 6600 - 080 - B	80	3.15	228	8.98	148	5.83			11284	25367	14061	31611	980	59.80	7,67	16.91	✓
RV 6600 - 100 - A	RV 6600 - 100 - B	100	3.94	268	10.55	168	6.61			11490	25832	14404	32381	1193	72.80	8,46	18.65	✓
RV 6600 - 125 - A	RV 6600 - 125 - B	125	4.92	318	12.52	193	7.60	11669	26234	14703	33053	1459	89.03	9,46	20.86	✓		

♦ Disposable

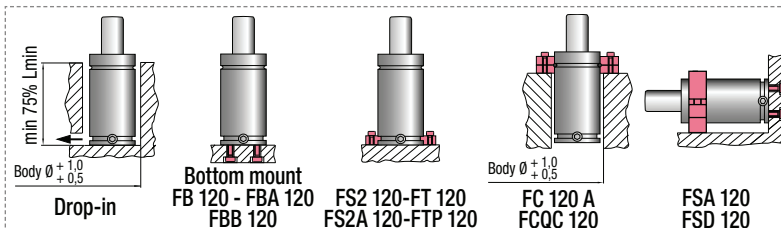

HOW TO ORDER

p. 57

INSTALLATION GUIDELINE

p. 205