



OSAS + OSM = **OVER STROKE ACTIVE SAFETY** + **OVER STROKE MARKER**

ACTIVE SAFETY

Il nuovo codice sarà fornito solo ad esaurimento del vecchio

The new code will be supplied only when the old will be out of stock

Der neue Kode wird nur angegeben, wenn der alte nicht mehr lieferbar ist

Le nouveau code sera fourni uniquement lorsque le vieux stock sera écolé

El nuevo código será suministrado sólo cuando se agoten las existencias del antiguo

O novo código irá ser fornecido apenas quando o antigo esgotar stock



OSAS



USAS



OPAS

* F_{1i} =

Isothermal end force at 100% Cu p. 16

** F_{1p} =

Polytropic end force at 100% Cu

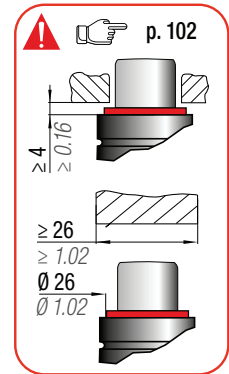
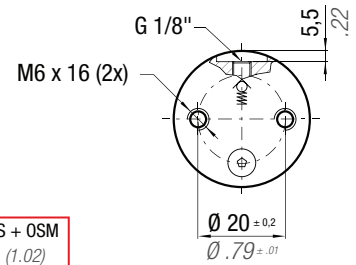
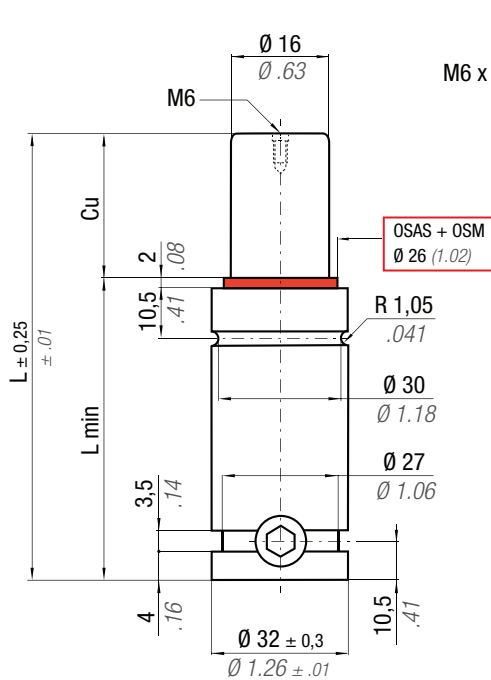

N ₂	0 - 80 °C 32 - 176 °F	ΔP ± 0,33 %/°C	P max 180 bar 2610 psi	P min 20 bar 290 psi	S 2,01 cm ² 0,312 in ²	SPM ~ 20 - 100 (at 20°C)	Max Speed 1,8 m/s	Maintenance kit 39BMRV00350C
----------------	--------------------------	---------------------------	------------------------------	----------------------------	--	--------------------------------	----------------------	---------------------------------

CODE PHASING OUT from 04/2021	NEW	Cu		L		L min		F ₀		F _{1i} *		F _{1p} **		V ₀		~Kg	~lb	PED 2014/68/EU
		mm	inch	mm	inch	mm	inch	daN	lb	daN	lb	daN	lb	cm ³	in ³			
RT 350 - 010 - A	♦ RT 350 - 010 - B	10	0.39	60	2.36	50	1.97	360 809 ± 5%	180 bar 2610psi	531	1194	607	1366	7,7	0,47	0,22	0,48	✓
RT 350 - 013 - A	♦ RT 350 - 013 - B	13	0.51	66	2.60	53	2.09			544	1224	627	1409	9,5	0,58	0,23	0,50	✓
RT 350 - 016 - A	RT 350 - 016 - B	16	0.63	72	2.83	56	2.20			554	1245	641	1440	11,2	0,68	0,24	0,52	✓
RT 350 - 019 - A	RT 350 - 019 - B	19	0.75	78	3.07	59	2.32			561	1261	651	1463	13,0	0,79	0,25	0,54	✓
RT 350 - 025 - A	RT 350 - 025 - B	25	0.98	90	3.54	65	2.56			571	1283	665	1496	16,6	1,01	0,27	0,60	✓
RT 350 - 032 - A	RT 350 - 032 - B	32	1.26	104	4.09	72	2.83			578	1300	676	1520	20,7	1,26	0,29	0,64	✓
RT 350 - 038 - A	RT 350 - 038 - B	38	1.50	116	4.57	78	3.07			583	1310	683	1535	24,3	1,48	0,31	0,68	✓
RT 350 - 050 - A	RT 350 - 050 - B	50	1.97	140	5.51	90	3.54			589	1323	691	1554	31,4	1,92	0,35	0,77	✓
RT 350 - 063 - A	RT 350 - 063 - B	63	2.48	166	6.54	103	4.06			593	1333	697	1568	39,1	2,39	0,39	0,86	✓
RT 350 - 075 - A	RT 350 - 075 - B	75	2.95	190	7.48	115	4.53			595	1338	701	1576	46,3	2,83	0,43	0,95	✓
RT 350 - 080 - A	RT 350 - 080 - B	80	3.15	200	7.87	120	4.72	596	1340	702	1579	49,2	3,00	0,45	0,99	✓		
RT 350 - 100 - A	RT 350 - 100 - B	100	3.94	240	9.45	140	5.51	599	1346	706	1588	61,1	3,73	0,51	1,12	✓		
RT 350 - 125 - A	RT 350 - 125 - B	125	4.92	290	11.42	165	6.50	606	1363	717	1613	74,9	4,57	0,59	1,30	✓		

♦ Disposable

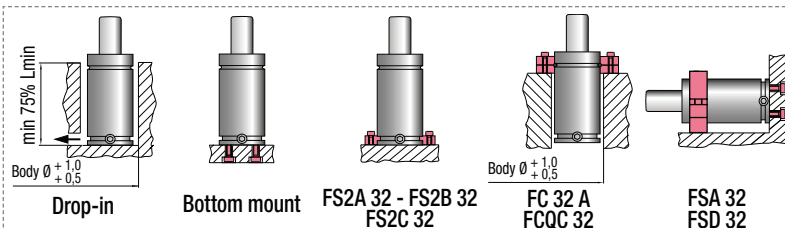

HOW TO ORDER
p. 103

INSTALLATION GUIDELINE
p. 205