

K 32 R (Nissan)	E24.54.815.G (PSA)	EM24.54.700 (Renault)
SMS DNH 3203n Rev.3 (TOYOTA)		

RT 1000

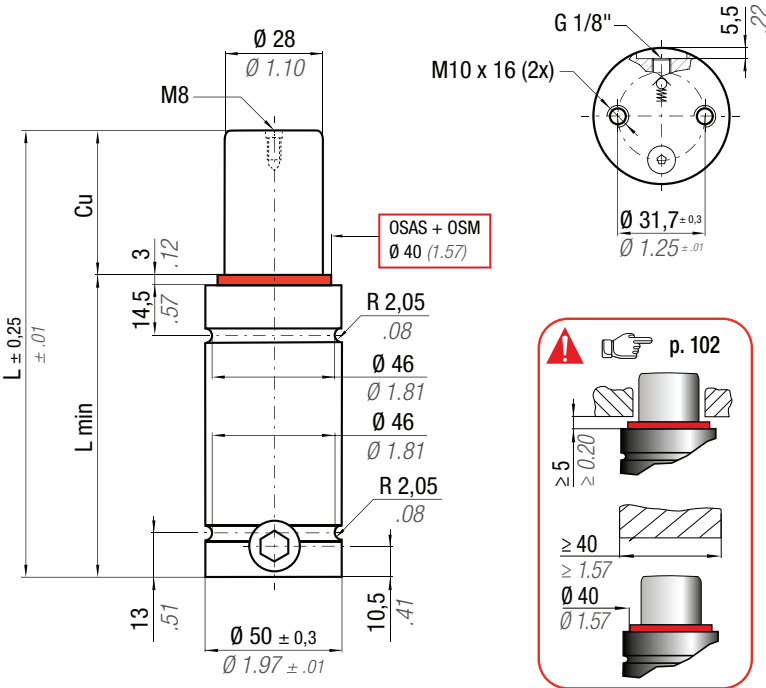

OSAS + OSM = OVER STROKE ACTIVE SAFETY + OVER STROKE MARKER



ACTIVE SAFETY



OSAS



USAS



OPAS

Il nuovo codice sarà fornito solo ad esaurimento del vecchio

The new code will be supplied only when the old will be out of stock

Der neue Kode wird nur angegeben, wenn der alte nicht mehr lieferbar ist

Le nouveau code sera fourni uniquement lorsque le vieux stock sera écoulé

El nuevo código será suministrado sólo cuando se agoten las existencias del antiguo

O novo código irá ser fornecido apenas quando o antigo esgotar stock

* F_{1i} =

Isothermal end force at 100% Cu



p. 16

** F_{1p} =

Polytrophic end force at 100% Cu



N ₂		0 - 80 °C 32 - 176 °F	ΔP ± 0,33 %/°C	P max 150 bar 2175 psi	P min 20 bar 290 psi	S 6,15 cm ² 0.953 in ²	SPM ~ 20 - 100 (at 20°C)	Max Speed 1,8 m/s	Maintenance kit 39BMRV01000C
CODE	NEW	Cu	L	L min	F ₀	F _{1i} *	F _{1p} **	V ₀	
PHASING OUT from 04/2021		mm inch	mm inch	mm inch	Initial force daN lb	End force * daN lb	End force ** daN lb	cm ³ in ³	~Kg ~lb
RT 1000 - 010 - A	♦ RT 1000 - 010 - B	10 0.39	72 2.83	62 2.44	920 2068 ± 5%	1282 2883	1495 3329	25,5 1,56	0,68 1,50
RT 1000 - 013 - A	♦ RT 1000 - 013 - B	13 0.51	78 3.07	65 2.56		1332 2995	1572 3500	30,2 1,84	0,70 1,54
RT 1000 - 016 - A	RT 1000 - 016 - B	16 0.63	84 3.31	68 2.68		1371 3082	1633 3635	34,9 2,13	0,73 1,61
RT 1000 - 019 - A	RT 1000 - 019 - B	19 0.75	90 3.54	71 2.80		1402 3151	1682 3745	39,6 2,42	0,75 1,65
RT 1000 - 025 - A	RT 1000 - 025 - B	25 0.98	102 4.02	77 3.03		1448 3255	1756 3909	48,9 2,98	0,80 1,76
RT 1000 - 032 - A	RT 1000 - 032 - B	32 1.26	116 4.57	84 3.31		1486 3340	1817 4047	59,8 3,65	0,86 1,90
RT 1000 - 038 - A	RT 1000 - 038 - B	38 1.50	128 5.04	90 3.54		1510 3394	1856 4132	69,2 4,22	0,90 1,98
RT 1000 - 050 - A	RT 1000 - 050 - B	50 1.97	152 5.98	102 4.02		1543 3469	1911 4256	87,9 5,36	1,00 2,20
RT 1000 - 063 - A	RT 1000 - 063 - B	63 2.48	178 7.01	115 4.53		1567 3523	1951 4346	108,1 6,60	1,10 2,43
RT 1000 - 075 - A	RT 1000 - 075 - B	75 2.95	202 7.95	127 5.00		1583 3559	1977 4404	126,8 7,74	1,20 2,65
RT 1000 - 080 - A	RT 1000 - 080 - B	80 3.15	212 8.35	132 5.20	1588 3571	1986 4424	134,6 8,21	1,24 2,73	
RT 1000 - 100 - A	RT 1000 - 100 - B	100 3.94	252 9.92	152 5.98	1605 3608	2013 4485	165,8 10,12	1,40 3,09	
RT 1000 - 125 - A	RT 1000 - 125 - B	125 4.92	302 11.89	177 6.97	1619 3639	2036 4537	204,7 12,49	1,60 3,53	

♦ Disposable

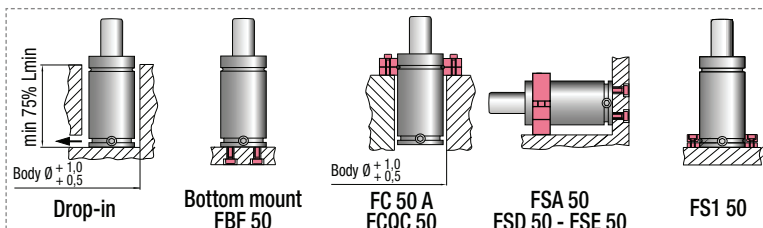

HOW TO ORDER

p. 101

INSTALLATION GUIDELINE

p. 205